

# Photometric Test Report



## ECLFRESNELCT+

350W indoor LED Fresnel  
with 6 color source, 200mm – 8" lens  
(High Brightness Mode)

## CONTENTS

Table of contents	2
Testing process	4
Color preset Full on	
Max Zoom	5
Med Zoom	8
Min Zoom	11
Color preset Red	
Max Zoom	14
Med Zoom	17
Min Zoom	20
Color preset Green	
Max Zoom	23
Med Zoom	26
Min Zoom	29
Color preset Blue	
Max Zoom	32
Med Zoom	35
Min Zoom	38
Color preset Cyan	
Max Zoom	41
Med Zoom	44
Min Zoom	47
Color preset Mint	
Max Zoom	50
Med Zoom	53
Min Zoom	56
Color preset Amber	
Max Zoom	59
Med Zoom	62
Min Zoom	65

#### Color temperature 2800K

Max Zoom 68

Med Zoom 73

Min Zoom 78

#### Color temperature 3200K

Max Zoom 83

Med Zoom 88

Min Zoom 93

#### Color temperature 4000K

Max Zoom 98

Med Zoom 103

Min Zoom 108

#### Color temperature 5600K

Max Zoom 113

Med Zoom 118

Min Zoom 123

#### Color temperature 6000K

Max Zoom 128

Med Zoom 133

Min Zoom 138

## TESTING PROCESS

Prolights has its own optical testing laboratory in order to provide accurate photometric reports for its lighting products. The testing laboratory contains certain variety of precise lighting measurement systems that ensure an optimal reading of all the characteristic parameters of the lighting devices. All measurements are made at a controlled room temperature of 20°C without any external light sources. This photometric report is obtained through the data measured by a high precision measurement system and analyzed by a dedicate software.

### Prolights measurement instrument

Prolights measurement instrument is a complete measurement system for any light source. It's equipped with two-axis goniometer, that enables to measure the full 3D distribution field of the light source. This instrument measures the light intensity, the beam angle and the most significative colors parameters, like color temperature, spectral distribution, CRI, CQS, TM-30 with a very high accuracy rate.

**Please Note:** All measurements are made with light source at operating temperature. Before starting the measurement, the instrument analyzes the process of the light source during the heating phase. The measuring process of all the parameters begins only when the light emission is stable, that is with a variation of less than 0.5% in a 15 minutes time frame.

### Prolights measurement software

The software provides user friendly interface for the operator who does the measurements, and it also analyzes and processes all the collected data by the instrument. With this software it is possible to see the measured data in real-time and it is possible to examine all the measured data and graphics afterwards as well. All information is collected in a specific Prolights template, and the software creates also IES and LDT files, which are widely used to transfer the photometric data, and to develop lighting system.

Additionally, the fixtures are rechecked using various hand-held instruments like Sekonic C-700 and Gossen Mavospec Base, this is done to ensure, that the data in the photometric report are as accurate as possible.



Total lumen output:

9988 lm

Peak candela output:

11490 cd

PRODUCT NAME:

ECLFRCTPM

MEASURAMENT CONDITIONS:

Beam angle:

Max Zoom

Target:

Full On - HB

Operator:

Salvatore Giglio

Date and time:

18/09/2023 13:34:36

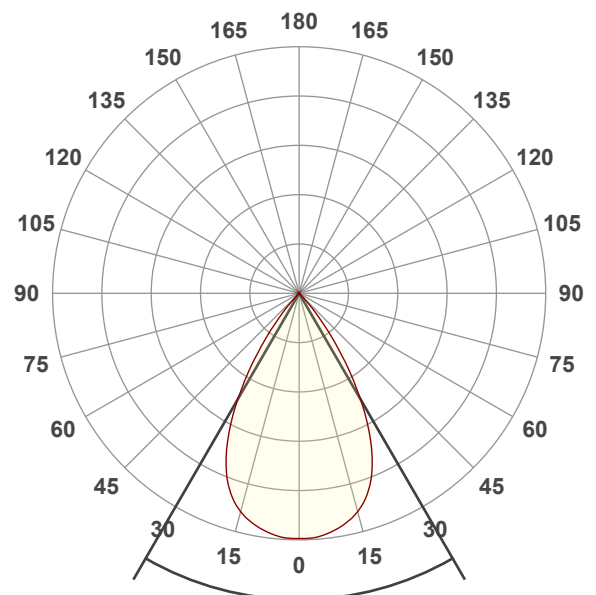

Beam angle 50%: 60,1°

Field angle 10%: 80,8°

Cut off angle 2.5%: 88,4°

Spectra

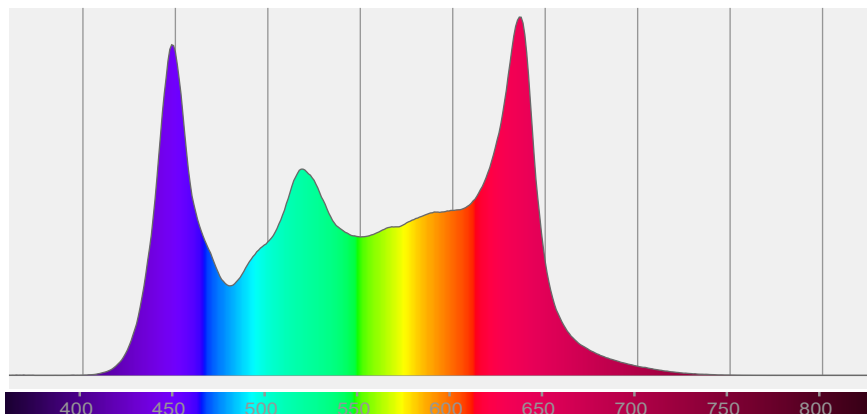

# BEAM DETAILS



Beam angle 50%	Field angle 10%	Cut off angle 2,5%	Intensity ratio in 120° cone	Intensity ratio in 90° cone
60,1°	80,8°	88,4°	100,0%	99,7%

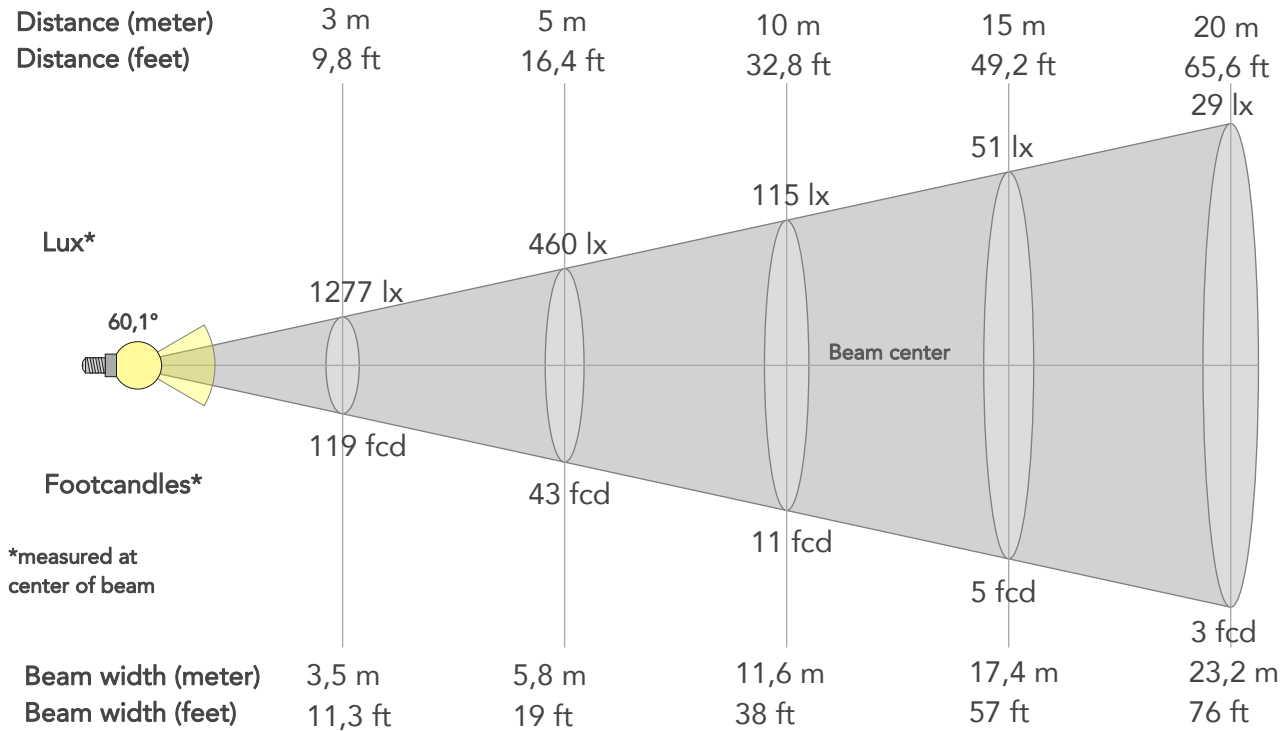

## BEAM INTENSITIES AND WIDTHS

Distance	1m	2m	3m	4m	5m	7,5m	10m	15m	20m	25m	30m	40m	50m
Distance	3,3ft	6,6ft	9,8ft	13,1ft	16,4ft	24,6ft	32,8ft	49,2ft	65,6ft	82ft	98,4ft	131,2ft	164ft
Lux	11490lx	2872lx	1277lx	718lx	460lx	204lx	115lx	51lx	29lx	18lx	13lx	7lx	5lx
Footcand.	1067fcd	267fcd	119fcd	67fcd	43fcd	19fcd	11fcd	5fcd	3fcd	2fcd	1fcd	1fcd	0fcd
Beam wid.	1,2m	2,3m	3,5m	4,6m	5,8m	8,7m	11,6m	17,4m	23,2m	28,9m	34,7m	46,3m	57,9m
Beam wid.	3,8ft	7,6ft	11,3ft	15,2ft	19ft	28,5ft	38ft	57ft	76ft	95ft	113,9ft	151,9ft	189,9ft

## LINEAR DISTRIBUTION DIAGRAM

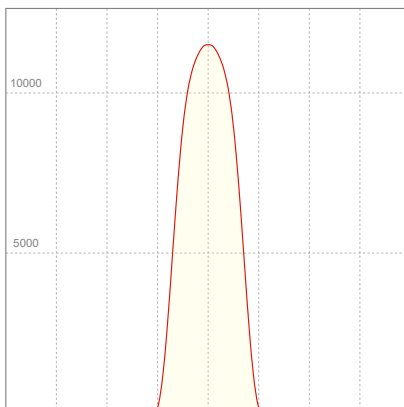

## ELECTRICAL SPECIFICATIONS

Input voltage	Input current	Input power	Effeciency
226V	1,55A	343,8W	29lm/W

Power FC
0,99

## ISO CANDELA DIAGRAM

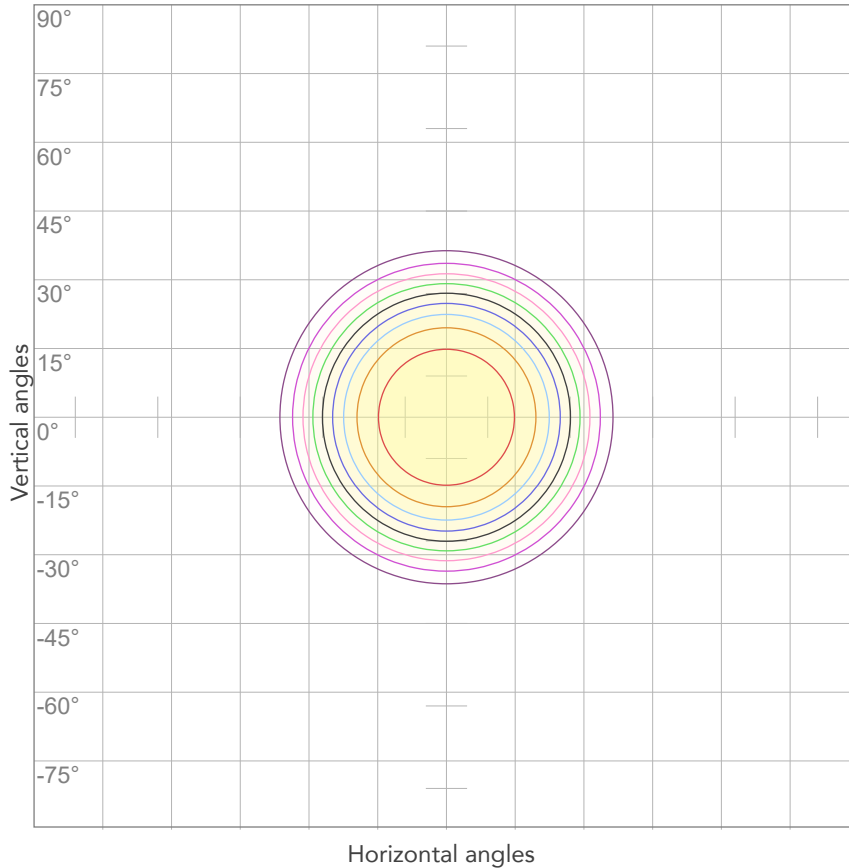

10%	1149 cd
20%	2298 cd
30%	3447 cd
40%	4596 cd
50%	5745 cd
60%	6894 cd
70%	8043 cd
80%	9192 cd

Conditions:

Number of c-planes: 2

Candela at center: 11490 cd

## ISO LUX DIAGRAM

MH: 10,0 m

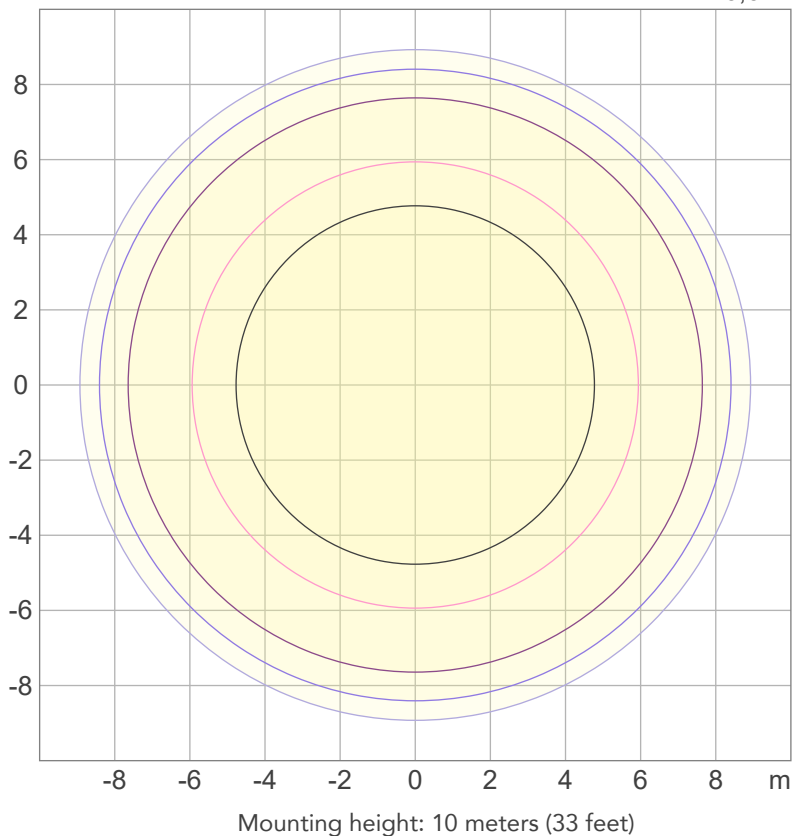

3%	3,45 lx
5%	5,74 lx
10%	11,5 lx
30%	34,5 lx
50%	57,4 lx

Conditions:

Number of c-planes: 2

Lux at center: 115 lx

*Lux distribution on a surface when lamp is mounted at 10 meters from the surface.*



Total lumen output:

7633 lm

Peak candela output:

38845 cd

**PRODUCT NAME:**

ECLFRCTPM

**MEASURAMENT CONDITIONS:**

Beam angle:

Med Zoom

Target:

Full On - HB

Operator:

Salvatore Giglio

Date and time:

18/09/2023 12:49:33

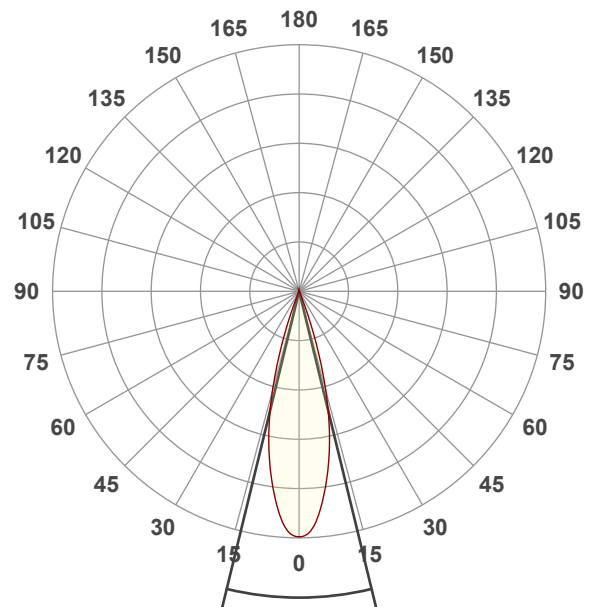

Beam angle 50%: 27,4°

Field angle 10%: 40,7°

Cut off angle 2.5%: 45,5°

Spectra

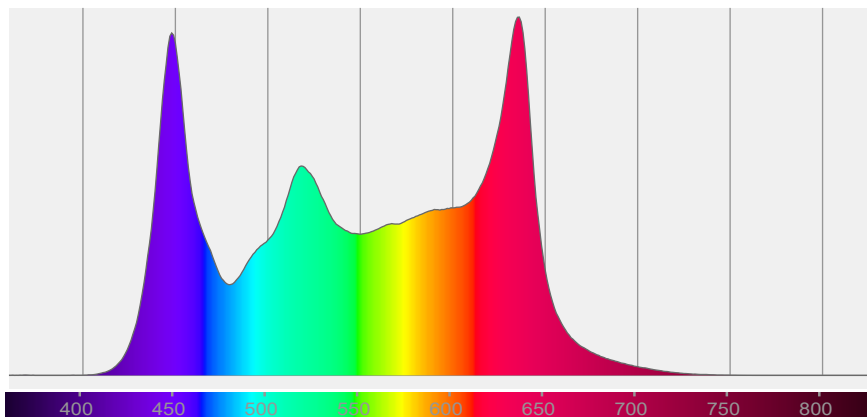



# BEAM DETAILS



Beam angle 50%	Field angle 10%	Cut off angle 2,5%	Intensity ratio in 120° cone	Intensity ratio in 90° cone
27,4°	40,7°	45,5°	100,0%	100,0%

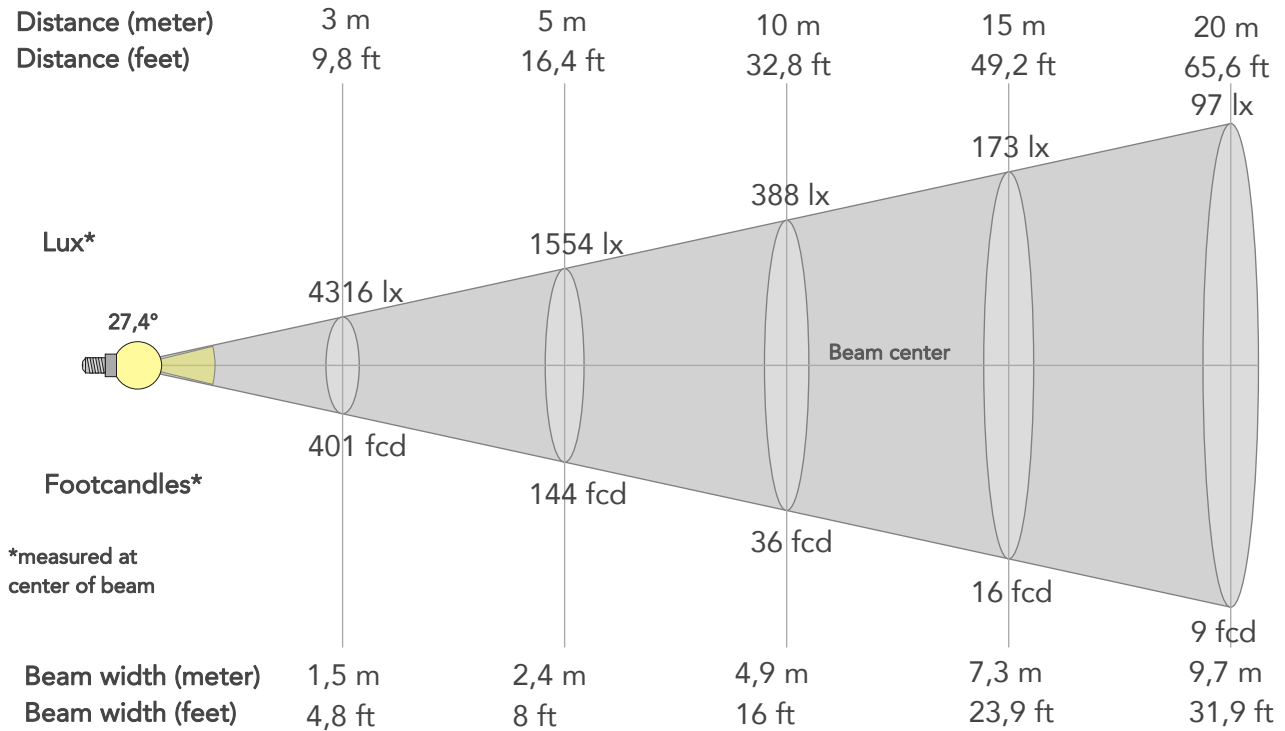

## BEAM INTENSITIES AND WIDTHS

Distance	1m	2m	3m	4m	5m	7,5m	10m	15m	20m	25m	30m	40m	50m
Distance	3,3ft	6,6ft	9,8ft	13,1ft	16,4ft	24,6ft	32,8ft	49,2ft	65,6ft	82ft	98,4ft	131,2ft	164ft
Lux	38845lx	9711lx	4316lx	2428lx	1554lx	691lx	388lx	173lx	97lx	62lx	43lx	24lx	16lx
Footcand.	3609fcd	902fcd	401fcd	226fcd	144fcd	64fcd	36fcd	16fcd	9fcd	6fcd	4fcd	2fcd	1fcd
Beam wid.	0,5m	1m	1,5m	1,9m	2,4m	3,7m	4,9m	7,3m	9,7m	12,2m	14,6m	19,5m	24,3m
Beam wid.	1,6ft	3,2ft	4,8ft	6,4ft	8ft	12ft	16ft	23,9ft	31,9ft	39,9ft	47,9ft	63,9ft	79,8ft

## LINEAR DISTRIBUTION DIAGRAM

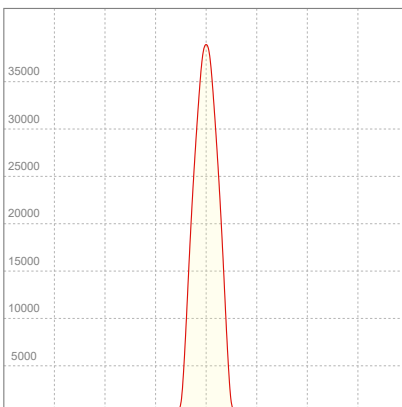

## ELECTRICAL SPECIFICATIONS

Input voltage	Input current	Input power	Effeciency
226V	1,52A	339,3W	22lm/W

Power FC
0,99

## ISO CANDELA DIAGRAM

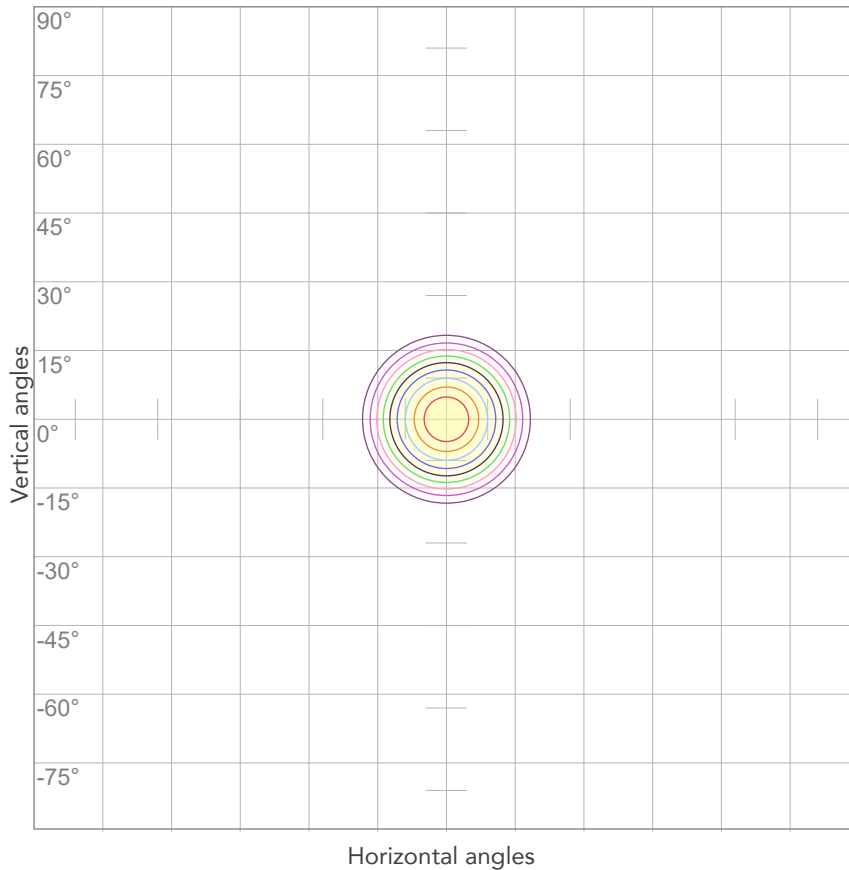

10%	3885 cd
20%	7769 cd
30%	11654 cd
40%	15538 cd
50%	19423 cd
60%	23307 cd
70%	27192 cd
80%	31076 cd

Conditions:

Number of c-planes: 2

Candela at center: 38845 cd

## ISO LUX DIAGRAM

MH: 10,0 m

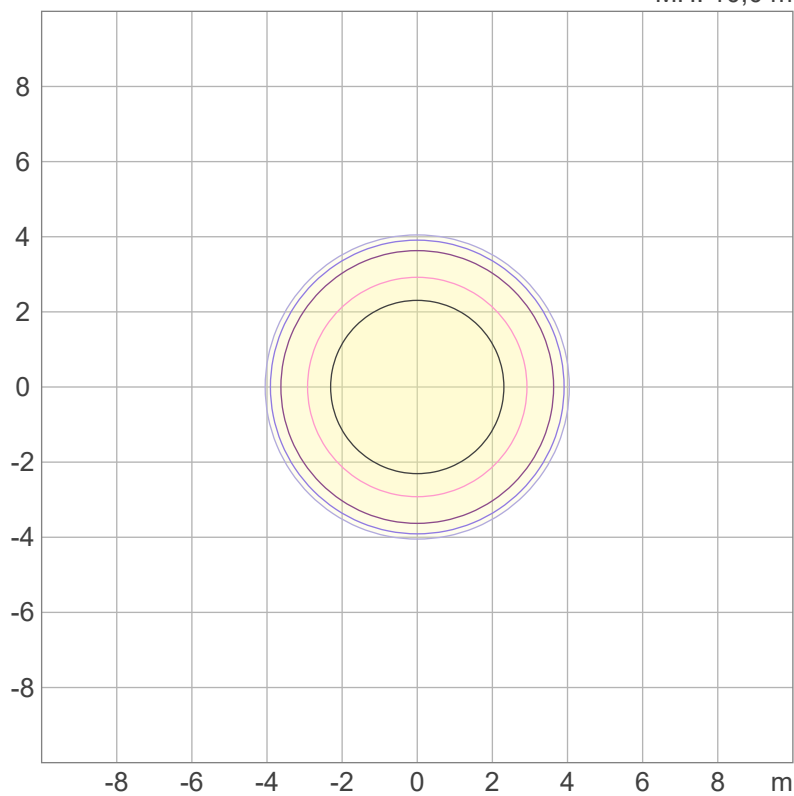

Mounting height: 10 meters (33 feet)

3%	11,7 lx
5%	19,4 lx
10%	38,8 lx
30%	117 lx
50%	194 lx

Conditions:

Number of c-planes: 2

Lux at center: 388 lx

*Lux distribution on a surface when lamp is mounted at 10 meters from the surface.*



Total lumen output:

4073 lm

Peak candela output:

147707 cd

PRODUCT NAME:

ECLFRCTPM

MEASUREMENT CONDITIONS:

Beam angle:

Min Zoom

Target:

Full On - HB

Operator:

Salvatore Giglio

Date and time:

18/09/2023 12:19:28

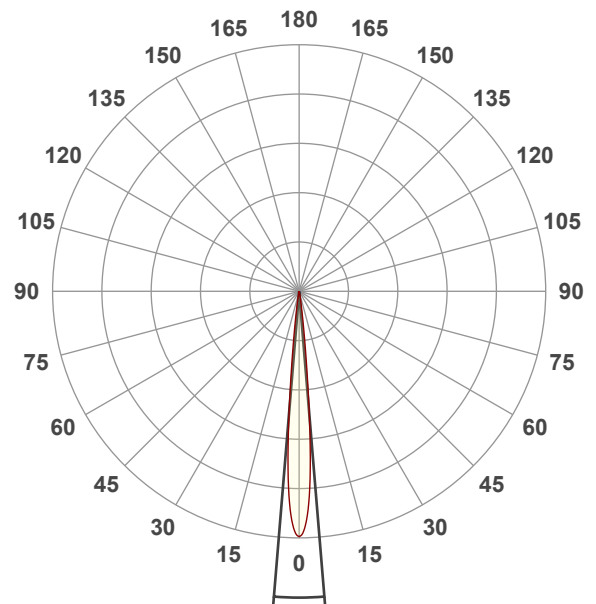

Beam angle 50%: 9,4°

Field angle 10%: 15,3°

Cut off angle 2.5%: 20°

Spectra

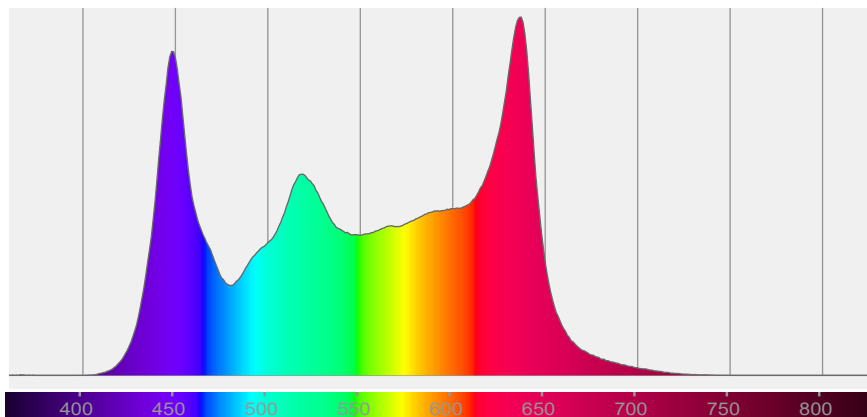

# BEAM DETAILS



Beam angle 50%	Field angle 10%	Cut off angle 2,5%	Intensity ratio in 120° cone	Intensity ratio in 90° cone
9,4°	15,3°	20°	100,0%	100,0%

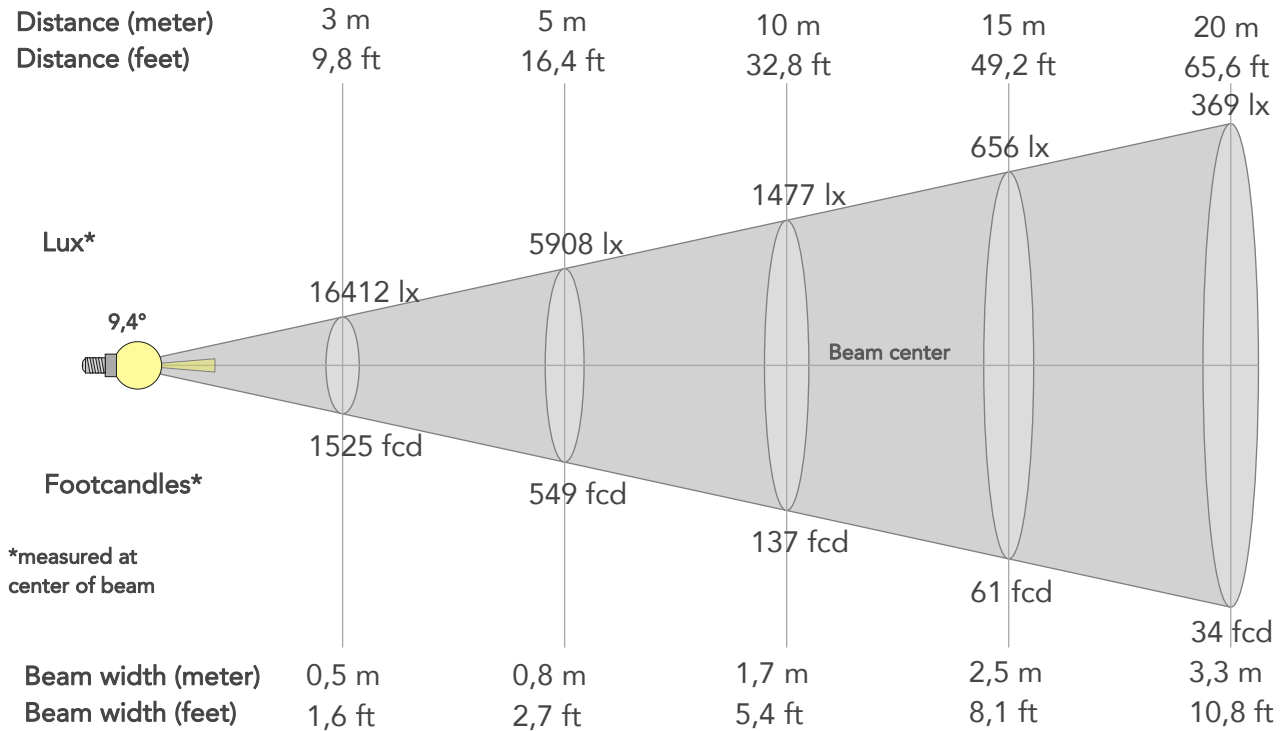

## BEAM INTENSITIES AND WIDTHS

Distance	1m	2m	3m	4m	5m	7,5m	10m	15m	20m	25m	30m	40m	50m
Distance	3,3ft	6,6ft	9,8ft	13,1ft	16,4ft	24,6ft	32,8ft	49,2ft	65,6ft	82ft	98,4ft	131,2ft	164ft
Lux	147707lx	36927lx	16412lx	9232lx	5908lx	2626lx	1477lx	656lx	369lx	236lx	164lx	92lx	59lx
Footcand.	13722fcd	3431fcd	1525fcd	858fcd	549fcd	244fcd	137fcd	61fcd	34fcd	22fcd	15fcd	9fcd	5fcd
Beam wid.	0,2m	0,3m	0,5m	0,7m	0,8m	1,2m	1,7m	2,5m	3,3m	4,1m	5m	6,6m	8,3m
Beam wid.	0,5ft	1,1ft	1,6ft	2,2ft	2,7ft	4,1ft	5,4ft	8,1ft	10,8ft	13,6ft	16,3ft	21,7ft	27,1ft

## LINEAR DISTRIBUTION DIAGRAM

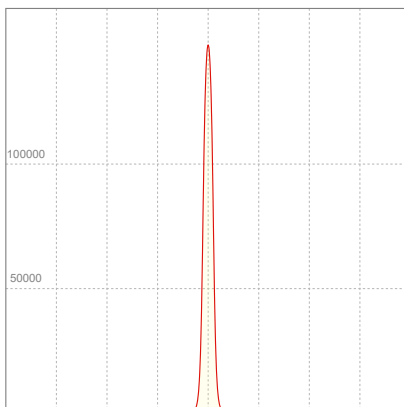

## ELECTRICAL SPECIFICATIONS

Input voltage	Input current	Input power	Effeciency
226V	1,56A	348,8W	12lm/W

Power FC
0,99

## ISO CANDELA DIAGRAM

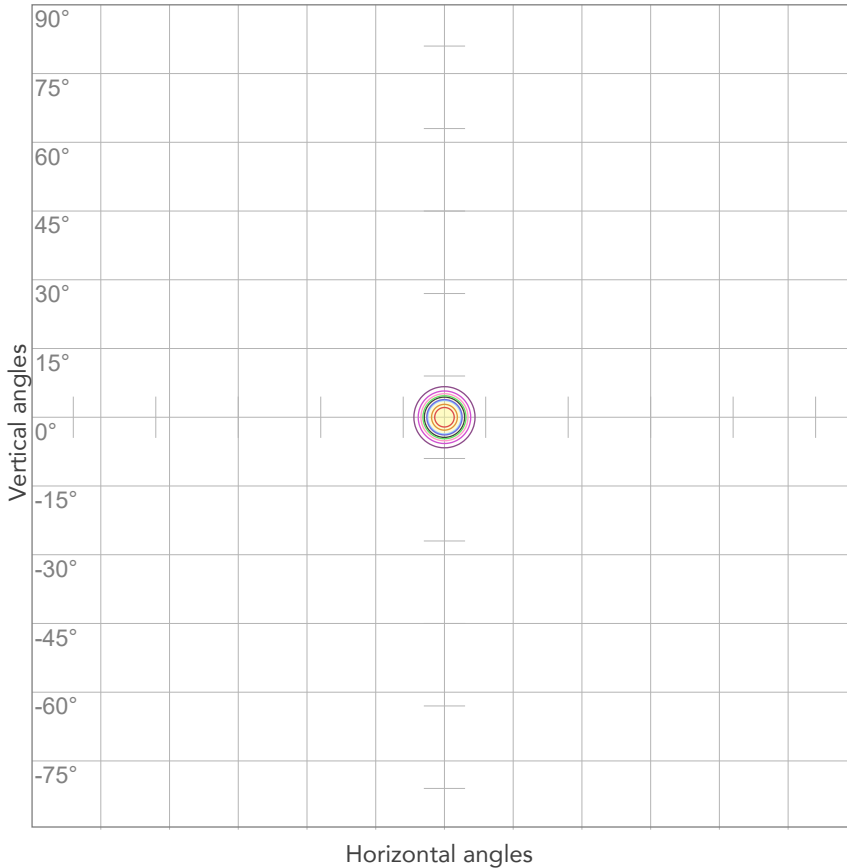

10%	14771 cd
20%	29541 cd
30%	44312 cd
40%	59083 cd
50%	73853 cd
60%	88624 cd
70%	103395 cd
80%	118165 cd

Conditions:

Number of c-planes: 2

Candela at center: 147707 cd

## ISO LUX DIAGRAM

MH: 10,0 m

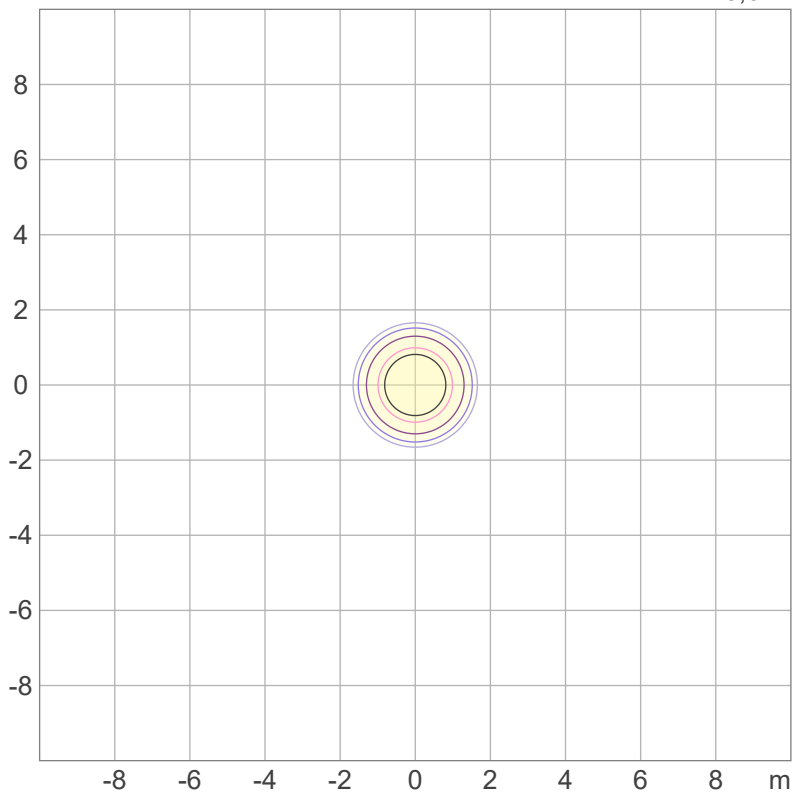

3%	44,3 lx
5%	73,9 lx
10%	148 lx
30%	443 lx
50%	739 lx

Conditions:

Number of c-planes: 2

Lux at center: 1477 lx

*Lux distribution on a surface when lamp is mounted at 10 meters from the surface.*



Total lumen output:

1047 lm

Peak candela output:

1211 cd

PRODUCT NAME:

ECLFRCTPM

MEASURAMENT CONDITIONS:

Beam angle:

Max Zoom

Target:

Red - HB

Operator:

Salvatore Giglio

Date and time:

03/10/2023 10:47:48

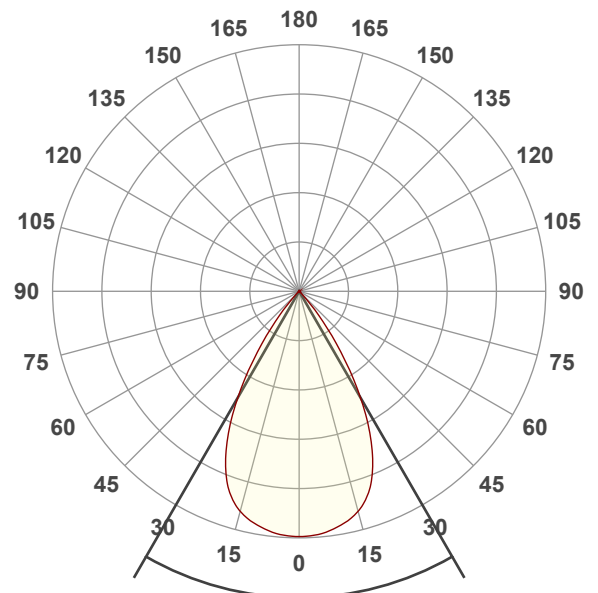

Beam angle 50%: 60°

Field angle 10%: 80,6°

Cut off angle 2.5%: 88,4°

Spectra

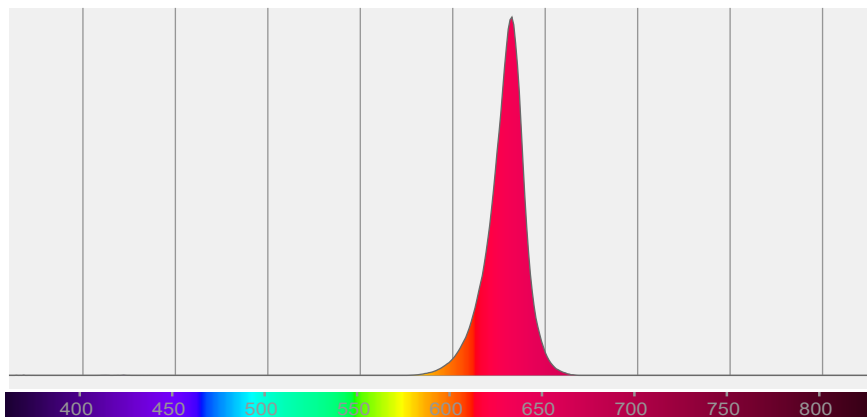

# BEAM DETAILS



Beam angle 50%	Field angle 10%	Cut off angle 2,5%	Intensity ratio in 120° cone	Intensity ratio in 90° cone
60°	80,6°	88,4°	100,0%	99,8%

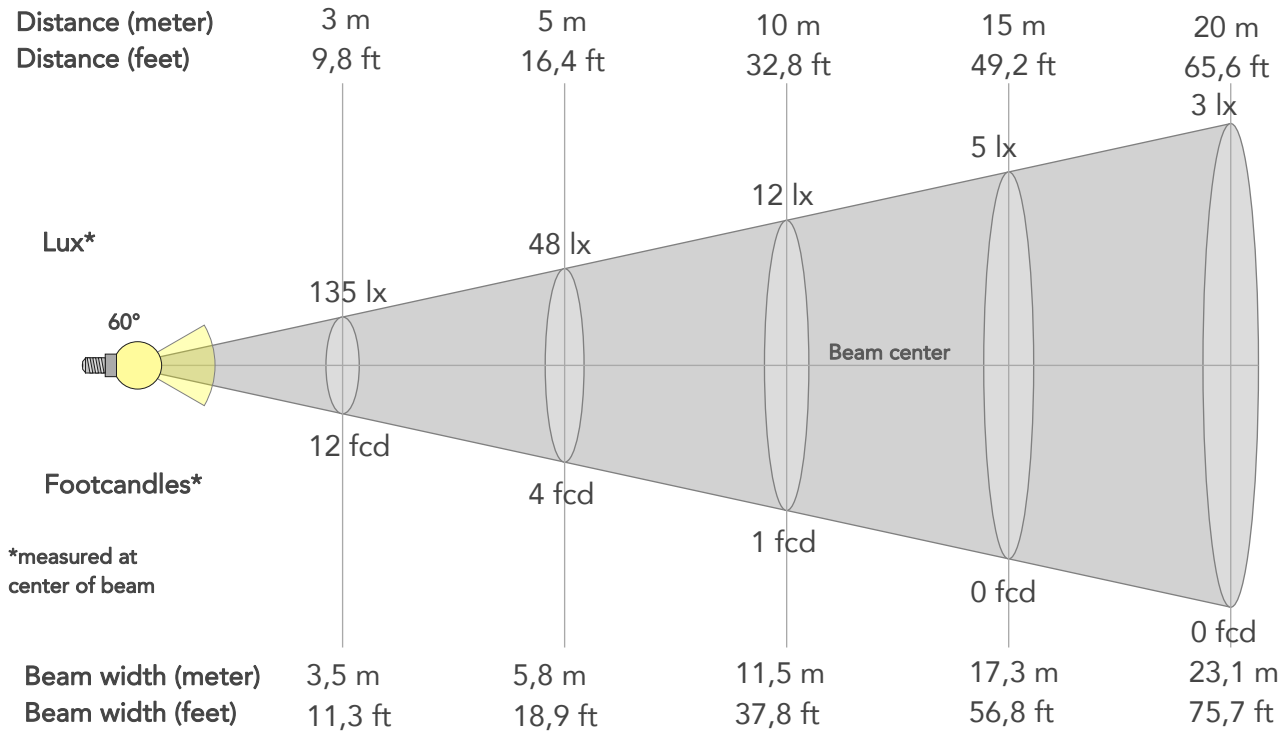

## BEAM INTENSITIES AND WIDTHS

Distance	1m	2m	3m	4m	5m	7,5m	10m	15m	20m	25m	30m	40m	50m
Distance	3,3ft	6,6ft	9,8ft	13,1ft	16,4ft	24,6ft	32,8ft	49,2ft	65,6ft	82ft	98,4ft	131,2ft	164ft
Lux	1211lx	303lx	135lx	76lx	48lx	22lx	12lx	5lx	3lx	2lx	1lx	1lx	0lx
Footcand.	112fcd	28fcd	12fcd	7fcd	4fcd	2fcd	1fcd	0fcd	0fcd	0fcd	0fcd	0fcd	0fcd
Beam wid.	1,2m	2,3m	3,5m	4,6m	5,8m	8,7m	11,5m	17,3m	23,1m	28,8m	34,6m	46,1m	57,7m
Beam wid.	3,8ft	7,6ft	11,3ft	15,1ft	18,9ft	28,4ft	37,8ft	56,8ft	75,7ft	94,6ft	113,5ft	151,4ft	189,2ft

## LINEAR DISTRIBUTION DIAGRAM

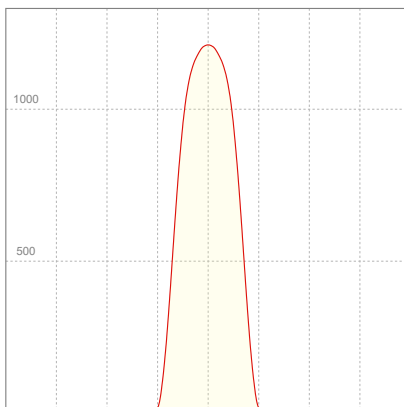

## ELECTRICAL SPECIFICATIONS

Input voltage	Input current	Input power	Effeciency
229V	0,345A	51,1W	20lm/W

Power FC
0,65

## ISO CANDELA DIAGRAM

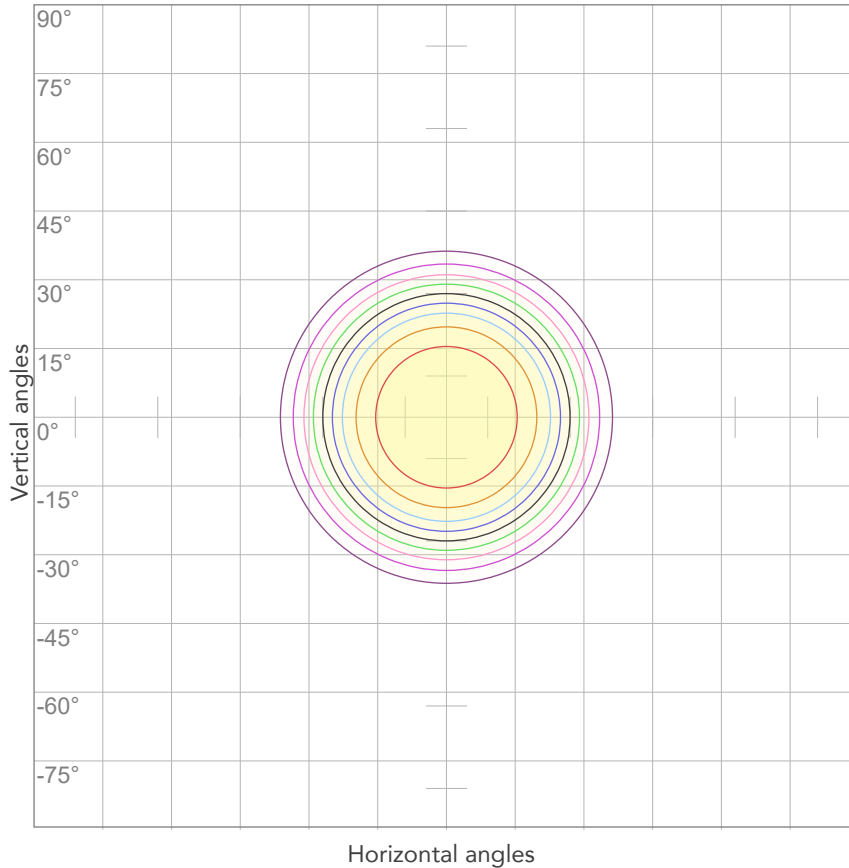

10%	121 cd
20%	242 cd
30%	363 cd
40%	484 cd
50%	605 cd
60%	726 cd
70%	847 cd
80%	968 cd

Conditions:

Number of c-planes: 2

Candela at center: 1211 cd

## ISO LUX DIAGRAM

MH: 10,0 m

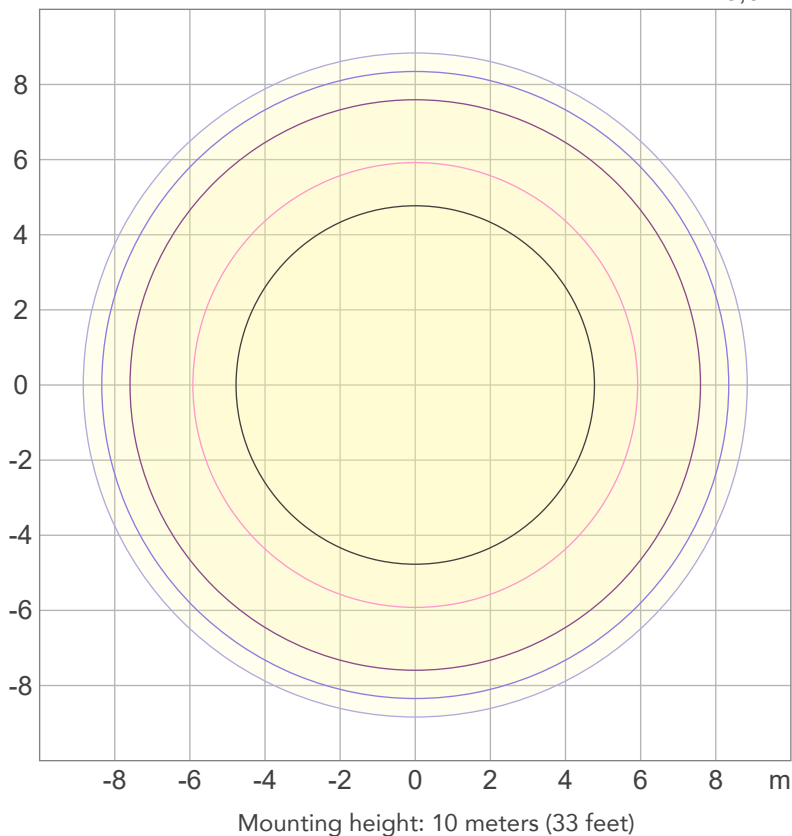

3%	0,363 lx
5%	0,605 lx
10%	1,21 lx
30%	3,63 lx
50%	6,05 lx

Conditions:

Number of c-planes: 2

Lux at center: 12,1 lx

*Lux distribution on a surface when lamp is mounted at 10 meters from the surface.*





Total lumen output:

812 lm

Peak candela output:

4205 cd

PRODUCT NAME:

ECLFRCTPM

MEASURAMENT CONDITIONS:

Beam angle:

Med Zoom

Target:

Red - HB

Operator:

Salvatore Giglio

Date and time:

03/10/2023 12:08:10

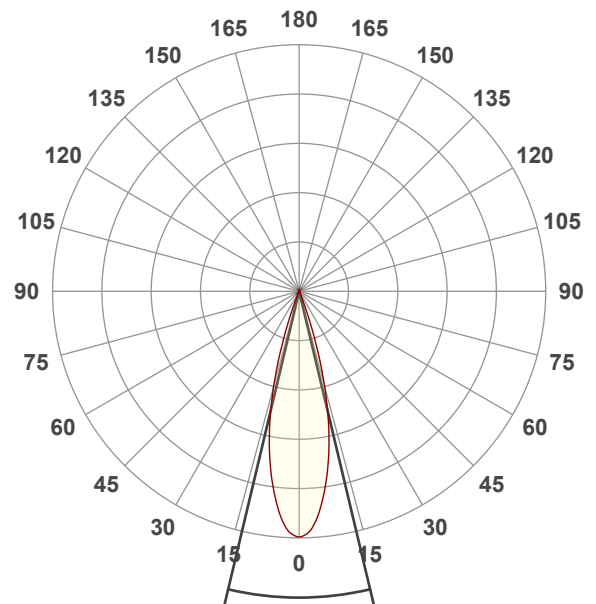

Beam angle 50%: 26,8°

Field angle 10%: 40,4°

Cut off angle 2.5%: 45,3°

Spectra

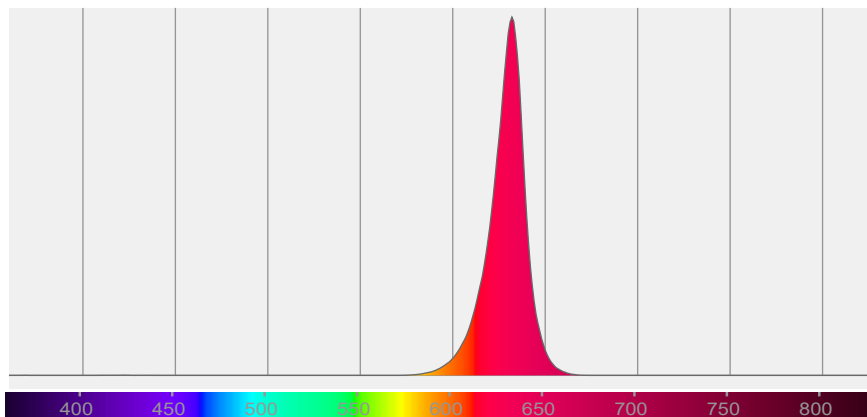

# BEAM DETAILS



Beam angle 50%	Field angle 10%	Cut off angle 2,5%	Intensity ratio in 120° cone	Intensity ratio in 90° cone
26,8°	40,4°	45,3°	100,0%	99,9%

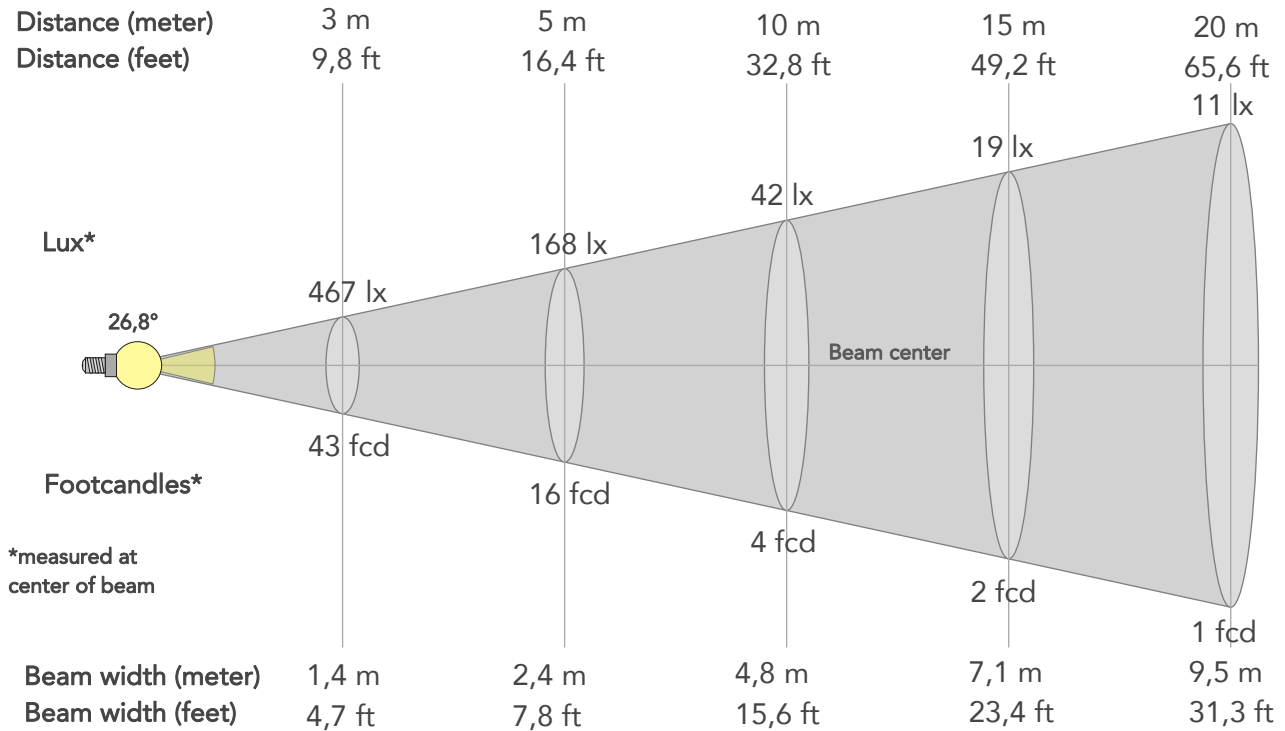

## BEAM INTENSITIES AND WIDTHS

Distance	1m	2m	3m	4m	5m	7,5m	10m	15m	20m	25m	30m	40m	50m
Distance	3,3ft	6,6ft	9,8ft	13,1ft	16,4ft	24,6ft	32,8ft	49,2ft	65,6ft	82ft	98,4ft	131,2ft	164ft
Lux	4205lx	1051lx	467lx	263lx	168lx	75lx	42lx	19lx	11lx	7lx	5lx	3lx	2lx
Footcand.	391fcd	98fcd	43fcd	24fcd	16fcd	7fcd	4fcd	2fcd	1fcd	1fcd	0fcd	0fcd	0fcd
Beam wid.	0,5m	1m	1,4m	1,9m	2,4m	3,6m	4,8m	7,1m	9,5m	11,9m	14,3m	19,1m	23,8m
Beam wid.	1,6ft	3,1ft	4,7ft	6,2ft	7,8ft	11,7ft	15,6ft	23,4ft	31,3ft	39,1ft	46,9ft	62,5ft	78,1ft

## LINEAR DISTRIBUTION DIAGRAM

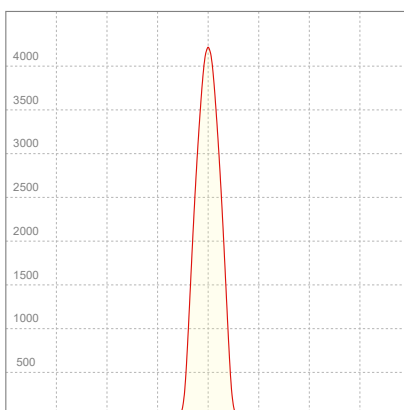

## ELECTRICAL SPECIFICATIONS

Input voltage	Input current	Input power	Effeciency
229V	0,349A	53,1W	15lm/W

Power FC
0,66

## ISO CANDELA DIAGRAM

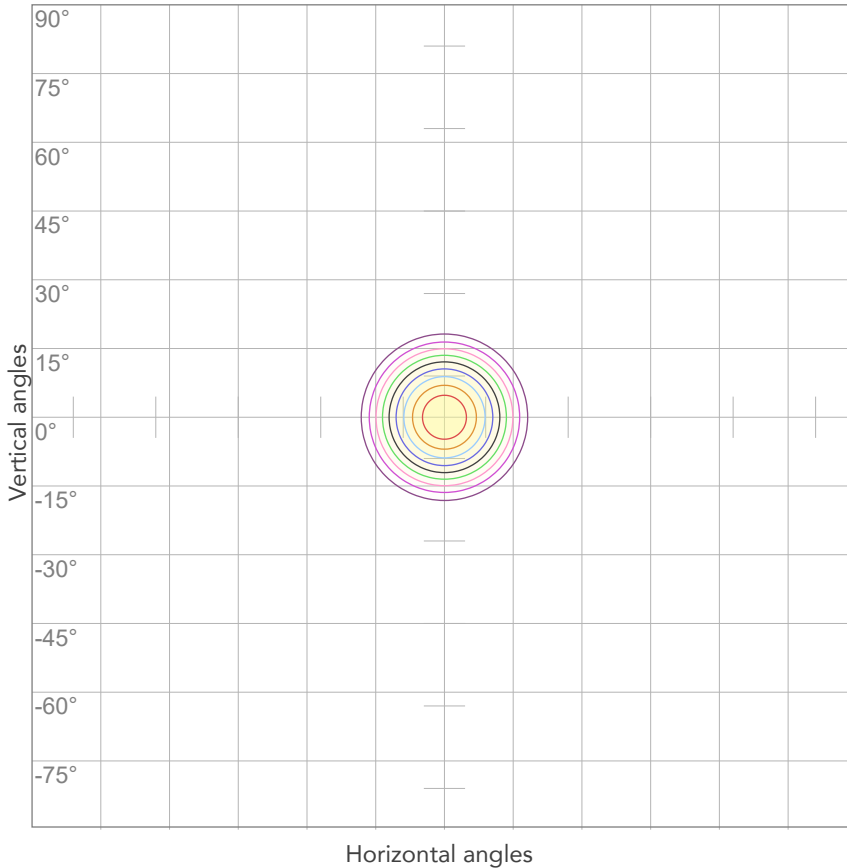

10%	420 cd
20%	841 cd
30%	1261 cd
40%	1682 cd
50%	2102 cd
60%	2523 cd
70%	2943 cd
80%	3364 cd

Conditions:

Number of c-planes: 2

Candela at center: 4205 cd

## ISO LUX DIAGRAM

MH: 10,0 m

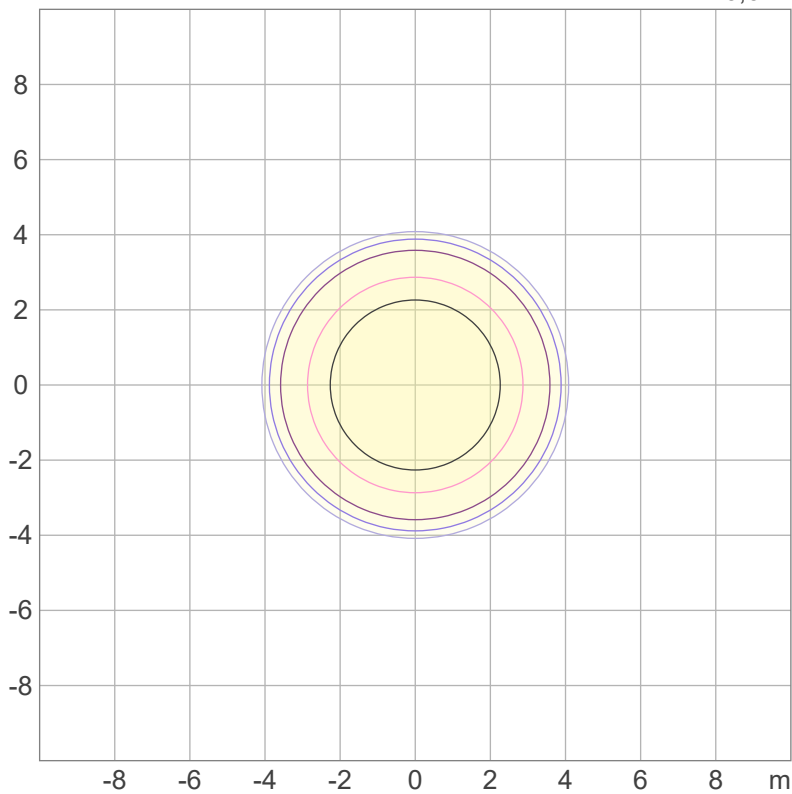

3%	1,26 lx
5%	2,10 lx
10%	4,20 lx
30%	12,6 lx
50%	21,0 lx

Conditions:

Number of c-planes: 2

Lux at center: 42,0 lx

*Lux distribution on a surface when lamp is mounted at 10 meters from the surface.*



Total lumen output:

402 lm

Peak candela output:

14889 cd

PRODUCT NAME:

ECLFRCTPM

MEASURAMENT CONDITIONS:

Beam angle:

Min Zoom

Target:

Red - HB

Operator:

Salvatore Giglio

Date and time:

03/10/2023 10:59:40

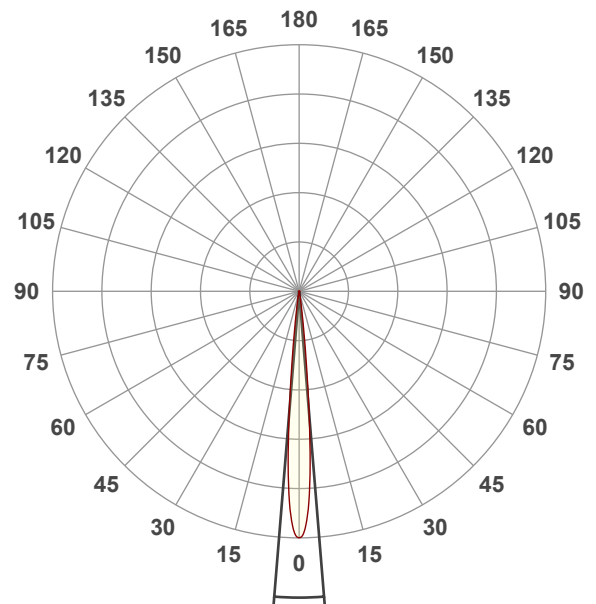

Beam angle 50%: 9,3°

Field angle 10%: 15,1°

Cut off angle 2.5%: 19,6°

Spectra

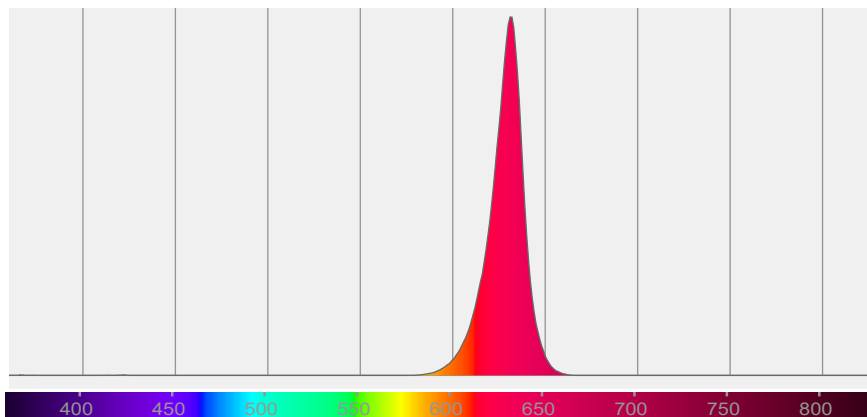

# BEAM DETAILS



Beam angle 50%	Field angle 10%	Cut off angle 2,5%	Intensity ratio in 120° cone	Intensity ratio in 90° cone
9,3°	15,1°	19,6°	100,0%	100,0%

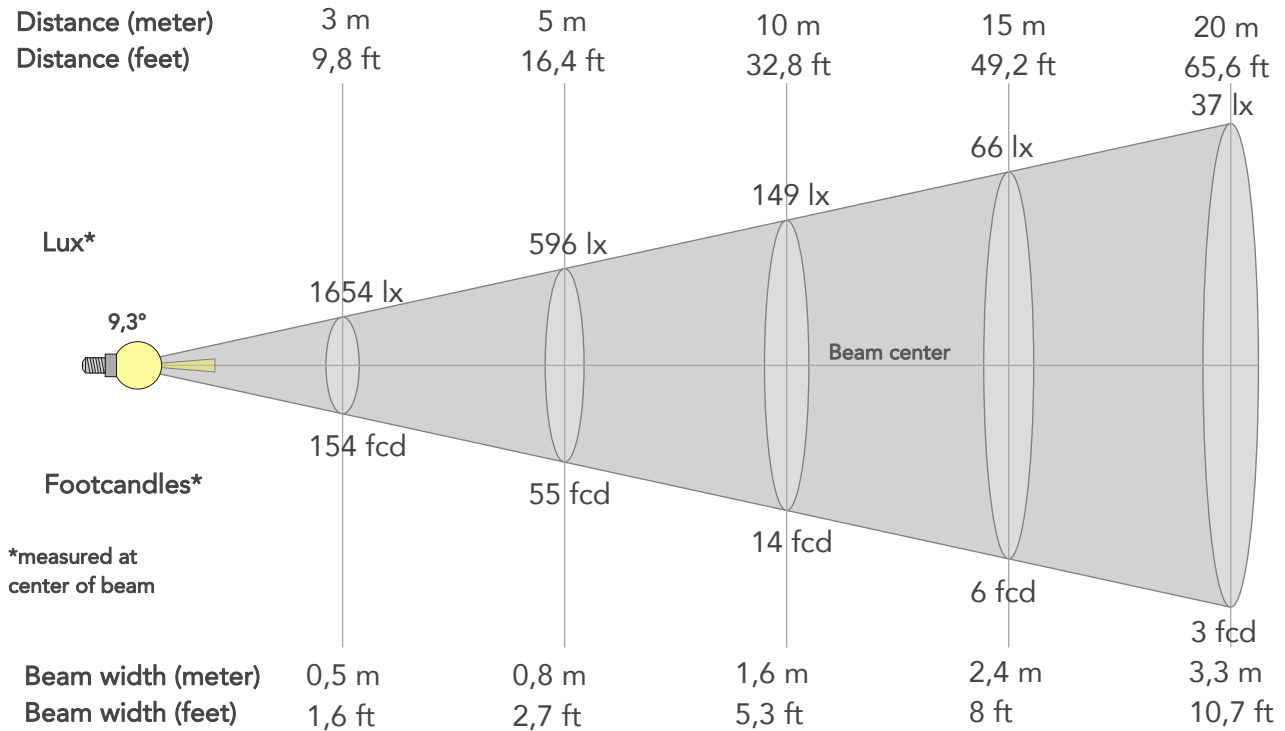

## BEAM INTENSITIES AND WIDTHS

Distance	1m	2m	3m	4m	5m	7,5m	10m	15m	20m	25m	30m	40m	50m
Distance	3,3ft	6,6ft	9,8ft	13,1ft	16,4ft	24,6ft	32,8ft	49,2ft	65,6ft	82ft	98,4ft	131,2ft	164ft
Lux	14889lx	3722lx	1654lx	931lx	596lx	265lx	149lx	66lx	37lx	24lx	17lx	9lx	6lx
Footcand.	1383fcd	346fcd	154fcd	86fcd	55fcd	25fcd	14fcd	6fcd	3fcd	2fcd	2fcd	1fcd	1fcd
Beam wid.	0,2m	0,3m	0,5m	0,7m	0,8m	1,2m	1,6m	2,4m	3,3m	4,1m	4,9m	6,5m	8,2m
Beam wid.	0,5ft	1,1ft	1,6ft	2,1ft	2,7ft	4ft	5,3ft	8ft	10,7ft	13,4ft	16ft	21,4ft	26,7ft

## LINEAR DISTRIBUTION DIAGRAM

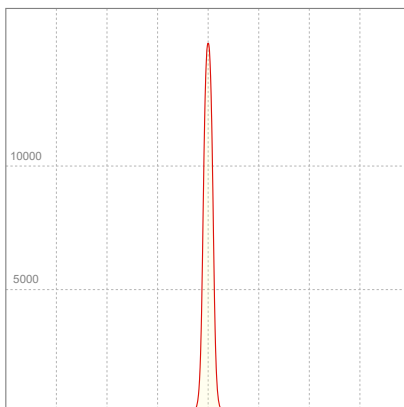

## ELECTRICAL SPECIFICATIONS

Input voltage	Input current	Input power	Effeciency
229V	0,343A	49,6W	8lm/W

Power FC
0,63

## ISO CANDELA DIAGRAM

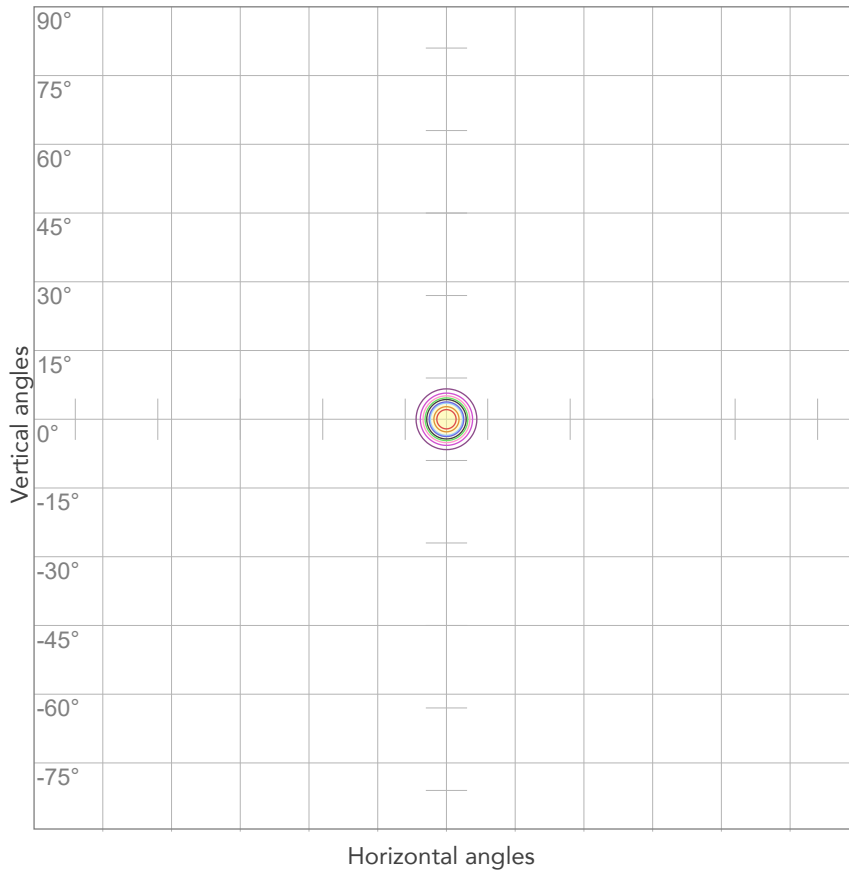

10%	1489 cd
20%	2978 cd
30%	4467 cd
40%	5956 cd
50%	7444 cd
60%	8933 cd
70%	10422 cd
80%	11911 cd

Conditions:

Number of c-planes: 2

Candela at center: 14889 cd

## ISO LUX DIAGRAM

MH: 10,0 m

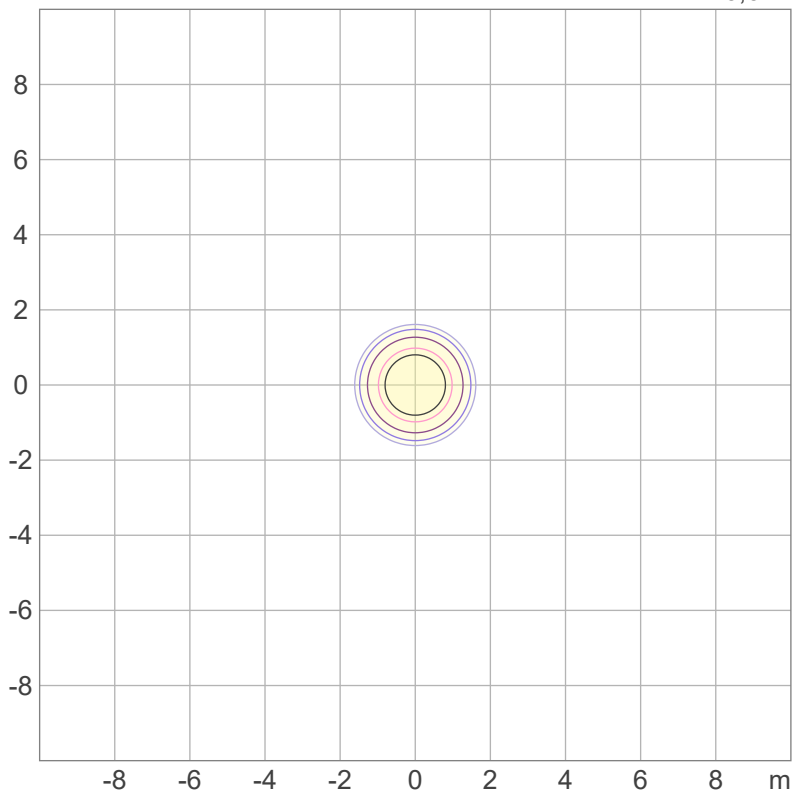

Mounting height: 10 meters (33 feet)

3%	4,47 lx
5%	7,44 lx
10%	14,9 lx
30%	44,7 lx
50%	74,4 lx

Conditions:

Number of c-planes: 2

Lux at center: 149 lx

*Lux distribution on a surface when lamp is mounted at 10 meters from the surface.*



Total lumen output:

1813 lm

Peak candela output:

1952 cd

PRODUCT NAME:

ECLFRCTPM

MEASURAMENT CONDITIONS:

Beam angle:

Max Zoom

Target:

Green - HB

Operator:

Salvatore Giglio

Date and time:

03/10/2023 10:50:23

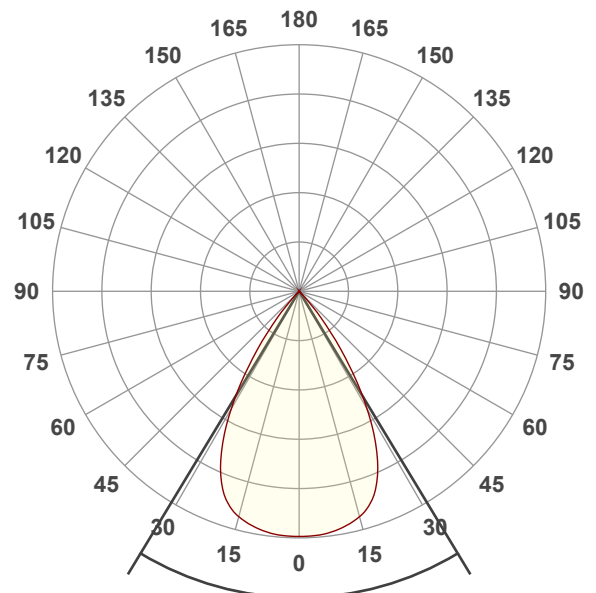

Beam angle 50%: 62,4°

Field angle 10%: 82°

Cut off angle 2.5%: 89,7°

Spectra

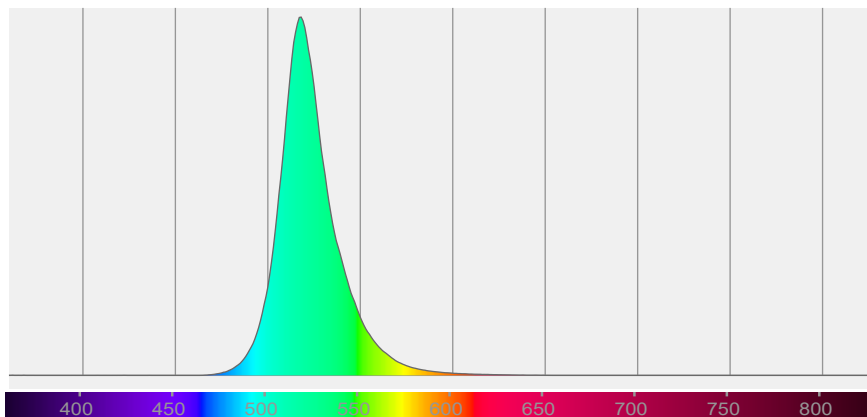

# BEAM DETAILS



Beam angle 50%	Field angle 10%	Cut off angle 2,5%	Intensity ratio in 120° cone	Intensity ratio in 90° cone
62,4°	82°	89,7°	99,9%	99,6%

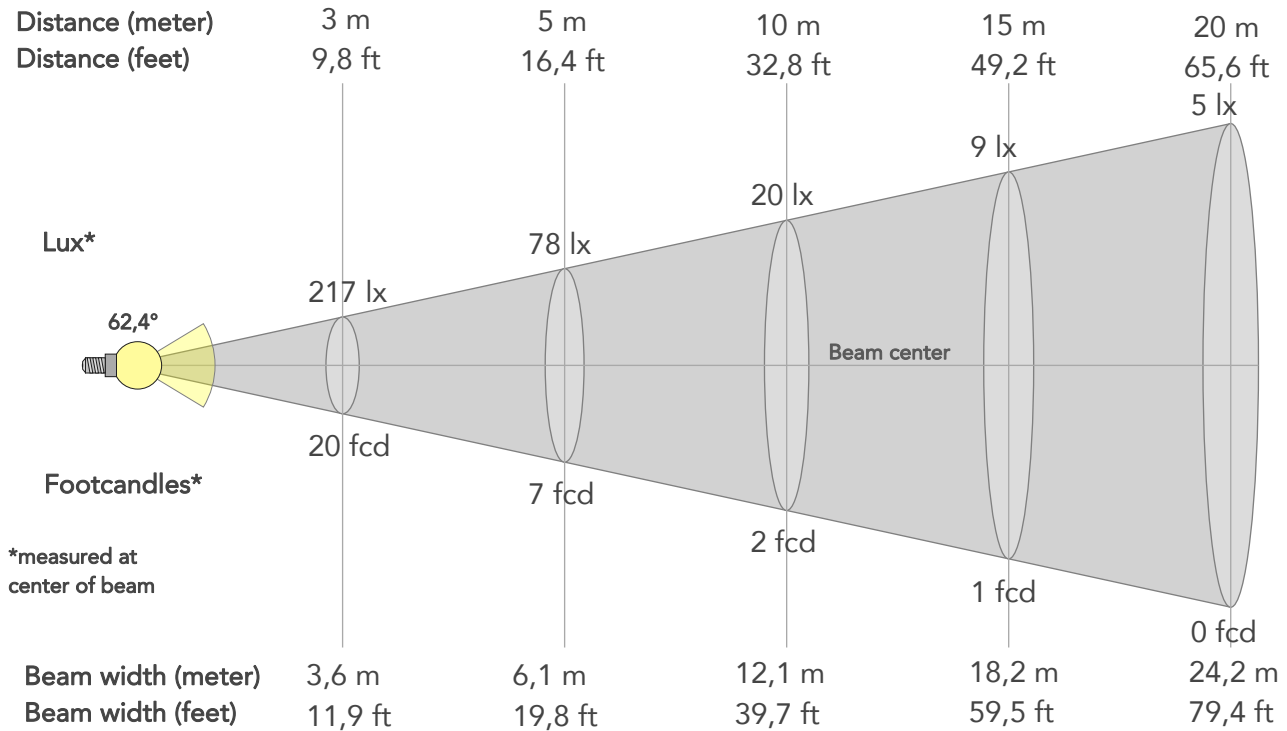

## BEAM INTENSITIES AND WIDTHS

Distance	1m	2m	3m	4m	5m	7,5m	10m	15m	20m	25m	30m	40m	50m
Distance	3,3ft	6,6ft	9,8ft	13,1ft	16,4ft	24,6ft	32,8ft	49,2ft	65,6ft	82ft	98,4ft	131,2ft	164ft
Lux	1952lx	488lx	217lx	122lx	78lx	35lx	20lx	9lx	5lx	3lx	2lx	1lx	1lx
Footcand.	181fcd	45fcd	20fcd	11fcd	7fcd	3fcd	2fcd	1fcd	0fcd	0fcd	0fcd	0fcd	0fcd
Beam wid.	1,2m	2,4m	3,6m	4,8m	6,1m	9,1m	12,1m	18,2m	24,2m	30,3m	36,3m	48,4m	60,5m
Beam wid.	4ft	8ft	11,9ft	15,9ft	19,8ft	29,8ft	39,7ft	59,5ft	79,4ft	99,2ft	119,1ft	158,8ft	198,5ft

## LINEAR DISTRIBUTION DIAGRAM

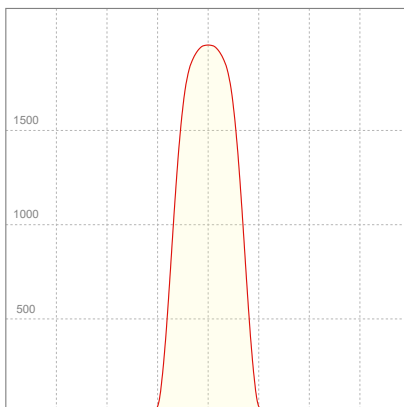

## ELECTRICAL SPECIFICATIONS

Input voltage	Input current	Input power	Effeciency
229V	0,356A	56,9W	32lm/W

Power FC
0,7



## ISO CANDELA DIAGRAM

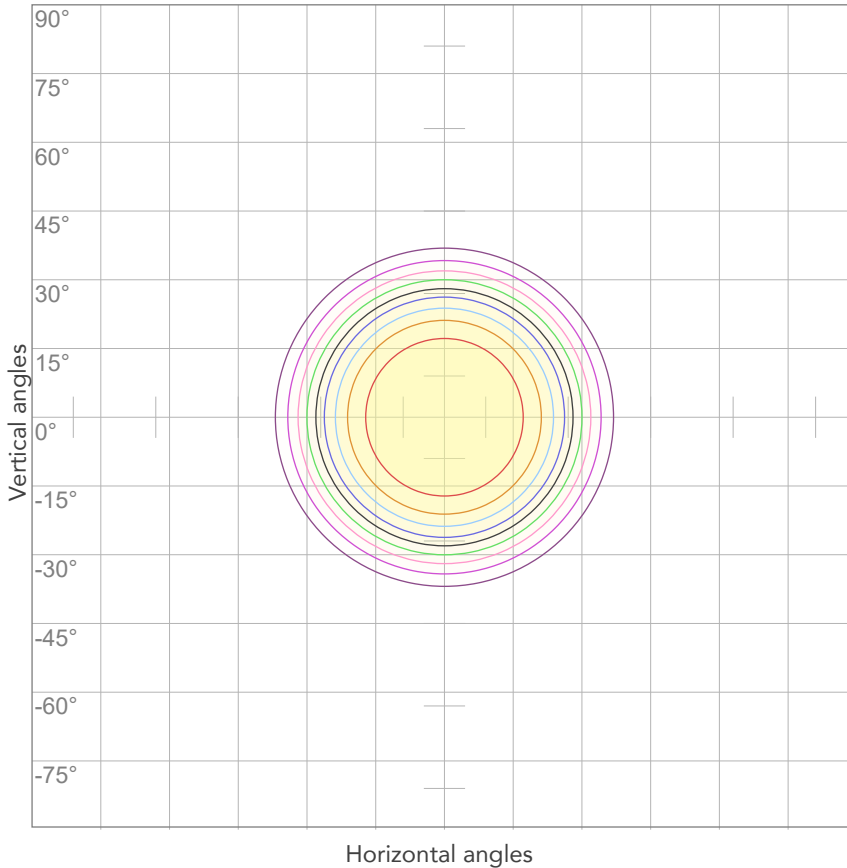

10%	195 cd
20%	390 cd
30%	586 cd
40%	781 cd
50%	976 cd
60%	1171 cd
70%	1367 cd
80%	1562 cd

Conditions:

Number of c-planes: 2

Candela at center: 1952 cd

## ISO LUX DIAGRAM

MH: 10,0 m

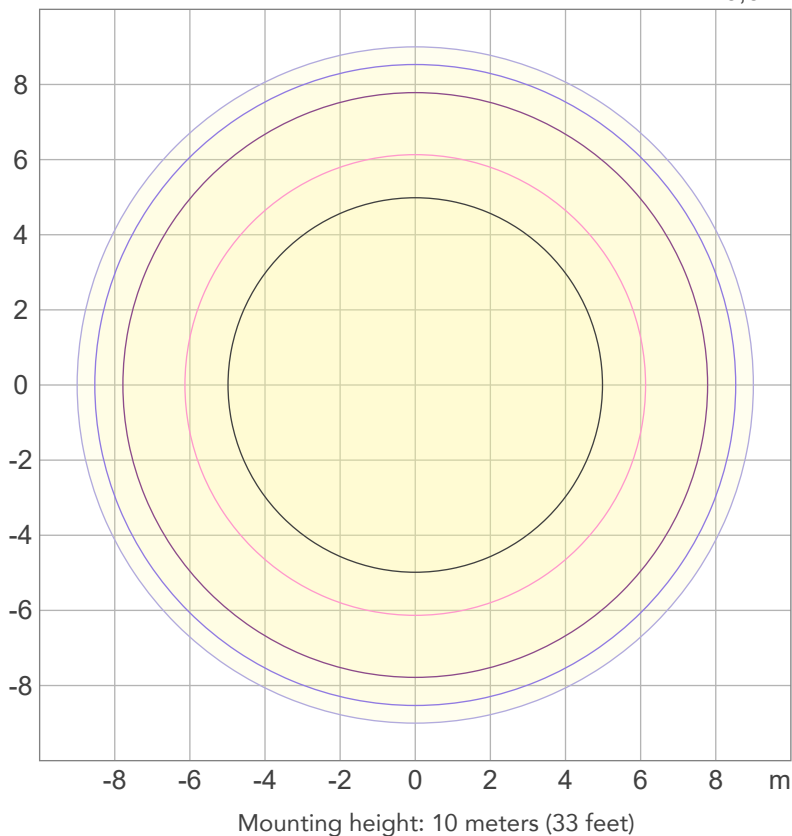

3%	0,586 lx
5%	0,976 lx
10%	1,95 lx
30%	5,86 lx
50%	9,76 lx

Conditions:

Number of c-planes: 2

Lux at center: 19,5 lx

*Lux distribution on a surface when lamp is mounted at 10 meters from the surface.*



Total lumen output:

1364 lm

Peak candela output:

6903 cd

PRODUCT NAME:

ECLFRCTPM

MEASURAMENT CONDITIONS:

Beam angle:

Med Zoom

Target:

Green - HB

Operator:

Salvatore Giglio

Date and time:

03/10/2023 12:09:40

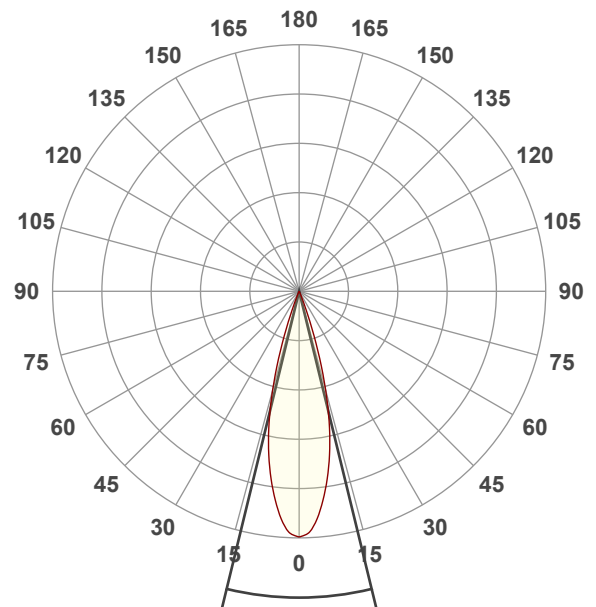

Beam angle 50%: 27,4°

Field angle 10%: 40,4°

Cut off angle 2.5%: 45,7°

Spectra

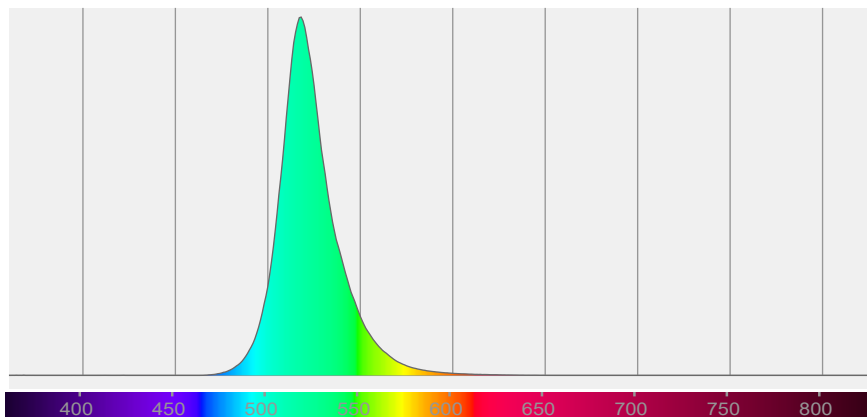

# BEAM DETAILS



Beam angle 50%	Field angle 10%	Cut off angle 2,5%	Intensity ratio in 120° cone	Intensity ratio in 90° cone
27,4°	40,4°	45,7°	100,0%	99,9%

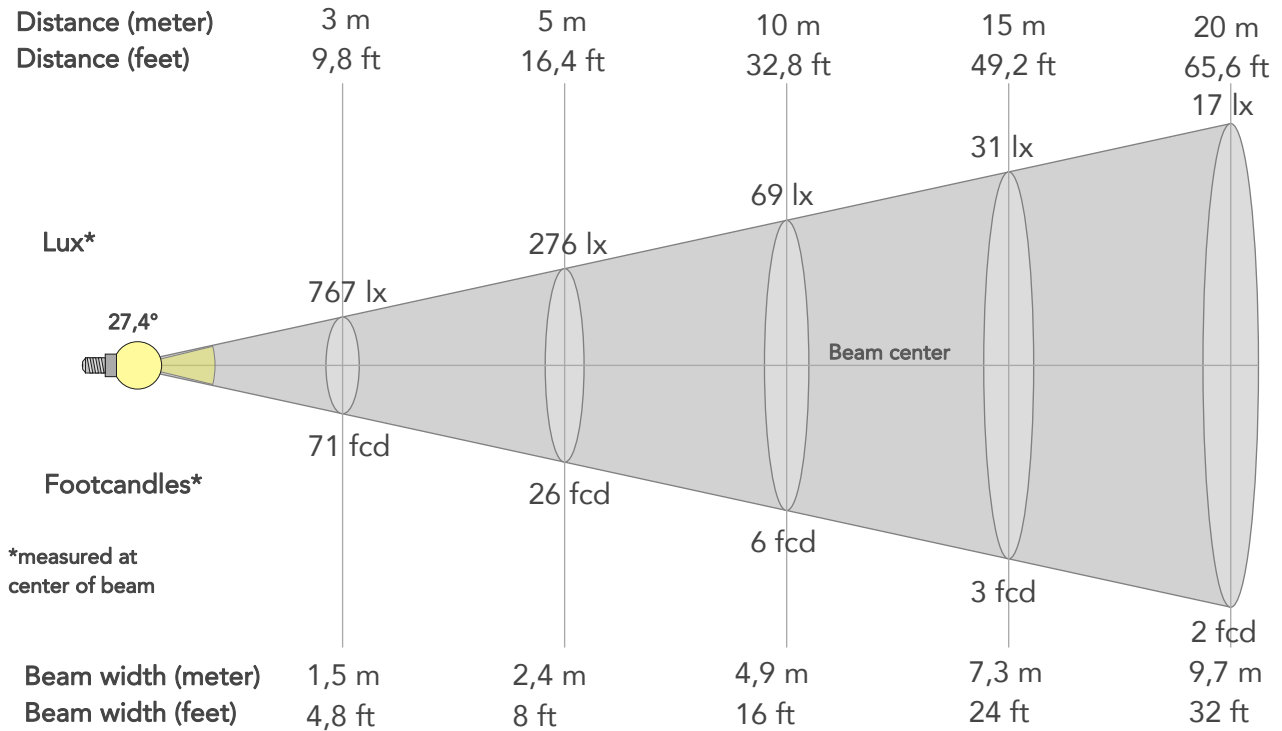

## BEAM INTENSITIES AND WIDTHS

Distance	1m	2m	3m	4m	5m	7,5m	10m	15m	20m	25m	30m	40m	50m
Distance	3,3ft	6,6ft	9,8ft	13,1ft	16,4ft	24,6ft	32,8ft	49,2ft	65,6ft	82ft	98,4ft	131,2ft	164ft
Lux	6903lx	1726lx	767lx	431lx	276lx	123lx	69lx	31lx	17lx	11lx	8lx	4lx	3lx
Footcand.	641fcd	160fcd	71fcd	40fcd	26fcd	11fcd	6fcd	3fcd	2fcd	1fcd	1fcd	0fcd	0fcd
Beam wid.	0,5m	1m	1,5m	1,9m	2,4m	3,7m	4,9m	7,3m	9,7m	12,2m	14,6m	19,5m	24,4m
Beam wid.	1,6ft	3,2ft	4,8ft	6,4ft	8ft	12ft	16ft	24ft	32ft	39,9ft	47,9ft	63,9ft	79,9ft

## LINEAR DISTRIBUTION DIAGRAM

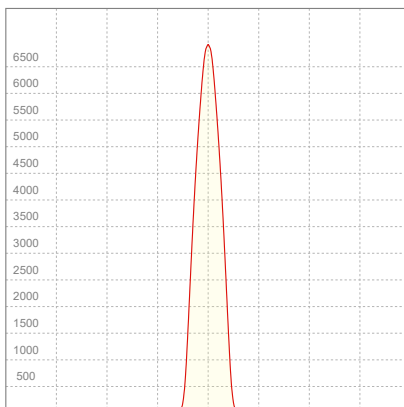

## ELECTRICAL SPECIFICATIONS

Input voltage	Input current	Input power	Effeciency
229V	0,356A	56,4W	24lm/W

Power FC
0,69

## ISO CANDELA DIAGRAM

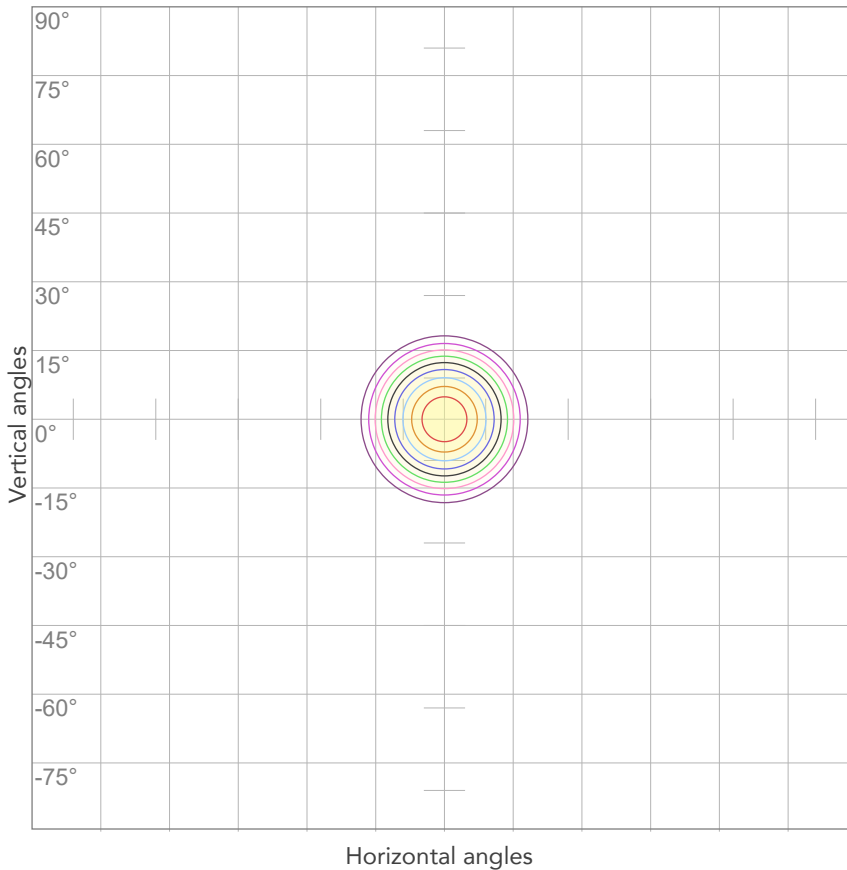

10%	690 cd
20%	1381 cd
30%	2071 cd
40%	2761 cd
50%	3452 cd
60%	4142 cd
70%	4832 cd
80%	5523 cd

Conditions:

Number of c-planes: 2

Candela at center: 6903 cd

## ISO LUX DIAGRAM

MH: 10,0 m

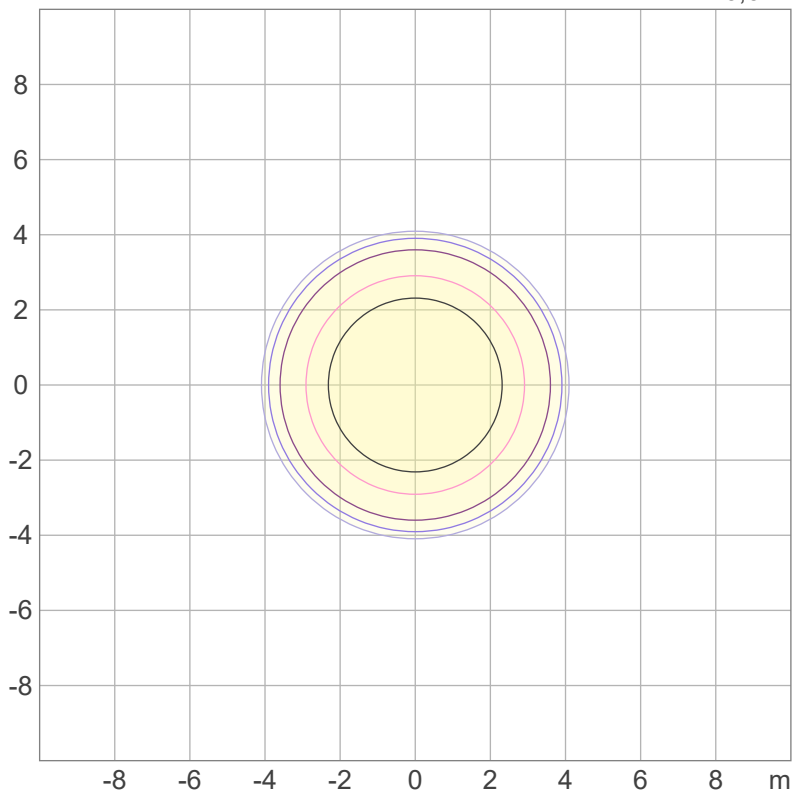

Mounting height: 10 meters (33 feet)

3%	2,07 lx
5%	3,45 lx
10%	6,90 lx
30%	20,7 lx
50%	34,5 lx

Conditions:

Number of c-planes: 2

Lux at center: 69,0 lx

*Lux distribution on a surface when lamp is mounted at 10 meters from the surface.*



Total lumen output:

705 lm

Peak candela output:

24749 cd

PRODUCT NAME:

ECLFRCTPM

MEASURAMENT CONDITIONS:

Beam angle:

Min Zoom

Target:

Green - HB

Operator:

Salvatore Giglio

Date and time:

03/10/2023 11:01:17

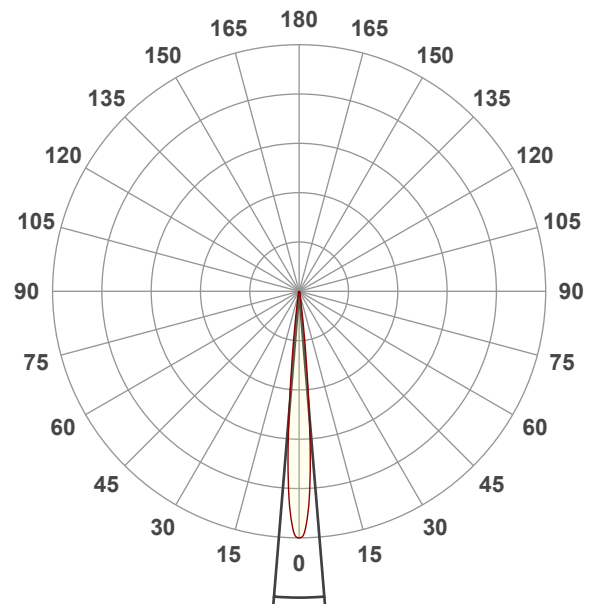

Beam angle 50%: 9,4°

Field angle 10%: 15,4°

Cut off angle 2.5%: 20,4°

Spectra

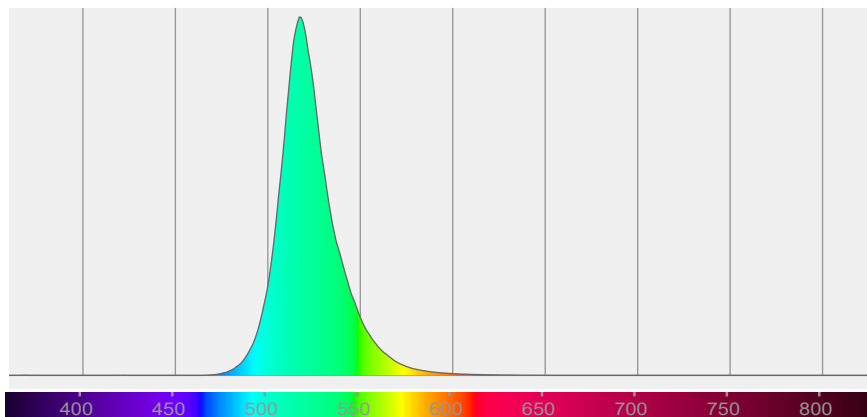

# BEAM DETAILS



Beam angle 50%	Field angle 10%	Cut off angle 2,5%	Intensity ratio in 120° cone	Intensity ratio in 90° cone
9,4°	15,4°	20,4°	100,0%	100,0%

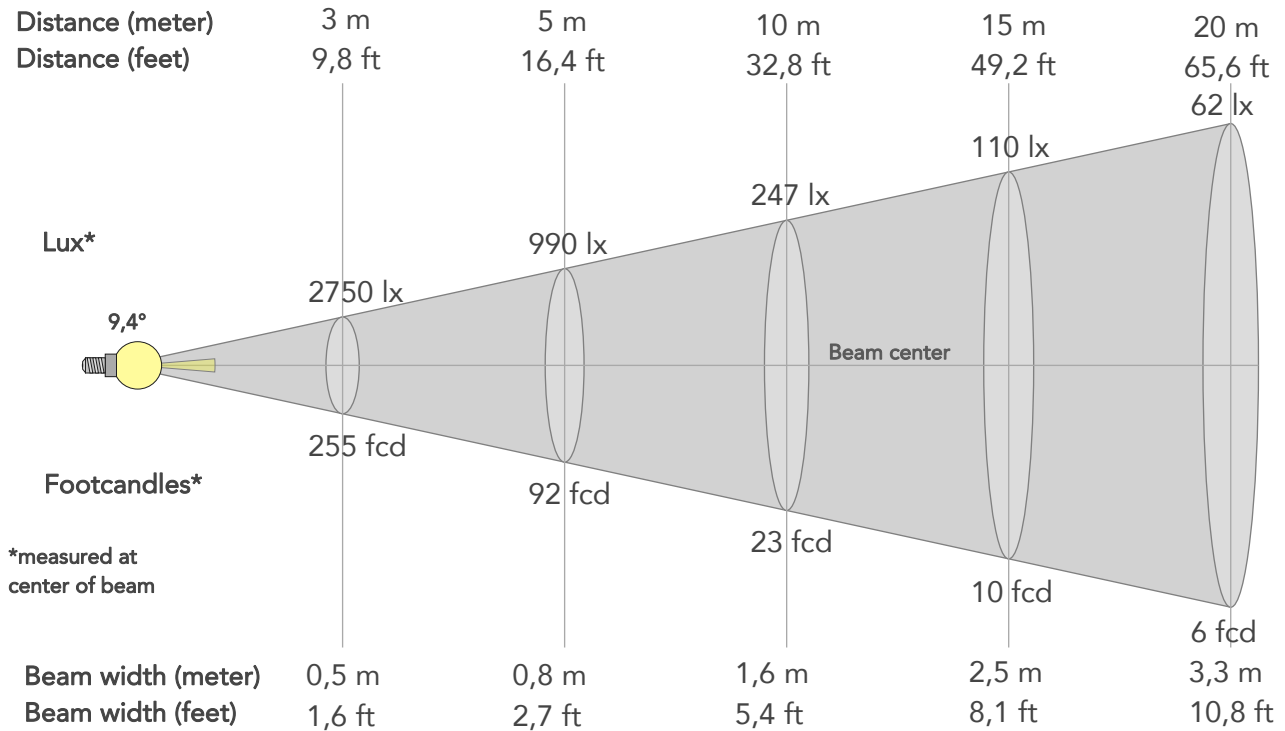

## BEAM INTENSITIES AND WIDTHS

Distance	1m	2m	3m	4m	5m	7,5m	10m	15m	20m	25m	30m	40m	50m
Distance	3,3ft	6,6ft	9,8ft	13,1ft	16,4ft	24,6ft	32,8ft	49,2ft	65,6ft	82ft	98,4ft	131,2ft	164ft
Lux	24749lx	6187lx	2750lx	1547lx	990lx	440lx	247lx	110lx	62lx	40lx	27lx	15lx	10lx
Footcand.	2299fcd	575fcd	255fcd	144fcd	92fcd	41fcd	23fcd	10fcd	6fcd	4fcd	3fcd	1fcd	1fcd
Beam wid.	0,2m	0,3m	0,5m	0,7m	0,8m	1,2m	1,6m	2,5m	3,3m	4,1m	4,9m	6,6m	8,2m
Beam wid.	0,5ft	1,1ft	1,6ft	2,2ft	2,7ft	4,1ft	5,4ft	8,1ft	10,8ft	13,5ft	16,2ft	21,6ft	27ft

## LINEAR DISTRIBUTION DIAGRAM

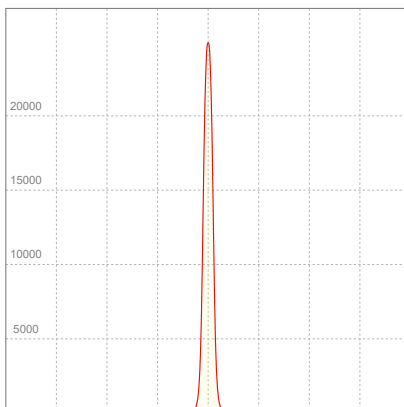

## ELECTRICAL SPECIFICATIONS

Input voltage	Input current	Input power	Effeciency
229V	0,354A	56,5W	12lm/W

Power FC
0,7

## ISO CANDELA DIAGRAM

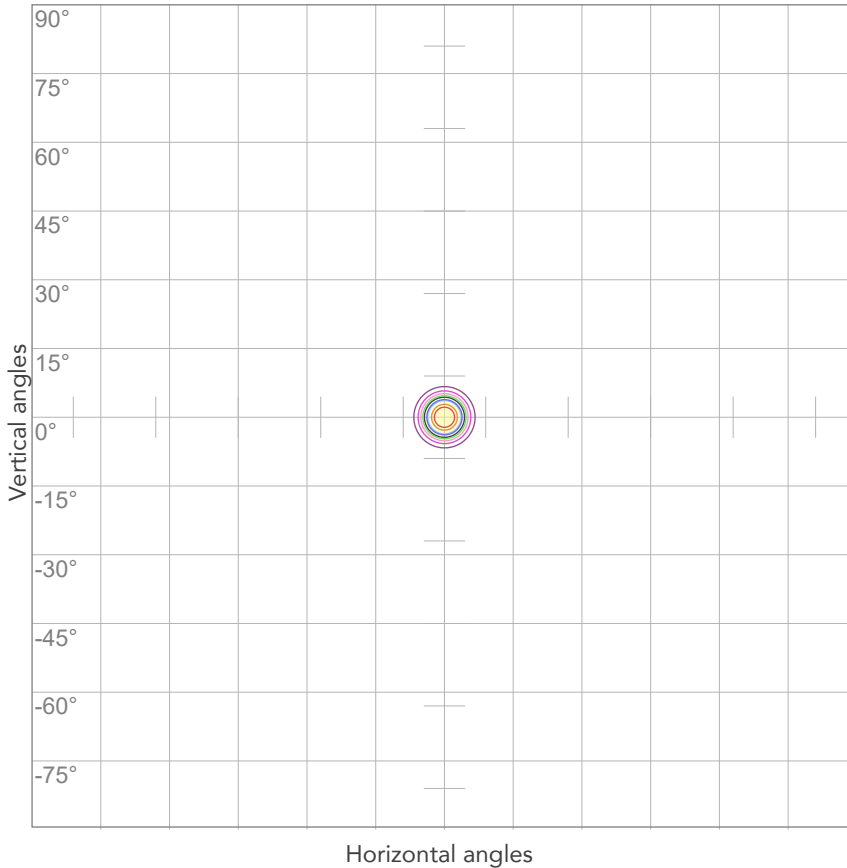

10%	2475 cd
20%	4950 cd
30%	7425 cd
40%	9900 cd
50%	12375 cd
60%	14849 cd
70%	17324 cd
80%	19799 cd

Conditions:

Number of c-planes: 2

Candela at center: 24749 cd

## ISO LUX DIAGRAM

MH: 10,0 m

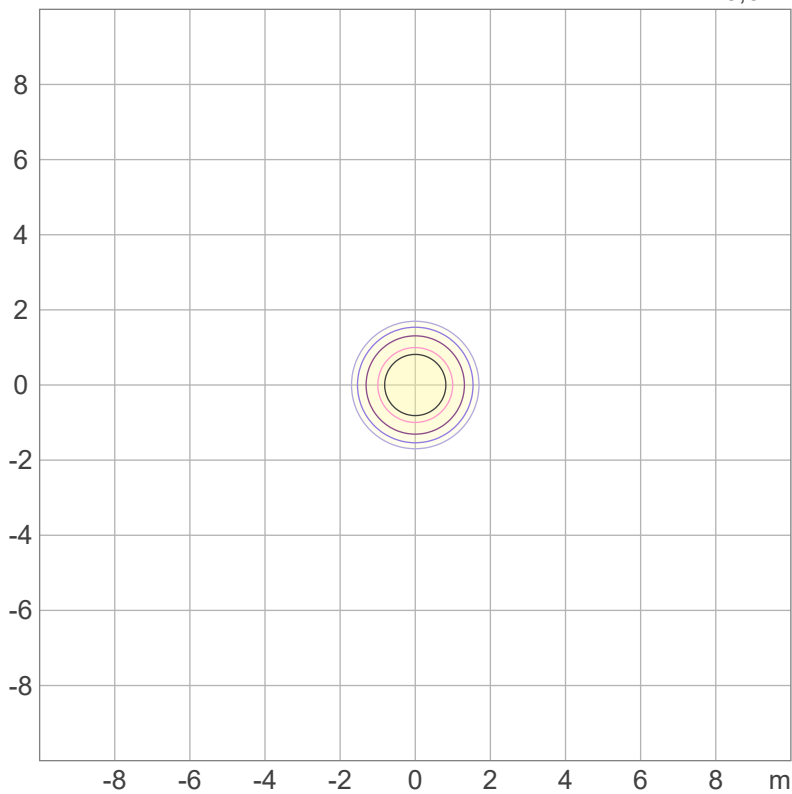

3%	7,42 lx
5%	12,4 lx
10%	24,7 lx
30%	74,2 lx
50%	124 lx

Conditions:

Number of c-planes: 2

Lux at center: 247 lx

*Lux distribution on a surface when lamp is mounted at 10 meters from the surface.*



Total lumen output:

285 lm

Peak candela output:

311 cd

PRODUCT NAME:

ECLFRCTPM

MEASURAMENT CONDITIONS:

Beam angle:

Max Zoom

Target:

Blue - HB

Operator:

Salvatore Giglio

Date and time:

03/10/2023 10:51:48

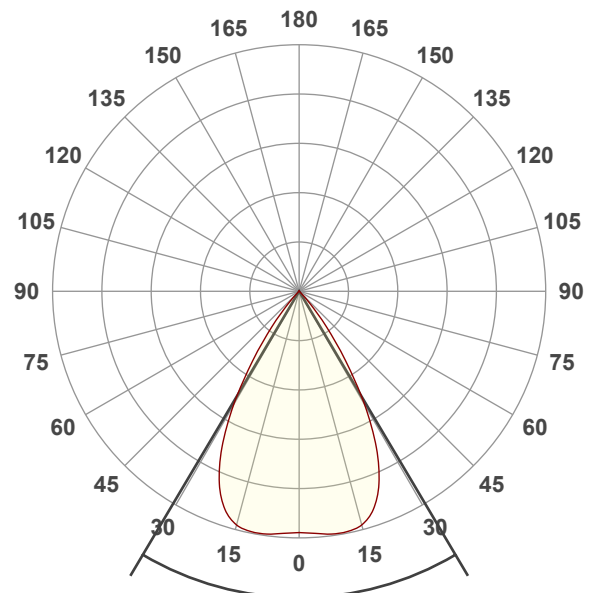

Beam angle 50%: 61,4°

Field angle 10%: 80,6°

Cut off angle 2.5%: 88,4°

Spectra

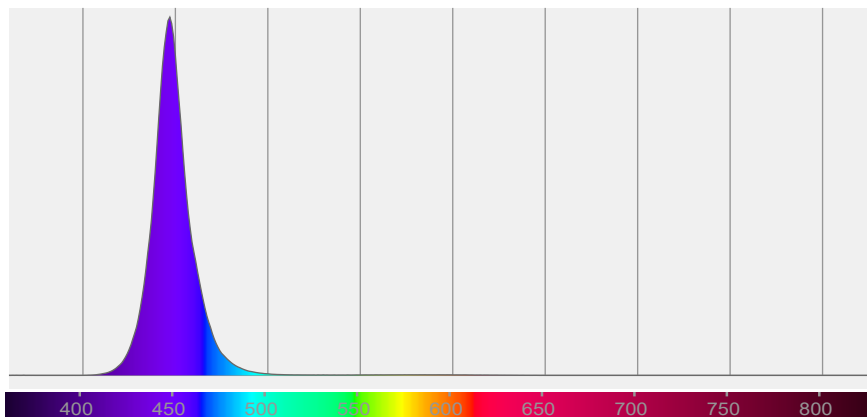



# BEAM DETAILS



Beam angle 50%	Field angle 10%	Cut off angle 2,5%	Intensity ratio in 120° cone	Intensity ratio in 90° cone
61,4°	80,6°	88,4°	99,9%	99,5%

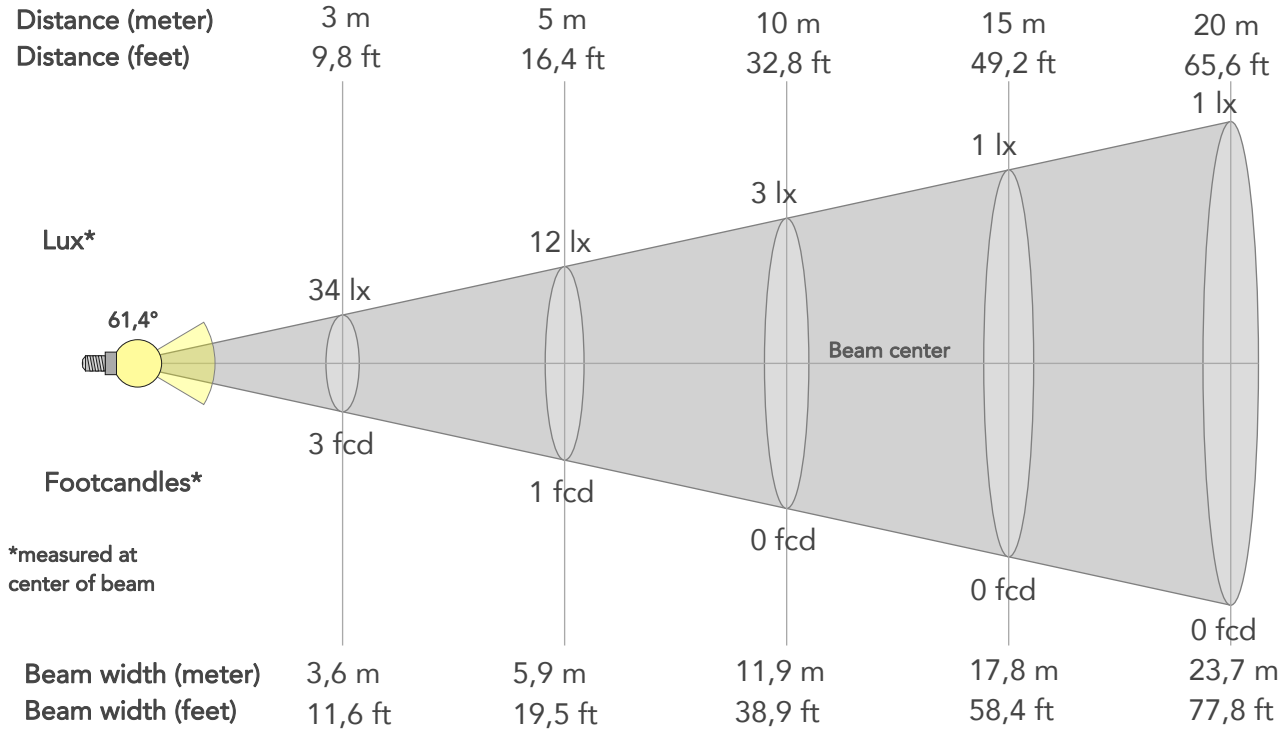

## BEAM INTENSITIES AND WIDTHS

Distance	1m	2m	3m	4m	5m	7,5m	10m	15m	20m	25m	30m	40m	50m
Distance	3,3ft	6,6ft	9,8ft	13,1ft	16,4ft	24,6ft	32,8ft	49,2ft	65,6ft	82ft	98,4ft	131,2ft	164ft
Lux	306lx	77lx	34lx	19lx	12lx	5lx	3lx	1lx	1lx	0lx	0lx	0lx	0lx
Footcand.	28fcd	7fcd	3fcd	2fcd	1fcd	1fcd	0fcd	0fcd	0fcd	0fcd	0fcd	0fcd	0fcd
Beam wid.	1,2m	2,4m	3,6m	4,7m	5,9m	8,9m	11,9m	17,8m	23,7m	29,7m	35,6m	47,5m	59,3m
Beam wid.	3,9ft	7,8ft	11,6ft	15,5ft	19,5ft	29,2ft	38,9ft	58,4ft	77,8ft	97,3ft	116,8ft	155,7ft	194,6ft

## LINEAR DISTRIBUTION DIAGRAM

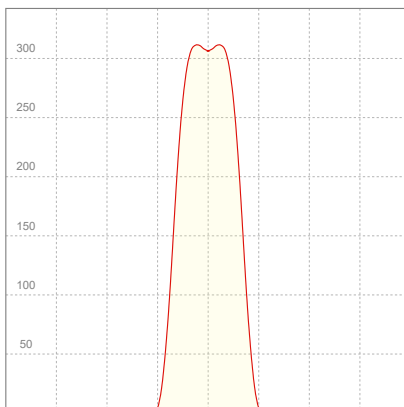

## ELECTRICAL SPECIFICATIONS

Input voltage	Input current	Input power	Effeciency
229V	0,353A	54,7W	5lm/W

Power FC
0,68

## ISO CANDELA DIAGRAM

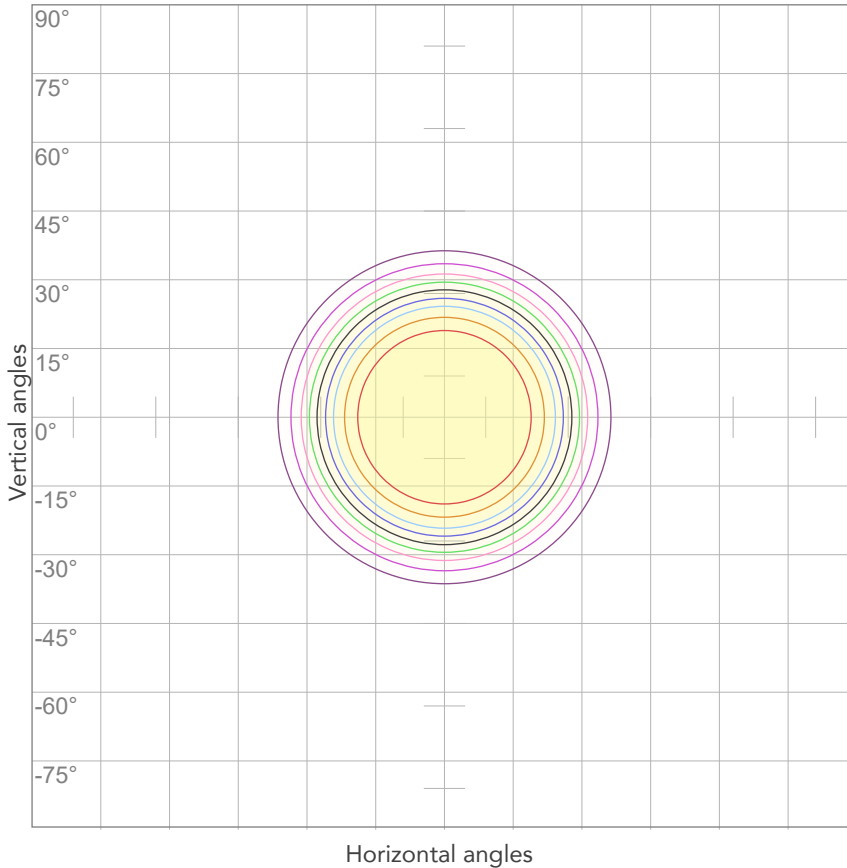

10%	31 cd
20%	61 cd
30%	92 cd
40%	123 cd
50%	153 cd
60%	184 cd
70%	214 cd
80%	245 cd

Conditions:

Number of c-planes: 2  
Candela at center: 306 cd

## ISO LUX DIAGRAM

MH: 10,0 m

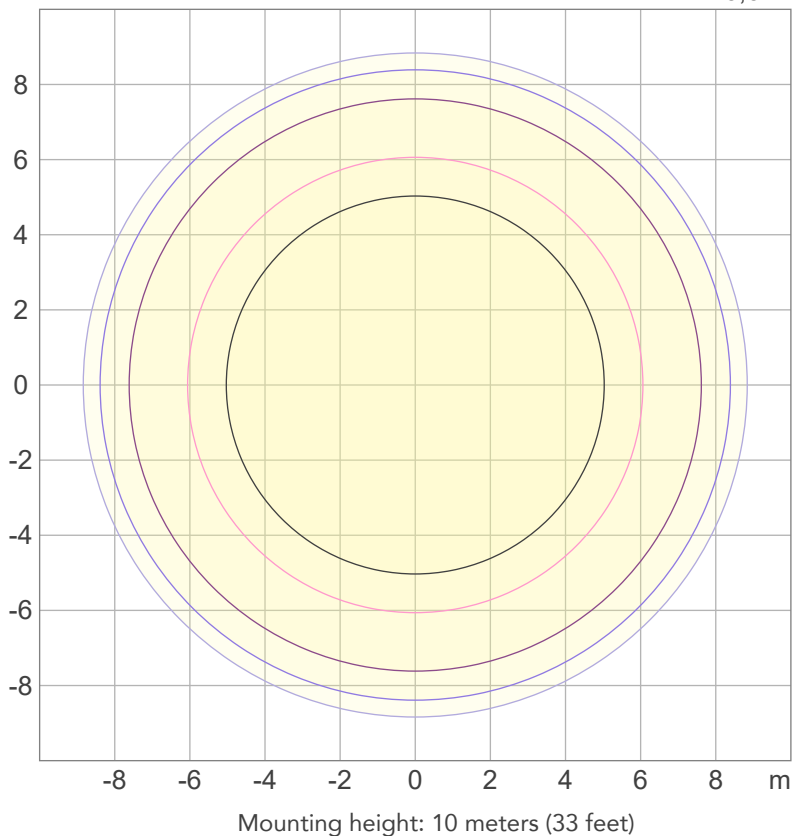

3%	91,9m lx
5%	0,153 lx
10%	0,306 lx
30%	0,919 lx
50%	1,53 lx

Conditions:

Number of c-planes: 2  
Lux at center: 3,06 lx

*Lux distribution on a surface when lamp is mounted at 10 meters from the surface.*



Total lumen output:

212 lm

Peak candela output:

1102 cd

**PRODUCT NAME:**

ECLFRCTPM

**MEASUREMENT CONDITIONS:**

Beam angle:

Med Zoom

Target:

Blue - HB

Operator:

Salvatore Giglio

Date and time:

03/10/2023 12:11:15

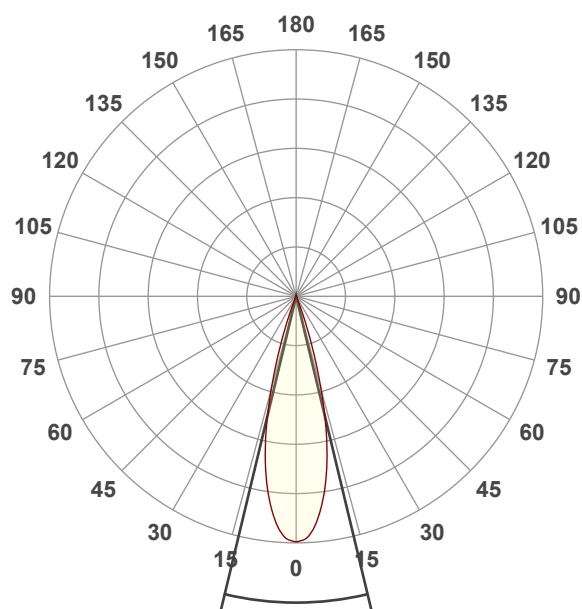

Beam angle 50%: 27°

Field angle 10%: 39,8°

Cut off angle 2.5%: 44,9°

Spectra

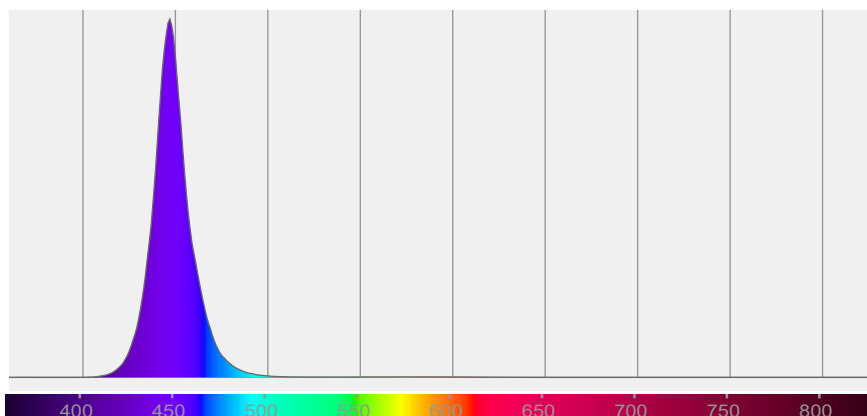

# BEAM DETAILS



Beam angle 50%	Field angle 10%	Cut off angle 2,5%	Intensity ratio in 120° cone	Intensity ratio in 90° cone
27°	39,8°	44,9°	100,0%	99,9%

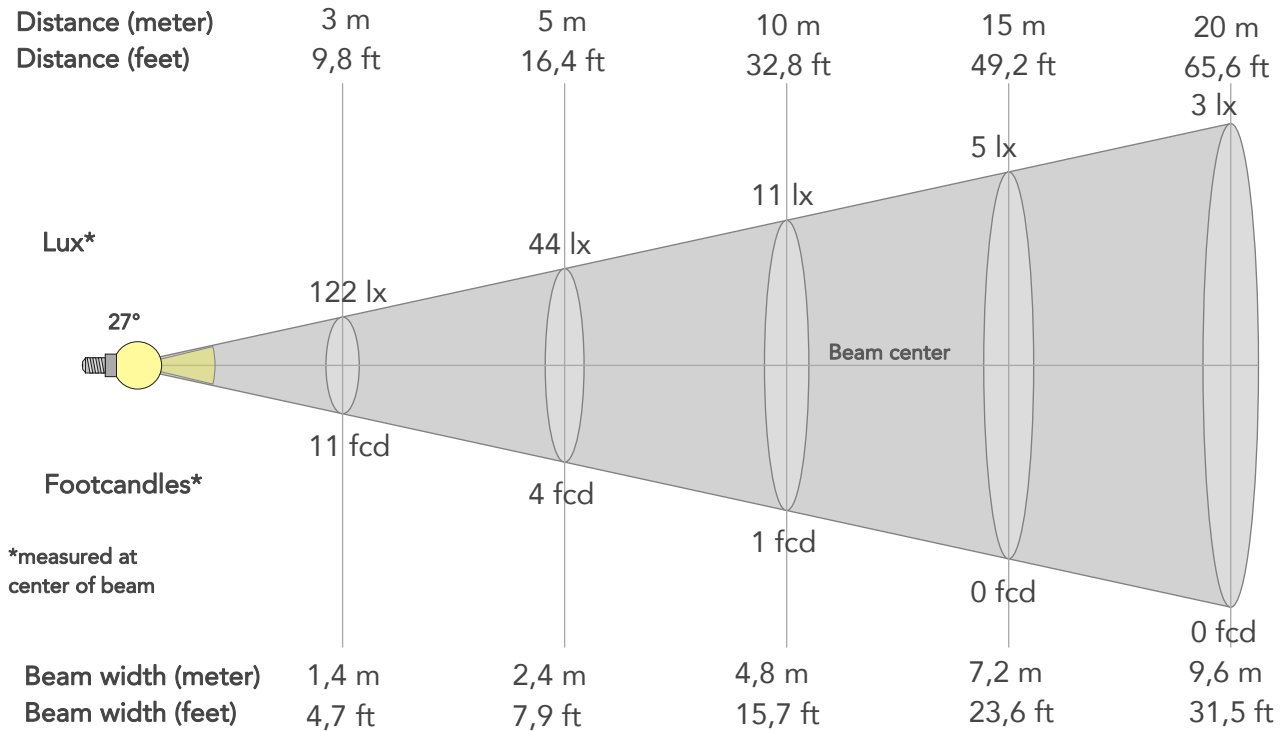

## BEAM INTENSITIES AND WIDTHS

Distance	1m	2m	3m	4m	5m	7,5m	10m	15m	20m	25m	30m	40m	50m
Distance	3,3ft	6,6ft	9,8ft	13,1ft	16,4ft	24,6ft	32,8ft	49,2ft	65,6ft	82ft	98,4ft	131,2ft	164ft
Lux	1102lx	275lx	122lx	69lx	44lx	20lx	11lx	5lx	3lx	2lx	1lx	1lx	0lx
Footcand.	102fcd	26fcd	11fcd	6fcd	4fcd	2fcd	1fcd	0fcd	0fcd	0fcd	0fcd	0fcd	0fcd
Beam wid.	0,5m	1m	1,4m	1,9m	2,4m	3,6m	4,8m	7,2m	9,6m	12m	14,4m	19,2m	24m
Beam wid.	1,6ft	3,2ft	4,7ft	6,3ft	7,9ft	11,8ft	15,7ft	23,6ft	31,5ft	39,3ft	47,2ft	62,9ft	78,7ft

## LINEAR DISTRIBUTION DIAGRAM

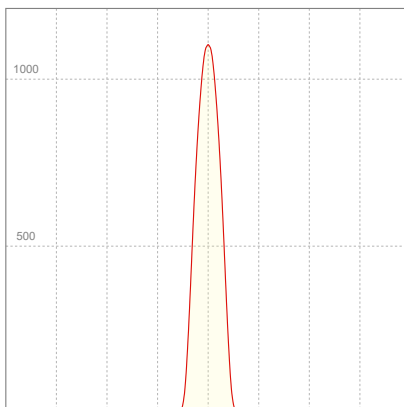

## ELECTRICAL SPECIFICATIONS

Input voltage	Input current	Input power	Effeciency
229V	0,351A	54,6W	4lm/W

Power FC
0,68

## ISO CANDELA DIAGRAM

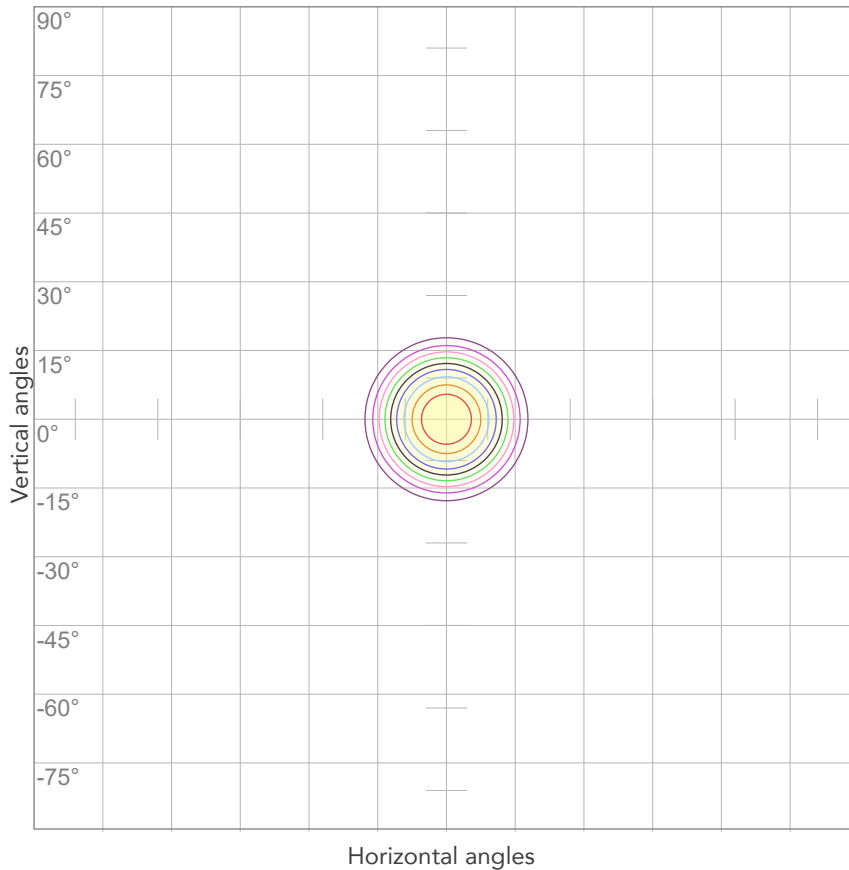

10%	110 cd
20%	220 cd
30%	330 cd
40%	441 cd
50%	551 cd
60%	661 cd
70%	771 cd
80%	881 cd

Conditions:

Number of c-planes: 2

Candela at center: 1102 cd

## ISO LUX DIAGRAM

MH: 10,0 m

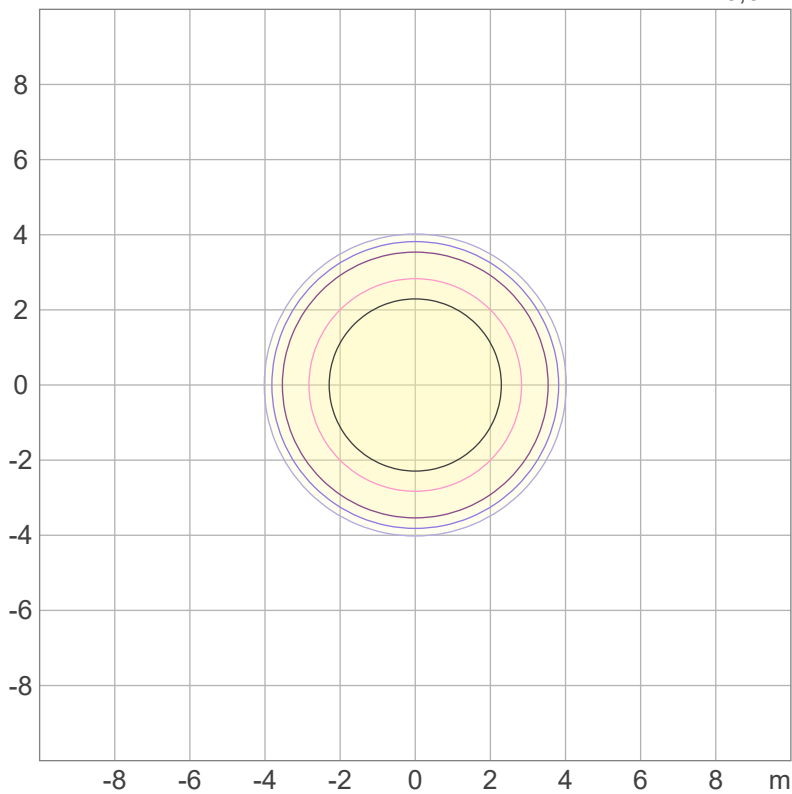

Mounting height: 10 meters (33 feet)

3%	0,330 lx
5%	0,551 lx
10%	1,10 lx
30%	3,30 lx
50%	5,51 lx

Conditions:

Number of c-planes: 2

Lux at center: 11,0 lx

*Lux distribution on a surface when lamp is mounted at 10 meters from the surface.*



Total lumen output:

113 lm

Peak candela output:

3969 cd

PRODUCT NAME:

ECLFRCTPM

MEASURAMENT CONDITIONS:

Beam angle:

Min Zoom

Target:

Blue - HB

Operator:

Salvatore Giglio

Date and time:

03/10/2023 11:02:59

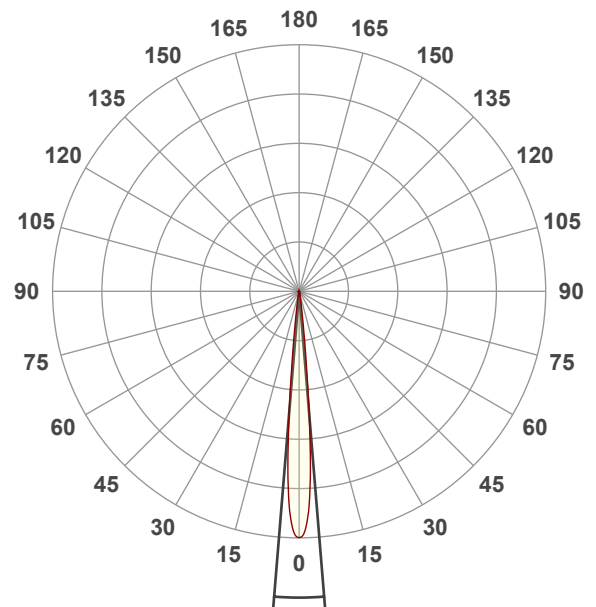

Beam angle 50%: 9,4°

Field angle 10%: 15,1°

Cut off angle 2.5%: 20,1°

Spectra

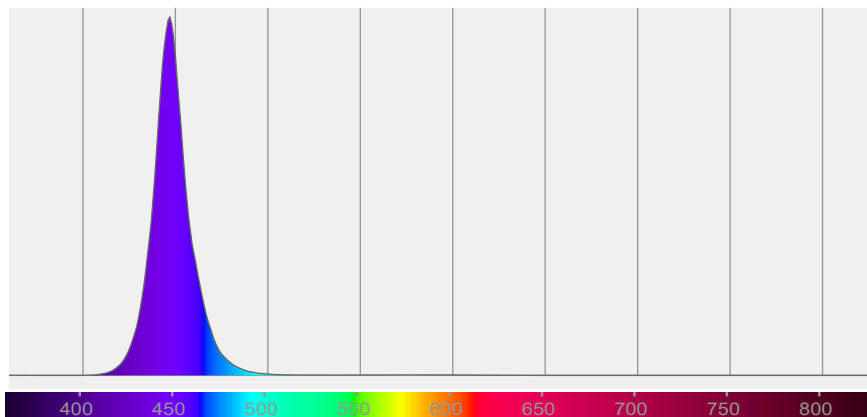

# BEAM DETAILS



Beam angle 50%	Field angle 10%	Cut off angle 2,5%	Intensity ratio in 120° cone	Intensity ratio in 90° cone
9,4°	15,1°	20,1°	100,0%	99,9%

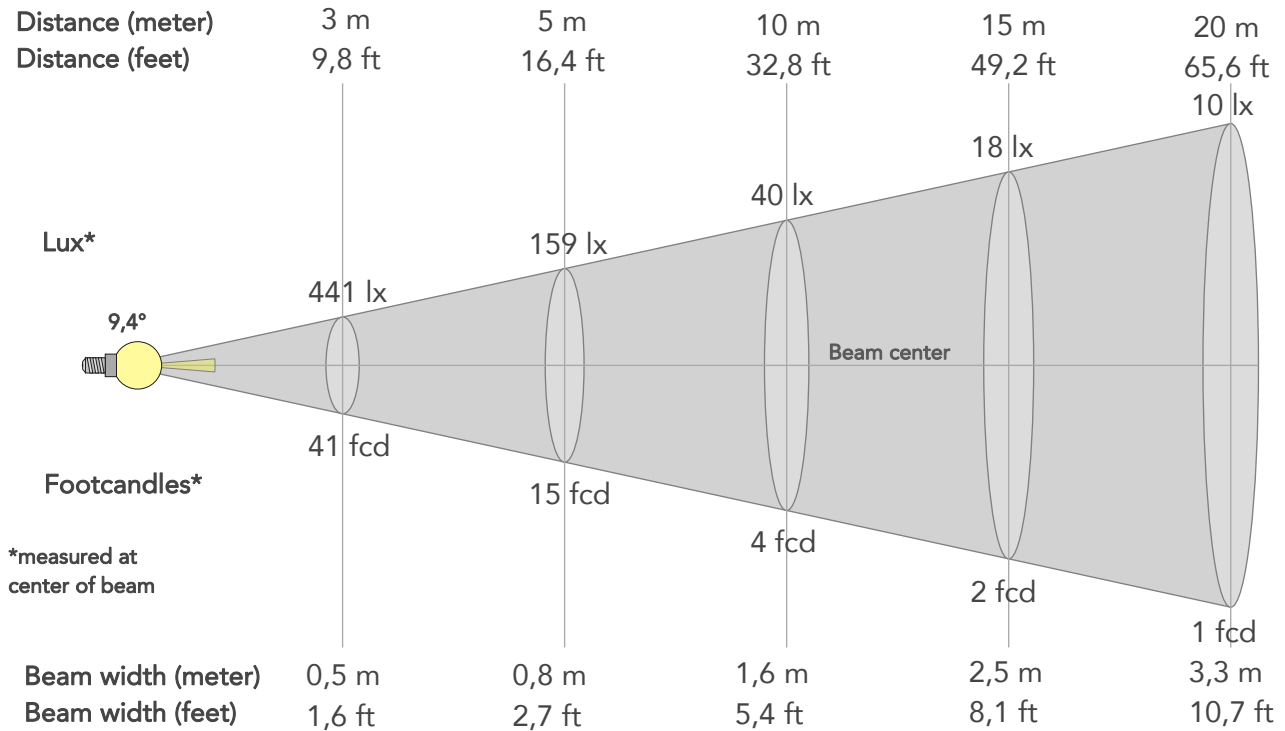

## BEAM INTENSITIES AND WIDTHS

Distance	1m	2m	3m	4m	5m	7,5m	10m	15m	20m	25m	30m	40m	50m
Distance	3,3ft	6,6ft	9,8ft	13,1ft	16,4ft	24,6ft	32,8ft	49,2ft	65,6ft	82ft	98,4ft	131,2ft	164ft
Lux	3969lx	992lx	441lx	248lx	159lx	71lx	40lx	18lx	10lx	6lx	4lx	2lx	2lx
Footcand.	369fcd	92fcd	41fcd	23fcd	15fcd	7fcd	4fcd	2fcd	1fcd	1fcd	0fcd	0fcd	0fcd
Beam wid.	0,2m	0,3m	0,5m	0,7m	0,8m	1,2m	1,6m	2,5m	3,3m	4,1m	4,9m	6,6m	8,2m
Beam wid.	0,5ft	1,1ft	1,6ft	2,1ft	2,7ft	4ft	5,4ft	8,1ft	10,7ft	13,4ft	16,1ft	21,5ft	26,9ft

## LINEAR DISTRIBUTION DIAGRAM

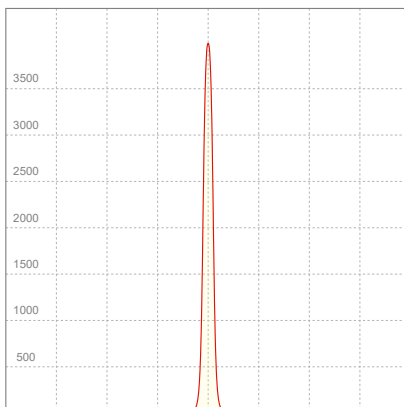

## ELECTRICAL SPECIFICATIONS

Input voltage	Input current	Input power	Effeciency
229V	0,352A	54,8W	2lm/W

Power FC
0,68

## ISO CANDELA DIAGRAM

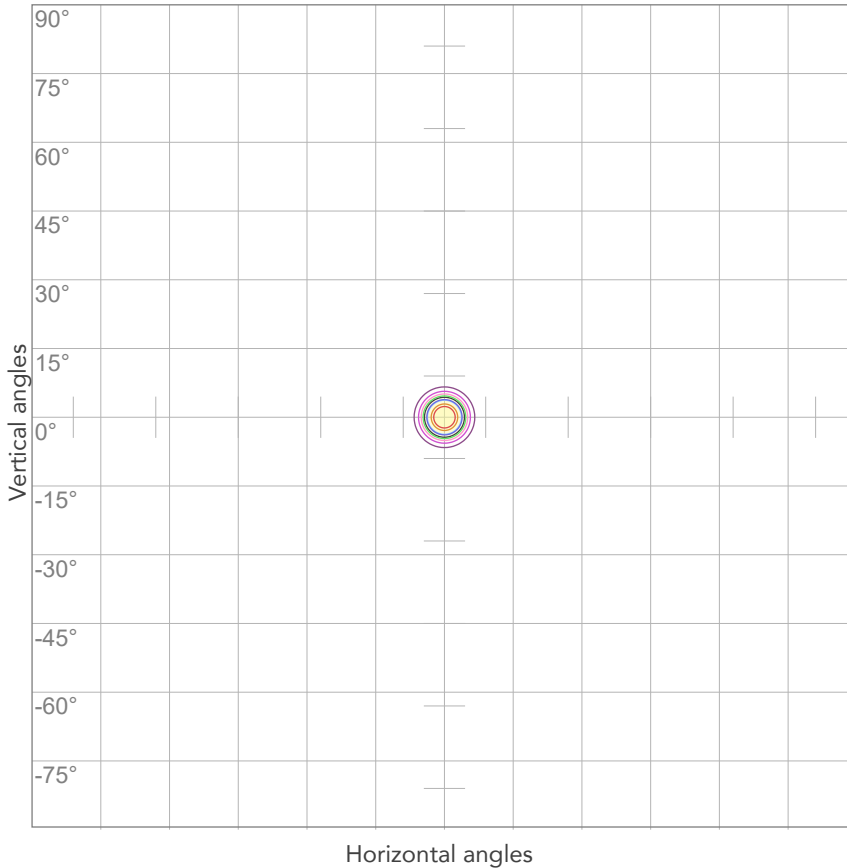

10%	397 cd
20%	794 cd
30%	1191 cd
40%	1588 cd
50%	1985 cd
60%	2381 cd
70%	2778 cd
80%	3175 cd

Conditions:

Number of c-planes: 2

Candela at center: 3969 cd

## ISO LUX DIAGRAM

MH: 10,0 m

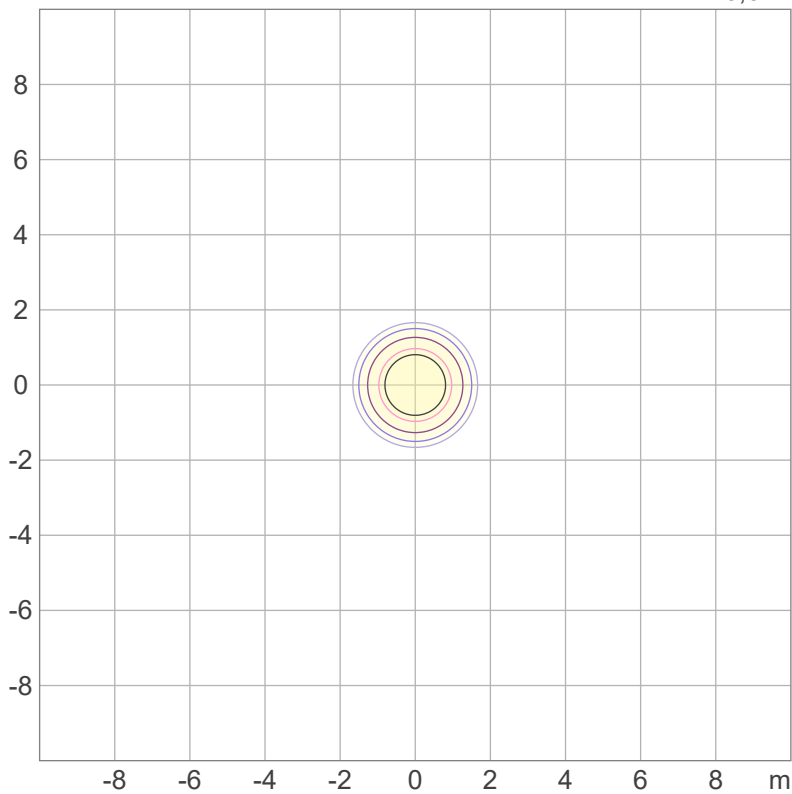

3%	1,19 lx
5%	1,98 lx
10%	3,97 lx
30%	11,9 lx
50%	19,8 lx

Conditions:

Number of c-planes: 2

Lux at center: 39,7 lx

*Lux distribution on a surface when lamp is mounted at 10 meters from the surface.*





Total lumen output:

396 lm

Peak candela output:

421 cd

PRODUCT NAME:

ECLFRCTPM

MEASUREMENT CONDITIONS:

Beam angle:

Max Zoom

Target:

Cyan - HB

Operator:

Salvatore Giglio

Date and time:

03/10/2023 10:54:21

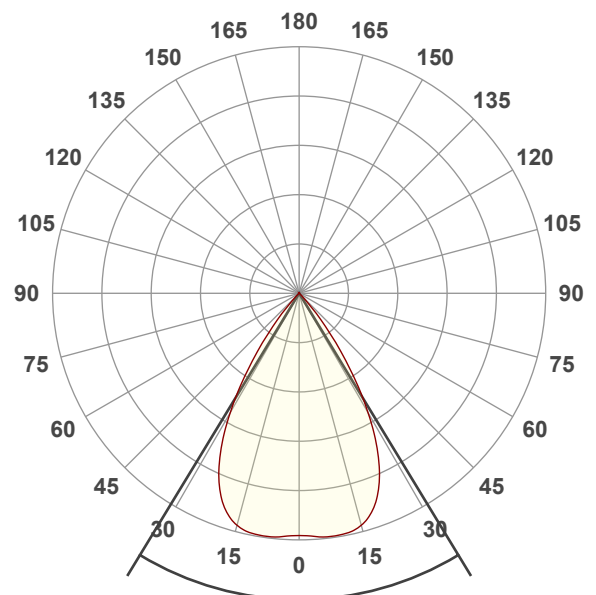

Beam angle 50%: 62,6°

Field angle 10%: 81,7°

Cut off angle 2.5%: 89,1°

Spectra

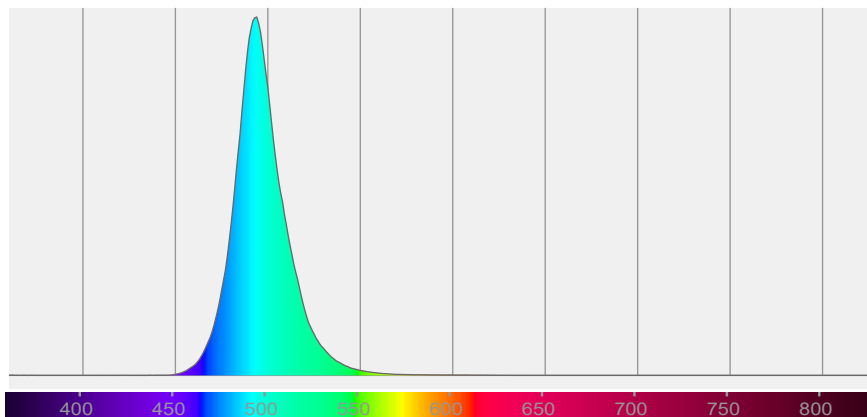

# BEAM DETAILS



Beam angle 50%	Field angle 10%	Cut off angle 2,5%	Intensity ratio in 120° cone	Intensity ratio in 90° cone
62,6°	81,7°	89,1°	100,0%	99,7%

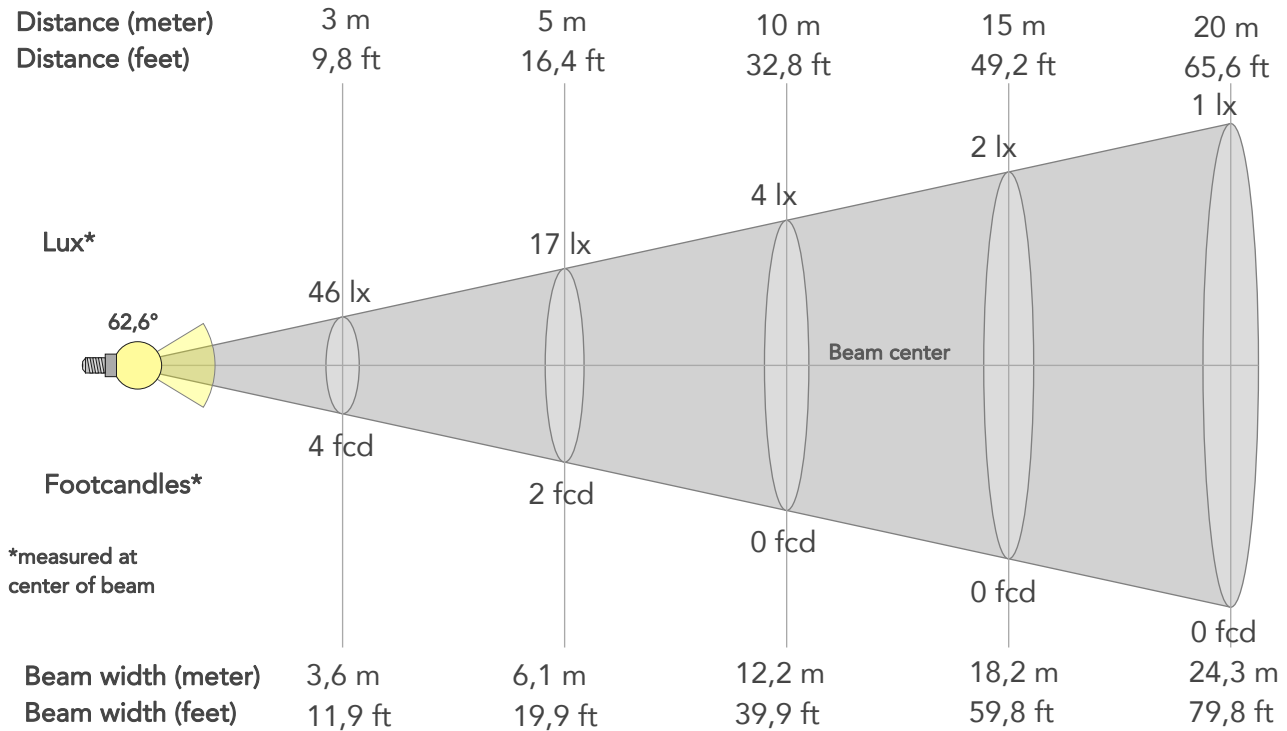

## BEAM INTENSITIES AND WIDTHS

Distance	1m	2m	3m	4m	5m	7,5m	10m	15m	20m	25m	30m	40m	50m
Distance	3,3ft	6,6ft	9,8ft	13,1ft	16,4ft	24,6ft	32,8ft	49,2ft	65,6ft	82ft	98,4ft	131,2ft	164ft
Lux	416lx	104lx	46lx	26lx	17lx	7lx	4lx	2lx	1lx	1lx	0lx	0lx	0lx
Footcand.	39fcd	10fcd	4fcd	2fcd	2fcd	1fcd	0fcd	0fcd	0fcd	0fcd	0fcd	0fcd	0fcd
Beam wid.	1,2m	2,4m	3,6m	4,9m	6,1m	9,1m	12,2m	18,2m	24,3m	30,4m	36,5m	48,7m	60,8m
Beam wid.	4ft	8ft	11,9ft	15,9ft	19,9ft	29,9ft	39,9ft	59,8ft	79,8ft	99,7ft	119,7ft	159,6ft	199,5ft

## LINEAR DISTRIBUTION DIAGRAM

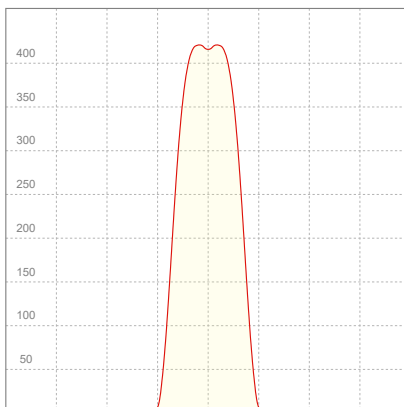

## ELECTRICAL SPECIFICATIONS

Input voltage	Input current	Input power	Effeciency
230V	0,312A	28,6W	14lm/W

Power FC
0,4

## ISO CANDELA DIAGRAM

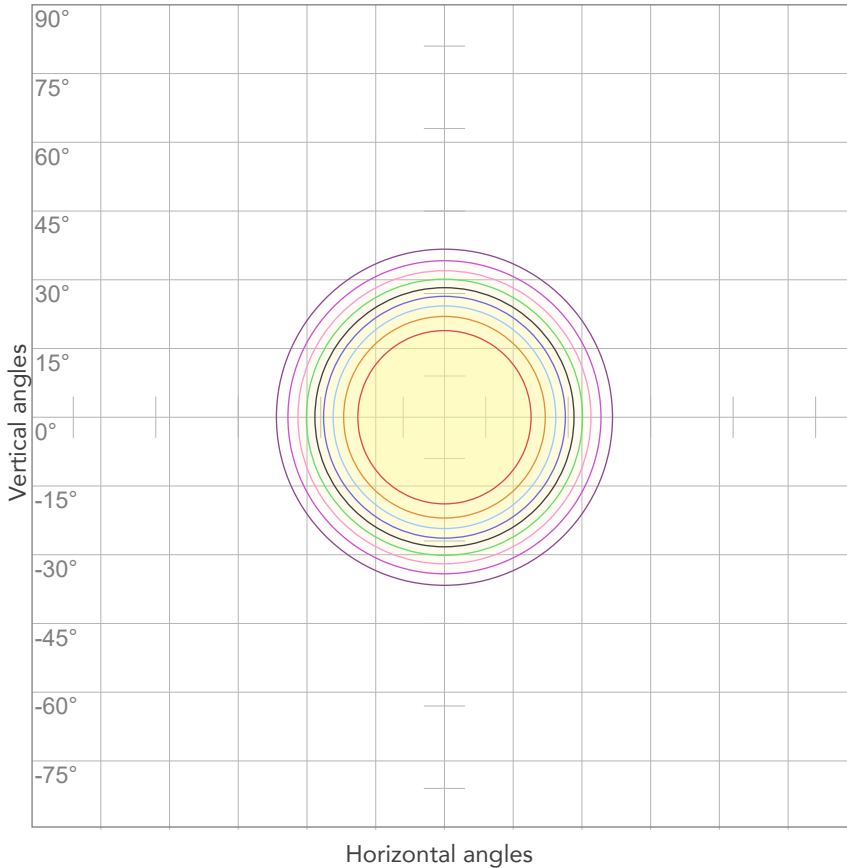

10%	42 cd
20%	83 cd
30%	125 cd
40%	167 cd
50%	208 cd
60%	250 cd
70%	291 cd
80%	333 cd

Conditions:

Number of c-planes: 2  
Candela at center: 416 cd

## ISO LUX DIAGRAM

MH: 10,0 m

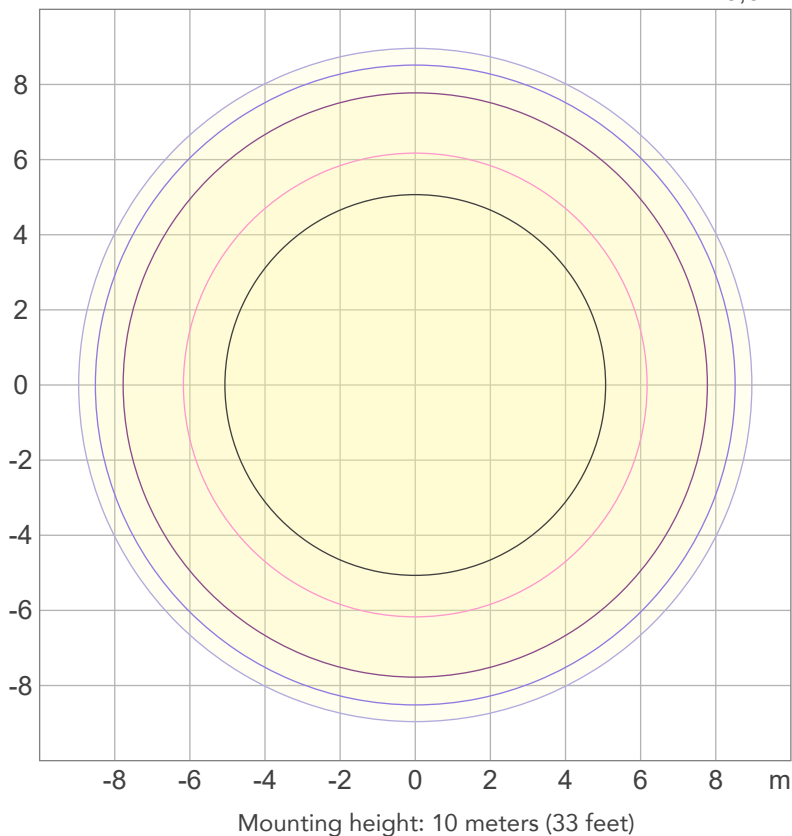

3%	0,125 lx
5%	0,208 lx
10%	0,416 lx
30%	1,25 lx
50%	2,08 lx

Conditions:

Number of c-planes: 2  
Lux at center: 4,16 lx

*Lux distribution on a surface when lamp is mounted at 10 meters from the surface.*



Total lumen output:

296 lm

Peak candela output:

1476 cd

PRODUCT NAME:

ECLFRCTPM

MEASURAMENT CONDITIONS:

Beam angle:

Med Zoom

Target:

Cyan - HB

Operator:

Salvatore Giglio

Date and time:

03/10/2023 12:16:06

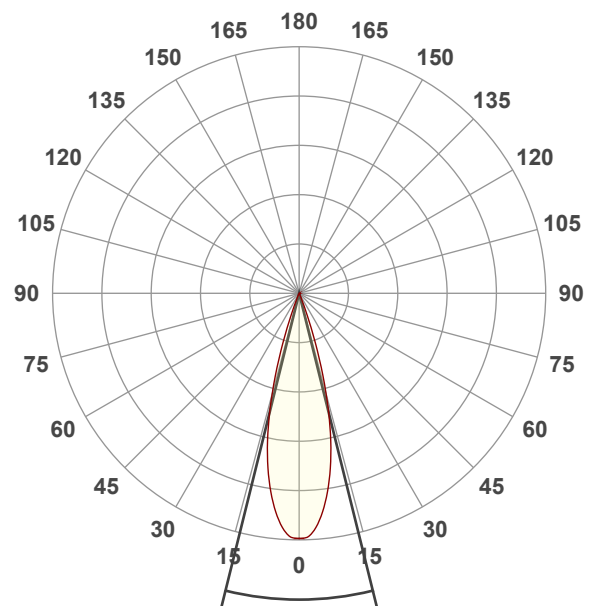

Beam angle 50%: 27,8°

Field angle 10%: 40,1°

Cut off angle 2.5%: 45,3°

Spectra

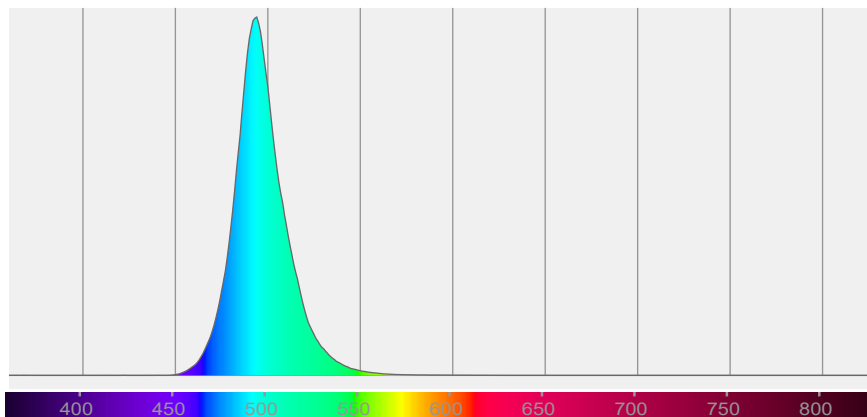

# BEAM DETAILS



Beam angle 50%	Field angle 10%	Cut off angle 2,5%	Intensity ratio in 120° cone	Intensity ratio in 90° cone
27,8°	40,1°	45,3°	100,0%	100,0%

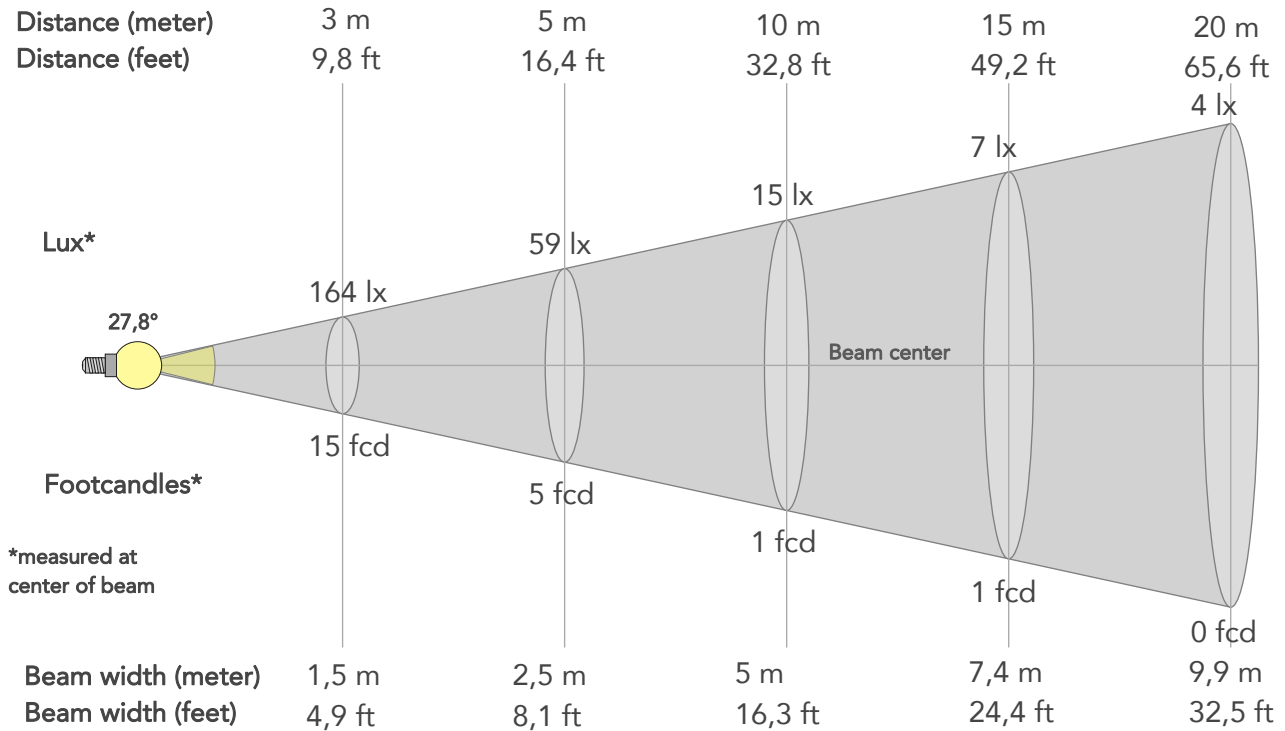

## BEAM INTENSITIES AND WIDTHS

Distance	1m	2m	3m	4m	5m	7,5m	10m	15m	20m	25m	30m	40m	50m
Distance	3,3ft	6,6ft	9,8ft	13,1ft	16,4ft	24,6ft	32,8ft	49,2ft	65,6ft	82ft	98,4ft	131,2ft	164ft
Lux	1476lx	369lx	164lx	92lx	59lx	26lx	15lx	7lx	4lx	2lx	2lx	1lx	1lx
Footcand.	137fcd	34fcd	15fcd	9fcd	5fcd	2fcd	1fcd	1fcd	0fcd	0fcd	0fcd	0fcd	0fcd
Beam wid.	0,5m	1m	1,5m	2m	2,5m	3,7m	5m	7,4m	9,9m	12,4m	14,9m	19,8m	24,8m
Beam wid.	1,6ft	3,3ft	4,9ft	6,5ft	8,1ft	12,2ft	16,3ft	24,4ft	32,5ft	40,6ft	48,8ft	65ft	81,3ft

## LINEAR DISTRIBUTION DIAGRAM

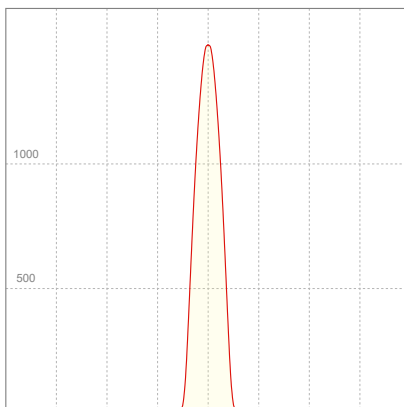

## ELECTRICAL SPECIFICATIONS

Input voltage	Input current	Input power	Effeciency
230V	0,312A	28,6W	10lm/W

Power FC
0,4

## ISO CANDELA DIAGRAM

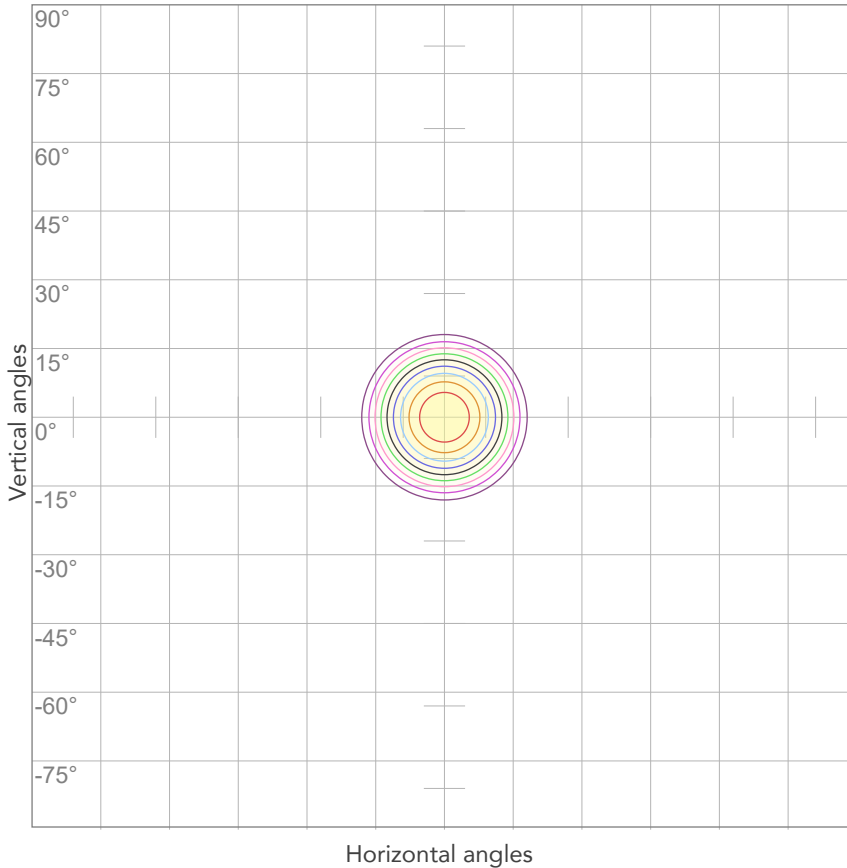

10%	148 cd
20%	295 cd
30%	443 cd
40%	590 cd
50%	738 cd
60%	886 cd
70%	1033 cd
80%	1181 cd

Conditions:

Number of c-planes: 2

Candela at center: 1476 cd

## ISO LUX DIAGRAM

MH: 10,0 m

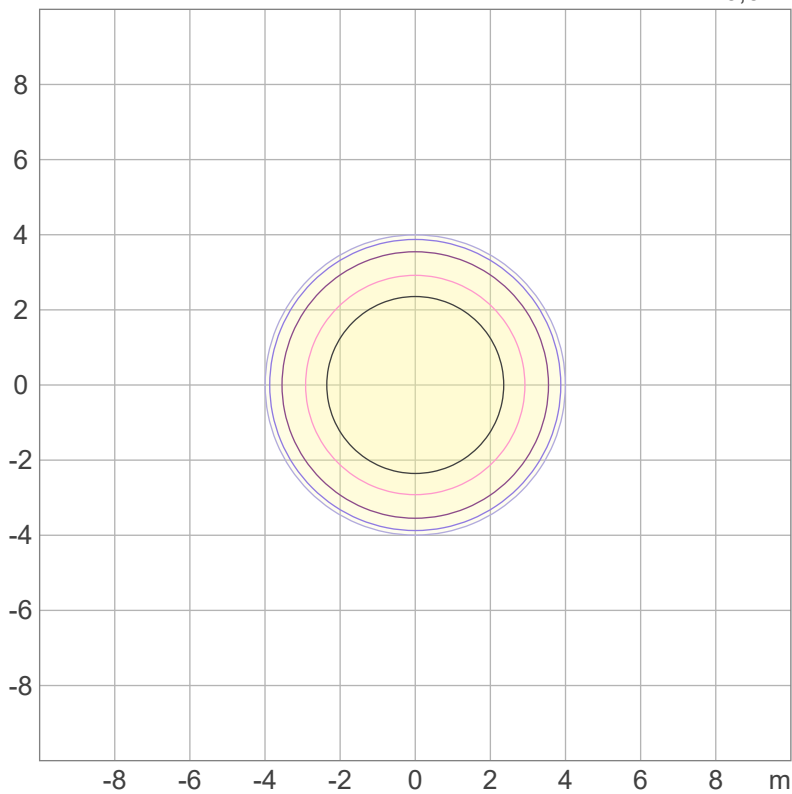

3%	0,443 lx
5%	0,738 lx
10%	1,48 lx
30%	4,43 lx
50%	7,38 lx

Conditions:

Number of c-planes: 2

Lux at center: 14,8 lx

*Lux distribution on a surface when lamp is mounted at 10 meters from the surface.*



Total lumen output:

155 lm

Peak candela output:

5374 cd

PRODUCT NAME:

ECLFRCTPM

MEASURAMENT CONDITIONS:

Beam angle:

Min Zoom

Target:

Cyan - HB

Operator:

Salvatore Giglio

Date and time:

03/10/2023 11:04:30

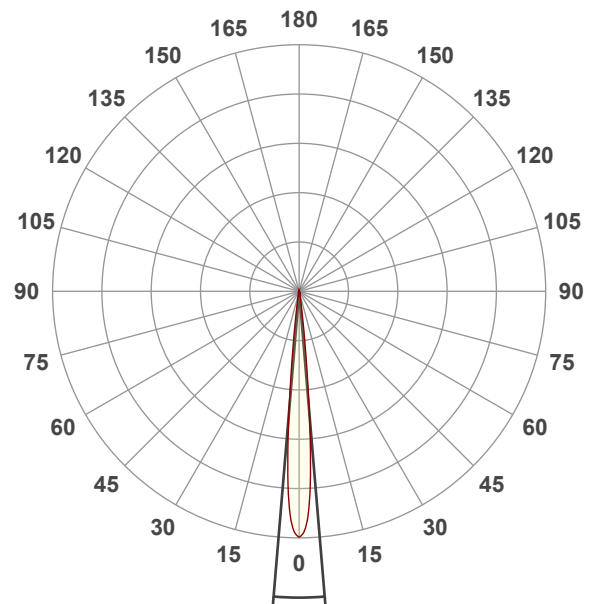

Beam angle 50%: 9,6°

Field angle 10%: 15,4°

Cut off angle 2.5%: 20,2°

Spectra

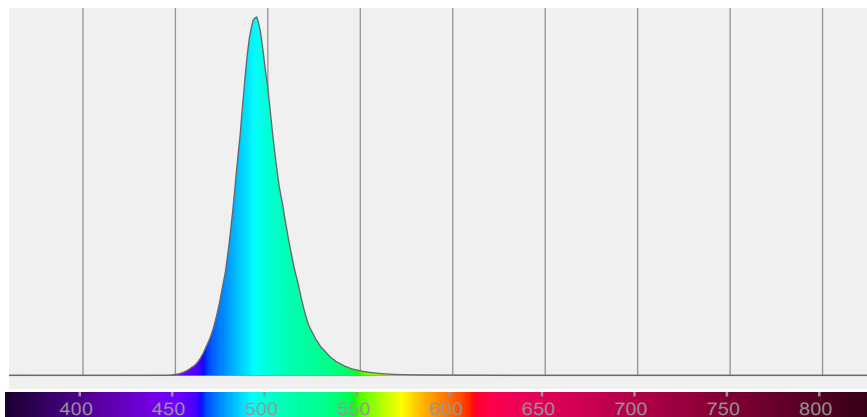

# BEAM DETAILS



Beam angle 50%	Field angle 10%	Cut off angle 2,5%	Intensity ratio in 120° cone	Intensity ratio in 90° cone
9,6°	15,4°	20,2°	100,0%	100,0%

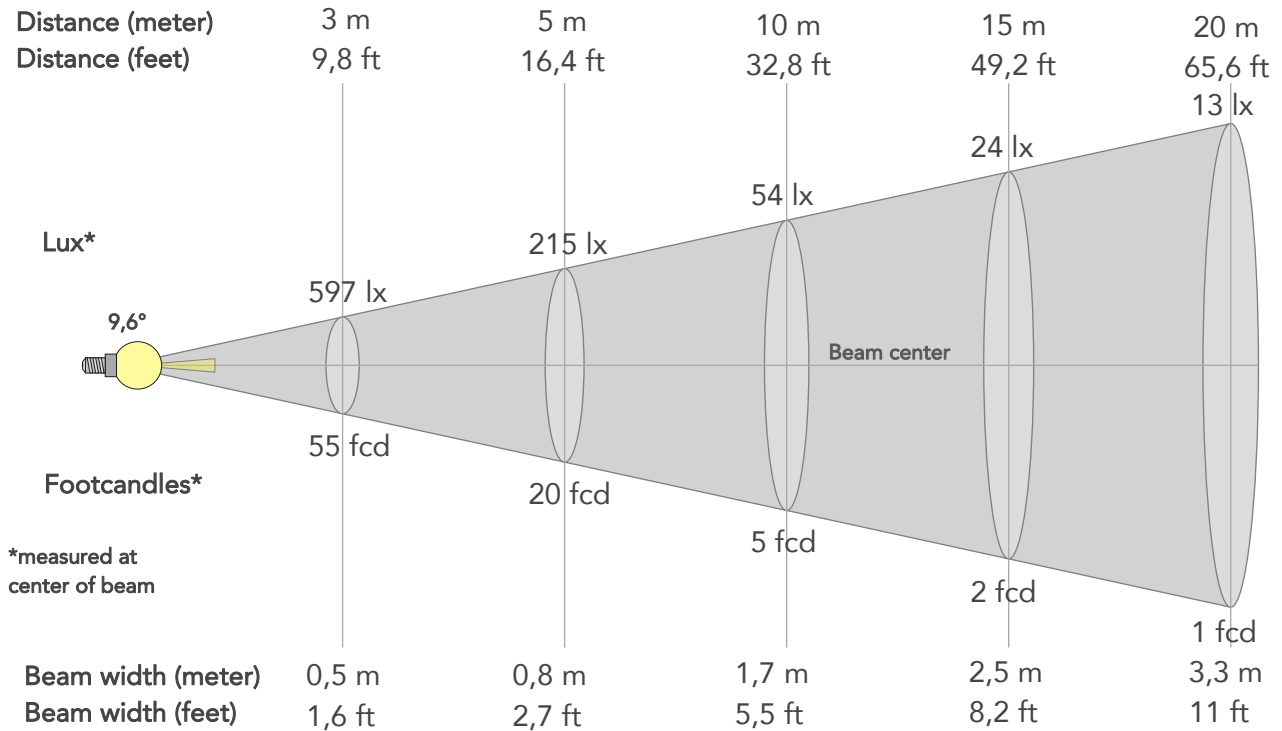

## BEAM INTENSITIES AND WIDTHS

Distance	1m	2m	3m	4m	5m	7,5m	10m	15m	20m	25m	30m	40m	50m
Distance	3,3ft	6,6ft	9,8ft	13,1ft	16,4ft	24,6ft	32,8ft	49,2ft	65,6ft	82ft	98,4ft	131,2ft	164ft
Lux	5374lx	1344lx	597lx	336lx	215lx	96lx	54lx	24lx	13lx	9lx	6lx	3lx	2lx
Footcand.	499fcd	125fcd	55fcd	31fcd	20fcd	9fcd	5fcd	2fcd	1fcd	1fcd	1fcd	0fcd	0fcd
Beam wid.	0,2m	0,3m	0,5m	0,7m	0,8m	1,3m	1,7m	2,5m	3,3m	4,2m	5m	6,7m	8,4m
Beam wid.	0,6ft	1,1ft	1,6ft	2,2ft	2,7ft	4,1ft	5,5ft	8,2ft	11ft	13,7ft	16,5ft	22ft	27,4ft

## LINEAR DISTRIBUTION DIAGRAM

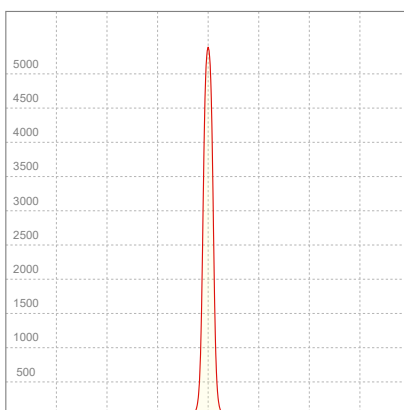

## ELECTRICAL SPECIFICATIONS

Input voltage	Input current	Input power	Effeciency
229V	0,313A	28,6W	5lm/W

Power FC
0,4



## ISO CANDELA DIAGRAM

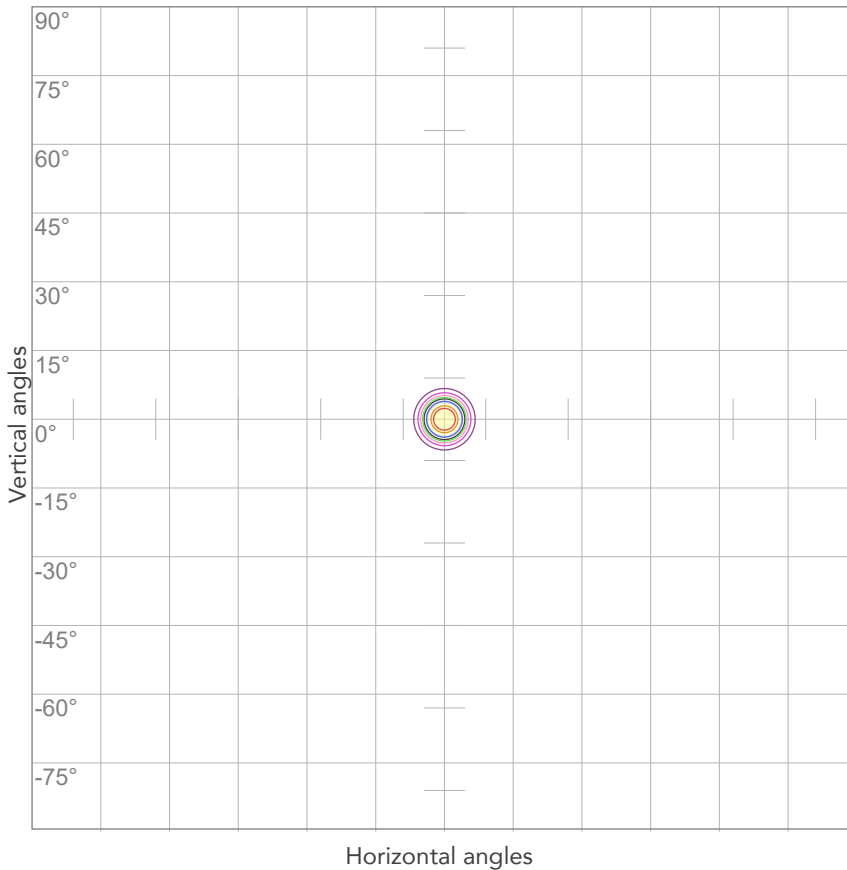

10%	537 cd
20%	1075 cd
30%	1612 cd
40%	2150 cd
50%	2687 cd
60%	3225 cd
70%	3762 cd
80%	4299 cd

Conditions:

Number of c-planes: 2

Candela at center: 5374 cd

## ISO LUX DIAGRAM

MH: 10,0 m

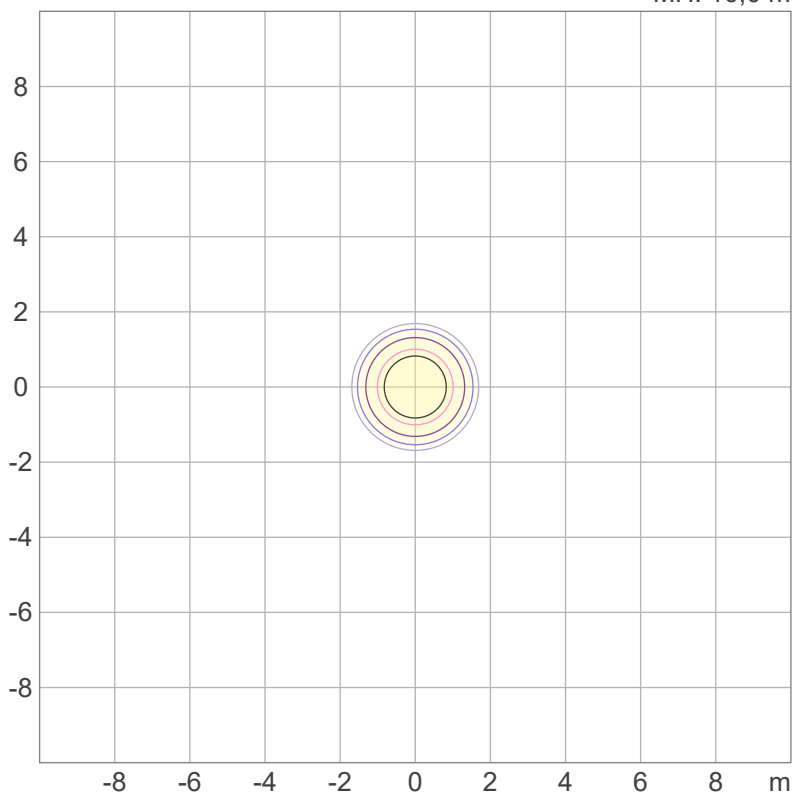

3%	1,61 lx
5%	2,69 lx
10%	5,37 lx
30%	16,1 lx
50%	26,9 lx

Conditions:

Number of c-planes: 2

Lux at center: 53,7 lx

*Lux distribution on a surface when lamp is mounted at 10 meters from the surface.*



Total lumen output:

4940 lm

Peak candela output:

5715 cd

PRODUCT NAME:

ECLFRCTPM

MEASURAMENT CONDITIONS:

Beam angle:

Max Zoom

Target:

Mint - HB

Operator:

Salvatore Giglio

Date and time:

03/10/2023 10:55:57

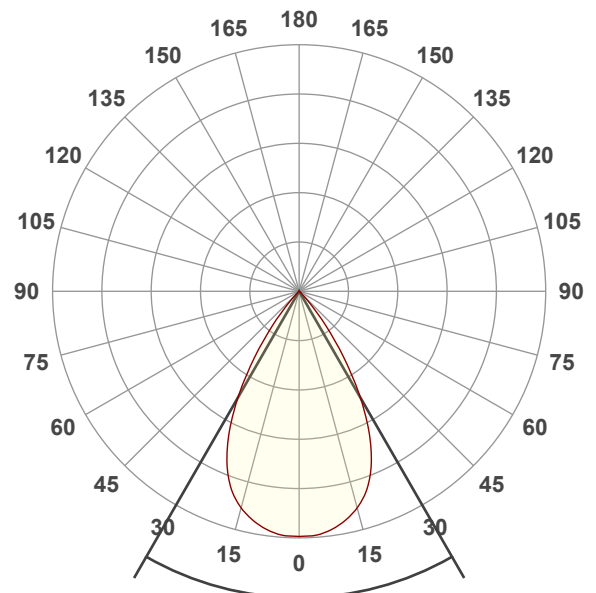

Beam angle 50%: 59,9°

Field angle 10%: 81,1°

Cut off angle 2.5%: 89,2°

Spectra

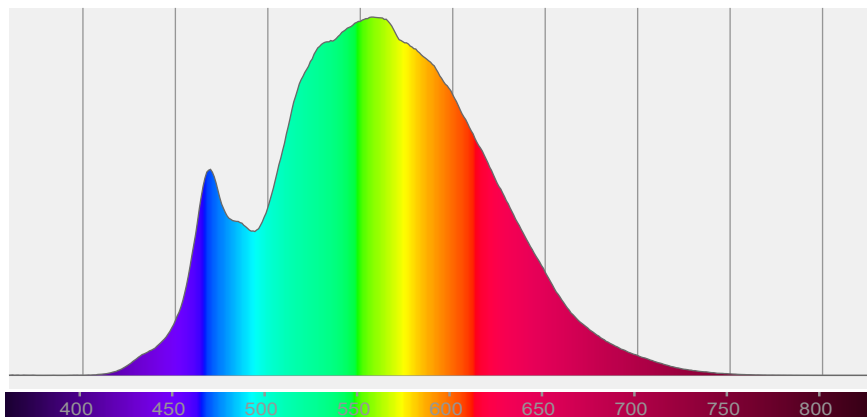

# BEAM DETAILS



Beam angle 50%	Field angle 10%	Cut off angle 2,5%	Intensity ratio in 120° cone	Intensity ratio in 90° cone
59,9°	81,1°	89,2°	99,9%	99,4%

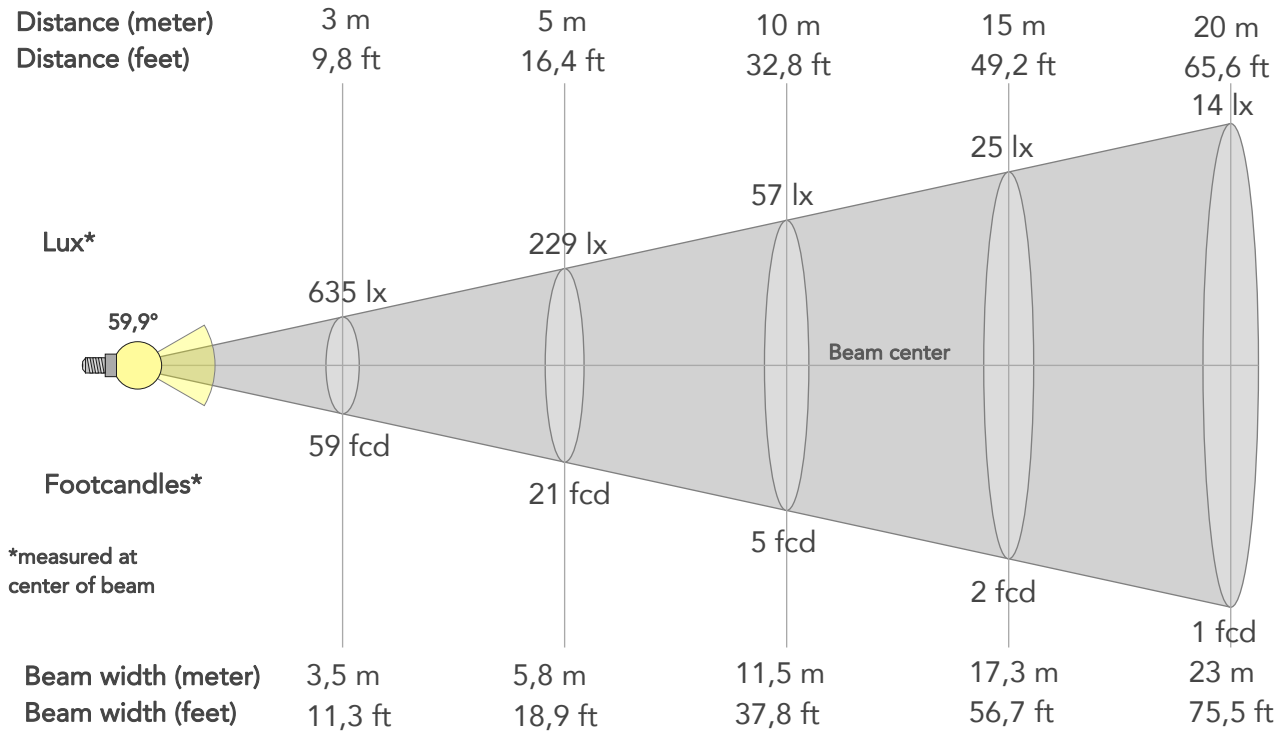

## BEAM INTENSITIES AND WIDTHS

Distance	1m	2m	3m	4m	5m	7,5m	10m	15m	20m	25m	30m	40m	50m
Distance	3,3ft	6,6ft	9,8ft	13,1ft	16,4ft	24,6ft	32,8ft	49,2ft	65,6ft	82ft	98,4ft	131,2ft	164ft
Lux	5715lx	1429lx	635lx	357lx	229lx	102lx	57lx	25lx	14lx	9lx	6lx	4lx	2lx
Footcand.	531fcd	133fcd	59fcd	33fcd	21fcd	9fcd	5fcd	2fcd	1fcd	1fcd	1fcd	0fcd	0fcd
Beam wid.	1,2m	2,3m	3,5m	4,6m	5,8m	8,6m	11,5m	17,3m	23m	28,8m	34,5m	46,1m	57,6m
Beam wid.	3,8ft	7,6ft	11,3ft	15,1ft	18,9ft	28,3ft	37,8ft	56,7ft	75,5ft	94,4ft	113,3ft	151,1ft	188,9ft

## LINEAR DISTRIBUTION DIAGRAM

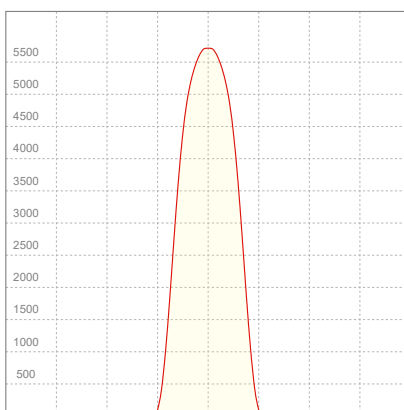

## ELECTRICAL SPECIFICATIONS

Input voltage	Input current	Input power	Effeciency
229V	0,514A	105,4W	47lm/W

Power FC
0,89

## ISO CANDELA DIAGRAM

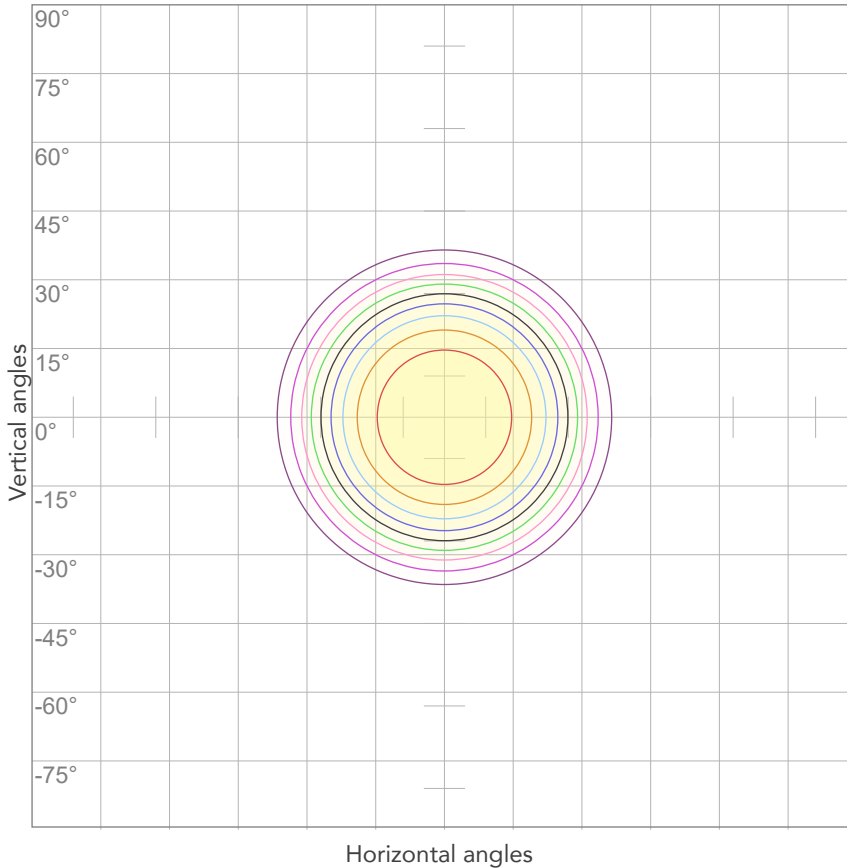

10%	572 cd
20%	1143 cd
30%	1715 cd
40%	2286 cd
50%	2858 cd
60%	3429 cd
70%	4001 cd
80%	4572 cd

Conditions:

Number of c-planes: 2

Candela at center: 5715 cd

## ISO LUX DIAGRAM

MH: 10,0 m

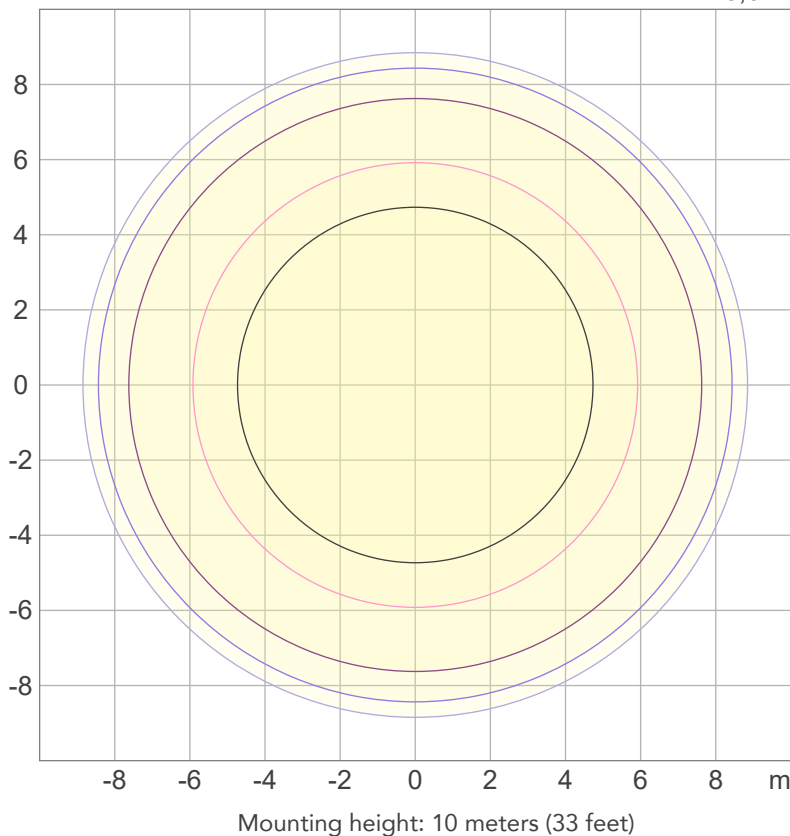

3%	1,71 lx
5%	2,86 lx
10%	5,72 lx
30%	17,1 lx
50%	28,6 lx

Conditions:

Number of c-planes: 2

Lux at center: 57,2 lx

*Lux distribution on a surface when lamp is mounted at 10 meters from the surface.*



Total lumen output:

3776 lm

Peak candela output:

19789 cd

**PRODUCT NAME:**

ECLFRCTPM

**MEASURAMENT CONDITIONS:**

Beam angle:

Med Zoom

Target:

Mint - HB

Operator:

Salvatore Giglio

Date and time:

03/10/2023 12:19:30

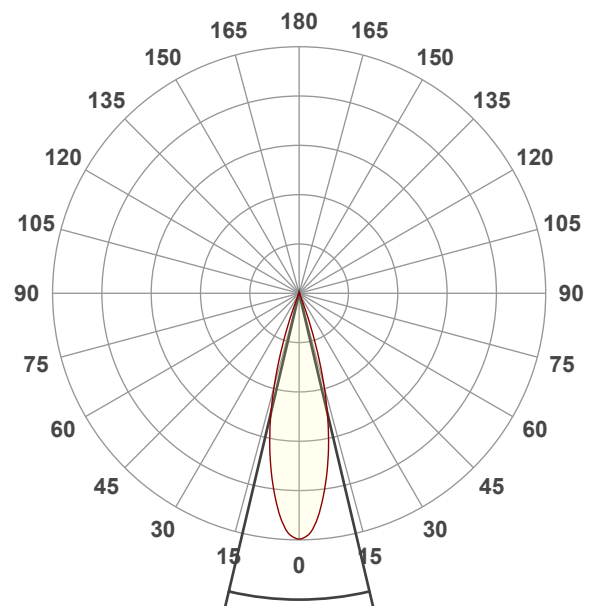

Beam angle 50%: 26,6°

Field angle 10%: 40,3°

Cut off angle 2.5%: 45,4°

Spectra

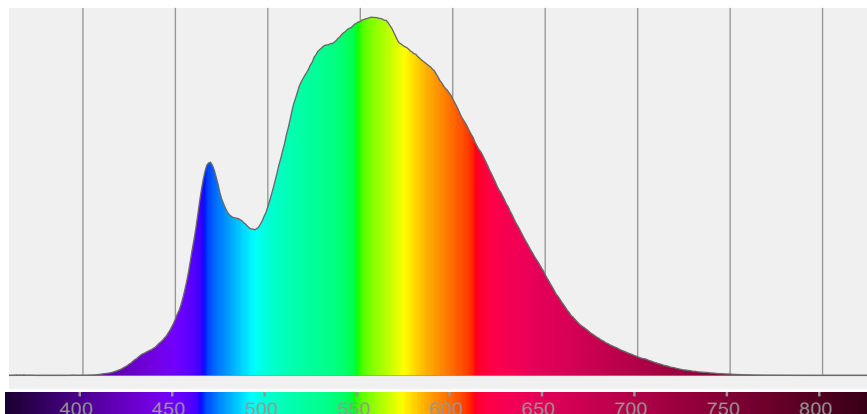

# BEAM DETAILS



Beam angle 50%	Field angle 10%	Cut off angle 2,5%	Intensity ratio in 120° cone	Intensity ratio in 90° cone
26,6°	40,3°	45,4°	100,0%	99,9%

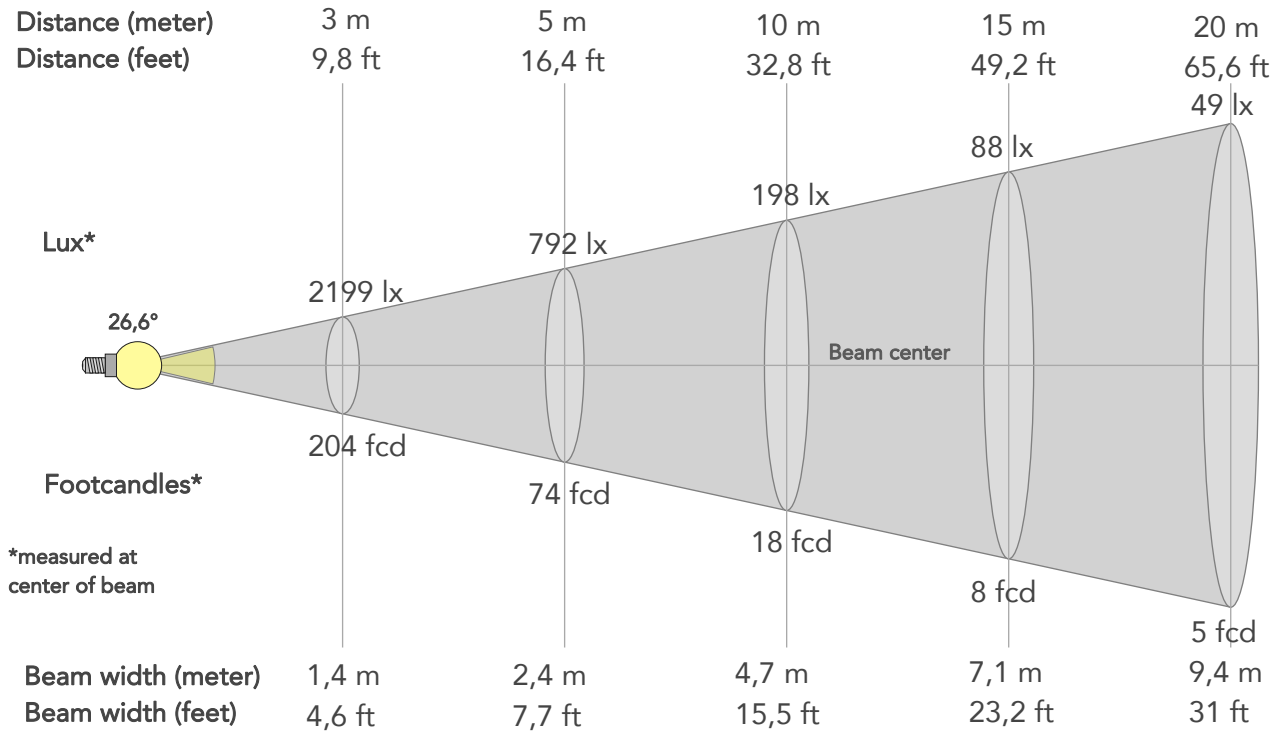

## BEAM INTENSITIES AND WIDTHS

Distance	1m	2m	3m	4m	5m	7,5m	10m	15m	20m	25m	30m	40m	50m
Distance	3,3ft	6,6ft	9,8ft	13,1ft	16,4ft	24,6ft	32,8ft	49,2ft	65,6ft	82ft	98,4ft	131,2ft	164ft
Lux	19789lx	4947lx	2199lx	1237lx	792lx	352lx	198lx	88lx	49lx	32lx	22lx	12lx	8lx
Footcand.	1838fcd	460fcd	204fcd	115fcd	74fcd	33fcd	18fcd	8fcd	5fcd	3fcd	2fcd	1fcd	1fcd
Beam wid.	0,5m	0,9m	1,4m	1,9m	2,4m	3,5m	4,7m	7,1m	9,4m	11,8m	14,2m	18,9m	23,6m
Beam wid.	1,6ft	3,1ft	4,6ft	6,2ft	7,7ft	11,6ft	15,5ft	23,2ft	31ft	38,7ft	46,4ft	61,9ft	77,4ft

## LINEAR DISTRIBUTION DIAGRAM

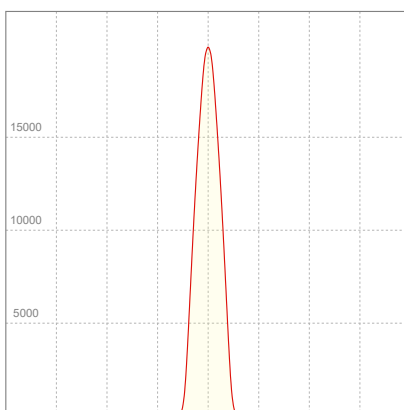

## ELECTRICAL SPECIFICATIONS

Input voltage	Input current	Input power	Effeciency
229V	0,513A	105,6W	36lm/W
Power FC			
0,9			

## ISO CANDELA DIAGRAM

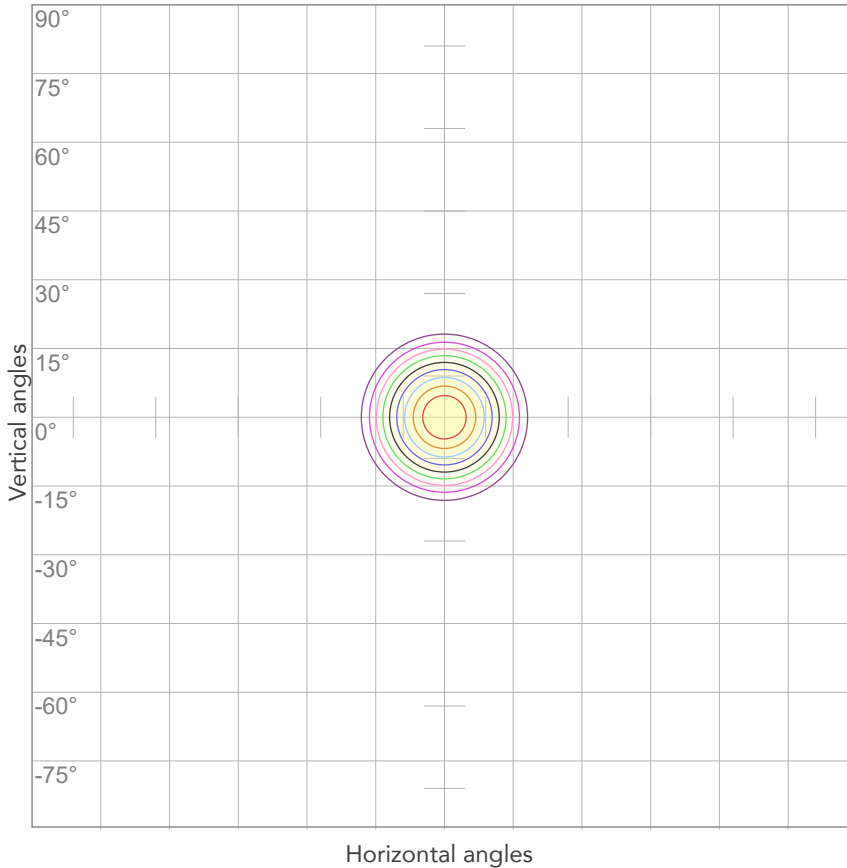

10%	1979 cd
20%	3958 cd
30%	5937 cd
40%	7916 cd
50%	9894 cd
60%	11873 cd
70%	13852 cd
80%	15831 cd

Conditions:

Number of c-planes: 2

Candela at center: 19789 cd

## ISO LUX DIAGRAM

MH: 10,0 m

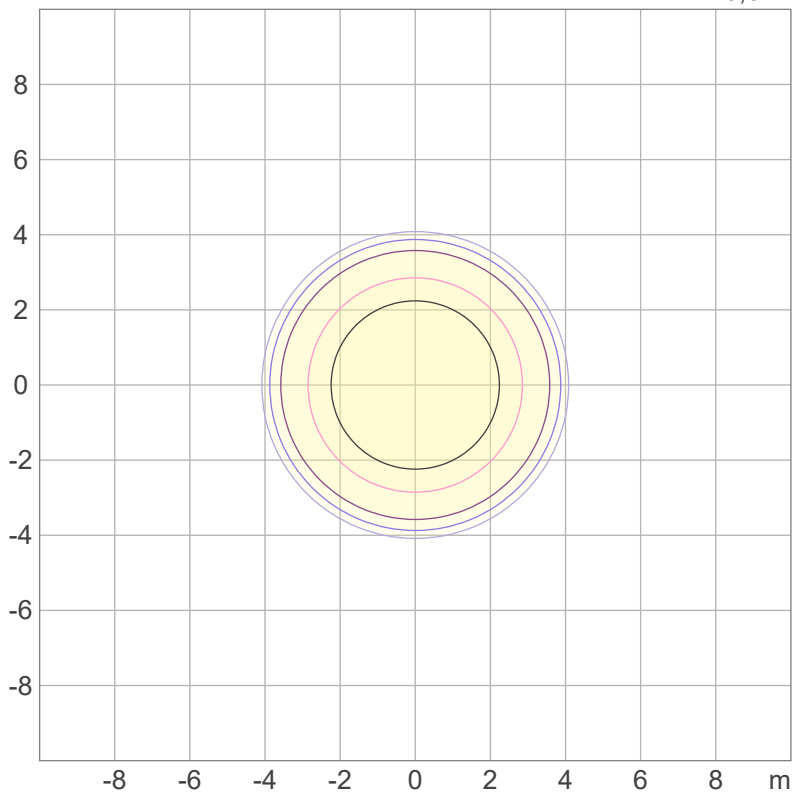

3%	5,94 lx
5%	9,89 lx
10%	19,8 lx
30%	59,4 lx
50%	98,9 lx

Conditions:

Number of c-planes: 2

Lux at center: 198 lx

*Lux distribution on a surface when lamp is mounted at 10 meters from the surface.*



Total lumen output:

1986 lm

Peak candela output:

72173 cd

**PRODUCT NAME:**

ECLFRCTPM

**MEASURAMENT CONDITIONS:**

Beam angle:

Min Zoom

Target:

Mint - HB

Operator:

Salvatore Giglio

Date and time:

03/10/2023 11:06:11

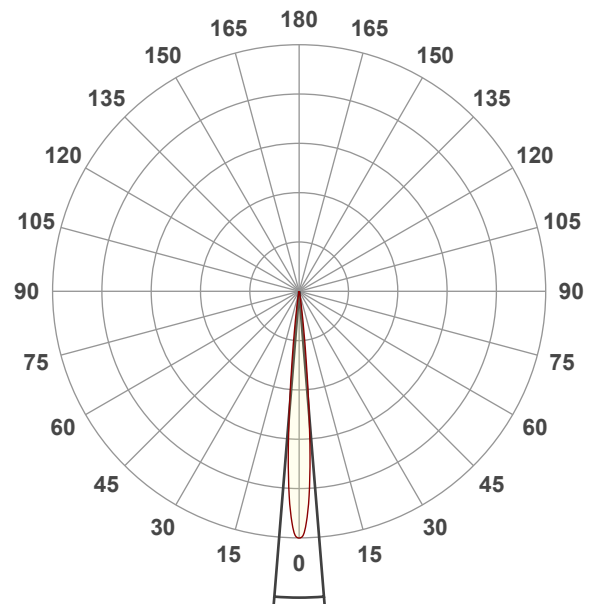

Beam angle 50%: 9,3°

Field angle 10%: 15,3°

Cut off angle 2.5%: 20,3°

Spectra

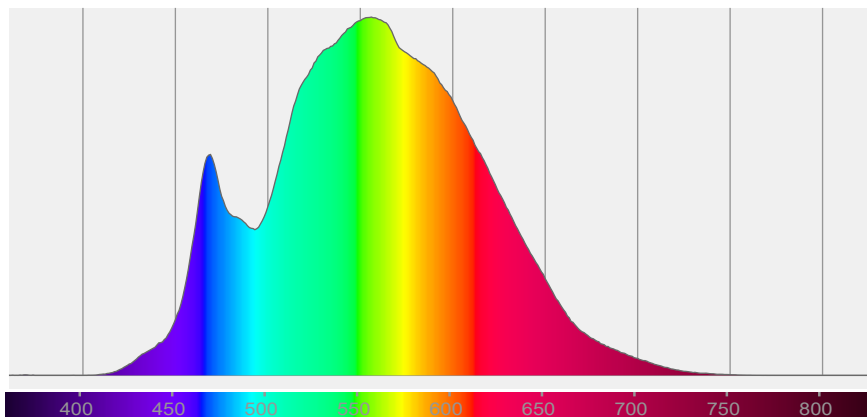



# BEAM DETAILS



Beam angle 50%	Field angle 10%	Cut off angle 2,5%	Intensity ratio in 120° cone	Intensity ratio in 90° cone
9,3°	15,3°	20,3°	100,0%	100,0%

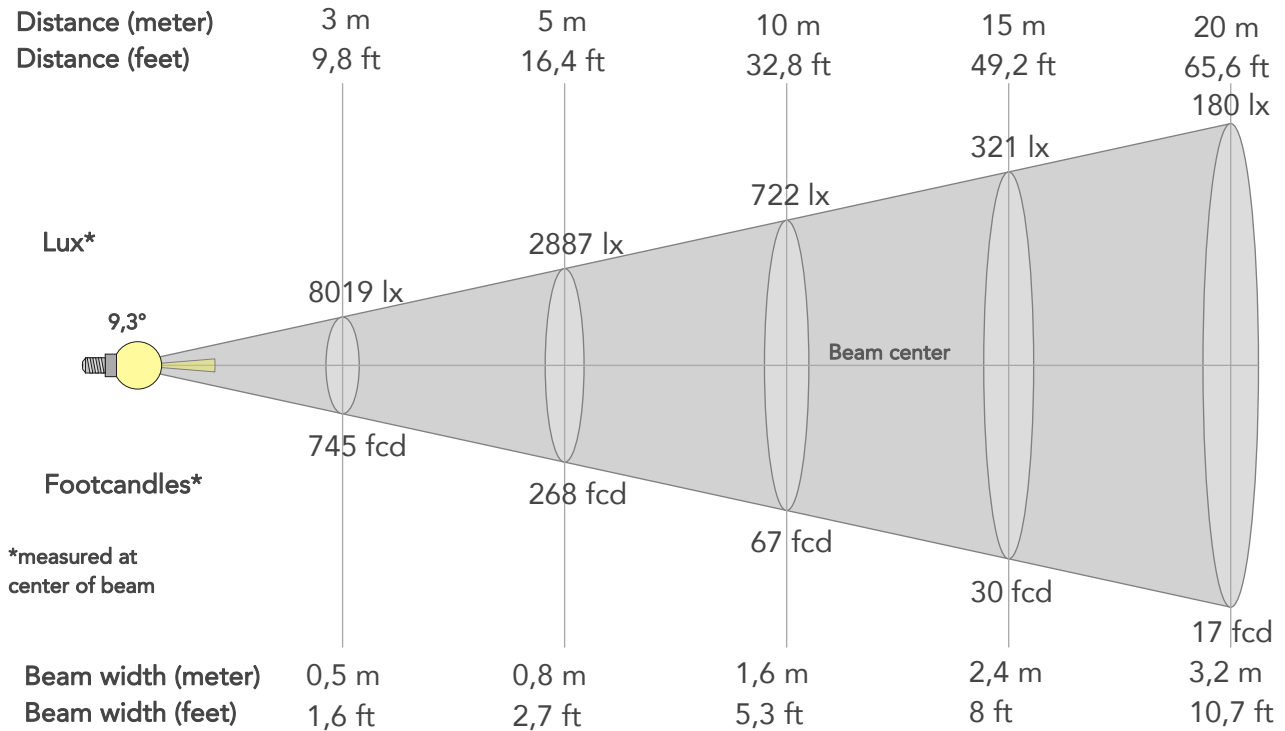

## BEAM INTENSITIES AND WIDTHS

Distance	1m	2m	3m	4m	5m	7,5m	10m	15m	20m	25m	30m	40m	50m
Distance	3,3ft	6,6ft	9,8ft	13,1ft	16,4ft	24,6ft	32,8ft	49,2ft	65,6ft	82ft	98,4ft	131,2ft	164ft
Lux	72172lx	18043lx	8019lx	4511lx	2887lx	1283lx	722lx	321lx	180lx	115lx	80lx	45lx	29lx
Footcand.	6705fcd	1676fcd	745fcd	419fcd	268fcd	119fcd	67fcd	30fcd	17fcd	11fcd	7fcd	4fcd	3fcd
Beam wid.	0,2m	0,3m	0,5m	0,6m	0,8m	1,2m	1,6m	2,4m	3,2m	4,1m	4,9m	6,5m	8,1m
Beam wid.	0,5ft	1,1ft	1,6ft	2,1ft	2,7ft	4ft	5,3ft	8ft	10,7ft	13,3ft	16ft	21,3ft	26,6ft

## LINEAR DISTRIBUTION DIAGRAM

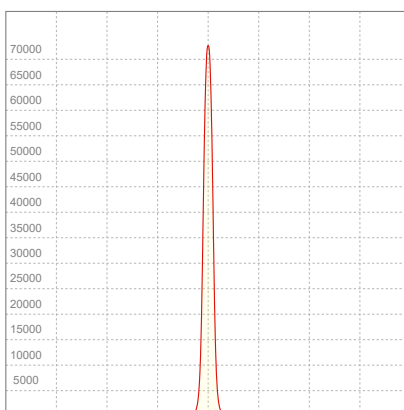

## ELECTRICAL SPECIFICATIONS

Input voltage	Input current	Input power	Effeciency
229V	0,514A	105,6W	19lm/W

Power FC
0,9

## ISO CANDELA DIAGRAM

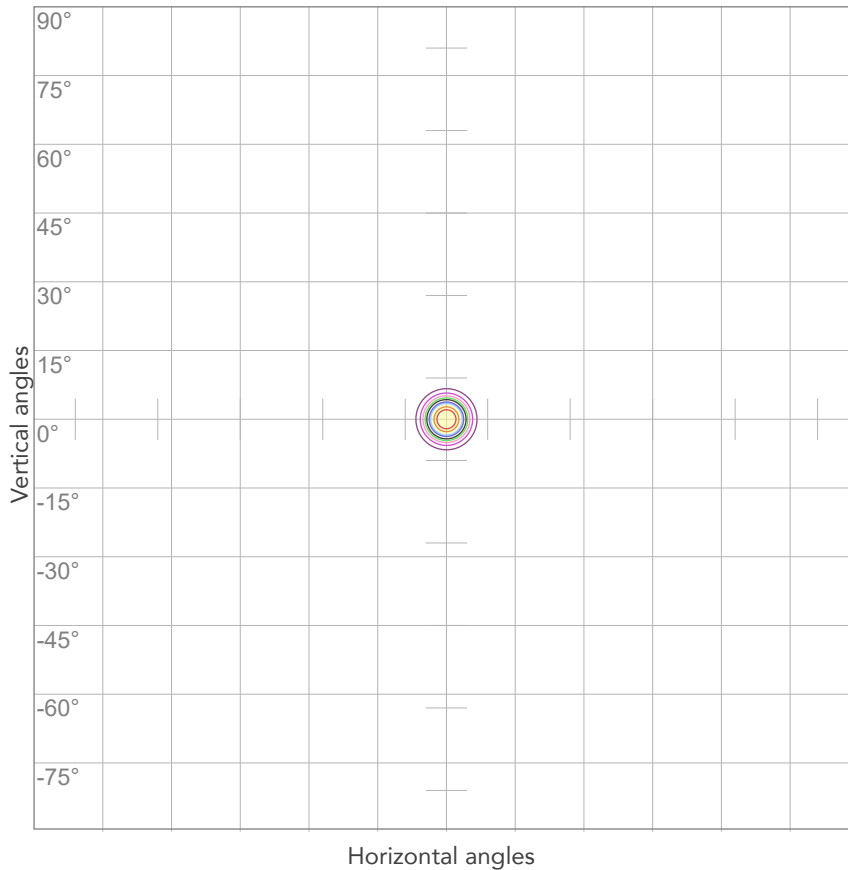

10%	7217 cd
20%	14434 cd
30%	21652 cd
40%	28869 cd
50%	36086 cd
60%	43303 cd
70%	50521 cd
80%	57738 cd

Conditions:

Number of c-planes: 2

Candela at center: 72172 cd

## ISO LUX DIAGRAM

MH: 10,0 m

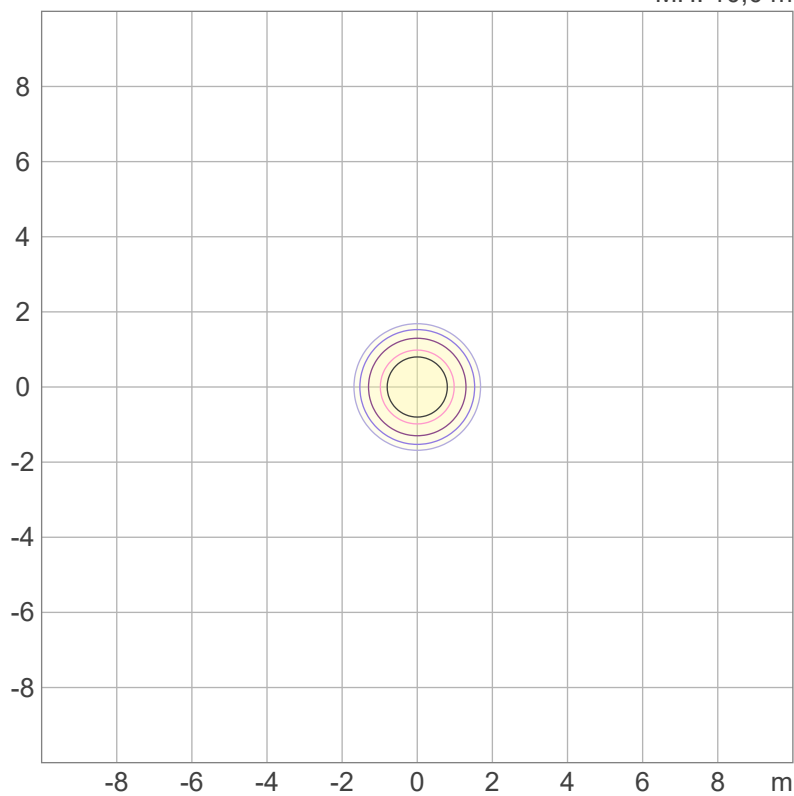

3%	21,7 lx
5%	36,1 lx
10%	72,2 lx
30%	217 lx
50%	361 lx

Conditions:

Number of c-planes: 2

Lux at center: 722 lx

*Lux distribution on a surface when lamp is mounted at 10 meters from the surface.*



Total lumen output:

2186 lm

Peak candela output:

2574 cd

PRODUCT NAME:

ECLFRCTPM

MEASURAMENT CONDITIONS:

Beam angle:

Max Zoom

Target:

Amber - HB

Operator:

Salvatore Giglio

Date and time:

03/10/2023 10:57:31

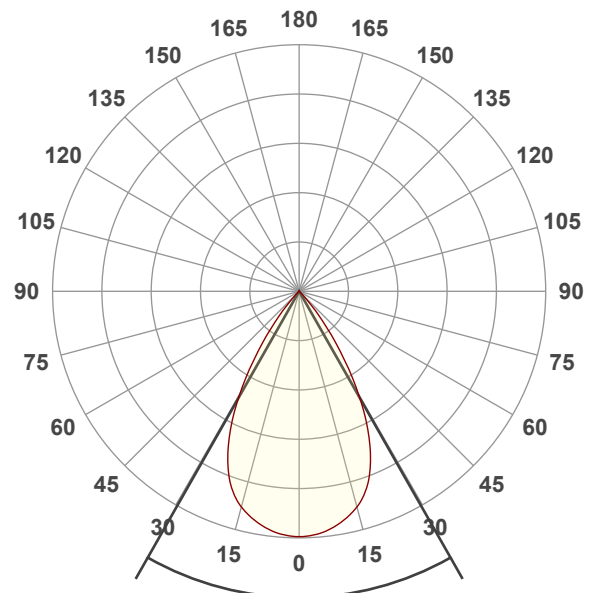

Beam angle 50%: 59,2°

Field angle 10%: 80,7°

Cut off angle 2.5%: 89,3°

Spectra

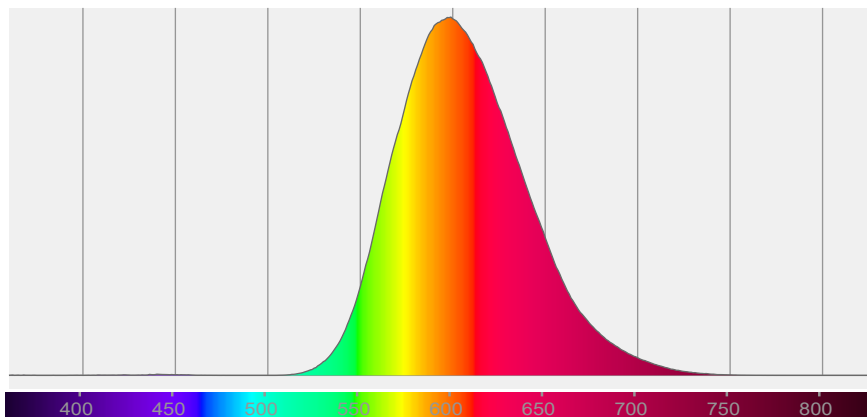

# BEAM DETAILS



Beam angle 50%	Field angle 10%	Cut off angle 2,5%	Intensity ratio in 120° cone	Intensity ratio in 90° cone
59,2°	80,7°	89,3°	100,0%	99,5%

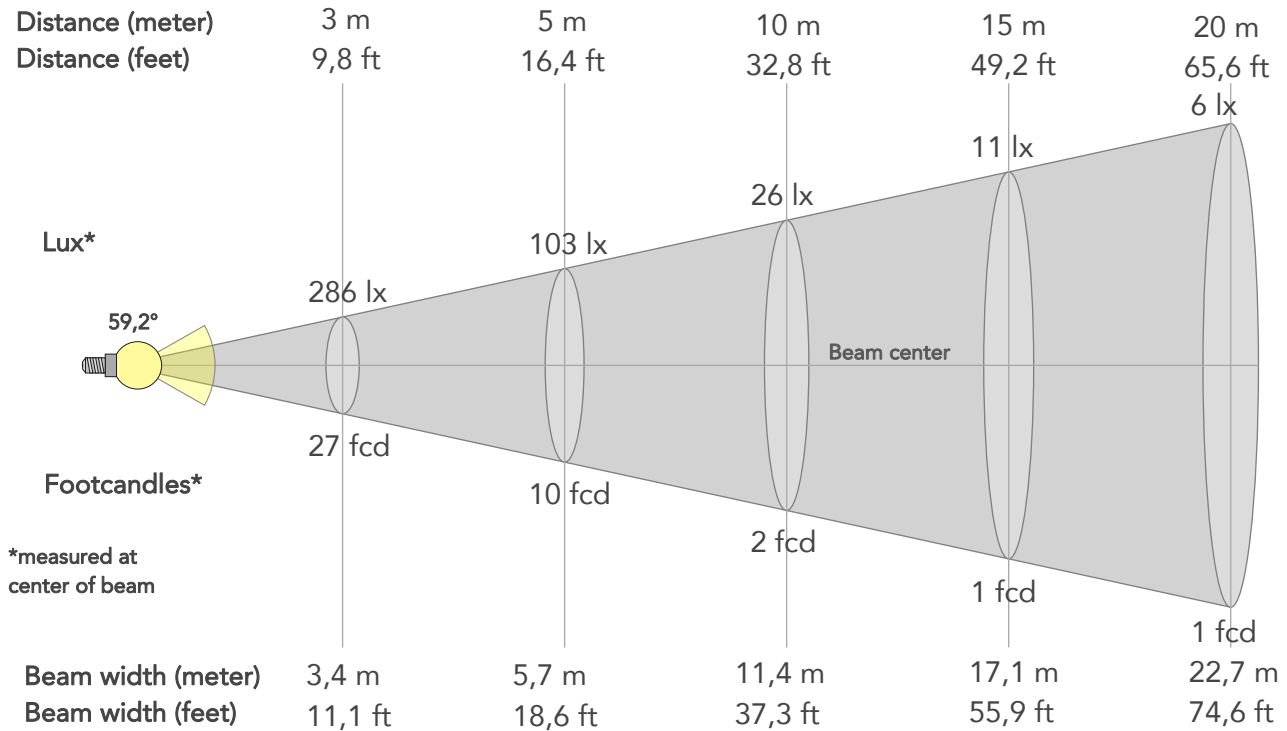

## BEAM INTENSITIES AND WIDTHS

Distance	1m	2m	3m	4m	5m	7,5m	10m	15m	20m	25m	30m	40m	50m
Distance	3,3ft	6,6ft	9,8ft	13,1ft	16,4ft	24,6ft	32,8ft	49,2ft	65,6ft	82ft	98,4ft	131,2ft	164ft
Lux	2574lx	644lx	286lx	161lx	103lx	46lx	26lx	11lx	6lx	4lx	3lx	2lx	1lx
Footcand.	239fcd	60fcd	27fcd	15fcd	10fcd	4fcd	2fcd	1fcd	1fcd	0fcd	0fcd	0fcd	0fcd
Beam wid.	1,1m	2,3m	3,4m	4,5m	5,7m	8,5m	11,4m	17,1m	22,7m	28,4m	34,1m	45,5m	56,8m
Beam wid.	3,8ft	7,5ft	11,1ft	14,9ft	18,6ft	28ft	37,3ft	55,9ft	74,6ft	93,2ft	111,9ft	149,2ft	186,5ft

## LINEAR DISTRIBUTION DIAGRAM

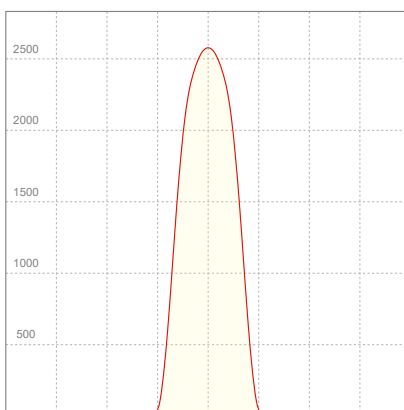

## ELECTRICAL SPECIFICATIONS

Input voltage	Input current	Input power	Effeciency
229V	0,458A	89,7W	24lm/W

Power FC
0,85

## ISO CANDELA DIAGRAM

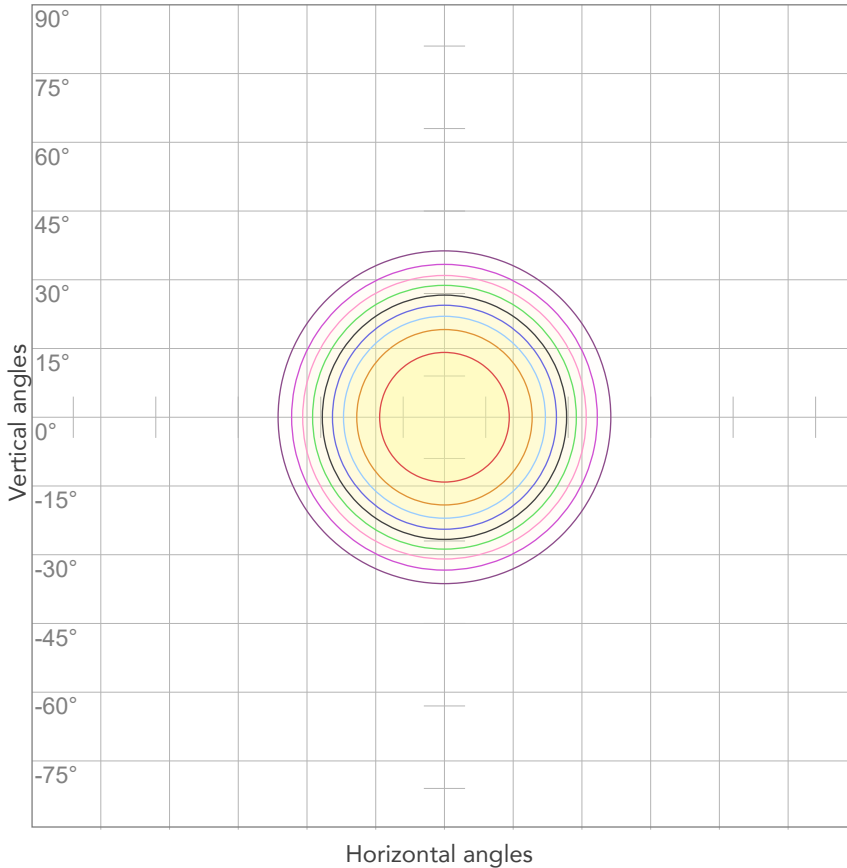

10%	257 cd
20%	515 cd
30%	772 cd
40%	1030 cd
50%	1287 cd
60%	1544 cd
70%	1802 cd
80%	2059 cd

Conditions:

Number of c-planes: 2

Candela at center: 2574 cd

## ISO LUX DIAGRAM

MH: 10,0 m

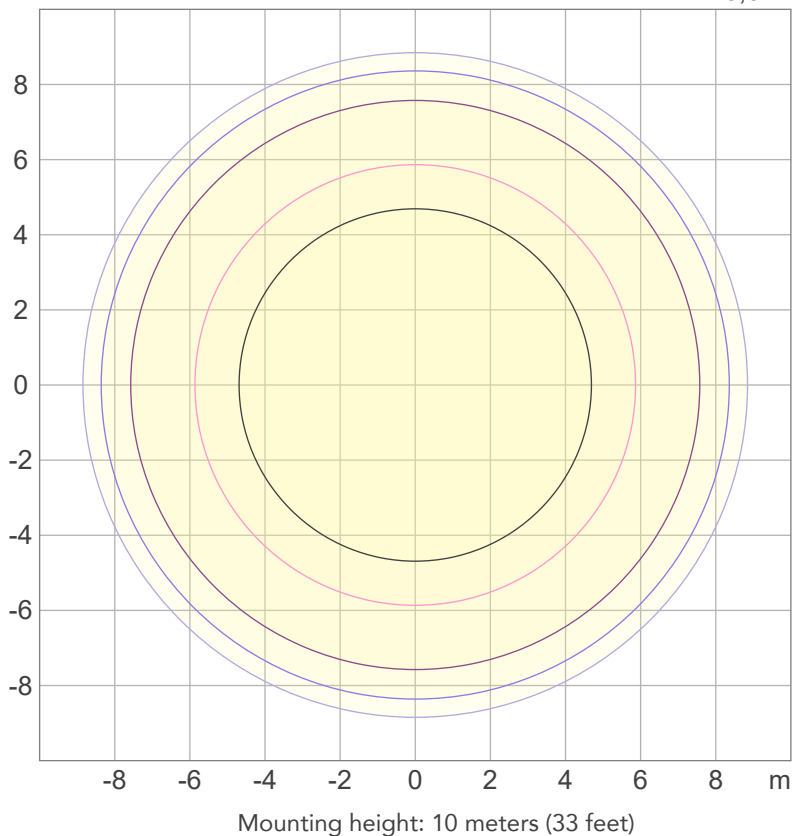

3%	0,772 lx
5%	1,29 lx
10%	2,57 lx
30%	7,72 lx
50%	12,9 lx

Conditions:

Number of c-planes: 2

Lux at center: 25,7 lx

*Lux distribution on a surface when lamp is mounted at 10 meters from the surface.*



Total lumen output:

1675 lm

Peak candela output:

8677 cd

PRODUCT NAME:

ECLFRCTPM

MEASURAMENT CONDITIONS:

Beam angle:

Med Zoom

Target:

Amber - HB

Operator:

Salvatore Giglio

Date and time:

03/10/2023 15:10:18

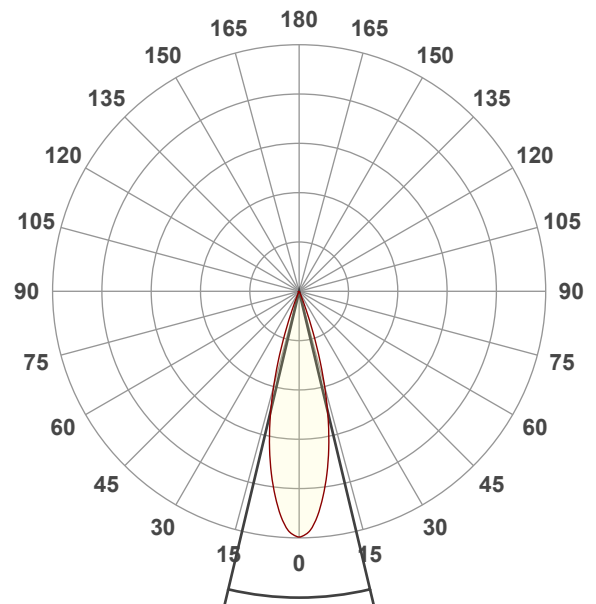

Beam angle 50%: 26,7°

Field angle 10%: 40,5°

Cut off angle 2.5%: 45,6°

Spectra

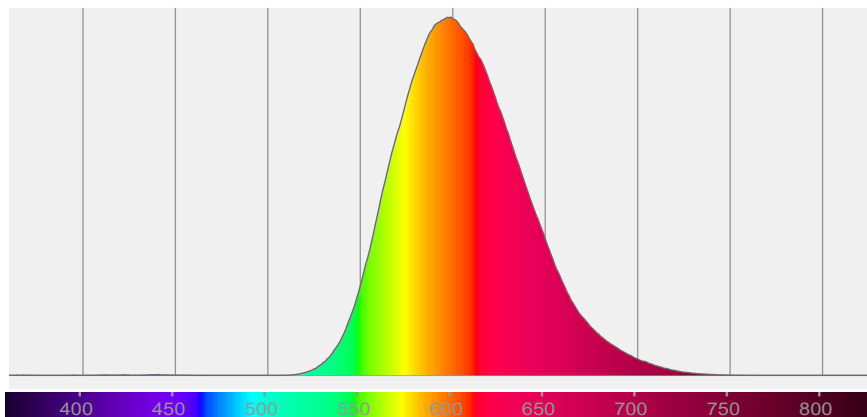

# BEAM DETAILS



Beam angle 50%	Field angle 10%	Cut off angle 2,5%	Intensity ratio in 120° cone	Intensity ratio in 90° cone
26,7°	40,5°	45,6°	100,0%	99,9%

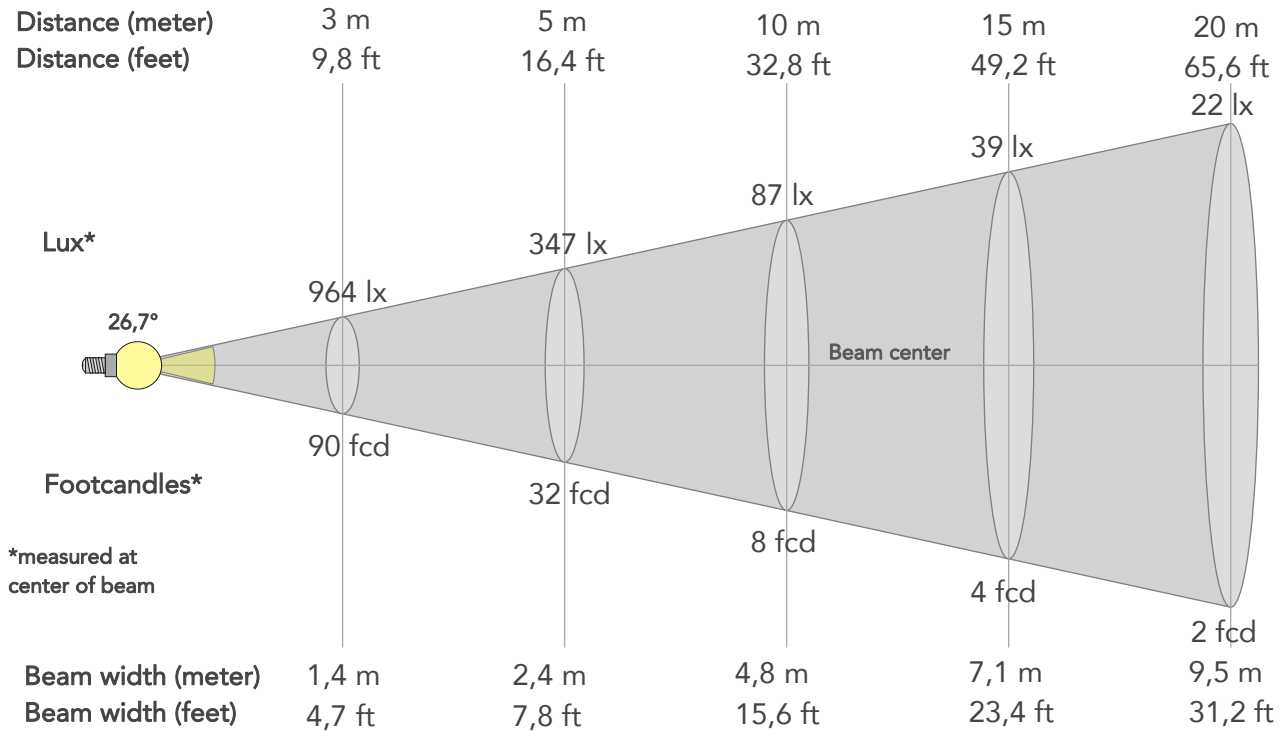

## BEAM INTENSITIES AND WIDTHS

Distance	1m	2m	3m	4m	5m	7,5m	10m	15m	20m	25m	30m	40m	50m
Distance	3,3ft	6,6ft	9,8ft	13,1ft	16,4ft	24,6ft	32,8ft	49,2ft	65,6ft	82ft	98,4ft	131,2ft	164ft
Lux	8677lx	2169lx	964lx	542lx	347lx	154lx	87lx	39lx	22lx	14lx	10lx	5lx	3lx
Footcand.	806fcd	202fcd	90fcd	50fcd	32fcd	14fcd	8fcd	4fcd	2fcd	1fcd	1fcd	1fcd	0fcd
Beam wid.	0,5m	1m	1,4m	1,9m	2,4m	3,6m	4,8m	7,1m	9,5m	11,9m	14,3m	19m	23,8m
Beam wid.	1,6ft	3,1ft	4,7ft	6,2ft	7,8ft	11,7ft	15,6ft	23,4ft	31,2ft	39ft	46,8ft	62,4ft	78ft

## LINEAR DISTRIBUTION DIAGRAM

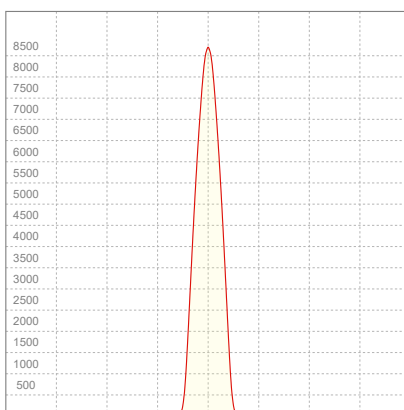

## ELECTRICAL SPECIFICATIONS

Input voltage	Input current	Input power	Effeciency
227V	0,457A	89,9W	19lm/W

Power FC
0,87

## ISO CANDELA DIAGRAM

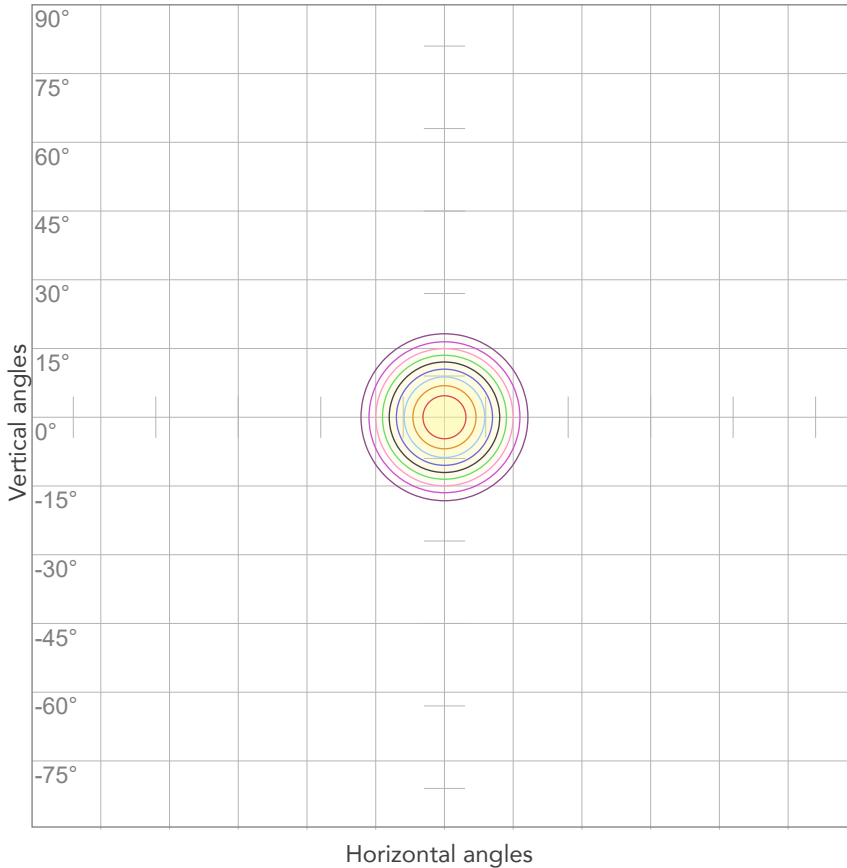

10%	868 cd
20%	1735 cd
30%	2603 cd
40%	3471 cd
50%	4338 cd
60%	5206 cd
70%	6074 cd
80%	6941 cd

Conditions:

Number of c-planes: 2

Candela at center: 8677 cd

## ISO LUX DIAGRAM

MH: 10,0 m

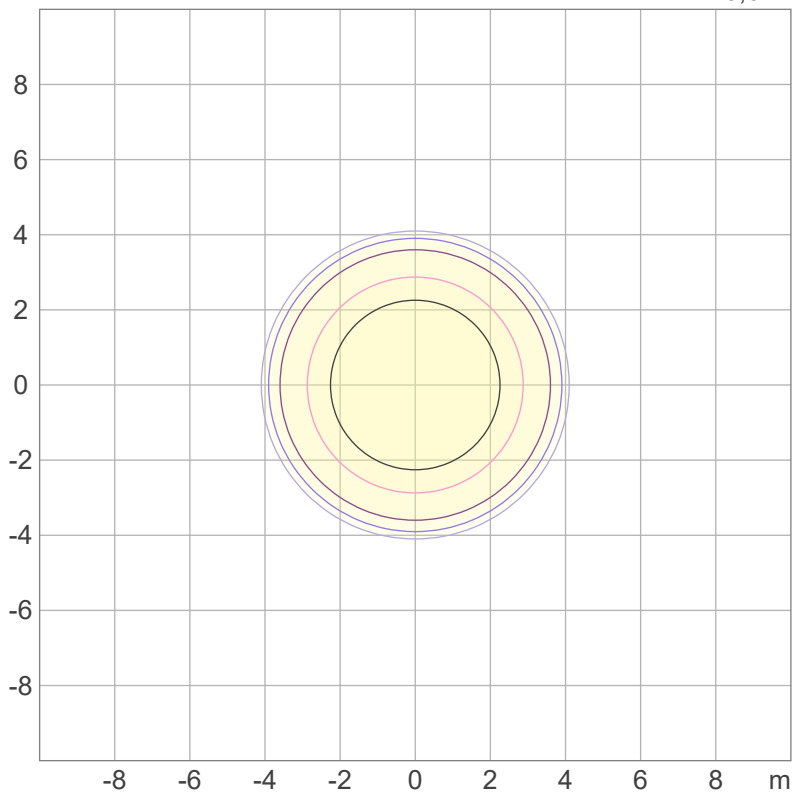

3%	2,60 lx
5%	4,34 lx
10%	8,68 lx
30%	26,0 lx
50%	43,4 lx

Conditions:

Number of c-planes: 2

Lux at center: 86,8 lx

*Lux distribution on a surface when lamp is mounted at 10 meters from the surface.*





Total lumen output:

866 lm

Peak candela output:

31922 cd

PRODUCT NAME:

ECLFRCTPM

MEASURAMENT CONDITIONS:

Beam angle:

Min Zoom

Target:

Amber - HB

Operator:

Salvatore Giglio

Date and time:

03/10/2023 11:09:00

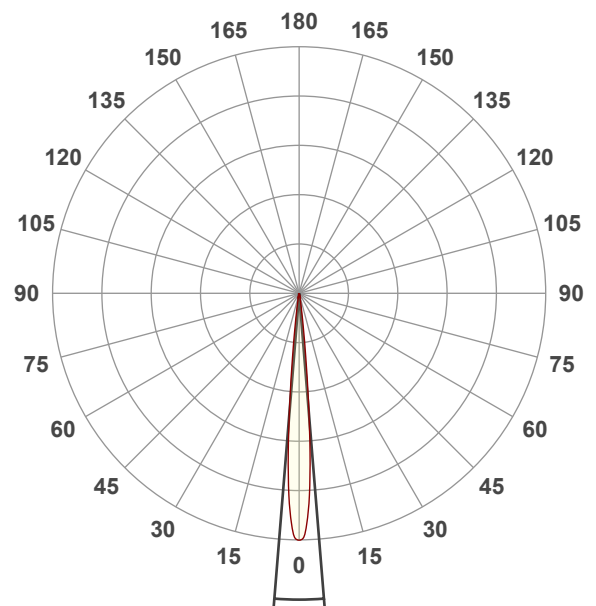

Beam angle 50%: 9,3°

Field angle 10%: 15,2°

Cut off angle 2.5%: 19,8°

Spectra

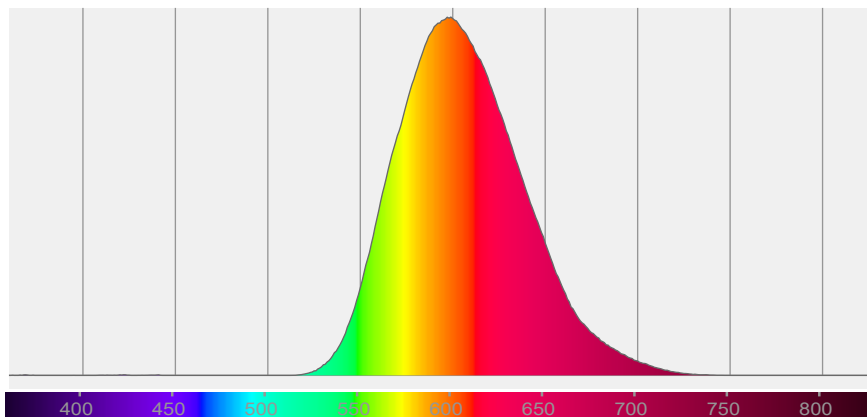

# BEAM DETAILS



Beam angle 50%	Field angle 10%	Cut off angle 2,5%	Intensity ratio in 120° cone	Intensity ratio in 90° cone
9,3°	15,2°	19,8°	100,0%	100,0%

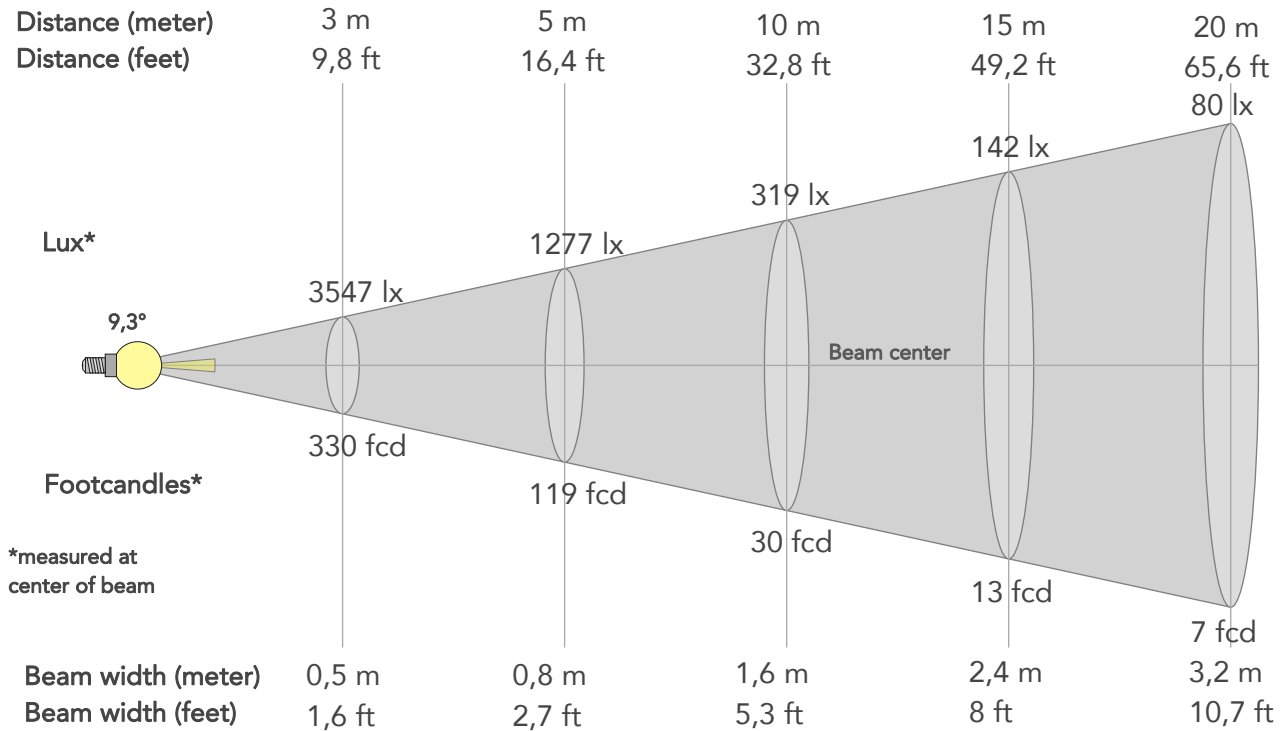

## BEAM INTENSITIES AND WIDTHS

Distance	1m	2m	3m	4m	5m	7,5m	10m	15m	20m	25m	30m	40m	50m
Distance	3,3ft	6,6ft	9,8ft	13,1ft	16,4ft	24,6ft	32,8ft	49,2ft	65,6ft	82ft	98,4ft	131,2ft	164ft
Lux	31922lx	7980lx	3547lx	1995lx	1277lx	567lx	319lx	142lx	80lx	51lx	35lx	20lx	13lx
Footcand.	2966fcd	741fcd	330fcd	185fcd	119fcd	53fcd	30fcd	13fcd	7fcd	5fcd	3fcd	2fcd	1fcd
Beam wid.	0,2m	0,3m	0,5m	0,6m	0,8m	1,2m	1,6m	2,4m	3,2m	4,1m	4,9m	6,5m	8,1m
Beam wid.	0,5ft	1,1ft	1,6ft	2,1ft	2,7ft	4ft	5,3ft	8ft	10,7ft	13,3ft	16ft	21,3ft	26,6ft

## LINEAR DISTRIBUTION DIAGRAM

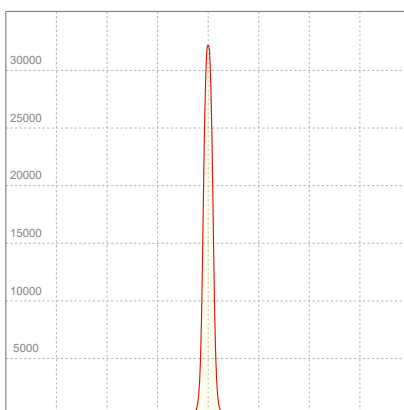

## ELECTRICAL SPECIFICATIONS

Input voltage	Input current	Input power	Effeciency
228V	0,454A	89,3W	10lm/W
Power FC			
0,86			

## ISO CANDELA DIAGRAM

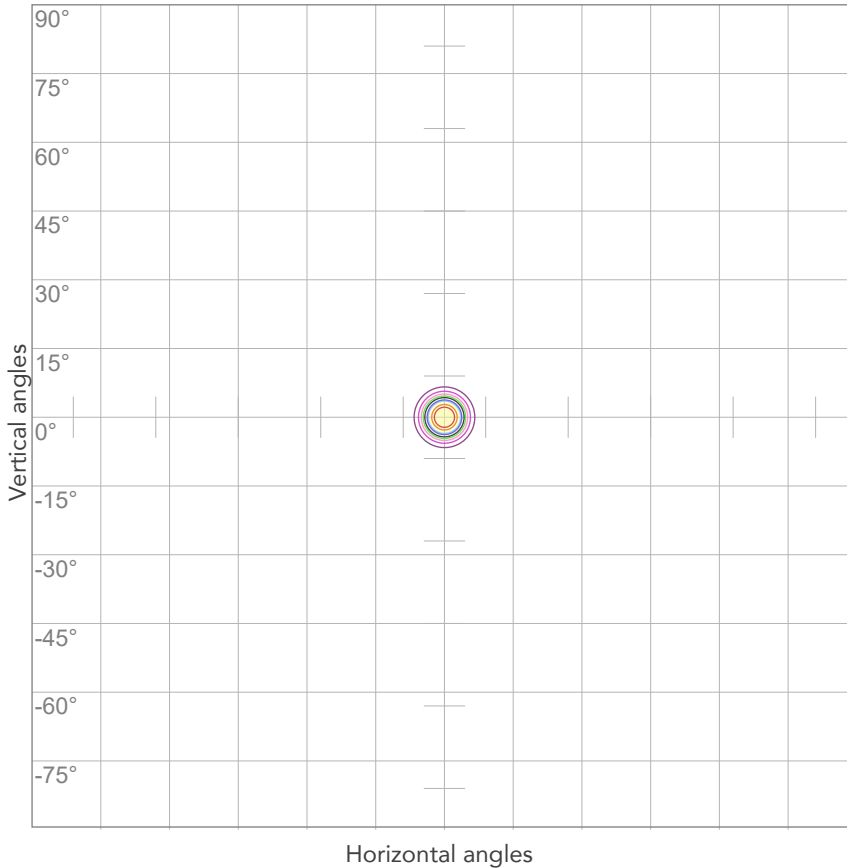

10%	3192 cd
20%	6384 cd
30%	9577 cd
40%	12769 cd
50%	15961 cd
60%	19153 cd
70%	22345 cd
80%	25537 cd

Conditions:

Number of c-planes: 2

Candela at center: 31922 cd

## ISO LUX DIAGRAM

MH: 10,0 m

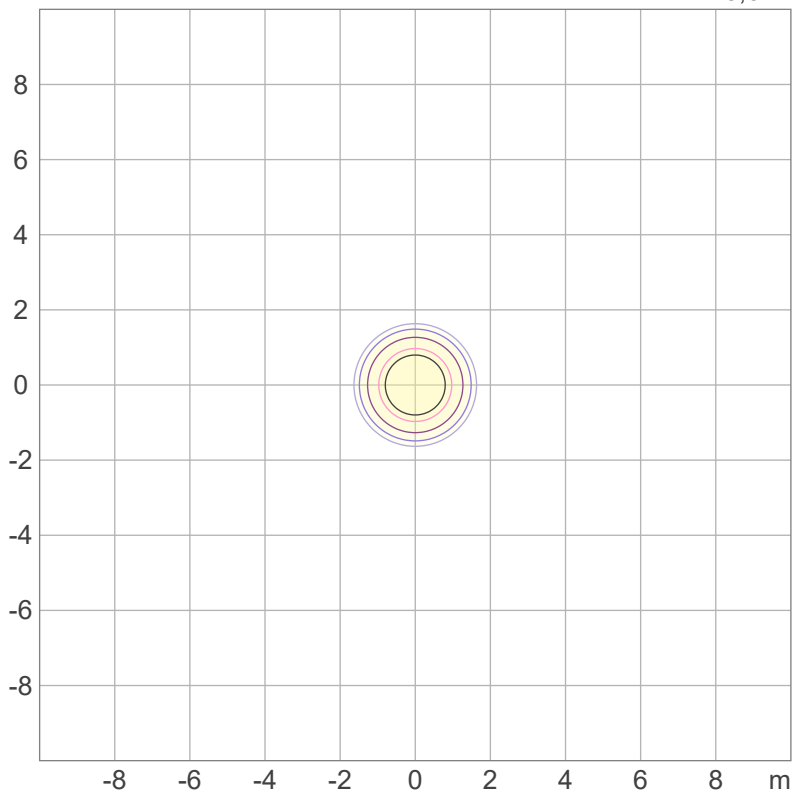

3%	9,58 lx
5%	16,0 lx
10%	31,9 lx
30%	95,8 lx
50%	160 lx

Conditions:

Number of c-planes: 2

Lux at center: 319 lx

*Lux distribution on a surface when lamp is mounted at 10 meters from the surface.*



Total lumen output:

8329 lm

Peak candela output:

9693 cd

Light quality:

CRI: 96,5

Color temperature:

2808 K

**PRODUCT NAME:**

ECLFRCTPM

**MEASURAMENT CONDITIONS:**

Beam angle:

Max Zoom

Target:

2800K - HB

Operator:

Salvatore Giglio

Date and time:

03/10/2023 10:45:14

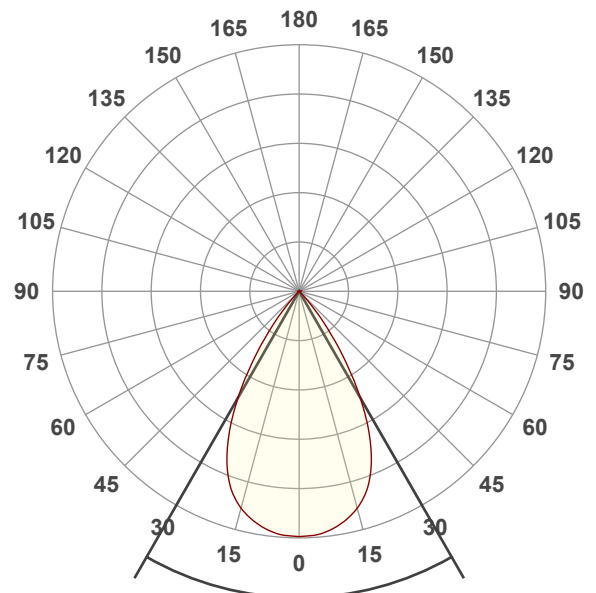

Spectra

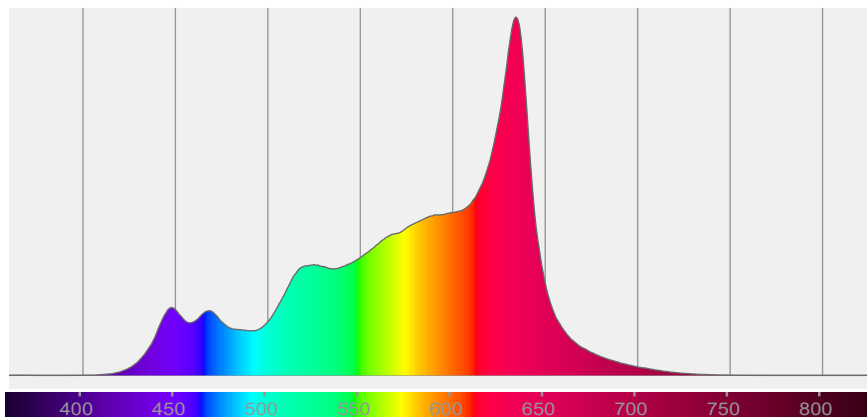

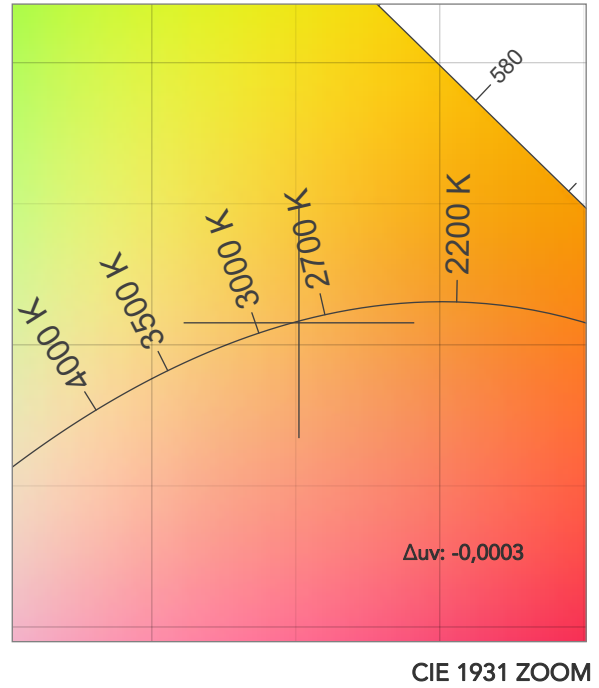
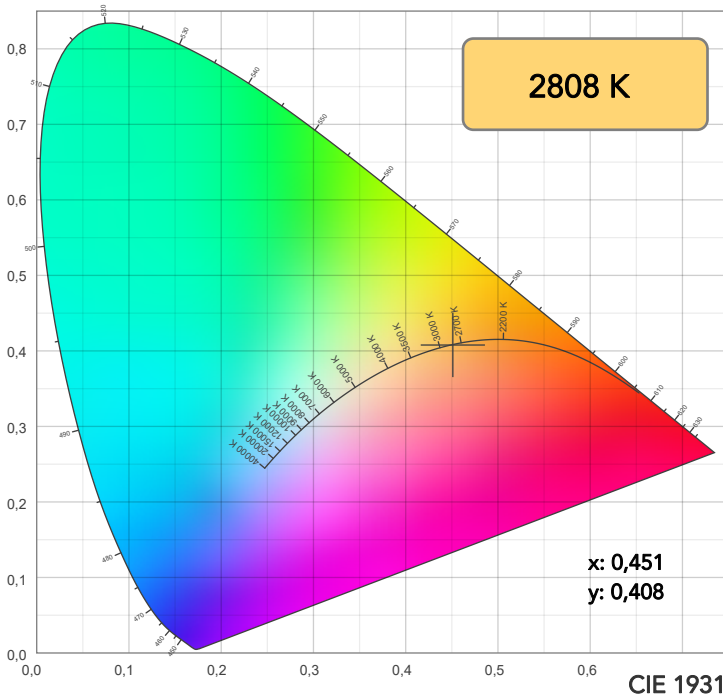

**TM30: 93,1**

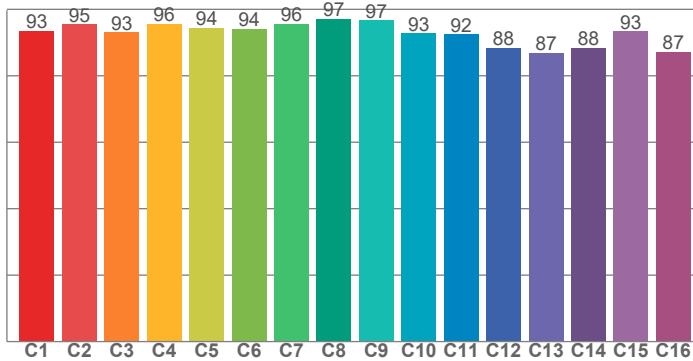

**CRI: 96,5 (R1-R8)**

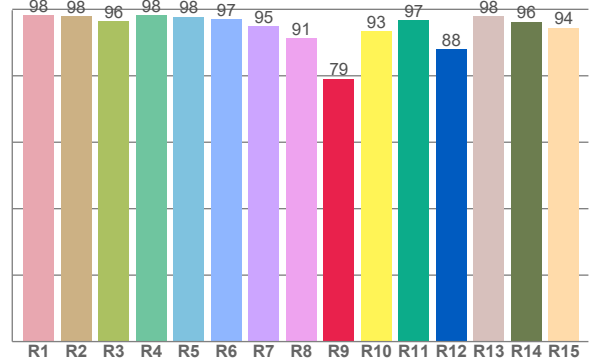

**CQS: 93,3**

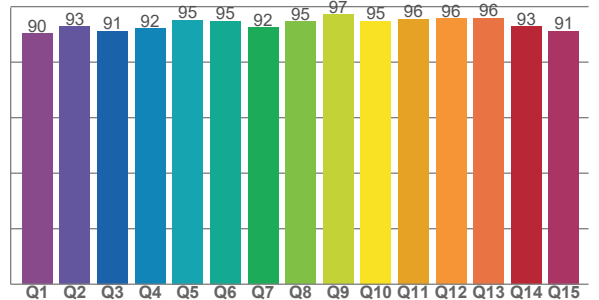

CRI R values, only R1-R8 are used to calculate final CRI value

R1	R2	R3	R4	R5	R6	R7	R8	R9	R10	R11	R12	R13	R14	R15
98,2	98,0	96,3	98,3	97,8	97,1	94,8	91,2	79,1	93,4	96,7	88,1	98,0	96,2	94,4

TM30 C values, 16 binned values out of total of 99 C values

C1	C2	C3	C4	C5	C6	C7	C8	C9	C10	C11	C12	C13	C14	C15	C16
93,5	95,5	93,1	95,7	94,4	94,1	95,6	97,2	96,7	92,8	92,4	88,5	87,0	88,4	93,4	87,2

CQS Q values

Q1	Q2	Q3	Q4	Q5	Q6	Q7	Q8	Q9	Q10	Q11	Q12	Q13	Q14	Q15
90,3	92,8	91,3	92,1	95,1	94,9	92,4	94,6	97,2	94,9	95,6	95,6	96,0	92,8	91,3

## COLOR PARAMETERS

Color temperature	Color rendering index	Red component	Color fidelity	Color gamut	Color quality scale	Television lighting index	Color coordinate cie 1931	Color coordinate cie 1931	Color deviation from black body
CCT	CRI	CRI R9	TM30 Rf	TM30 Rg	CQS	TLCI	x	y	Δuv
2808 K	96,5	79,1	93,1	100,4	93,3	84	0,451	0,408	-0,0003

# TM30 DETAILS

**Rf 93,1**  
Fidelity index Rf

**Rg 100,4**  
Gammut index

Hue Bin	R <sub>f</sub>	Graphic shifts (%)	
		Chroma	Hue
1	93	-3%	0%
2	95	-2%	1%
3	93	-1%	3%
4	96	-1%	1%
5	94	1%	3%
6	94	3%	2%
7	96	-1%	0%
8	97	1%	-1%
9	97	0%	2%
10	93	0%	4%
11	92	2%	5%
12	88	5%	-3%
13	87	3%	-10%
14	88	3%	-9%
15	93	-1%	-3%
16	87	-2%	-10%

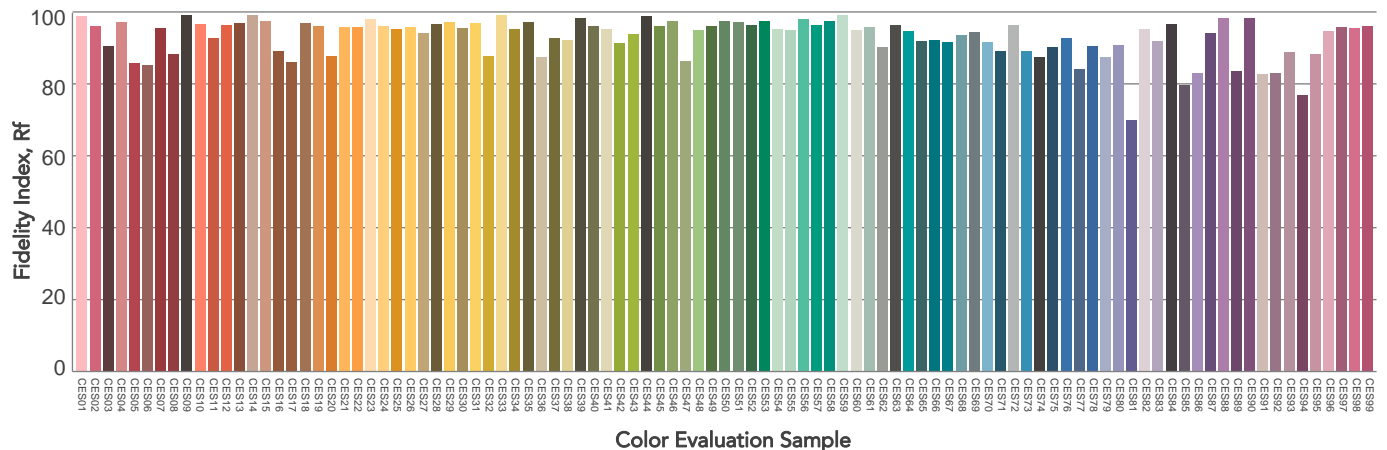
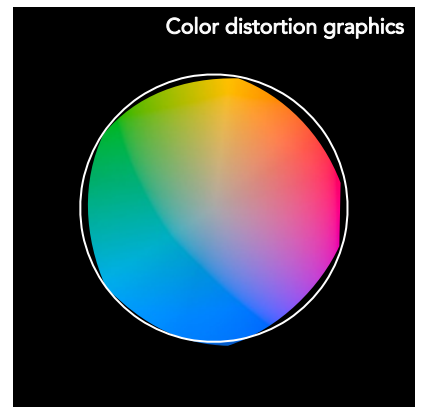
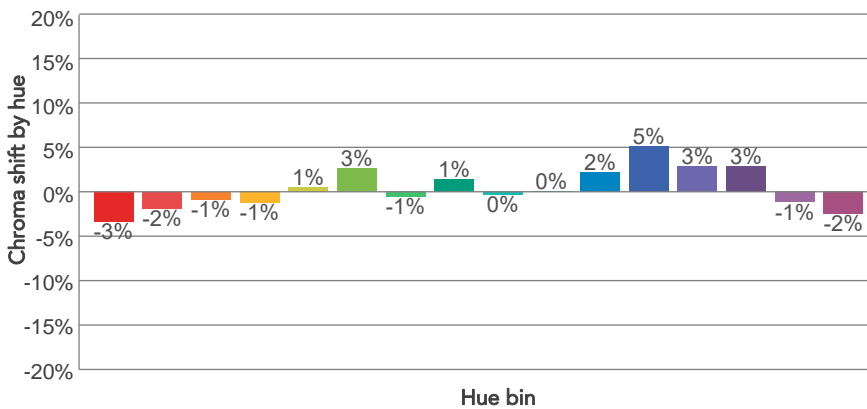
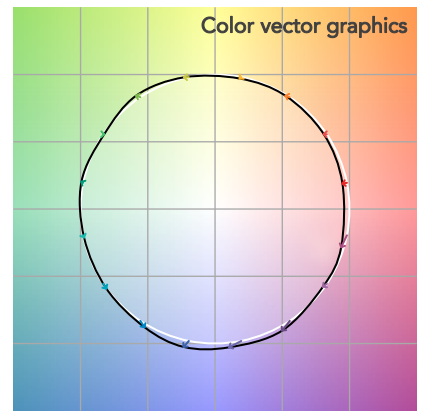
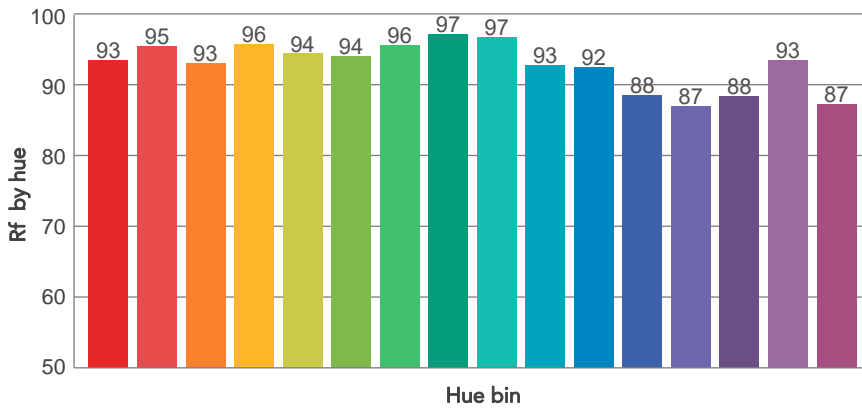
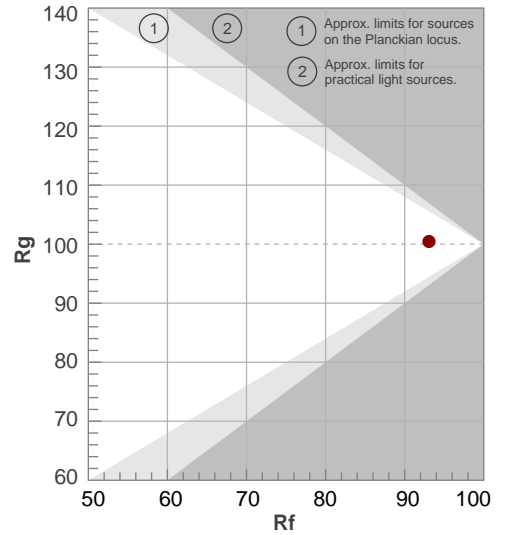

# BEAM DETAILS



Beam angle 50%	Field angle 10%	Cut off angle 2,5%	Intensity ratio in 120° cone	Intensity ratio in 90° cone
59,7°	81°	89°	100,0%	99,7%

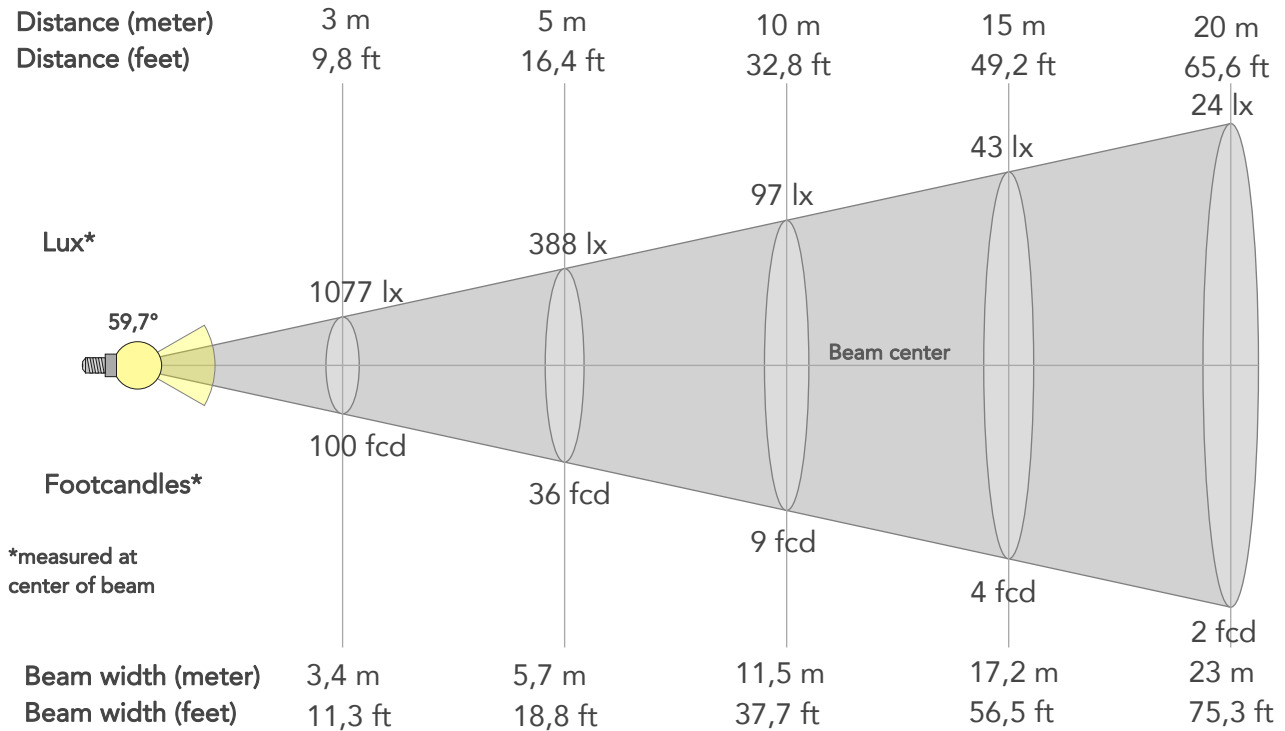

## BEAM INTENSITIES AND WIDTHS

Distance	1m	2m	3m	4m	5m	7,5m	10m	15m	20m	25m	30m	40m	50m
Distance	3,3ft	6,6ft	9,8ft	13,1ft	16,4ft	24,6ft	32,8ft	49,2ft	65,6ft	82ft	98,4ft	131,2ft	164ft
Lux	9693lx	2423lx	1077lx	606lx	388lx	172lx	97lx	43lx	24lx	16lx	11lx	6lx	4lx
Footcand.	901fcd	225fcd	100fcd	56fcd	36fcd	16fcd	9fcd	4fcd	2fcd	1fcd	1fcd	1fcd	0fcd
Beam wid.	1,1m	2,3m	3,4m	4,6m	5,7m	8,6m	11,5m	17,2m	23m	28,7m	34,4m	45,9m	57,4m
Beam wid.	3,8ft	7,6ft	11,3ft	15ft	18,8ft	28,2ft	37,7ft	56,5ft	75,3ft	94,2ft	113ft	150,6ft	188,3ft

## LINEAR DISTRIBUTION DIAGRAM

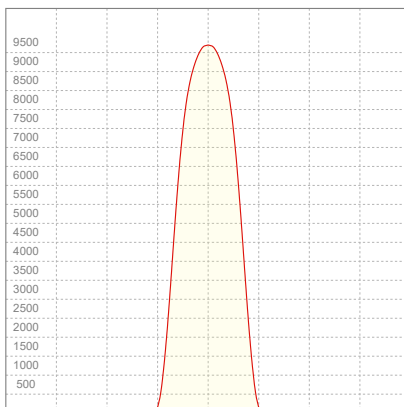

## ELECTRICAL SPECIFICATIONS

Input voltage	Input current	Input power	Effeciency
228V	1,11A	248,5W	34lm/W

## ISO CANDELA DIAGRAM

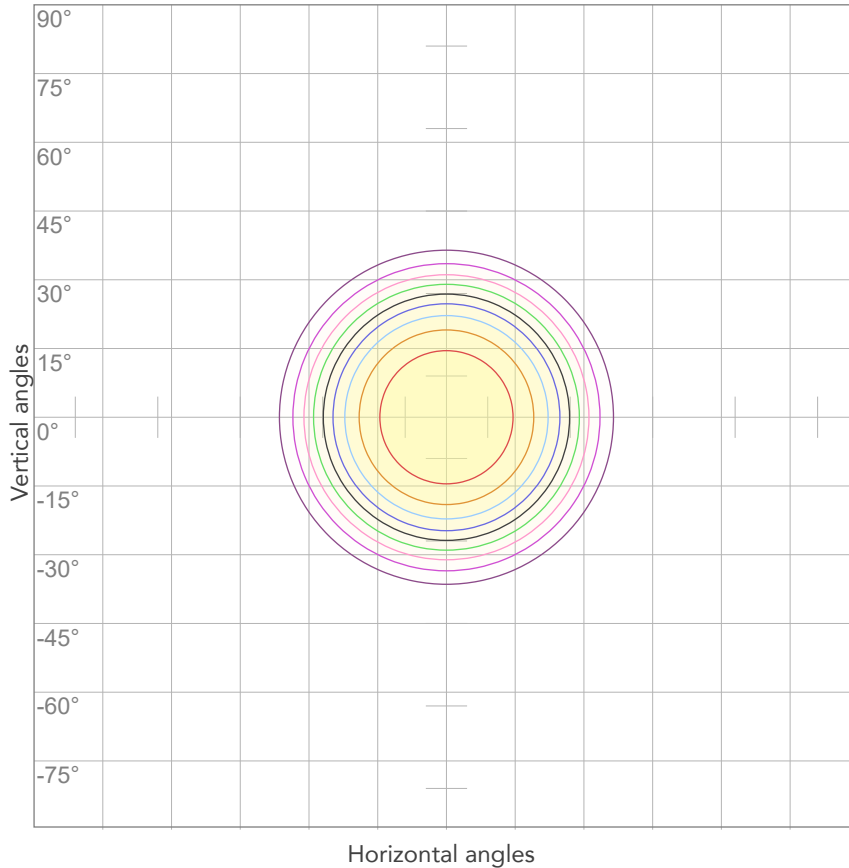

10%	969 cd
20%	1939 cd
30%	2908 cd
40%	3877 cd
50%	4846 cd
60%	5816 cd
70%	6785 cd
80%	7754 cd

Conditions:

Number of c-planes: 2

Candela at center: 9693 cd

## ISO LUX DIAGRAM

MH: 10,0 m

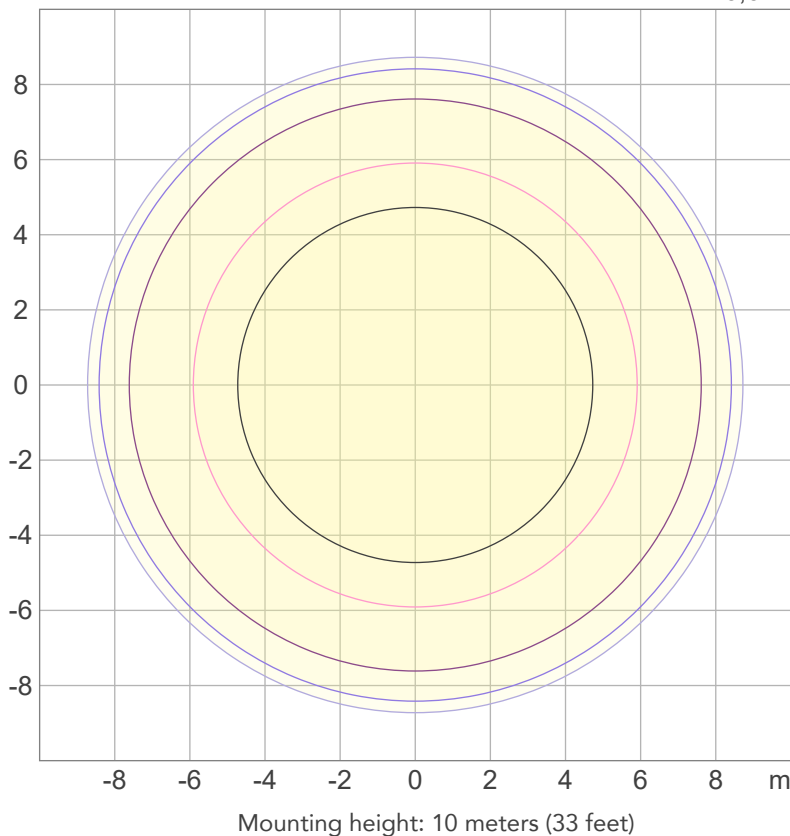

3%	2,91 lx
5%	4,85 lx
10%	9,69 lx
30%	29,1 lx
50%	48,5 lx

Conditions:

Number of c-planes: 2

Lux at center: 96,9 lx

*Lux distribution on a surface when lamp is mounted at 10 meters from the surface.*





Total lumen output:

6341 lm

Peak candela output:

33409 cd

Light quality:

CRI: 96,4

Color temperature:

2824 K

**PRODUCT NAME:**

ECLFRCTPM

**MEASURAMENT CONDITIONS:**

Beam angle:

Med Zoom

Target:

2800K - HB

Operator:

Salvatore Giglio

Date and time:

03/10/2023 11:51:13

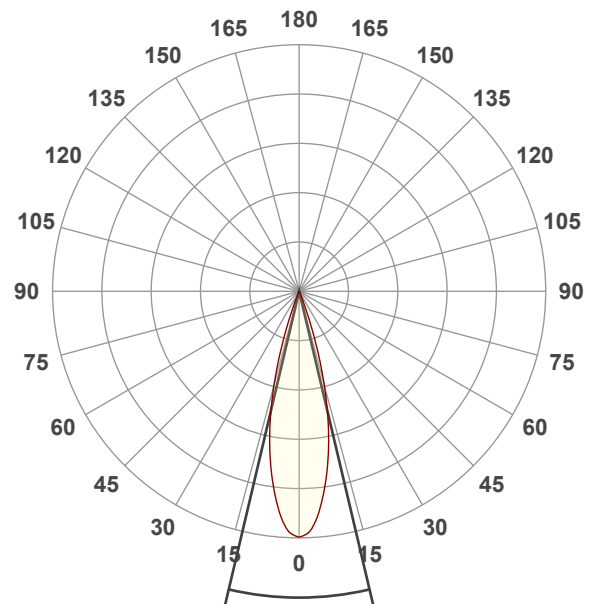

Beam angle 50%: 26,6°

Field angle 10%: 40,3°

Cut off angle 2.5%: 45,2°

Spectra

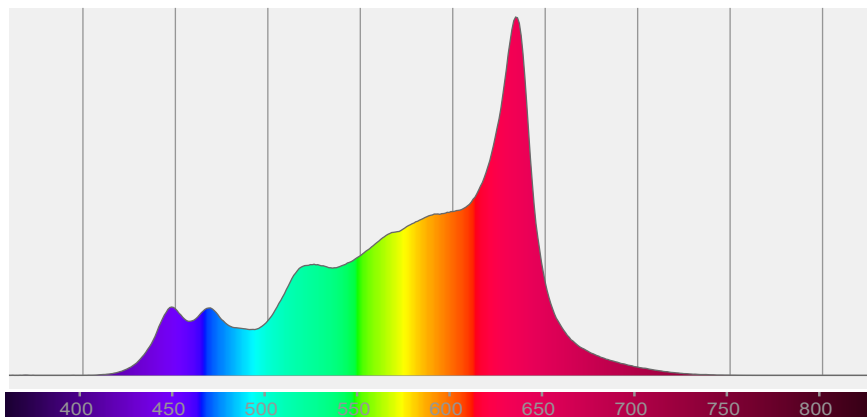

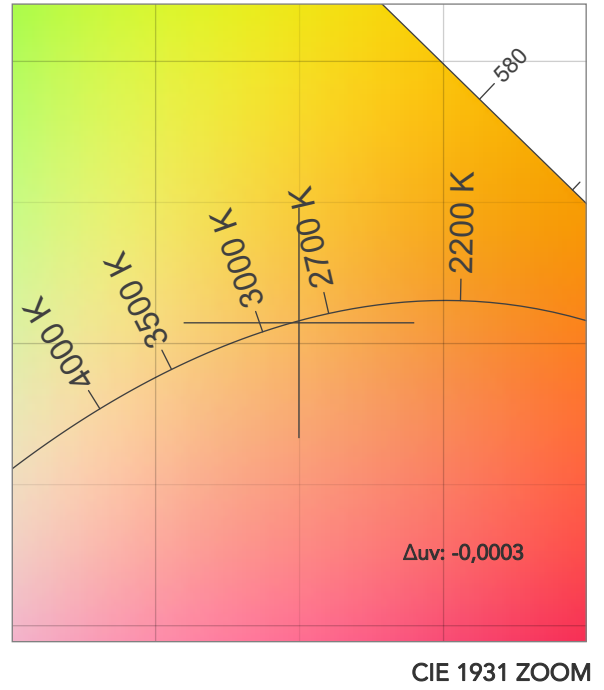
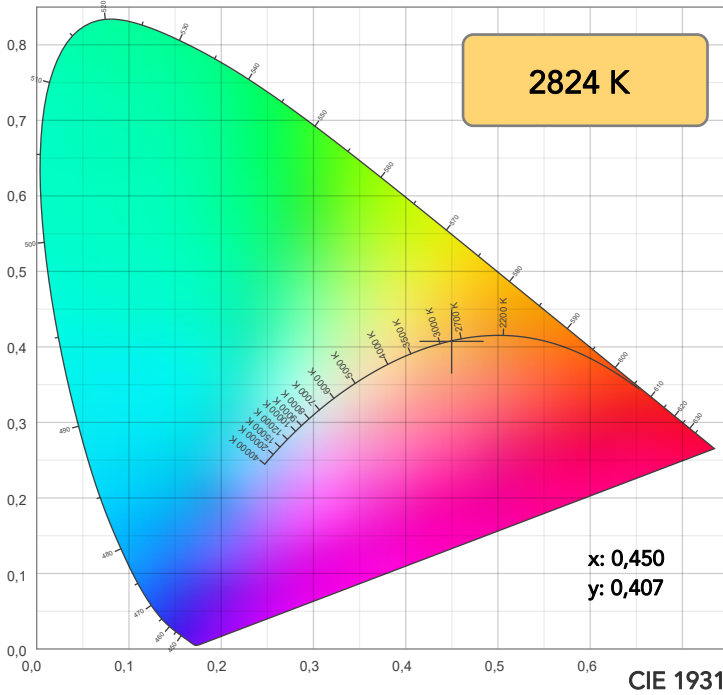

TM30: 93,0

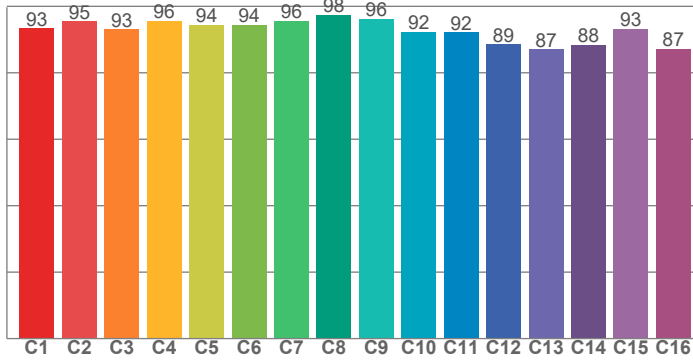

CRI: 96,4 (R1-R8)

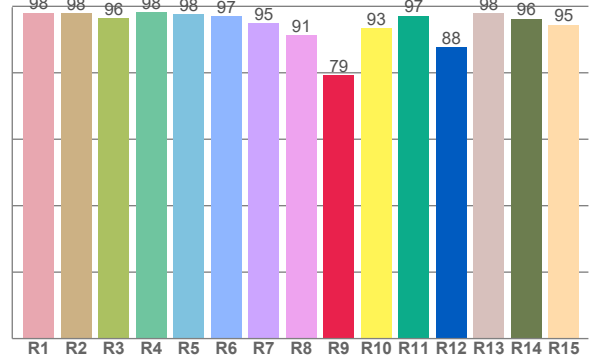

CRI R values, only R1-R8 are used to calculate final CRI value

R1	R2	R3	R4	R5	R6	R7	R8	R9	R10	R11	R12	R13	R14	R15
98,1	98,0	96,4	98,2	97,7	97,1	94,8	91,3	79,3	93,3	97,1	87,7	97,9	96,3	94,5

TM30 C values, 16 binned values out of total of 99 C values

C1	C2	C3	C4	C5	C6	C7	C8	C9	C10	C11	C12	C13	C14	C15	C16
93,4	95,4	93,1	95,6	94,4	94,3	95,6	97,5	96,3	92,3	92,1	88,5	87,0	88,4	93,3	87,1

CQS Q values

Q1	Q2	Q3	Q4	Q5	Q6	Q7	Q8	Q9	Q10	Q11	Q12	Q13	Q14	Q15
90,4	92,9	91,2	91,7	94,8	95,1	92,6	94,6	97,2	94,9	95,4	95,5	95,9	92,9	91,4

CQS: 93,3

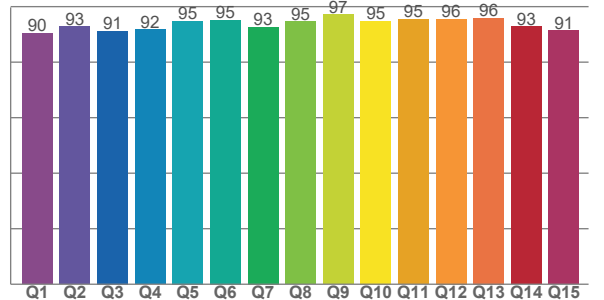

COLOR PARAMETERS

Color temperature	Color rendering index	Red component	Color fidelity	Color gamut	Color quality scale	Television lighting index	Color coordinate cie 1931	Color coordinate cie 1931	Color deviation from black body
CCT	CRI	CRI R9	TM30 Rf	TM30 Rg	CQS	TLCI	x	y	$\Delta uv$
2824 K	96,4	79,3	93,0	100,3	93,3	85	0,450	0,407	-0,0003

# TM30 DETAILS

**Rf 93,0**  
Fidelity index Rf

**Rg 100,3**  
Gammut index

Hue Bin	R <sub>f</sub>	Graphic shifts (%)	
		Chroma	Hue
1	93	-3%	0%
2	95	-2%	1%
3	93	-1%	3%
4	96	-1%	1%
5	94	0%	3%
6	94	2%	2%
7	96	-1%	0%
8	98	1%	0%
9	96	0%	2%
10	92	0%	5%
11	92	2%	5%
12	89	5%	-3%
13	87	3%	-10%
14	88	3%	-9%
15	93	-1%	-3%
16	87	-2%	-10%

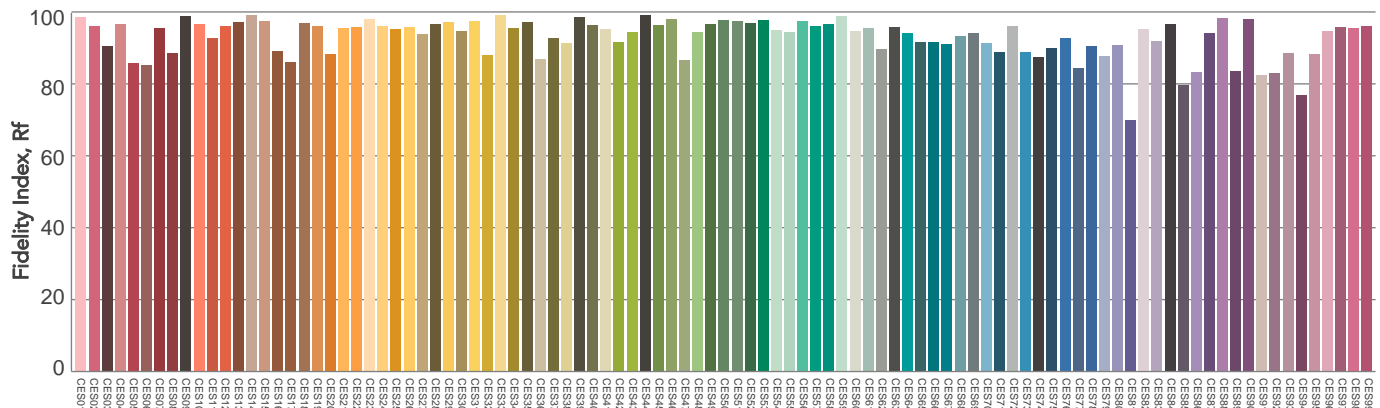
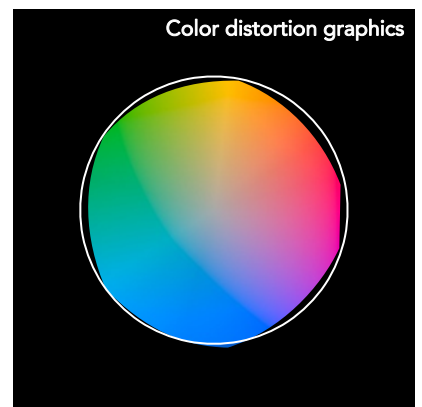
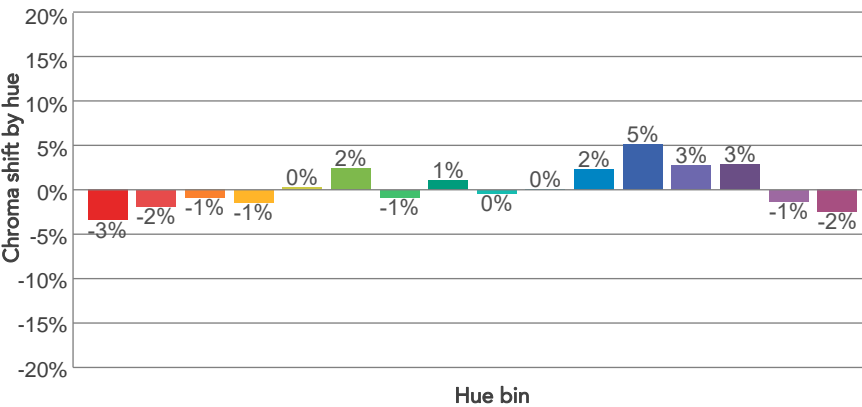
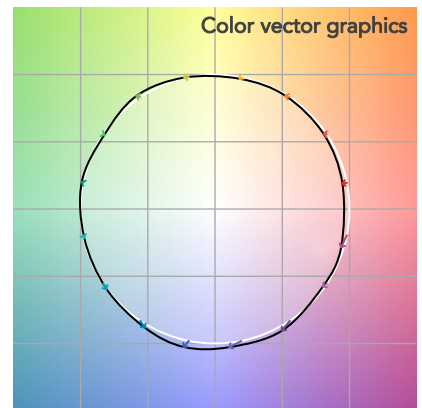
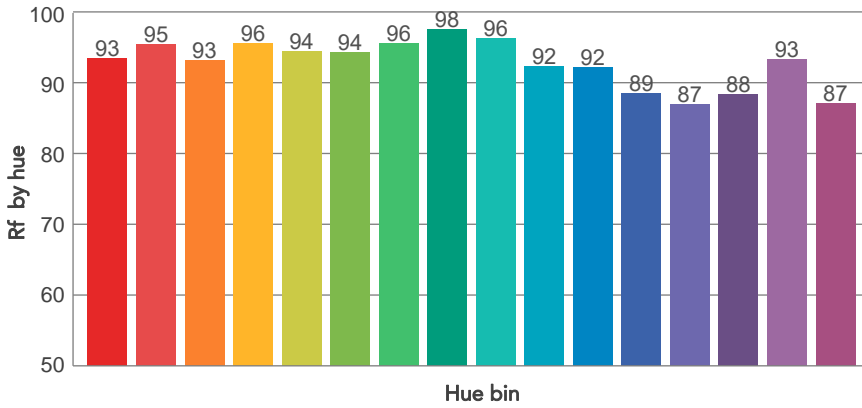
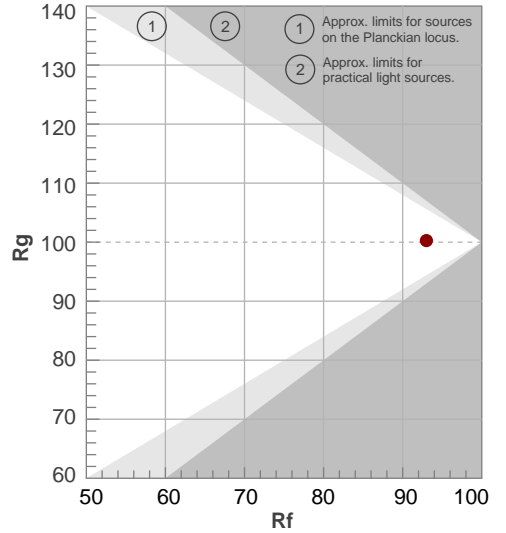

Color Evaluation Sample

# BEAM DETAILS



Beam angle 50%	Field angle 10%	Cut off angle 2,5%	Intensity ratio in 120° cone	Intensity ratio in 90° cone
26,6°	40,3°	45,2°	100,0%	100,0%

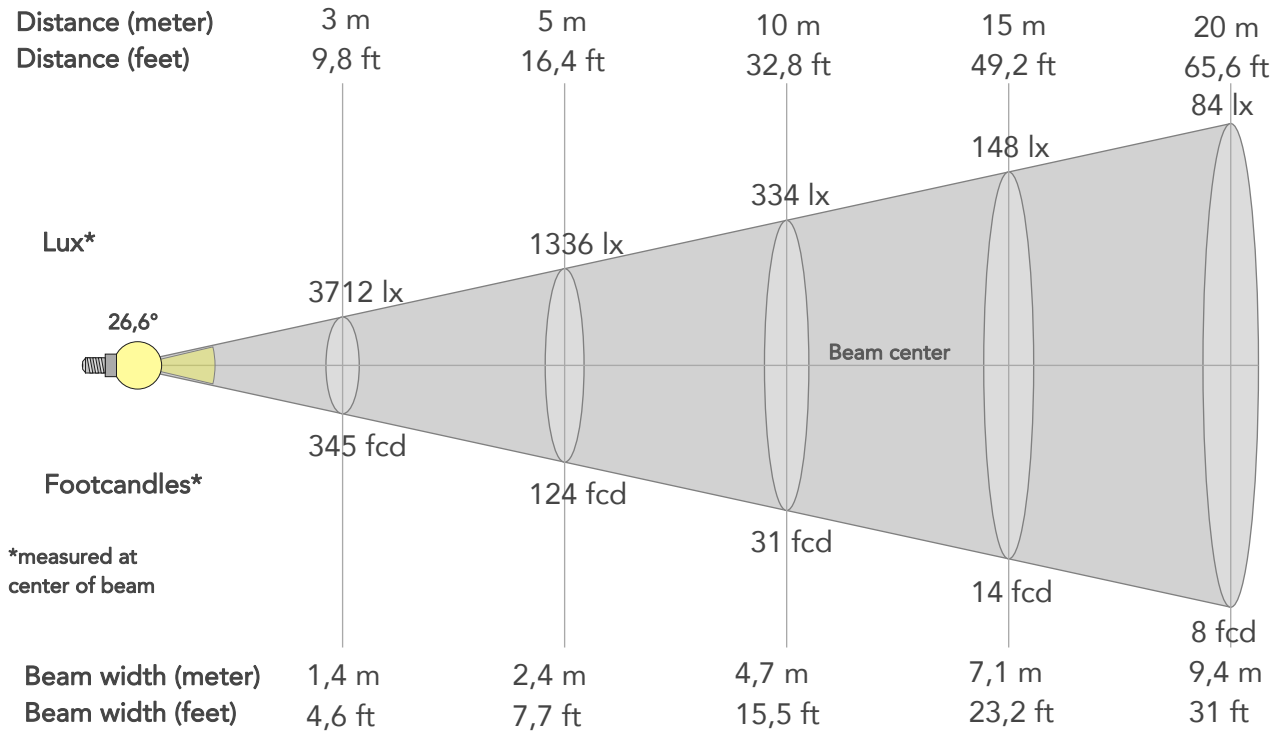

## BEAM INTENSITIES AND WIDTHS

Distance	1m	2m	3m	4m	5m	7,5m	10m	15m	20m	25m	30m	40m	50m
Distance	3,3ft	6,6ft	9,8ft	13,1ft	16,4ft	24,6ft	32,8ft	49,2ft	65,6ft	82ft	98,4ft	131,2ft	164ft
Lux	33409lx	8352lx	3712lx	2088lx	1336lx	594lx	334lx	148lx	84lx	53lx	37lx	21lx	13lx
Footcand.	3104fcd	776fcd	345fcd	194fcd	124fcd	55fcd	31fcd	14fcd	8fcd	5fcd	3fcd	2fcd	1fcd
Beam wid.	0,5m	0,9m	1,4m	1,9m	2,4m	3,5m	4,7m	7,1m	9,4m	11,8m	14,2m	18,9m	23,6m
Beam wid.	1,6ft	3,1ft	4,6ft	6,2ft	7,7ft	11,6ft	15,5ft	23,2ft	31ft	38,7ft	46,5ft	62ft	77,5ft

## LINEAR DISTRIBUTION DIAGRAM

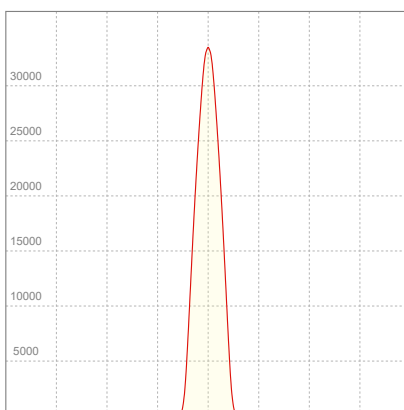

## ELECTRICAL SPECIFICATIONS

Input voltage	Input current	Input power	Effeciency
225V	1,13A	249,8W	25lm/W

## ISO CANDELA DIAGRAM

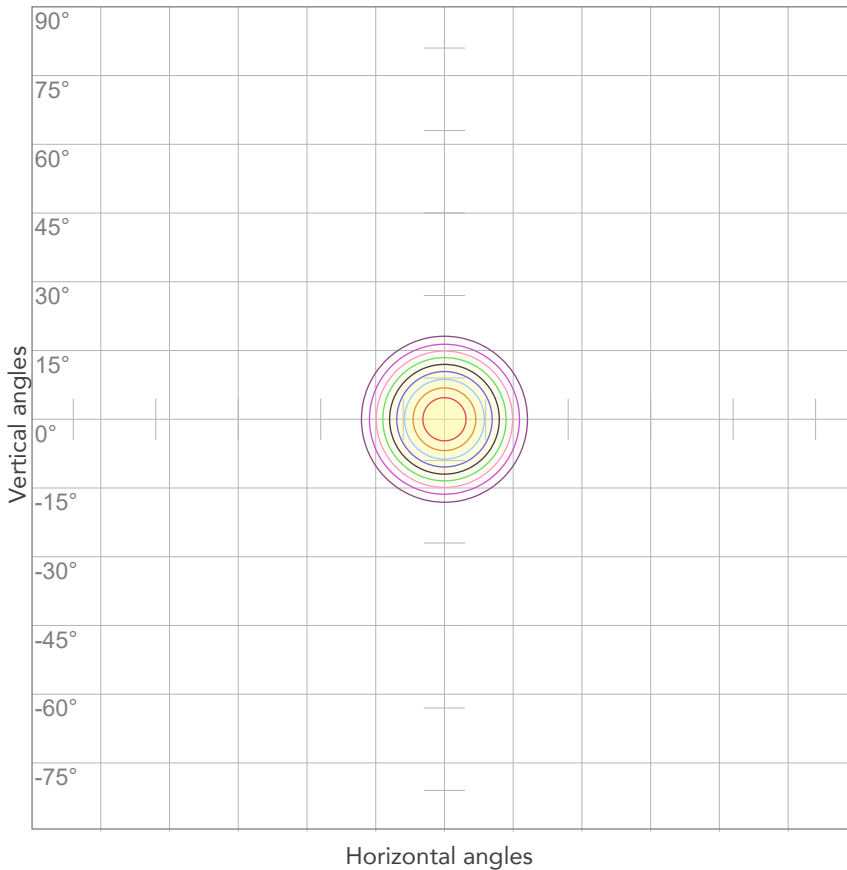

10%	3341 cd
20%	6682 cd
30%	10023 cd
40%	13363 cd
50%	16704 cd
60%	20045 cd
70%	23386 cd
80%	26727 cd

Conditions:

Number of c-planes: 2

Candela at center: 33409 cd

## ISO LUX DIAGRAM

MH: 10,0 m

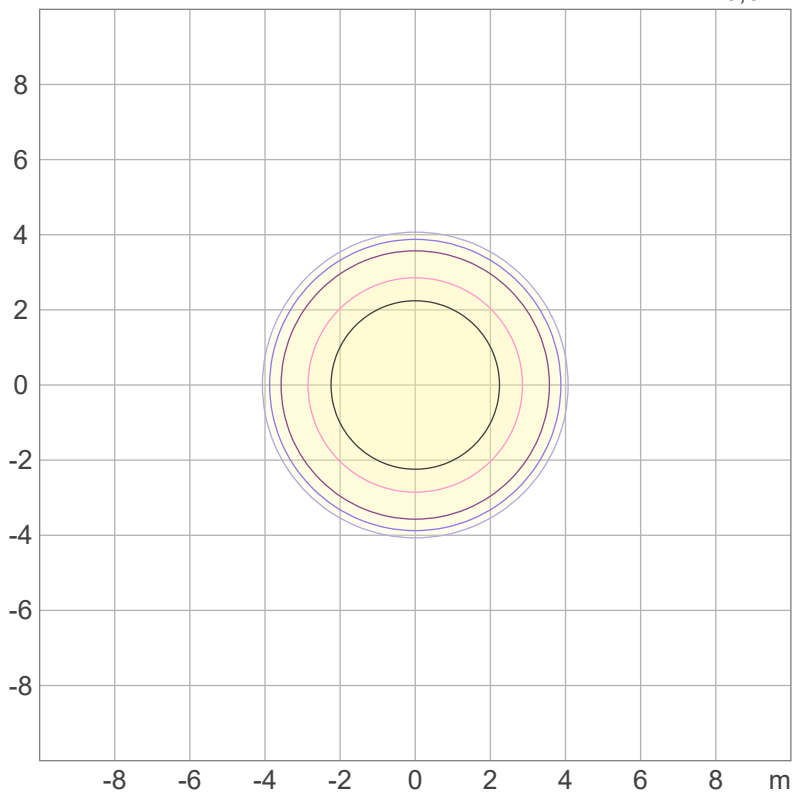

Mounting height: 10 meters (33 feet)

3%	10,0 lx
5%	16,7 lx
10%	33,4 lx
30%	100 lx
50%	167 lx

Conditions:

Number of c-planes: 2

Lux at center: 334 lx

*Lux distribution on a surface when lamp is mounted at 10 meters from the surface.*



Total lumen output:

3289 lm

Peak candela output:

122415 cd

Light quality:

CRI: 96,2

Color temperature:

2810 K

**PRODUCT NAME:**

ECLFRCTPM

**MEASURAMENT CONDITIONS:**

Beam angle:

Min Zoom

Target:

2800K - HB

Operator:

Salvatore Giglio

Date and time:

03/10/2023 11:48:25

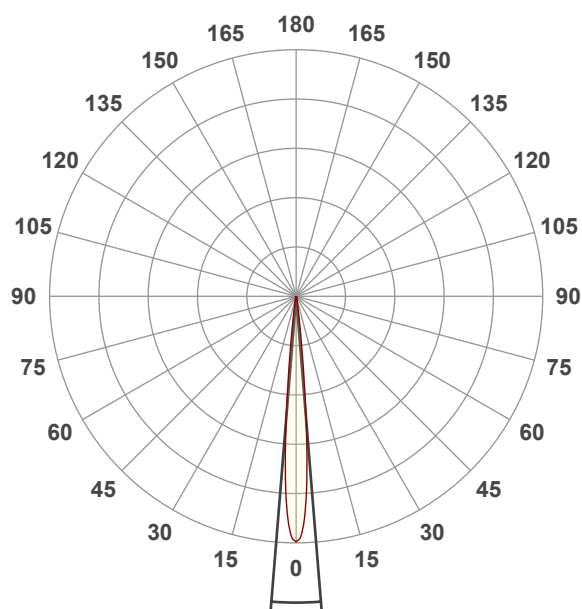

Beam angle 50%: 9,3°

Field angle 10%: 15,2°

Cut off angle 2.5%: 19,8°

Spectra

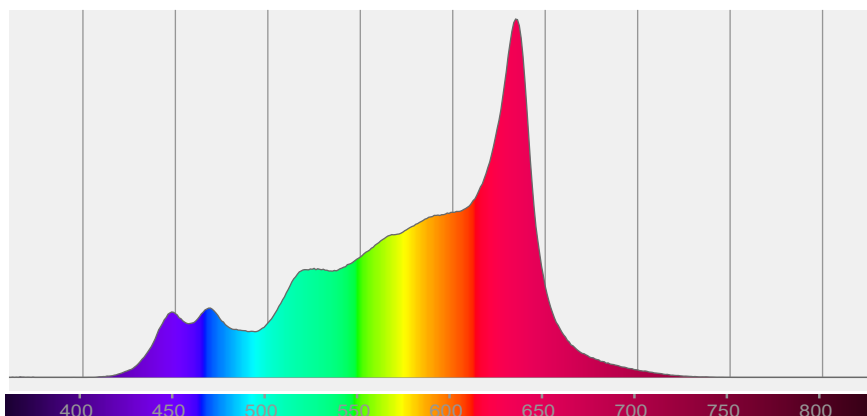

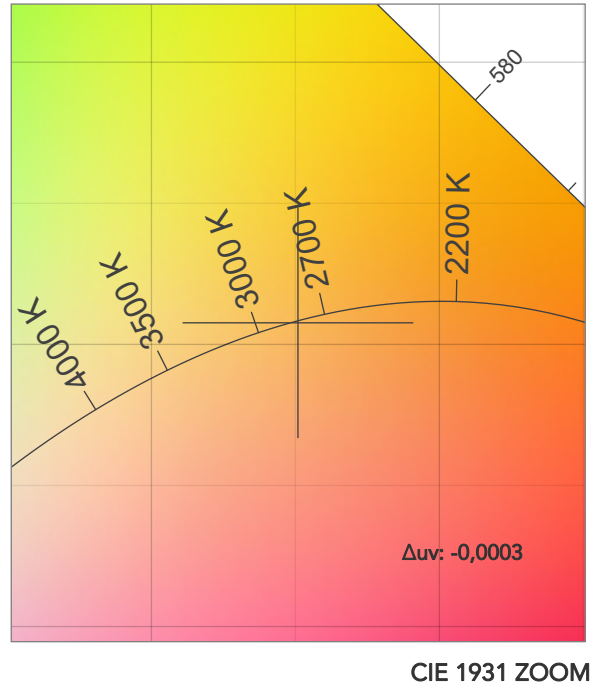
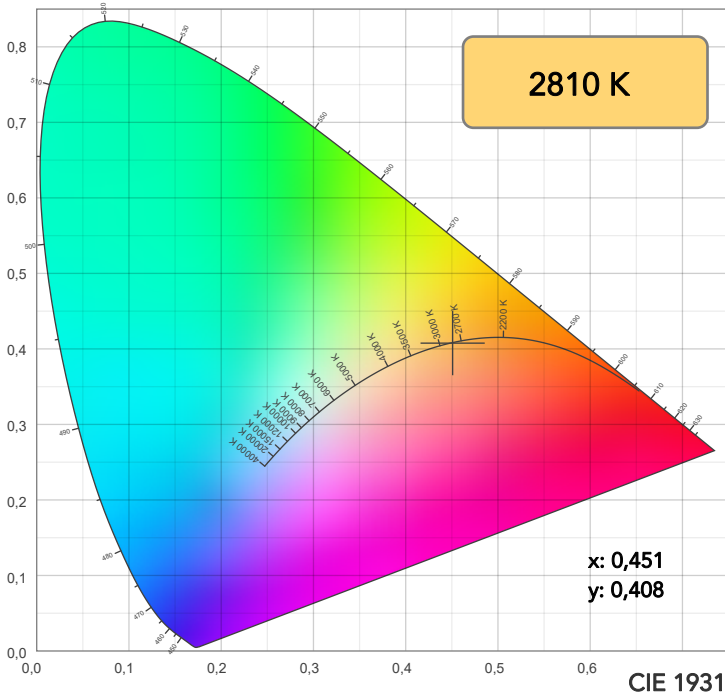

TM30: 92,7

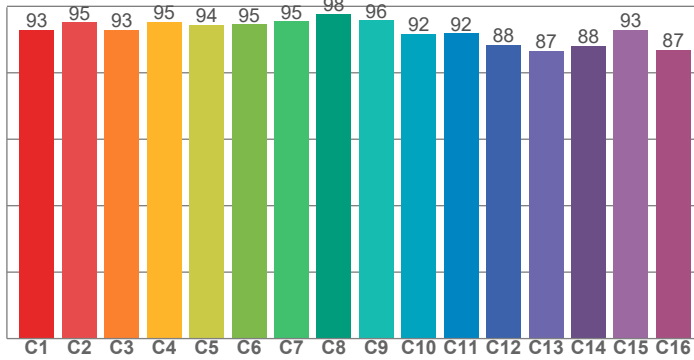

CRI: 96,2 (R1-R8)

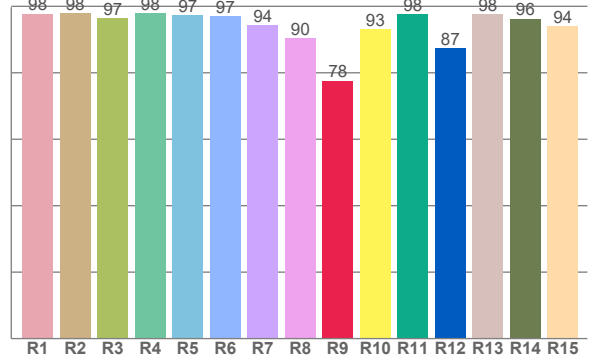

CQS: 93,1

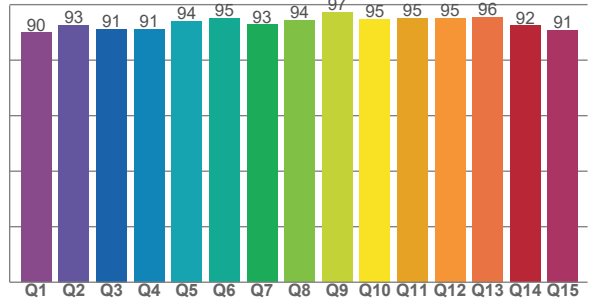

CRI R values, only R1-R8 are used to calculate final CRI value

R1	R2	R3	R4	R5	R6	R7	R8	R9	R10	R11	R12	R13	R14	R15
97,7	98,0	96,5	97,9	97,3	97,1	94,4	90,4	77,6	93,1	97,7	87,5	97,7	96,3	94,1

TM30 C values, 16 binned values out of total of 99 C values

C1	C2	C3	C4	C5	C6	C7	C8	C9	C10	C11	C12	C13	C14	C15	C16
92,9	95,1	92,9	95,4	94,4	94,5	95,4	97,8	95,8	91,7	91,8	88,4	86,6	88,1	92,9	86,8

CQS Q values

Q1	Q2	Q3	Q4	Q5	Q6	Q7	Q8	Q9	Q10	Q11	Q12	Q13	Q14	Q15
89,9	92,6	91,1	91,2	94,2	95,1	92,8	94,4	97,2	94,8	95,2	95,3	95,6	92,4	90,9

COLOR PARAMETERS

Color temperature	Color rendering index	Red component	Color fidelity	Color gamut	Color quality scale	Television lighting index	Color coordinate cie 1931	Color coordinate cie 1931	Color deviation from black body
CCT	CRI	CRI R9	TM30 Rf	TM30 Rg	CQS	TLCI	x	y	$\Delta uv$
2810 K	96,2	77,6	92,7	99,9	93,1	84	0,451	0,408	-0,0003

# TM30 DETAILS

**Rf 92,7**  
Fidelity index Rf

**Rg 99,9**  
Gammut index

Hue Bin	R <sub>f</sub>	Graphic shifts (%)	
		Chroma	Hue
1	93	-4%	0%
2	95	-2%	2%
3	93	-1%	3%
4	95	-2%	1%
5	94	0%	3%
6	95	2%	2%
7	95	-1%	0%
8	98	1%	0%
9	96	-1%	2%
10	92	0%	5%
11	92	2%	6%
12	88	5%	-3%
13	87	3%	-10%
14	88	3%	-9%
15	93	-2%	-3%
16	87	-3%	-10%

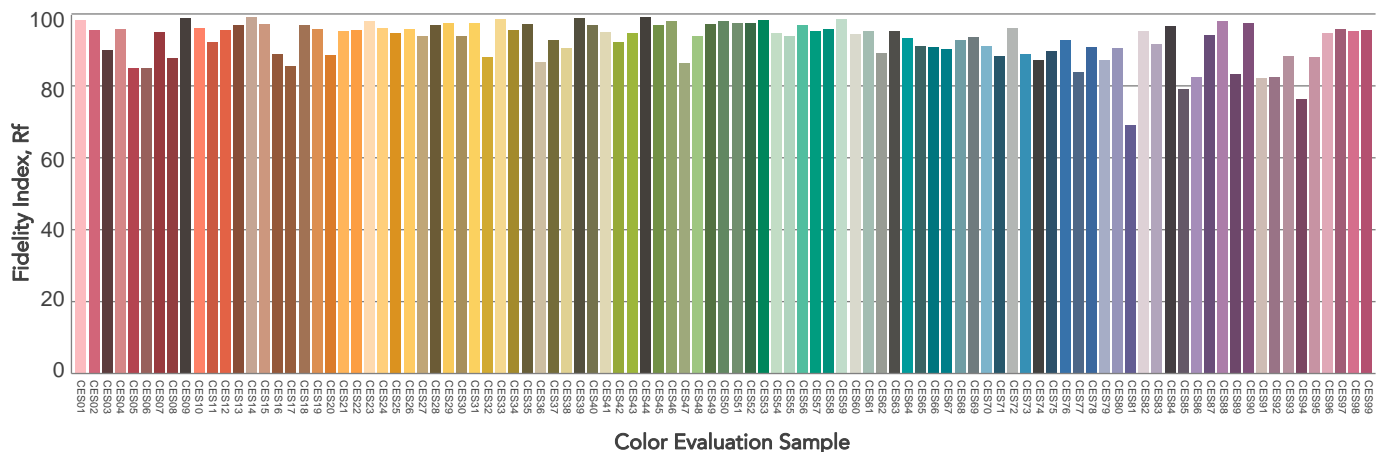
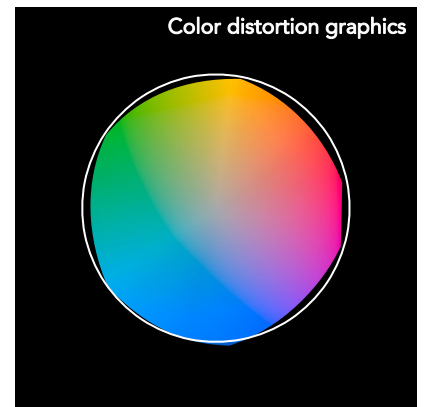
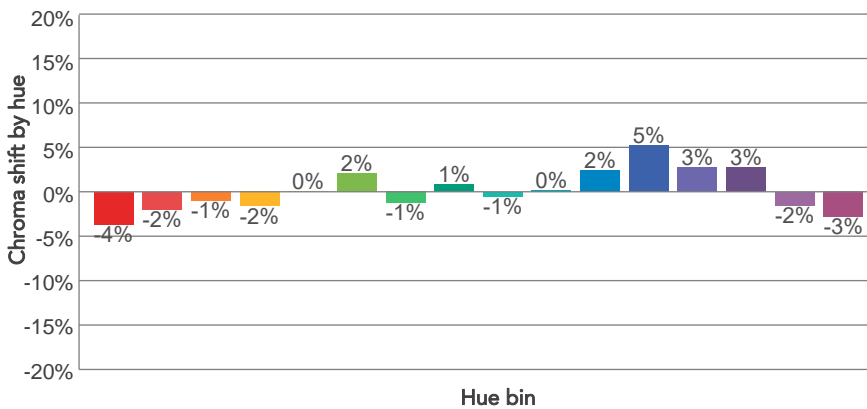
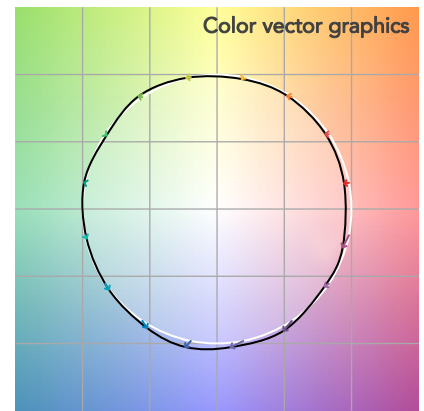
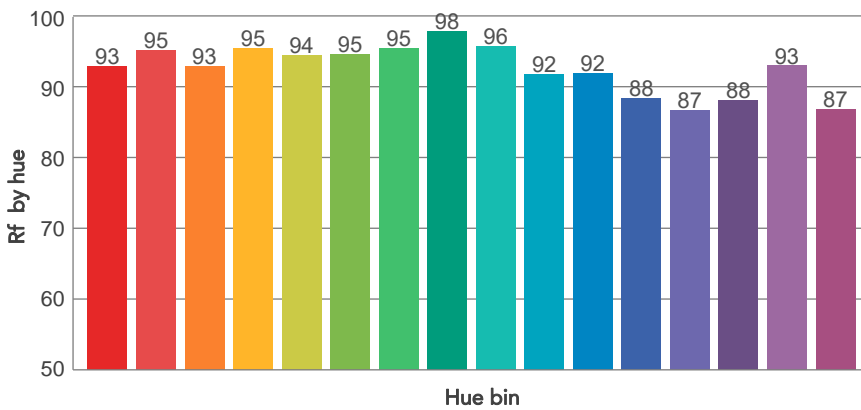
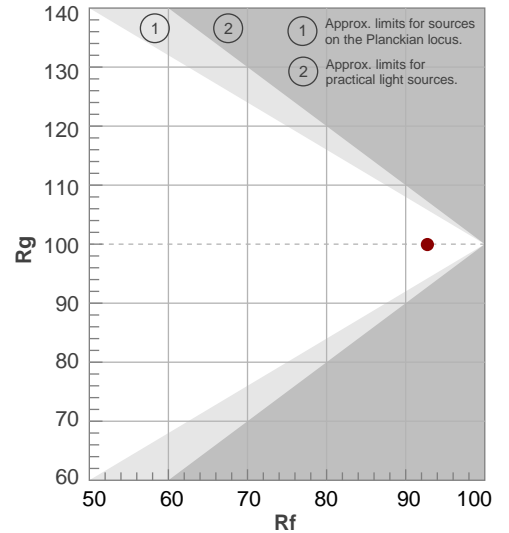



# BEAM DETAILS



Beam angle 50%	Field angle 10%	Cut off angle 2,5%	Intensity ratio in 120° cone	Intensity ratio in 90° cone
9,3°	15,2°	19,8°	100,0%	100,0%

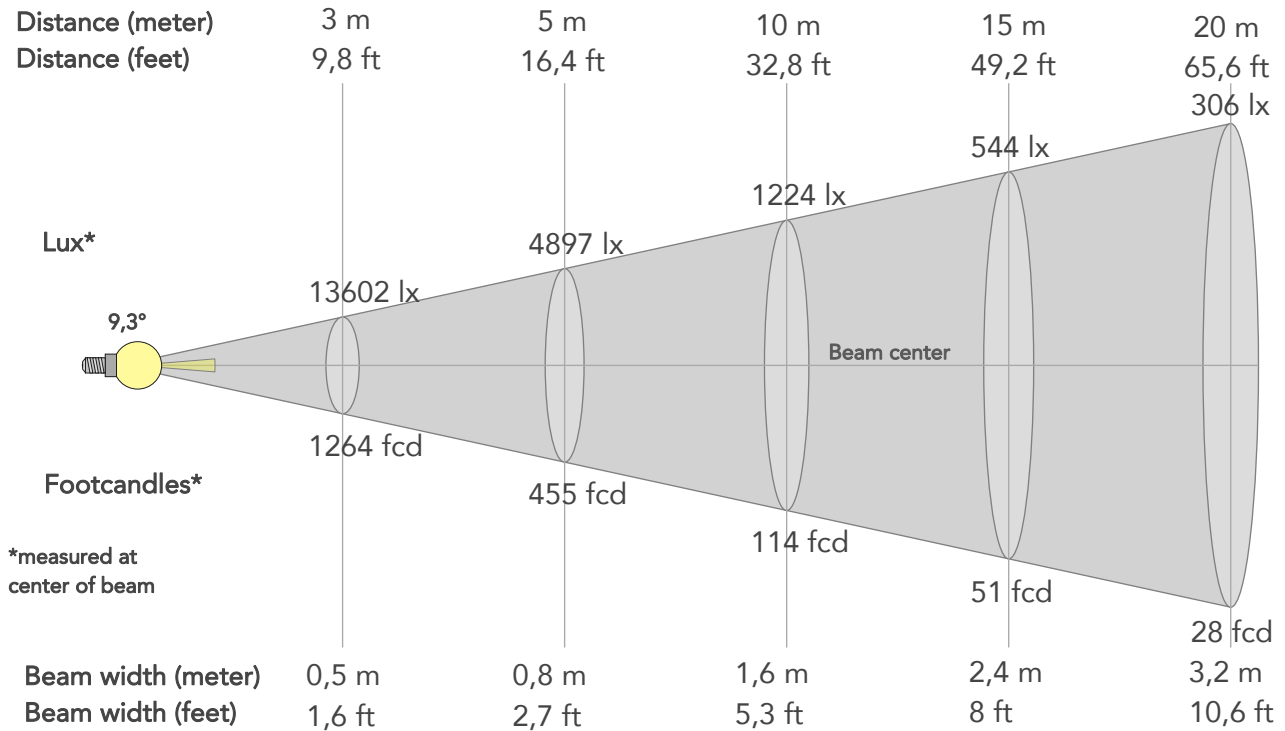

## BEAM INTENSITIES AND WIDTHS

Distance	1m	2m	3m	4m	5m	7,5m	10m	15m	20m	25m	30m	40m	50m
Distance	3,3ft	6,6ft	9,8ft	13,1ft	16,4ft	24,6ft	32,8ft	49,2ft	65,6ft	82ft	98,4ft	131,2ft	164ft
Lux	122415lx	30604lx	13602lx	7651lx	4897lx	2176lx	1224lx	544lx	306lx	196lx	136lx	77lx	49lx
Footcand.	11373fcd	2843fcd	1264fcd	711fcd	455fcd	202fcd	114fcd	51fcd	28fcd	18fcd	13fcd	7fcd	5fcd
Beam wid.	0,2m	0,3m	0,5m	0,6m	0,8m	1,2m	1,6m	2,4m	3,2m	4,1m	4,9m	6,5m	8,1m
Beam wid.	0,5ft	1,1ft	1,6ft	2,1ft	2,7ft	4ft	5,3ft	8ft	10,6ft	13,3ft	16ft	21,3ft	26,6ft

## LINEAR DISTRIBUTION DIAGRAM

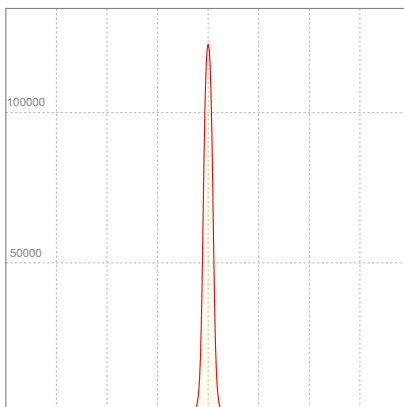

## ELECTRICAL SPECIFICATIONS

Input voltage	Input current	Input power	Effeciency
228V	1,12A	249,2W	13lm/W

## ISO CANDELA DIAGRAM

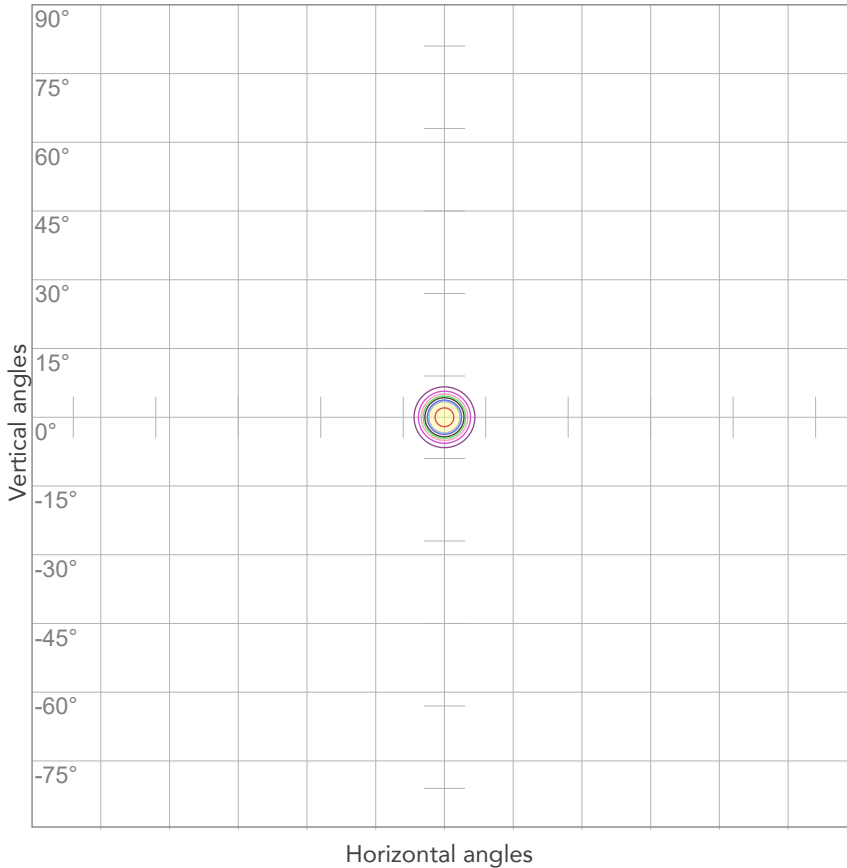

10%	12242 cd
20%	24483 cd
30%	36725 cd
40%	48966 cd
50%	61208 cd
60%	73449 cd
70%	85691 cd
80%	97932 cd

Conditions:

Number of c-planes: 2

Candela at center: 122415 cd

## ISO LUX DIAGRAM

MH: 10,0 m

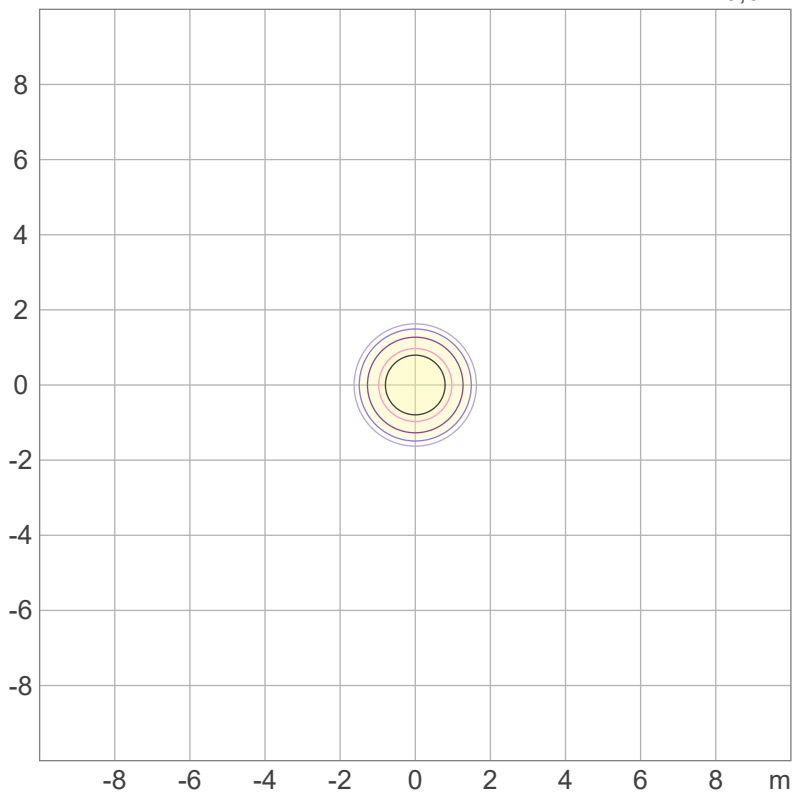

Mounting height: 10 meters (33 feet)

3%	36,7 lx
5%	61,2 lx
10%	122 lx
30%	367 lx
50%	612 lx

Conditions:

Number of c-planes: 2

Lux at center: 1224 lx

*Lux distribution on a surface when lamp is mounted at 10 meters from the surface.*



Total lumen output:

8883 lm

Peak candela output:

10283 cd

Light quality:

CRI: 96,5

Color temperature:

3178 K

PRODUCT NAME:

ECLFRCTPM

MEASURAMENT CONDITIONS:

Beam angle:

Max Zoom

Target:

3200K - HB

Operator:

Salvatore Giglio

Date and time:

03/10/2023 10:42:00

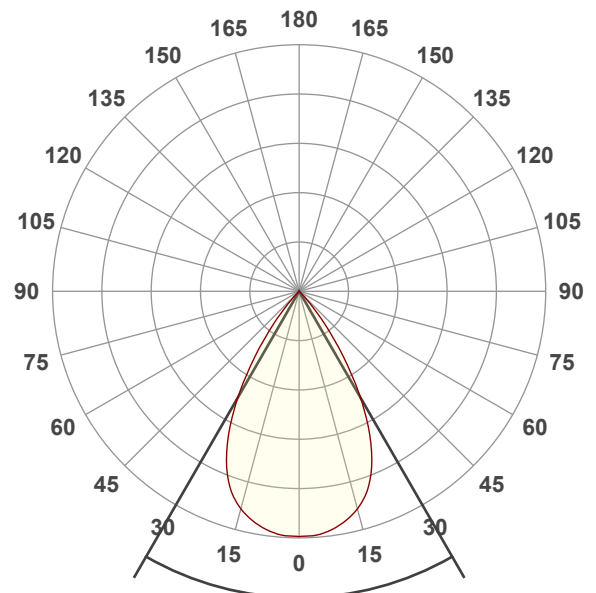

Spectra

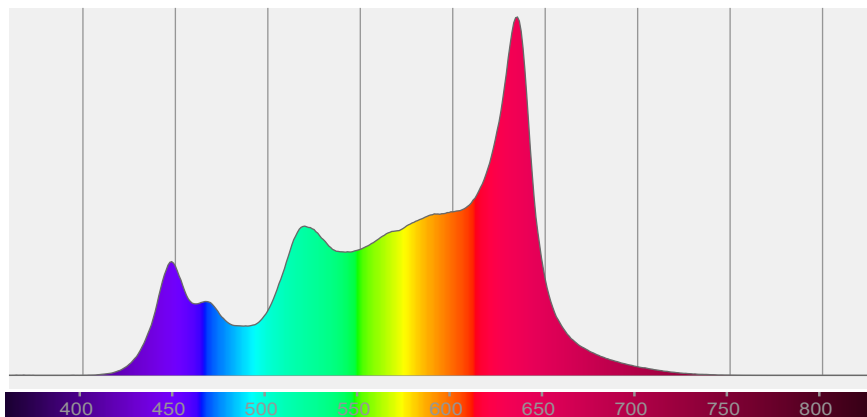

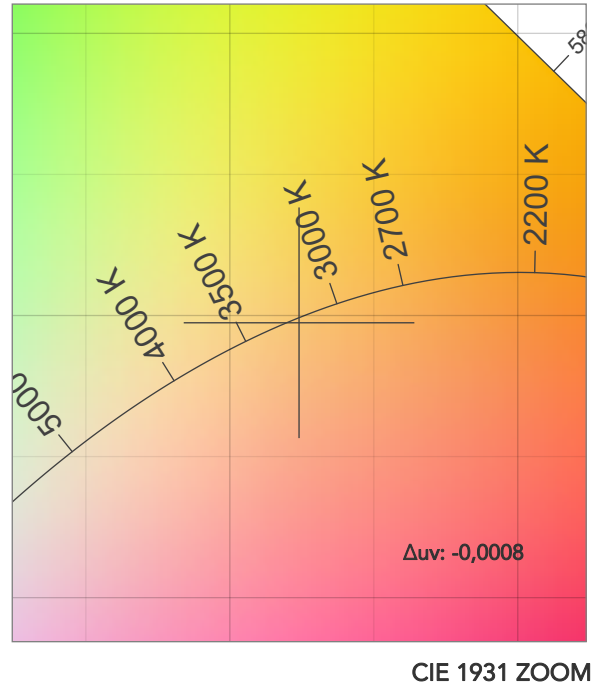
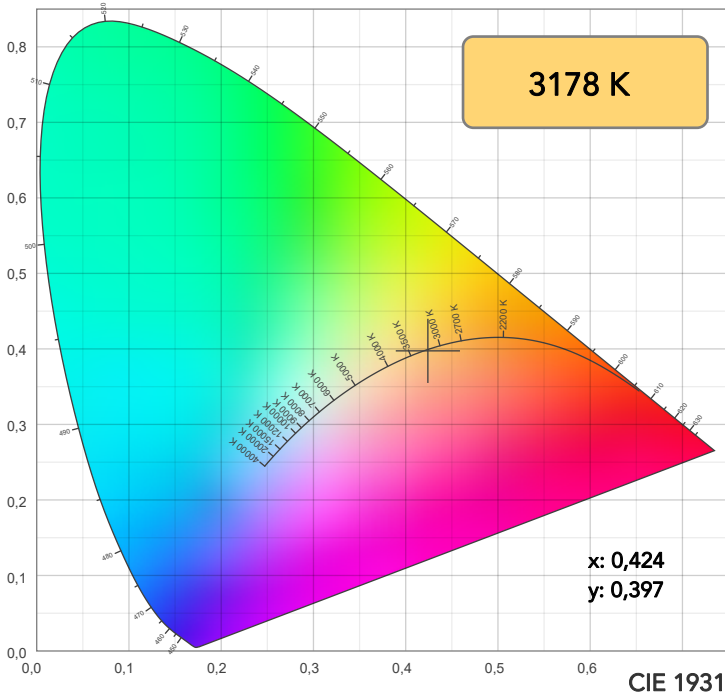

TM30: 93,8

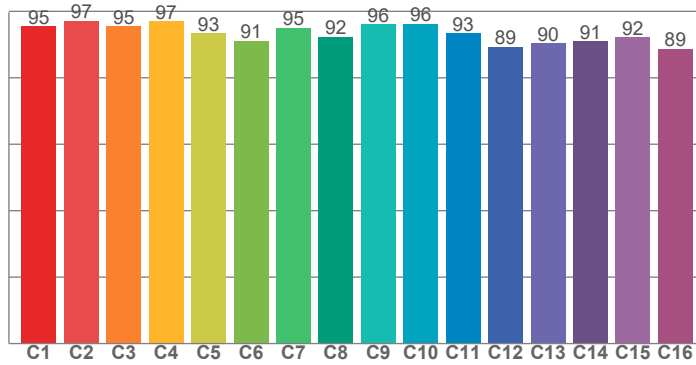

CRI: 96,5 (R1-R8)

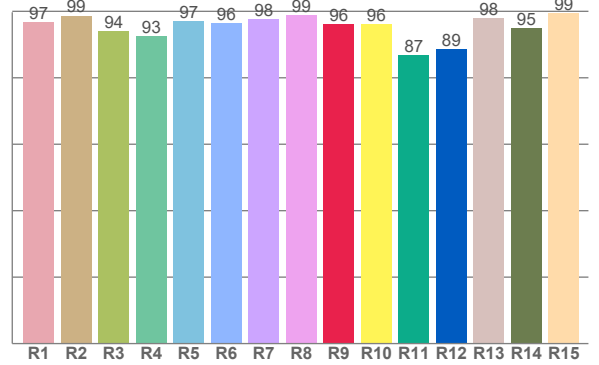

CRI R values, only R1-R8 are used to calculate final CRI value

R1	R2	R3	R4	R5	R6	R7	R8	R9	R10	R11	R12	R13	R14	R15
96,7	98,7	94,0	92,5	97,1	96,3	97,6	98,8	96,2	96,2	86,8	88,6	97,8	95,0	99,4

TM30 C values, 16 binned values out of total of 99 C values

C1	C2	C3	C4	C5	C6	C7	C8	C9	C10	C11	C12	C13	C14	C15	C16
95,4	97,2	95,4	96,9	93,4	91,0	95,0	92,3	96,1	96,3	93,4	89,2	90,3	90,9	92,1	88,7

CQS Q values

Q1	Q2	Q3	Q4	Q5	Q6	Q7	Q8	Q9	Q10	Q11	Q12	Q13	Q14	Q15
94,7	95,5	91,8	96,7	95,0	90,9	92,5	97,7	96,4	96,0	97,9	97,4	97,2	96,4	96,3

CQS: 94,9

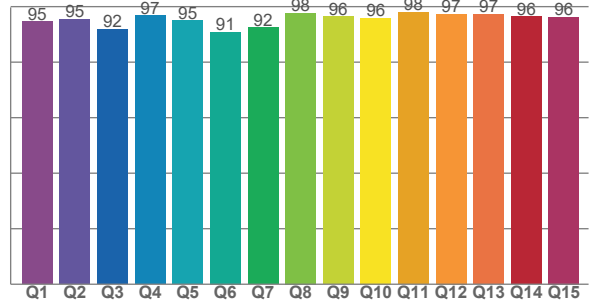

COLOR PARAMETERS

Color temperature	Color rendering index	Red component	Color fidelity	Color gamut	Color quality scale	Television lighting index	Color coordinate cie 1931	Color coordinate cie 1931	Color deviation from black body
CCT	CRI	CRI R9	TM30 Rf	TM30 Rg	CQS	TLCI	x	y	Δuv
3178 K	96,5	96,2	93,8	103,7	94,9	87	0,424	0,397	-0,0008

# TM30 DETAILS

**Rf 93,8**  
Fidelity index Rf

**Rg 103,7**  
Gammut index

Hue Bin	R <sub>f</sub>	Graphic shifts (%)	
		Chroma	Hue
1	95	-1%	-1%
2	97	0%	0%
3	95	0%	2%
4	97	0%	1%
5	93	1%	3%
6	91	5%	3%
7	95	3%	0%
8	92	4%	-2%
9	96	1%	0%
10	96	0%	1%
11	93	2%	4%
12	89	6%	-3%
13	90	3%	-6%
14	91	4%	-5%
15	92	1%	-4%
16	89	2%	-9%

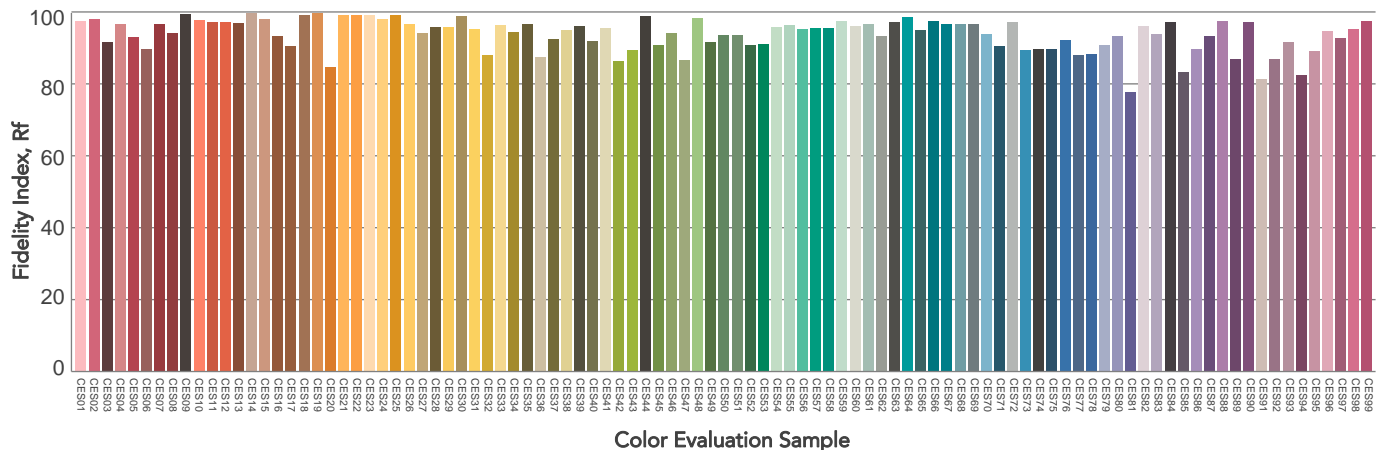
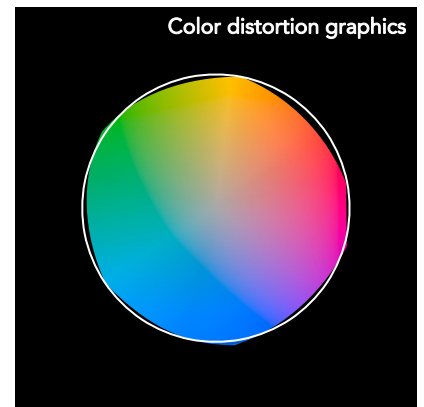
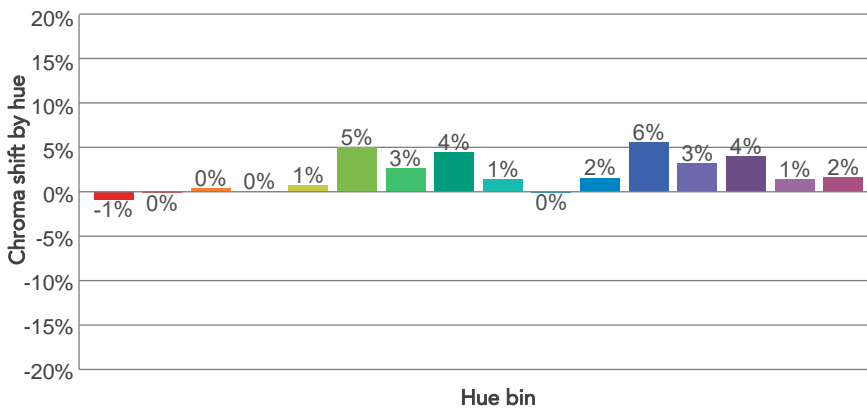
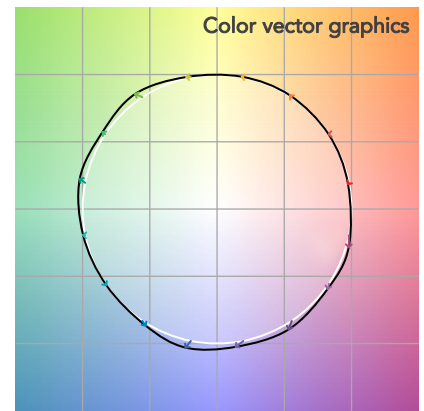
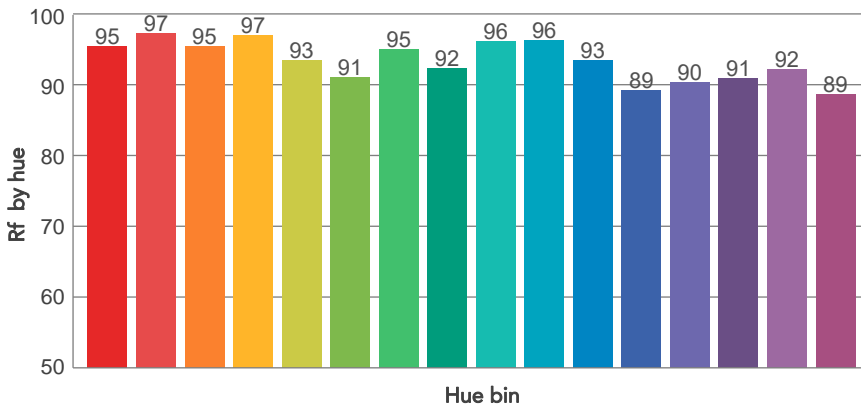
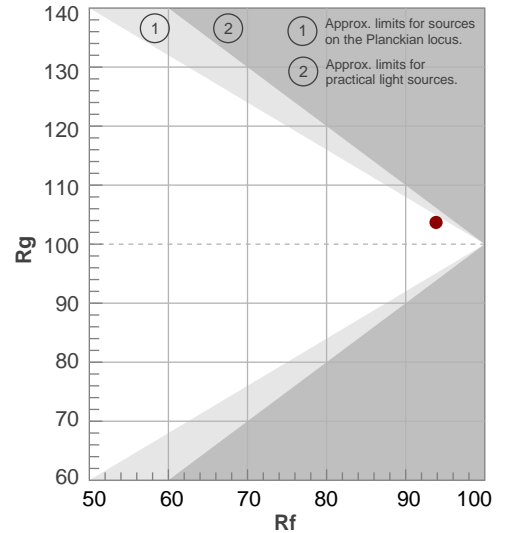

# BEAM DETAILS



Beam angle 50%	Field angle 10%	Cut off angle 2,5%	Intensity ratio in 120° cone	Intensity ratio in 90° cone
60°	81°	88,9°	100,0%	99,7%

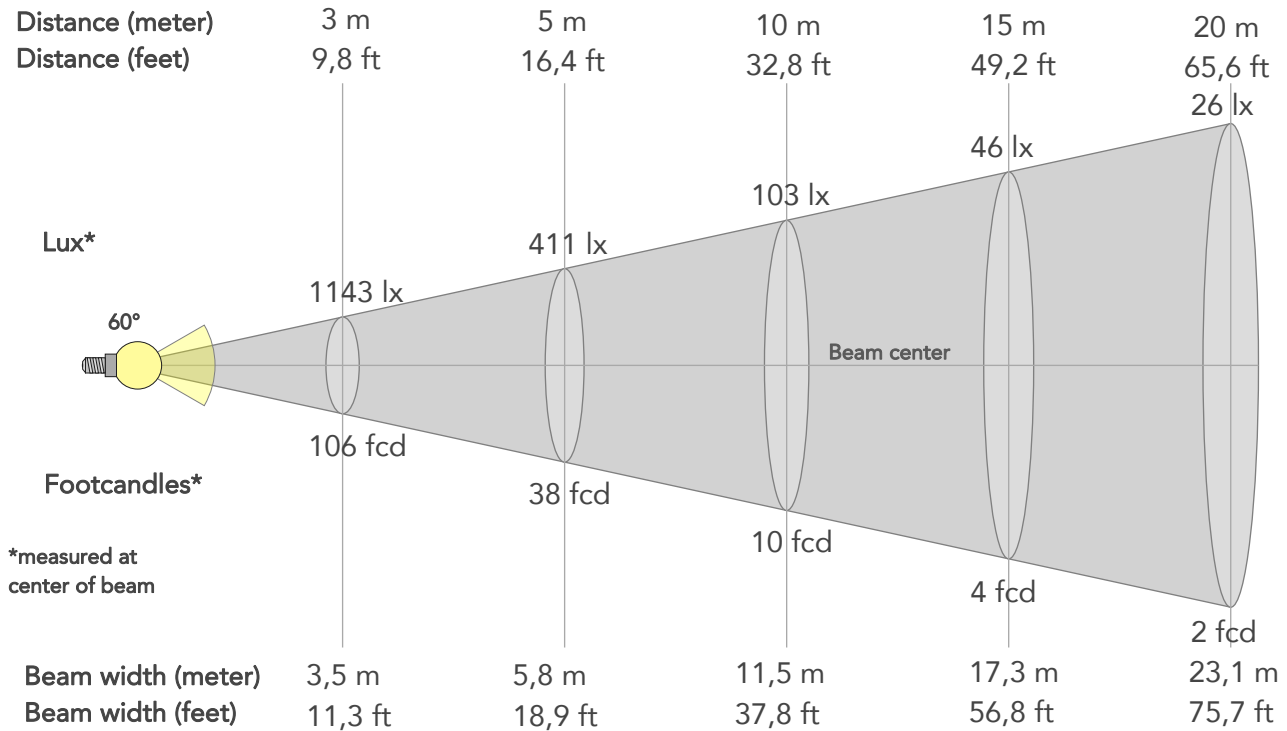

## BEAM INTENSITIES AND WIDTHS

Distance	1m	2m	3m	4m	5m	7,5m	10m	15m	20m	25m	30m	40m	50m
Distance	3,3ft	6,6ft	9,8ft	13,1ft	16,4ft	24,6ft	32,8ft	49,2ft	65,6ft	82ft	98,4ft	131,2ft	164ft
Lux	10283lx	2571lx	1143lx	643lx	411lx	183lx	103lx	46lx	26lx	16lx	11lx	6lx	4lx
Footcand.	955fcd	239fcd	106fcd	60fcd	38fcd	17fcd	10fcd	4fcd	2fcd	2fcd	1fcd	1fcd	0fcd
Beam wid.	1,2m	2,3m	3,5m	4,6m	5,8m	8,7m	11,5m	17,3m	23,1m	28,8m	34,6m	46,1m	57,7m
Beam wid.	3,8ft	7,6ft	11,3ft	15,1ft	18,9ft	28,4ft	37,8ft	56,8ft	75,7ft	94,6ft	113,5ft	151,4ft	189,2ft

## LINEAR DISTRIBUTION DIAGRAM

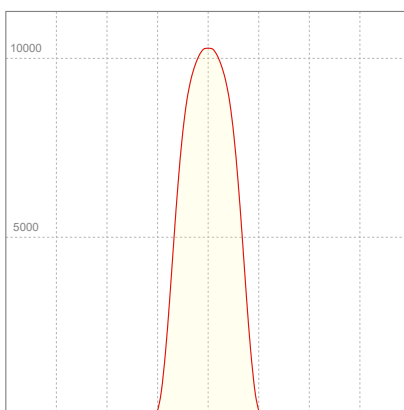

## ELECTRICAL SPECIFICATIONS

Input voltage	Input current	Input power	Effeciency
224V	1,23A	269,9W	33lm/W

## ISO CANDELA DIAGRAM

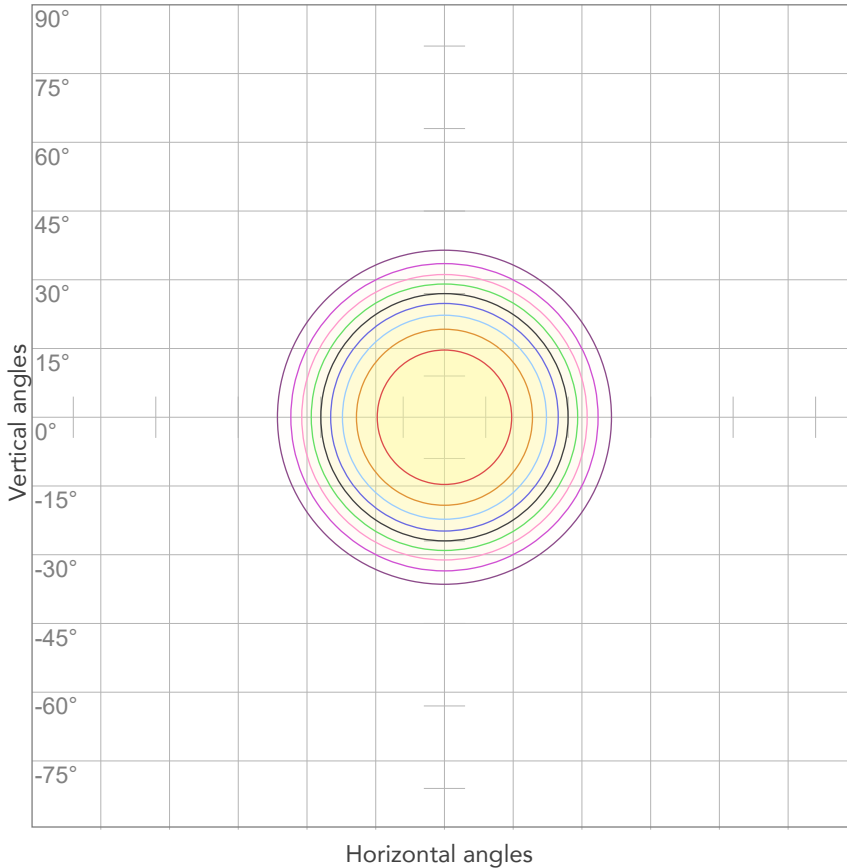

10%	1028 cd
20%	2057 cd
30%	3085 cd
40%	4113 cd
50%	5142 cd
60%	6170 cd
70%	7198 cd
80%	8227 cd

Conditions:

Number of c-planes: 2

Candela at center: 10283 cd

## ISO LUX DIAGRAM

MH: 10,0 m

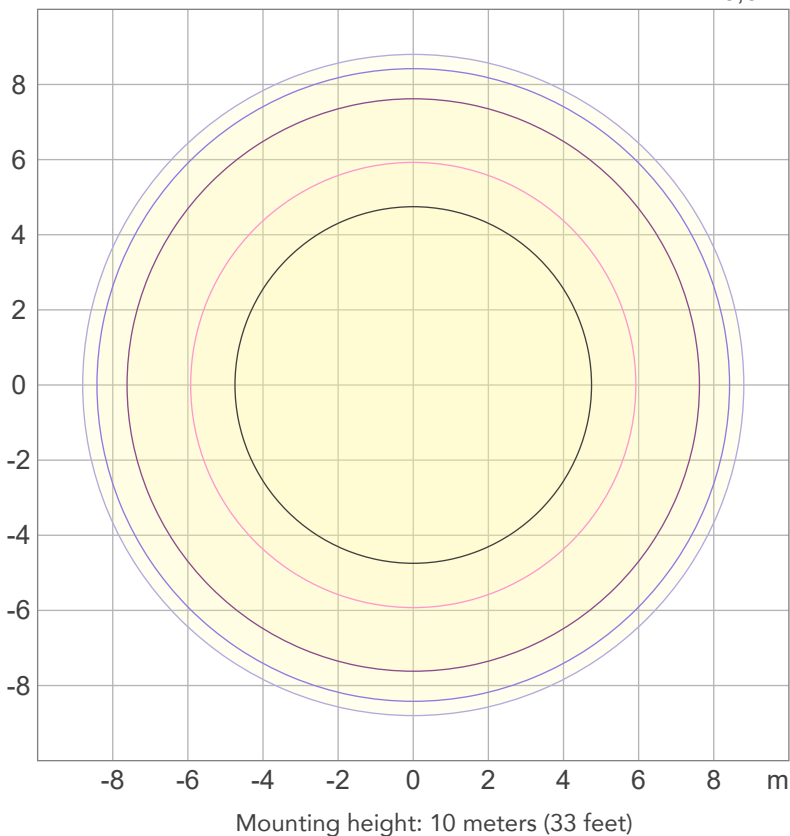

3%	3,08 lx
5%	5,14 lx
10%	10,3 lx
30%	30,8 lx
50%	51,4 lx

Conditions:

Number of c-planes: 2

Lux at center: 103 lx

*Lux distribution on a surface when lamp is mounted at 10 meters from the surface.*



Total lumen output:

6760 lm

Peak candela output:

35499 cd

Light quality:

CRI: 96,6

Color temperature:

3193 K

**PRODUCT NAME:**

ECLFRCTPM

**MEASURAMENT CONDITIONS:**

Beam angle:

Med Zoom

Target:

3200K - HB

Operator:

Salvatore Giglio

Date and time:

03/10/2023 11:53:41

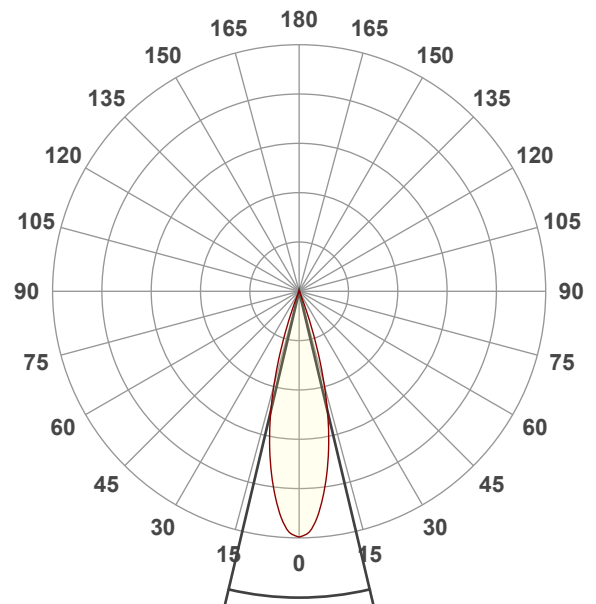

Beam angle 50%: 26,6°

Field angle 10%: 40,3°

Cut off angle 2.5%: 45,4°

Spectra

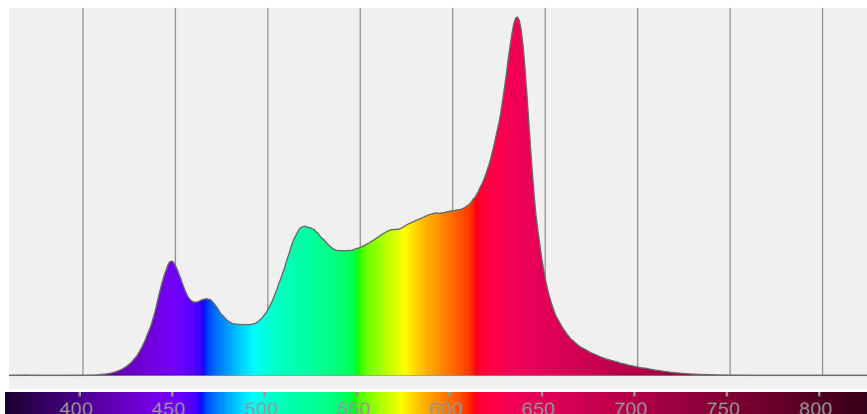



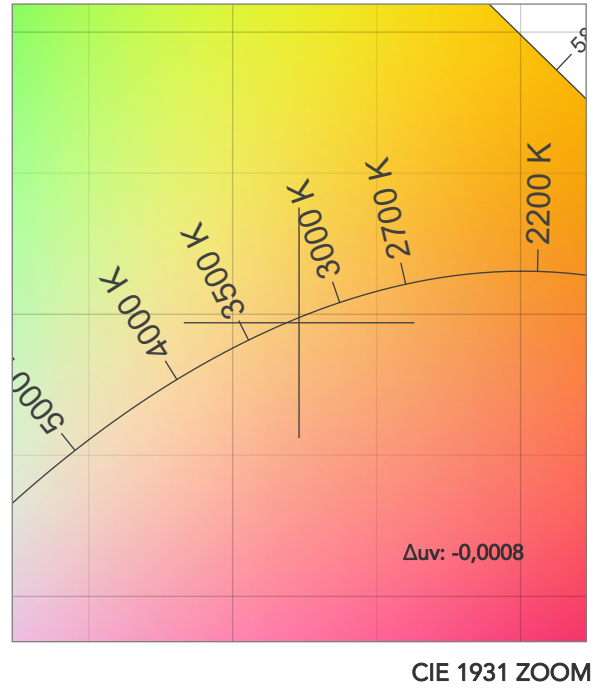
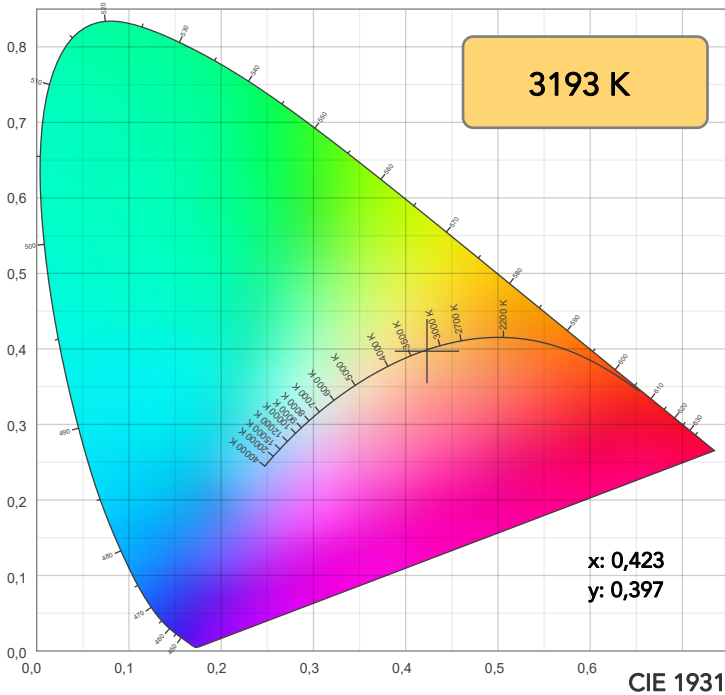

TM30: 93,9

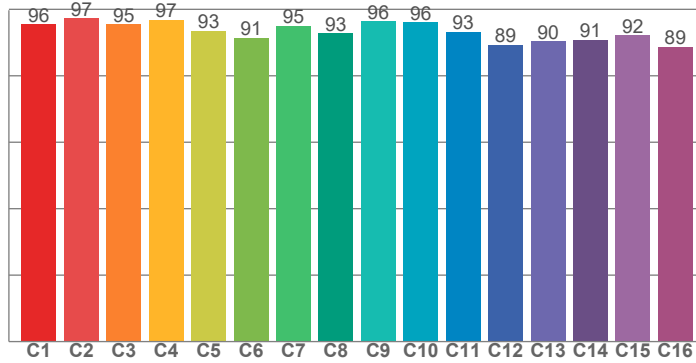

CRI: 96,6 (R1-R8)

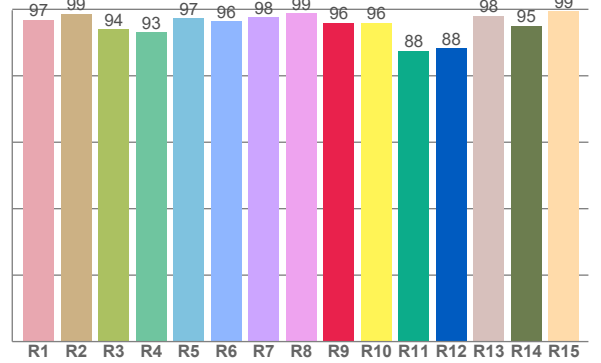

CRI R values, only R1-R8 are used to calculate final CRI value

R1	R2	R3	R4	R5	R6	R7	R8	R9	R10	R11	R12	R13	R14	R15
96,9	98,7	94,0	93,0	97,4	96,5	97,7	98,9	96,0	96,0	87,6	88,2	98,0	95,0	99,5

TM30 C values, 16 binned values out of total of 99 C values

C1	C2	C3	C4	C5	C6	C7	C8	C9	C10	C11	C12	C13	C14	C15	C16
95,5	97,3	95,4	96,9	93,5	91,4	95,1	92,8	96,4	96,0	93,2	89,3	90,3	90,9	92,2	88,6

CQS Q values

Q1	Q2	Q3	Q4	Q5	Q6	Q7	Q8	Q9	Q10	Q11	Q12	Q13	Q14	Q15
94,7	95,5	91,7	96,3	95,6	91,5	92,6	97,7	96,5	95,9	98,2	97,7	97,4	96,5	96,3

CQS: 95,0

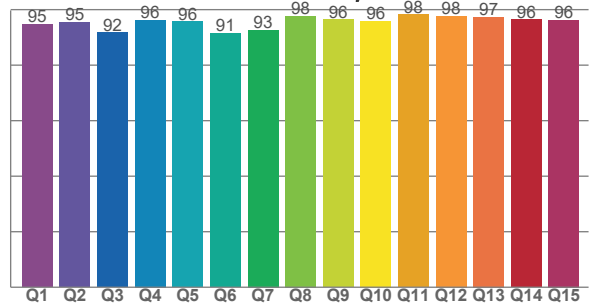

COLOR PARAMETERS

Color temperature	Color rendering index	Red component	Color fidelity	Color gamut	Color quality scale	Television lighting index	Color coordinate cie 1931	Color coordinate cie 1931	Color deviation from black body
CCT	CRI	CRI R9	TM30 Rf	TM30 Rg	CQS	TLCI	x	y	Δuv
3193 K	96,6	96,0	93,9	103,5	95,0	88	0,423	0,397	-0,0008

# TM30 DETAILS

**Rf 93,9**  
Fidelity index Rf

**Rg 103,5**  
Gammut index

Hue Bin	R <sub>f</sub>	Graphic shifts (%)	
		Chroma	Hue
1	96	-1%	-1%
2	97	0%	0%
3	95	0%	2%
4	97	0%	1%
5	93	0%	3%
6	91	5%	3%
7	95	2%	0%
8	93	4%	-2%
9	96	1%	0%
10	96	0%	2%
11	93	2%	4%
12	89	6%	-3%
13	90	3%	-6%
14	91	4%	-5%
15	92	1%	-4%
16	89	2%	-9%

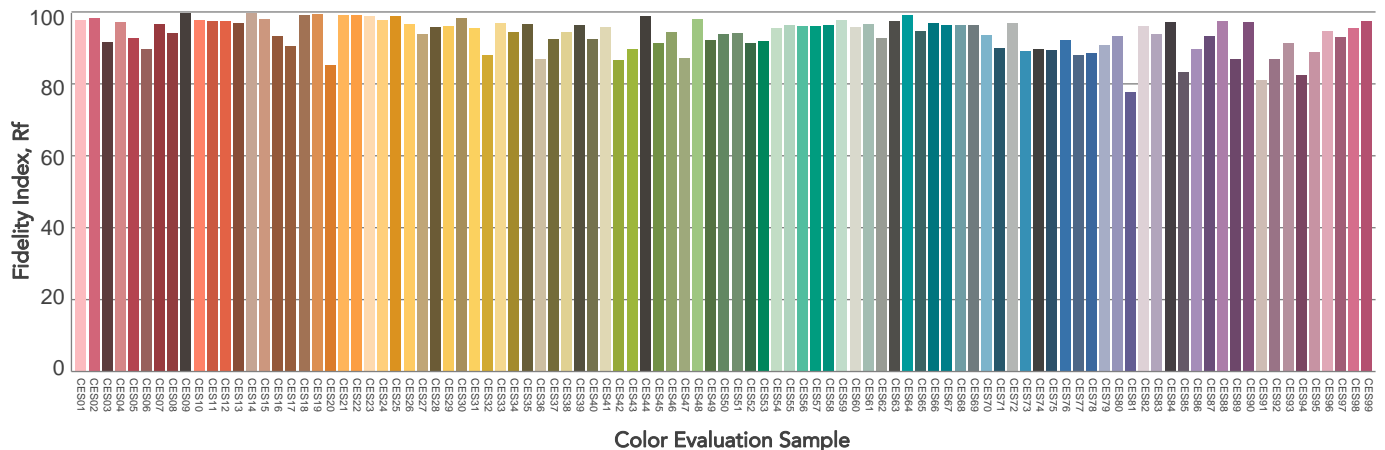
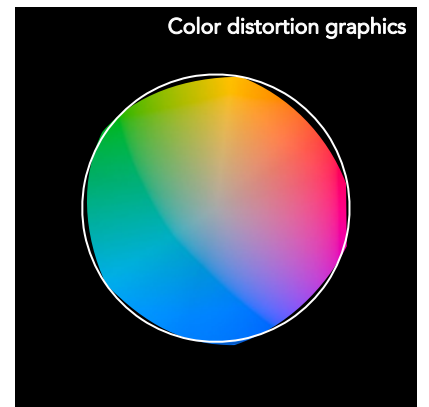
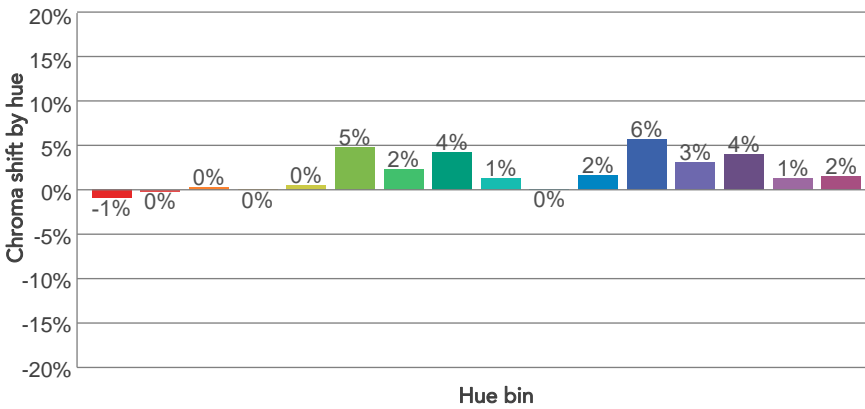
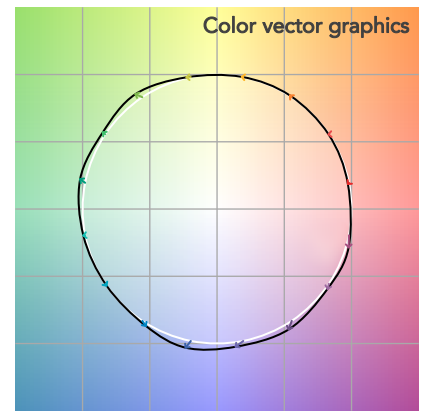
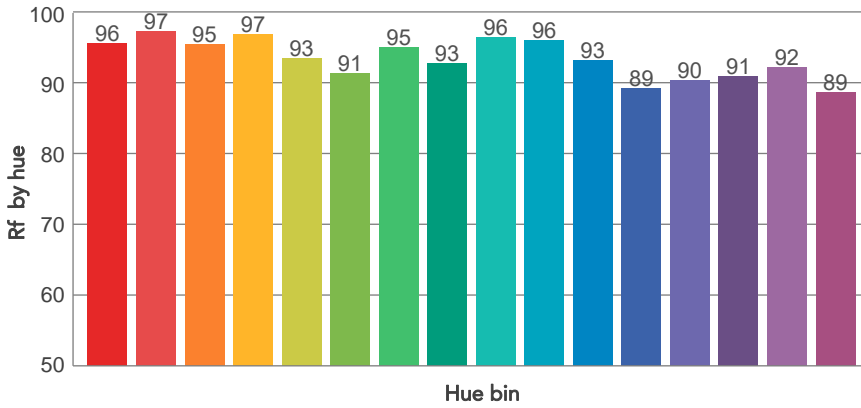
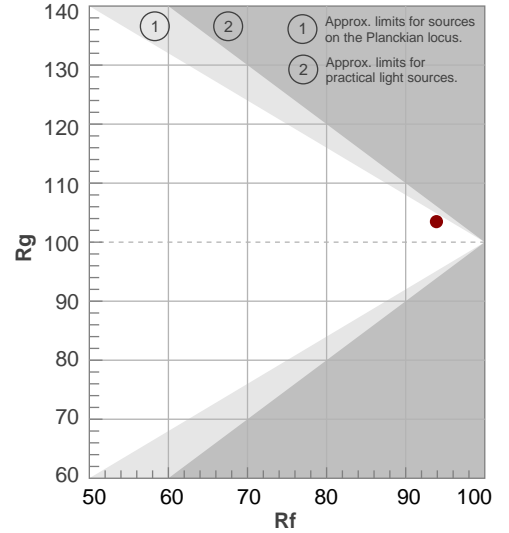

# BEAM DETAILS



Beam angle 50%	Field angle 10%	Cut off angle 2,5%	Intensity ratio in 120° cone	Intensity ratio in 90° cone
26,6°	40,3°	45,4°	100,0%	100,0%

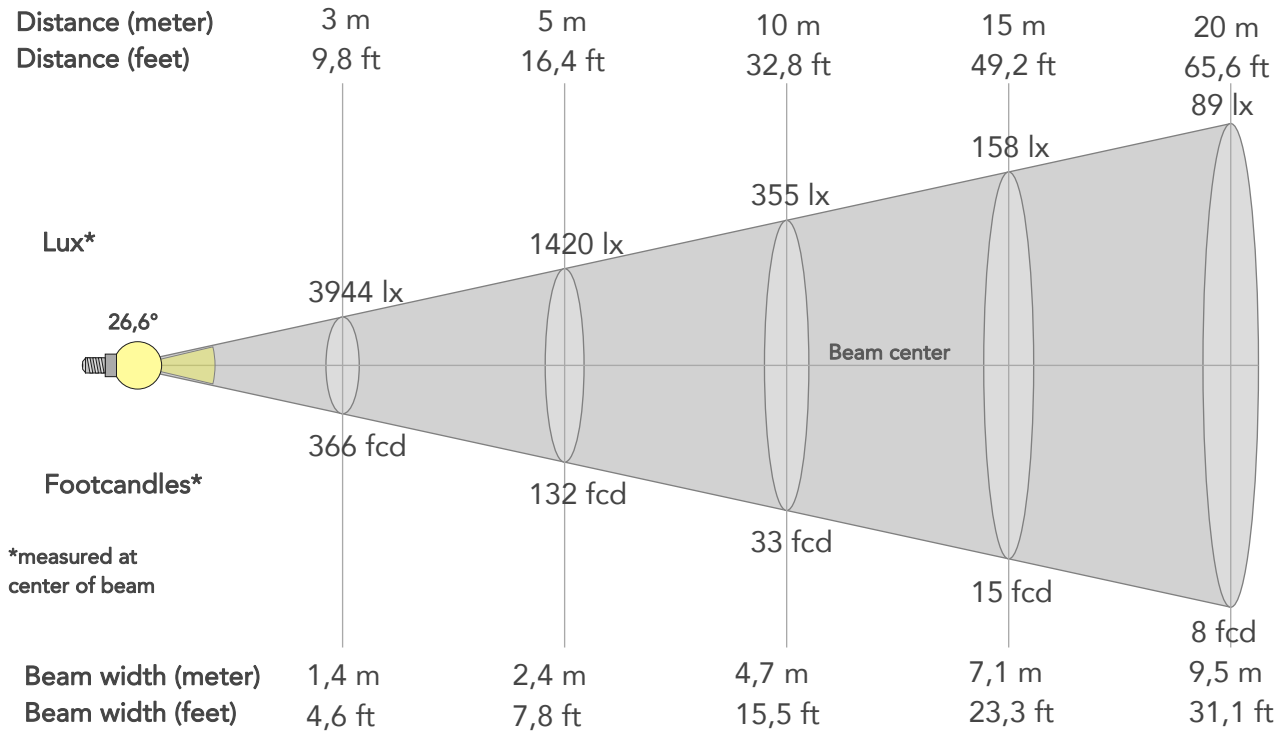

## BEAM INTENSITIES AND WIDTHS

Distance	1m	2m	3m	4m	5m	7,5m	10m	15m	20m	25m	30m	40m	50m
Distance	3,3ft	6,6ft	9,8ft	13,1ft	16,4ft	24,6ft	32,8ft	49,2ft	65,6ft	82ft	98,4ft	131,2ft	164ft
Lux	35499lx	8875lx	3944lx	2219lx	1420lx	631lx	355lx	158lx	89lx	57lx	39lx	22lx	14lx
Footcand.	3298fcd	824fcd	366fcd	206fcd	132fcd	59fcd	33fcd	15fcd	8fcd	5fcd	4fcd	2fcd	1fcd
Beam wid.	0,5m	0,9m	1,4m	1,9m	2,4m	3,6m	4,7m	7,1m	9,5m	11,8m	14,2m	18,9m	23,7m
Beam wid.	1,6ft	3,1ft	4,6ft	6,2ft	7,8ft	11,6ft	15,5ft	23,3ft	31,1ft	38,8ft	46,6ft	62,1ft	77,6ft

## LINEAR DISTRIBUTION DIAGRAM

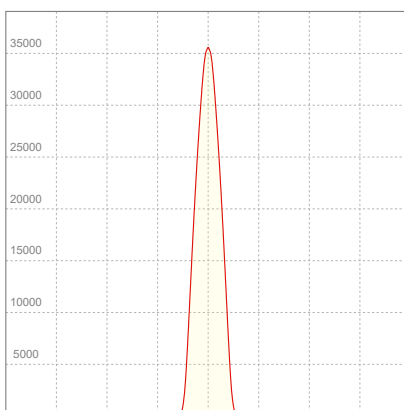

## ELECTRICAL SPECIFICATIONS

Input voltage	Input current	Input power	Effeciency
224V	1,23A	271,1W	25lm/W

## ISO CANDELA DIAGRAM

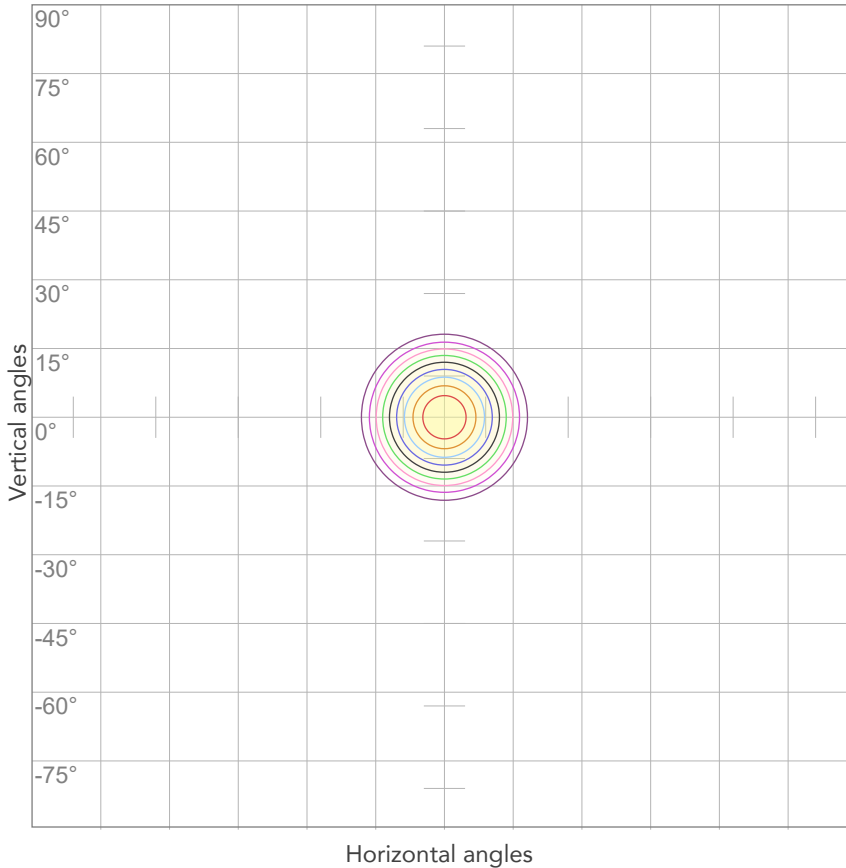

10%	3550 cd
20%	7100 cd
30%	10650 cd
40%	14199 cd
50%	17749 cd
60%	21299 cd
70%	24849 cd
80%	28399 cd

Conditions:

Number of c-planes: 2

Candela at center: 35499 cd

## ISO LUX DIAGRAM

MH: 10,0 m

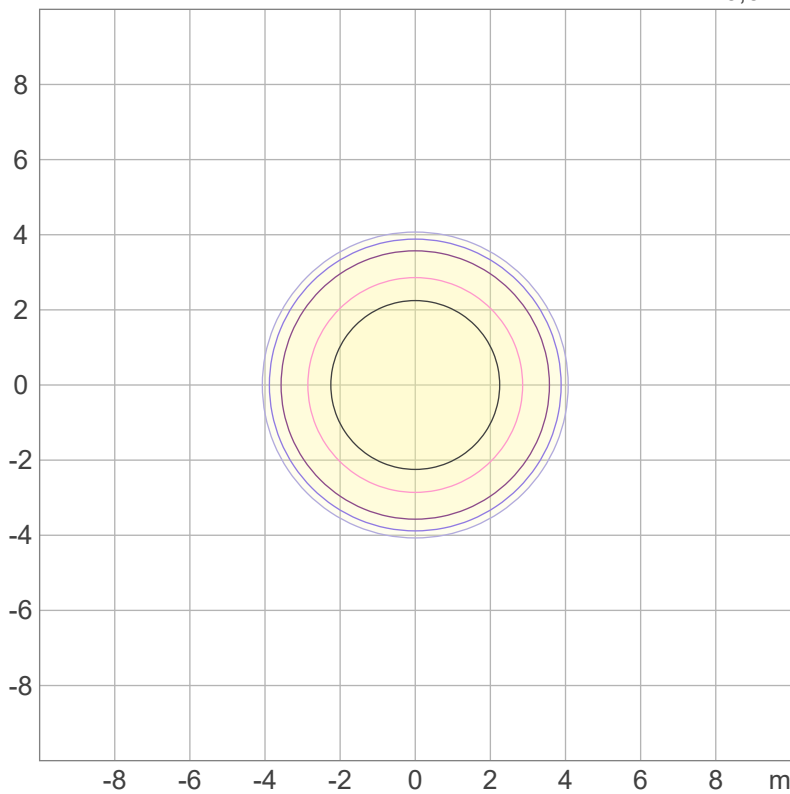

Mounting height: 10 meters (33 feet)

3%	10,6 lx
5%	17,7 lx
10%	35,5 lx
30%	106 lx
50%	177 lx

Conditions:

Number of c-planes: 2

Lux at center: 355 lx

*Lux distribution on a surface when lamp is mounted at 10 meters from the surface.*



Total lumen output:

3476 lm

Peak candela output:

131026 cd

Light quality:

CRI: 96,8

Color temperature:

3172 K

PRODUCT NAME:

ECLFRCTPM

MEASURAMENT CONDITIONS:

Beam angle:

Min Zoom

Target:

3200K - HB

Operator:

Salvatore Giglio

Date and time:

03/10/2023 11:38:29

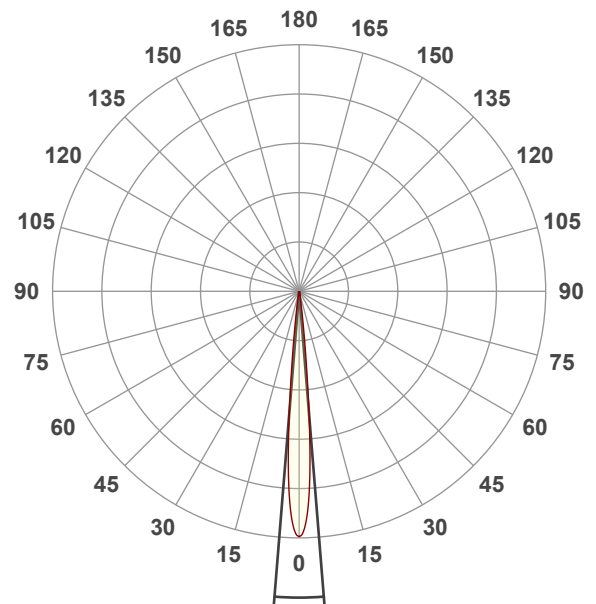

Spectra

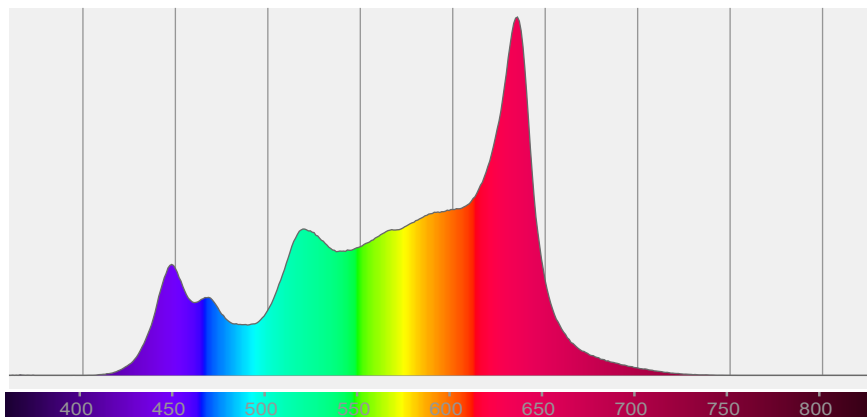

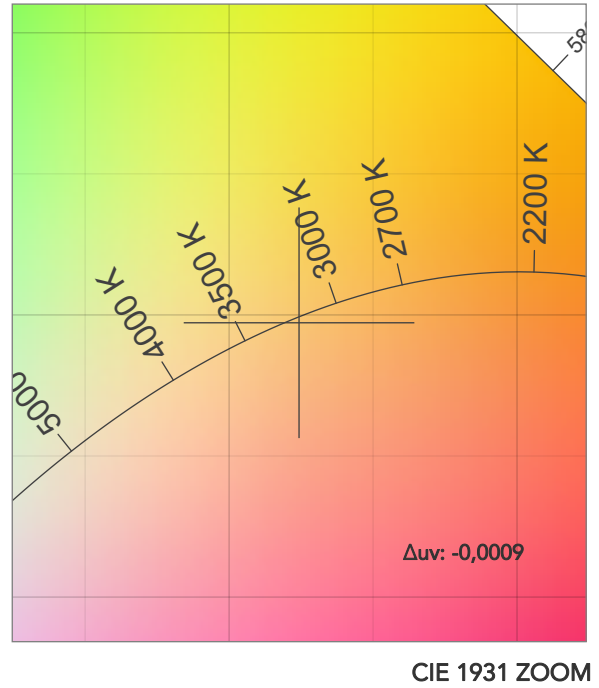
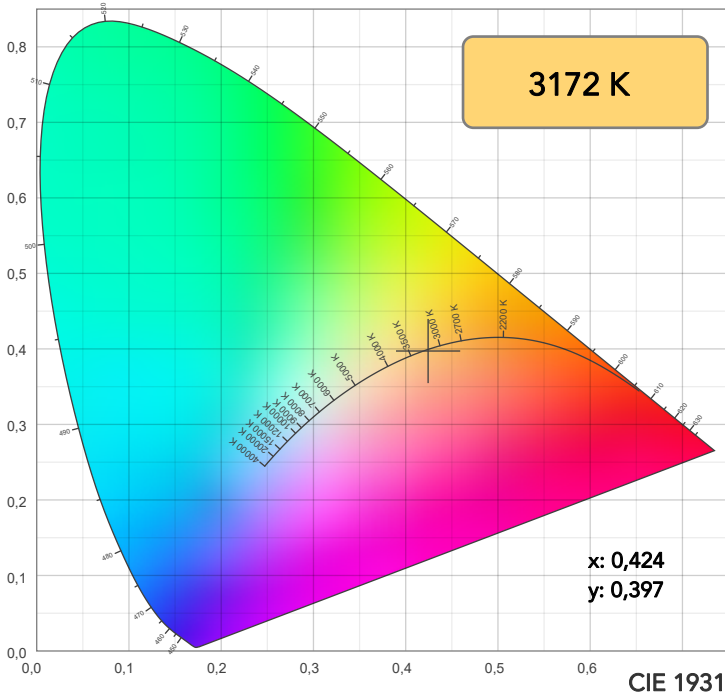

TM30: 93,8

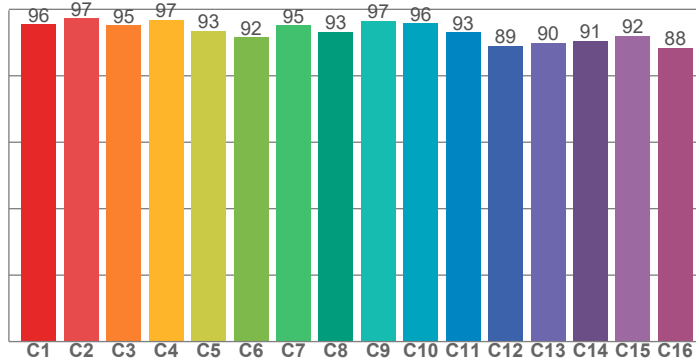

CRI: 96,8 (R1-R8)

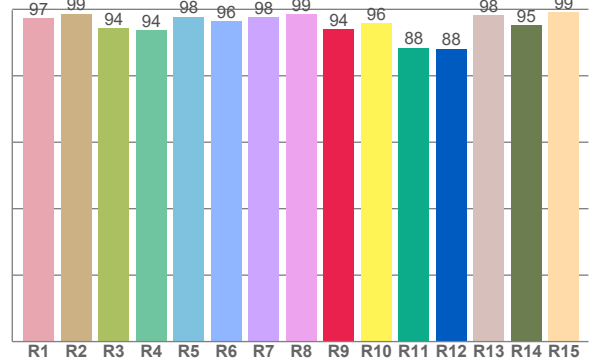

CRI R values, only R1-R8 are used to calculate final CRI value

R1	R2	R3	R4	R5	R6	R7	R8	R9	R10	R11	R12	R13	R14	R15
97,3	98,7	94,3	93,7	97,8	96,4	97,5	98,6	94,1	95,9	88,4	88,1	98,3	95,1	99,2

TM30 C values, 16 binned values out of total of 99 C values

C1	C2	C3	C4	C5	C6	C7	C8	C9	C10	C11	C12	C13	C14	C15	C16
95,5	97,3	95,2	96,8	93,5	91,6	95,2	93,2	96,6	95,7	93,0	89,0	89,9	90,6	92,1	88,5

CQS Q values

Q1	Q2	Q3	Q4	Q5	Q6	Q7	Q8	Q9	Q10	Q11	Q12	Q13	Q14	Q15
94,2	95,2	91,6	95,8	96,1	91,9	92,5	97,4	96,6	95,8	98,4	98,0	97,7	96,3	95,7

CQS: 94,9

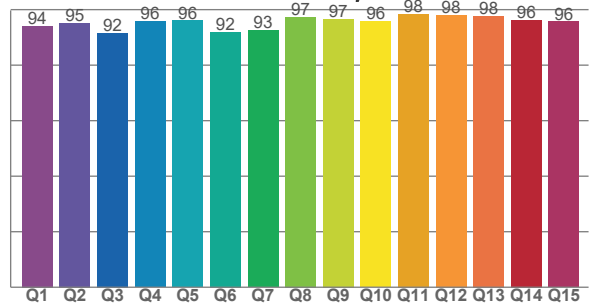

COLOR PARAMETERS

Color temperature	Color rendering index	Red component	Color fidelity	Color gamut	Color quality scale	Television lighting index	Color coordinate cie 1931	Color coordinate cie 1931	Color deviation from black body
CCT	CRI	CRI R9	TM30 Rf	TM30 Rg	CQS	TLCI	x	y	Δuv
3172 K	96,8	94,1	93,8	103,2	94,9	87	0,424	0,397	-0,0009

# TM30 DETAILS

**Rf 93,8**  
Fidelity index Rf

**Rg 103,2**  
Gammut index

Hue Bin	R <sub>f</sub>	Graphic shifts (%)	
		Chroma	Hue
1	96	-1%	-1%
2	97	0%	0%
3	95	0%	2%
4	97	0%	1%
5	93	0%	3%
6	92	5%	3%
7	95	2%	0%
8	93	4%	-2%
9	97	1%	0%
10	96	0%	2%
11	93	2%	4%
12	89	6%	-3%
13	90	3%	-7%
14	91	4%	-6%
15	92	1%	-4%
16	88	1%	-9%

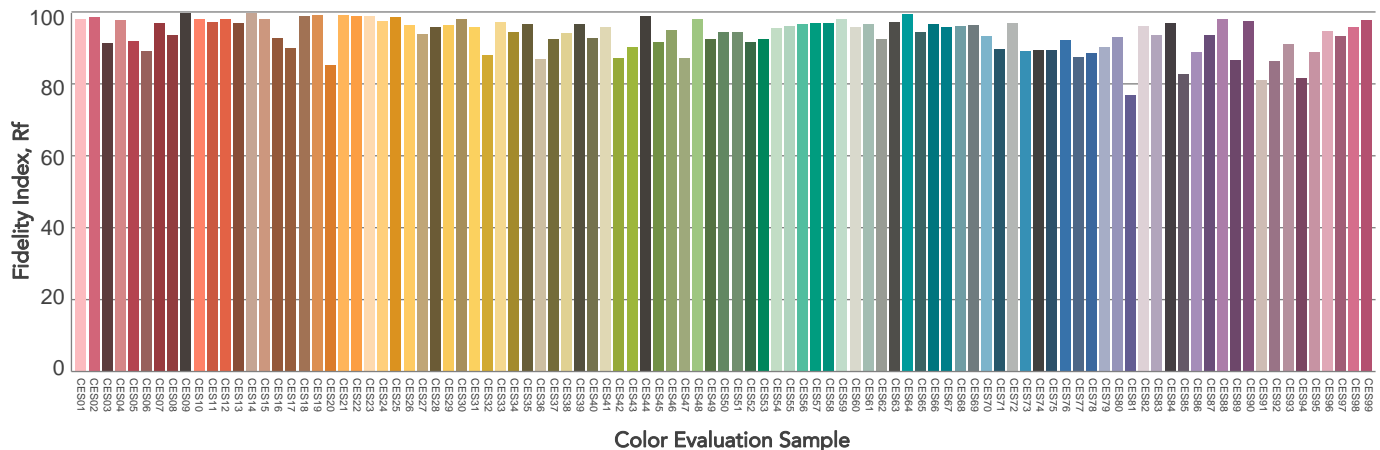
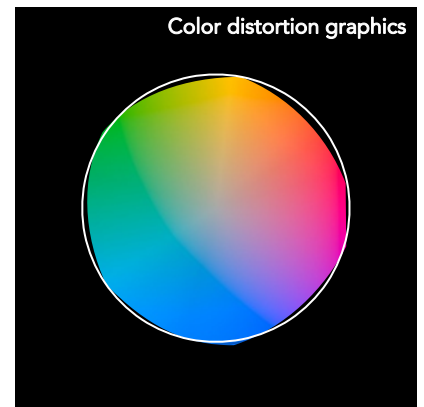
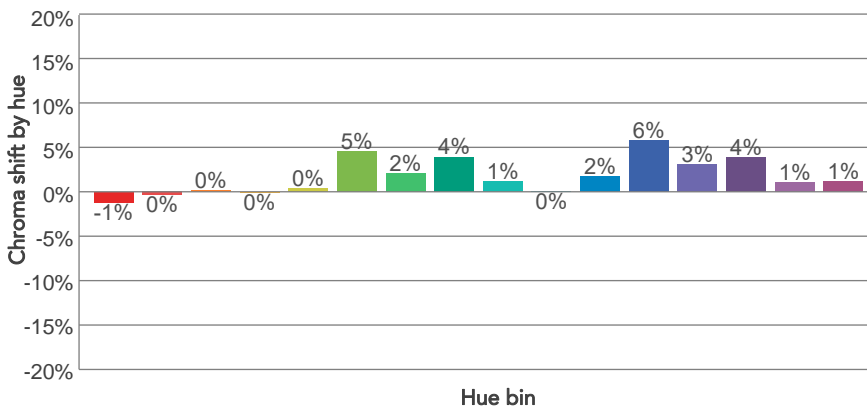
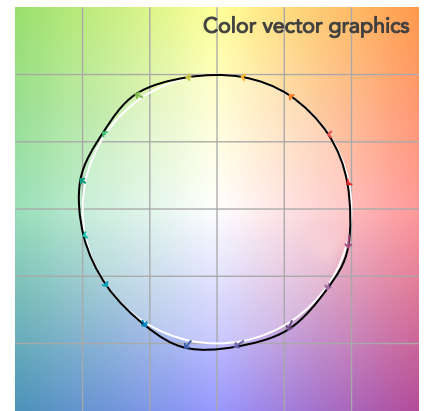
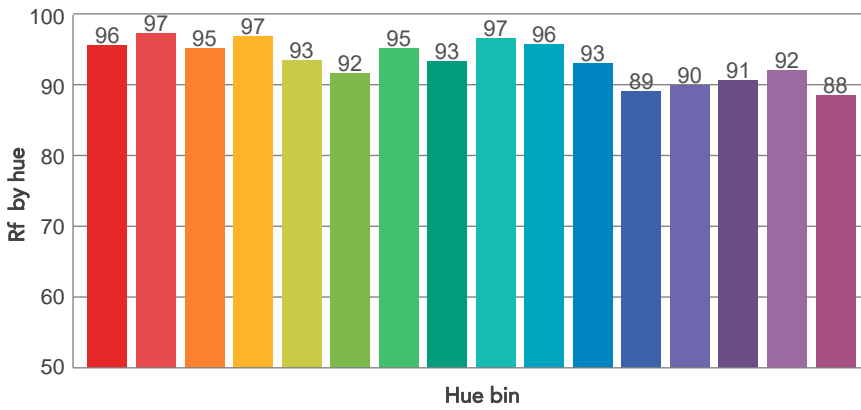
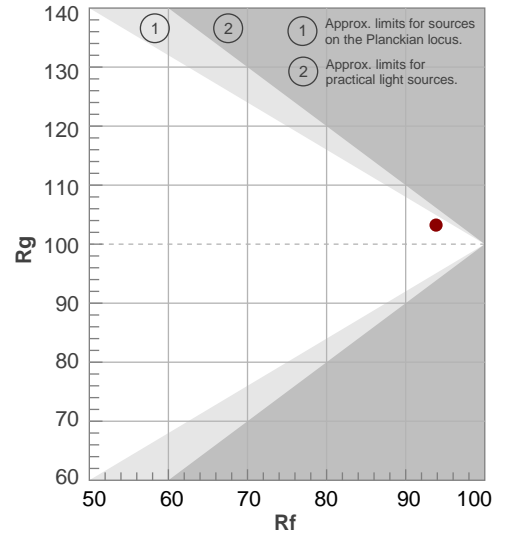

# BEAM DETAILS



Beam angle 50%	Field angle 10%	Cut off angle 2,5%	Intensity ratio in 120° cone	Intensity ratio in 90° cone
9,2°	15°	19,7°	100,0%	100,0%

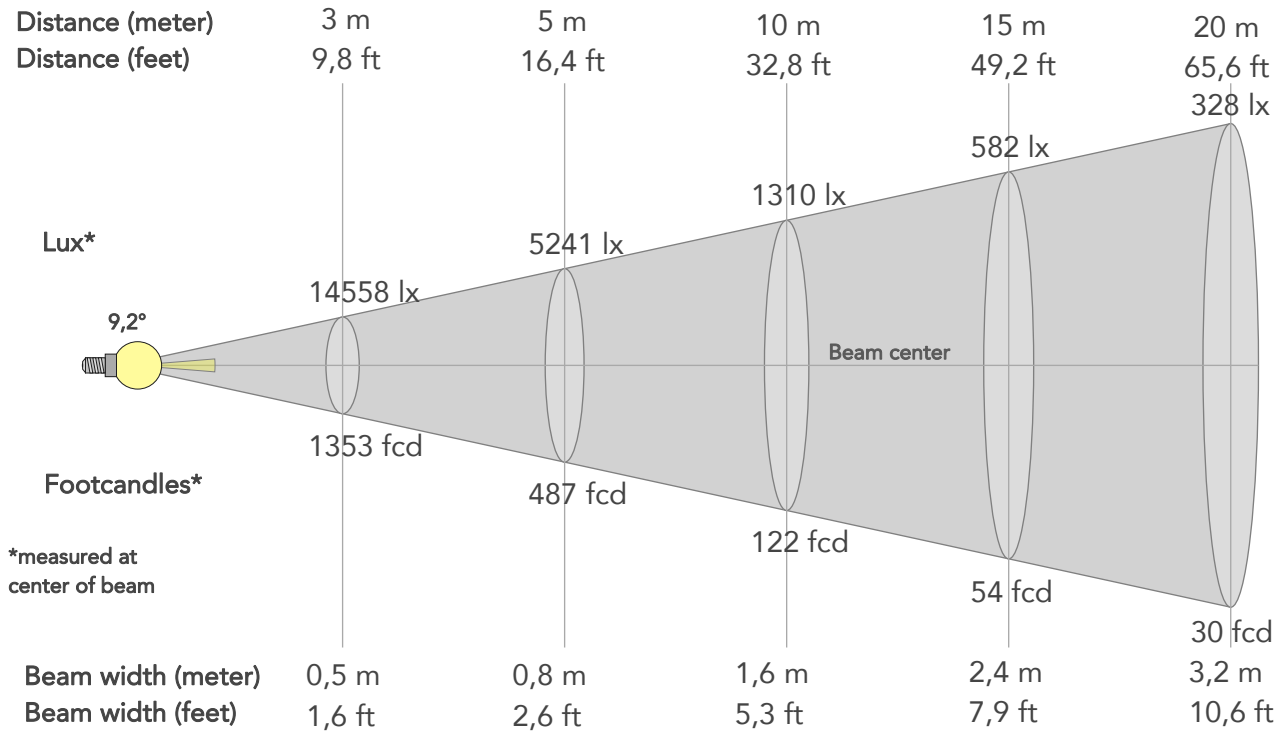

## BEAM INTENSITIES AND WIDTHS

Distance	1m	2m	3m	4m	5m	7,5m	10m	15m	20m	25m	30m	40m	50m
Distance	3,3ft	6,6ft	9,8ft	13,1ft	16,4ft	24,6ft	32,8ft	49,2ft	65,6ft	82ft	98,4ft	131,2ft	164ft
Lux	131026lx	32757lx	14558lx	8189lx	5241lx	2329lx	1310lx	582lx	328lx	210lx	146lx	82lx	52lx
Footcand.	12173fcd	3043fcd	1353fcd	761fcd	487fcd	216fcd	122fcd	54fcd	30fcd	19fcd	14fcd	8fcd	5fcd
Beam wid.	0,2m	0,3m	0,5m	0,6m	0,8m	1,2m	1,6m	2,4m	3,2m	4m	4,8m	6,5m	8,1m
Beam wid.	0,5ft	1,1ft	1,6ft	2,1ft	2,6ft	4ft	5,3ft	7,9ft	10,6ft	13,2ft	15,9ft	21,2ft	26,5ft

## LINEAR DISTRIBUTION DIAGRAM

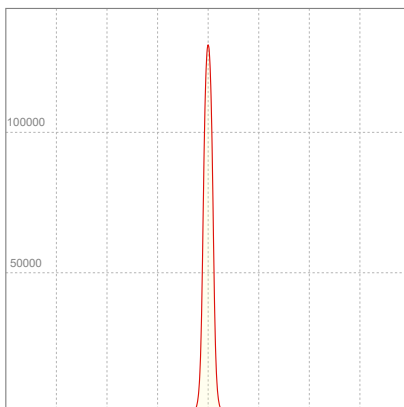

## ELECTRICAL SPECIFICATIONS

Input voltage	Input current	Input power	Effeciency
228V	1,21A	271,5W	13lm/W



## ISO CANDELA DIAGRAM

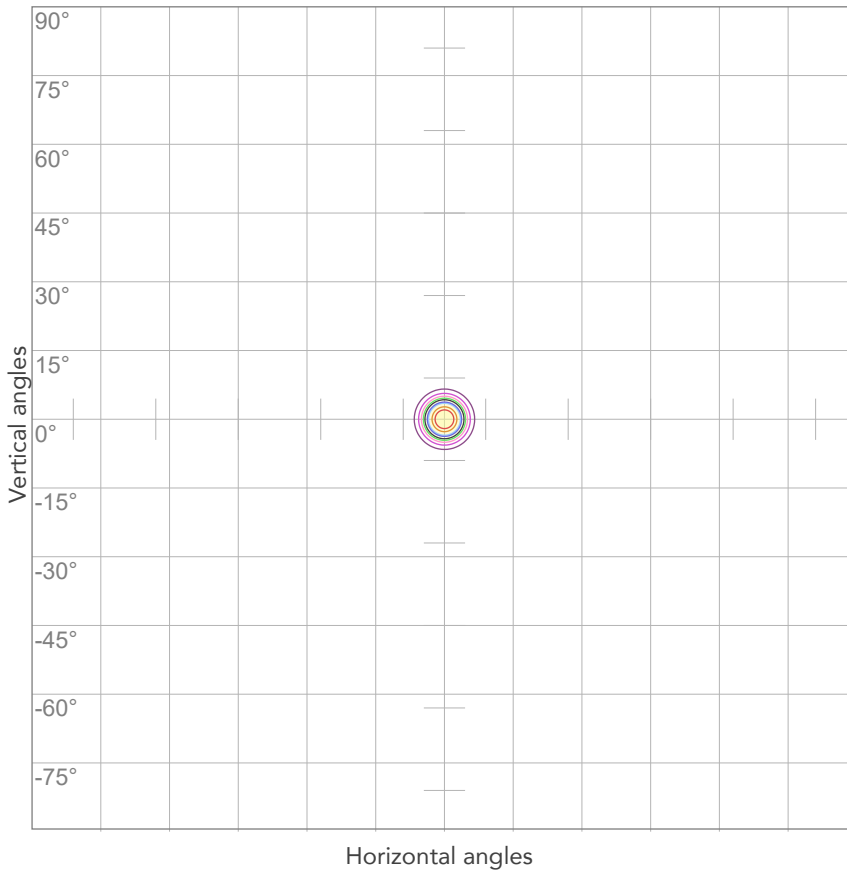

10%	13103 cd
20%	26205 cd
30%	39308 cd
40%	52410 cd
50%	65513 cd
60%	78616 cd
70%	91718 cd
80%	104821 cd

Conditions:

Number of c-planes: 2

Candela at center: 131026 cd

## ISO LUX DIAGRAM

MH: 10,0 m

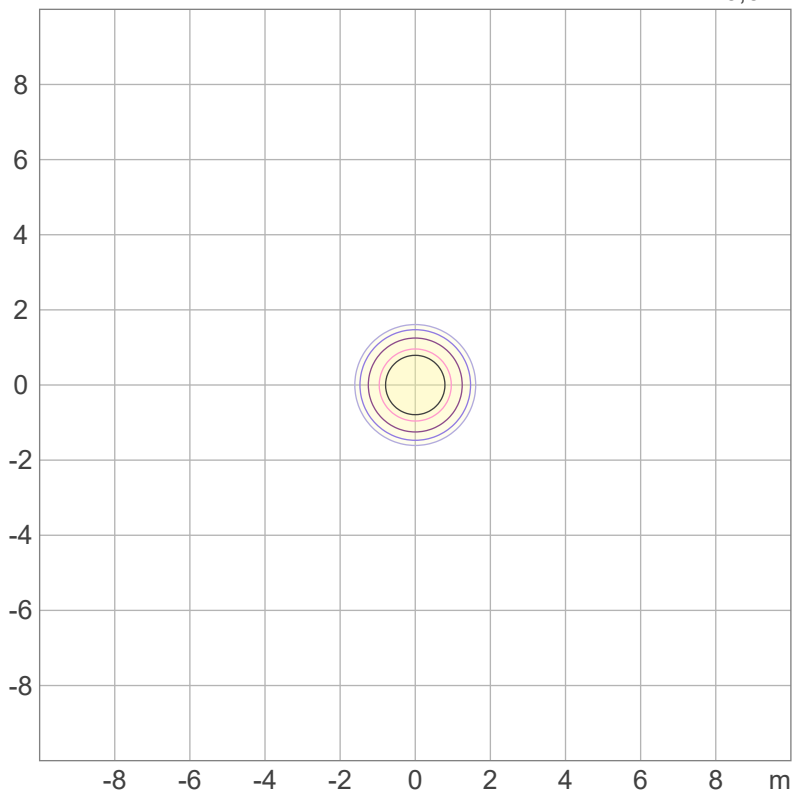

Mounting height: 10 meters (33 feet)

3%	39,3 lx
5%	65,5 lx
10%	131 lx
30%	393 lx
50%	655 lx

Conditions:

Number of c-planes: 2

Lux at center: 1310 lx

*Lux distribution on a surface when lamp is mounted at 10 meters from the surface.*



Total lumen output:

9827 lm

Peak candela output:

11271 cd

Light quality:

CRI: 91,3

Color temperature:

3976 K

PRODUCT NAME:

ECLFRCTPM

MEASURAMENT CONDITIONS:

Beam angle:

Max Zoom

Target:

4000K - HB

Operator:

Salvatore Giglio

Date and time:

03/10/2023 10:37:35

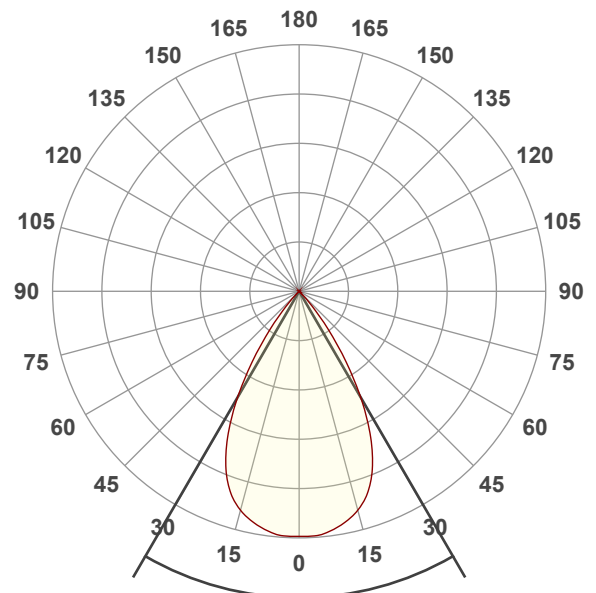

Spectra

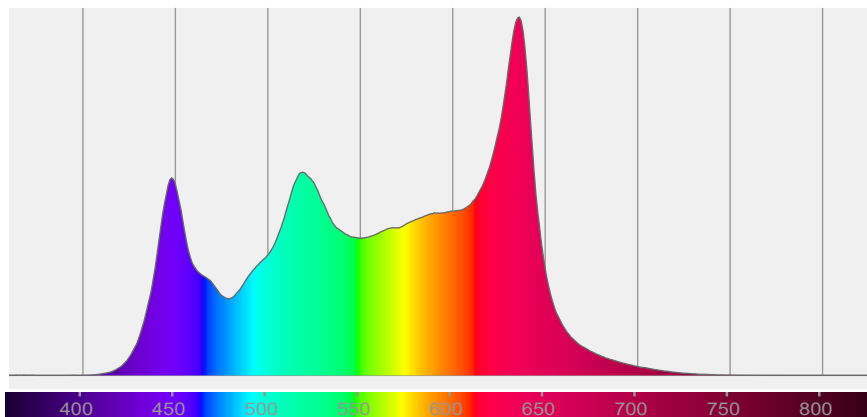

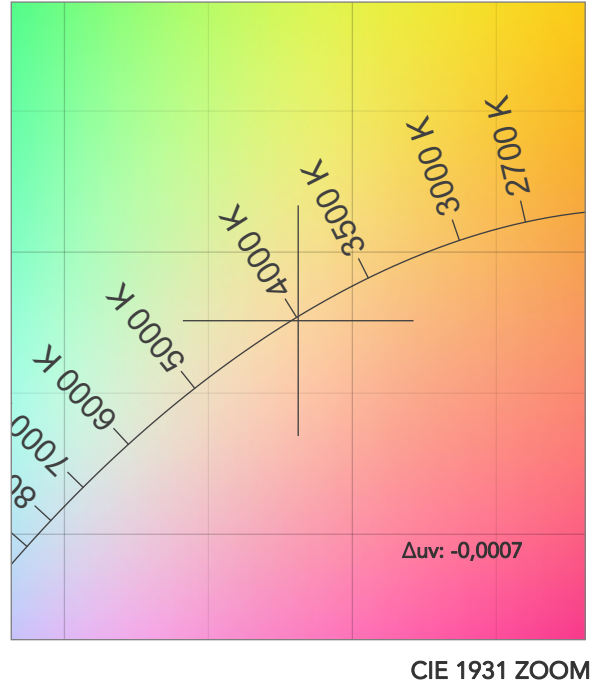
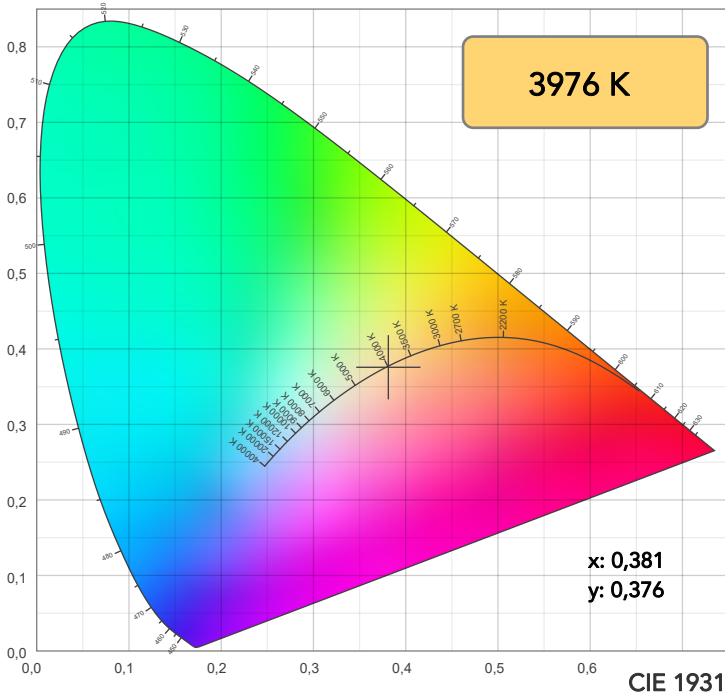

TM30: 92,6

CRI: 91,3 (R1-R8)

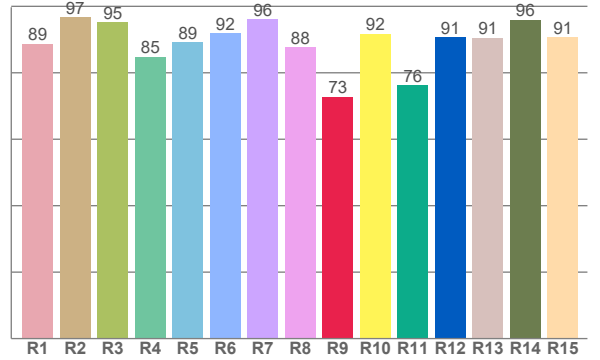
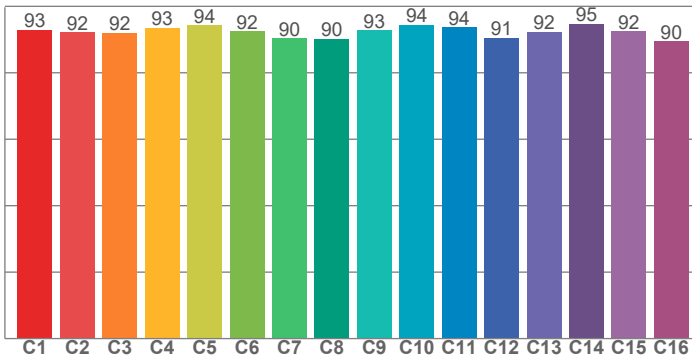

CRI R values, only R1-R8 are used to calculate final CRI value

R1	R2	R3	R4	R5	R6	R7	R8	R9	R10	R11	R12	R13	R14	R15
88,8	96,6	95,3	84,9	89,2	91,8	96,1	87,6	72,8	91,8	76,3	90,7	90,6	96,0	90,8

TM30 C values, 16 binned values out of total of 99 C values

C1	C2	C3	C4	C5	C6	C7	C8	C9	C10	C11	C12	C13	C14	C15	C16
93,0	92,1	92,0	93,5	94,3	92,4	90,3	90,1	92,8	94,5	93,7	90,6	92,2	94,7	92,4	89,5

CQS Q values

Q1	Q2	Q3	Q4	Q5	Q6	Q7	Q8	Q9	Q10	Q11	Q12	Q13	Q14	Q15
96,8	97,6	98,3	93,6	91,1	92,4	98,3	94,7	97,5	96,9	91,2	91,1	92,9	96,2	95,7

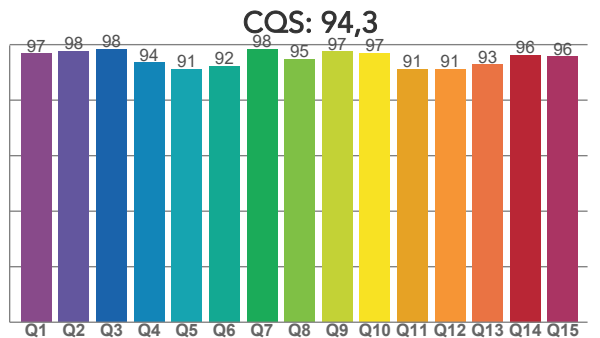

COLOR PARAMETERS

Color temperature	Color rendering index	Red component	Color fidelity	Color gamut	Color quality scale	Television lighting index	Color coordinate cie 1931	Color coordinate cie 1931	Color deviation from black body
CCT	CRI	CRI R9	TM30 Rf	TM30 Rg	CQS	TLCI	x	y	Δuv
3976 K	91,3	72,8	92,6	104,7	94,3	87	0,381	0,376	-0,0007

# TM30 DETAILS

**Rf 92,6**  
Fidelity index Rf

**Rg 104,7**  
Gammut index

Hue Bin	R <sub>f</sub>	Graphic shifts (%)	
		Chroma	Hue
1	93	3%	-1%
2	92	3%	-3%
3	92	1%	-3%
4	93	-2%	-4%
5	94	-2%	0%
6	92	3%	4%
7	90	5%	3%
8	90	5%	2%
9	93	5%	0%
10	94	2%	-2%
11	94	4%	0%
12	91	3%	-2%
13	92	2%	-5%
14	95	1%	3%
15	92	3%	-1%
16	90	4%	-3%

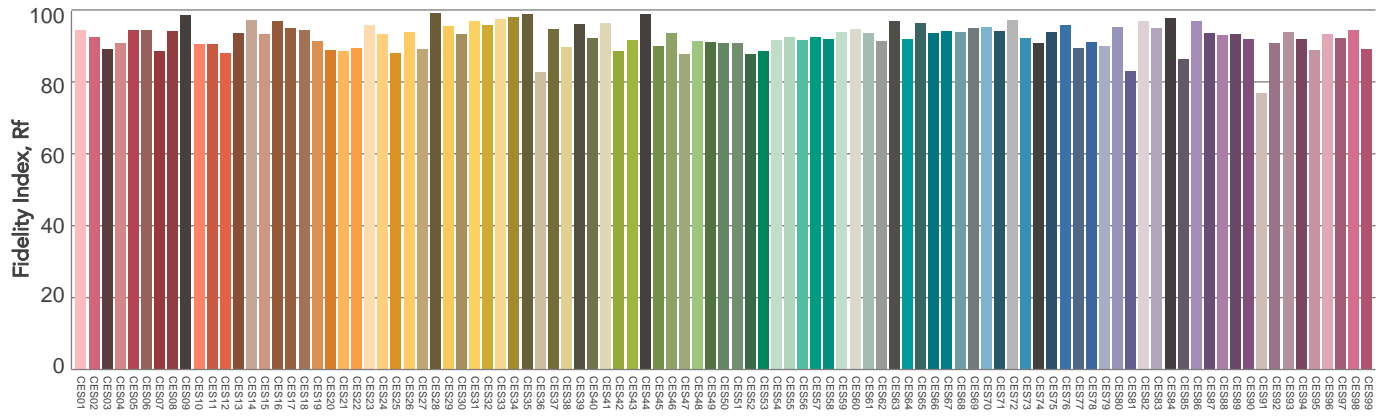
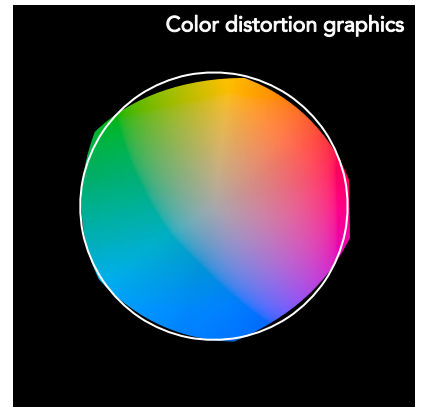
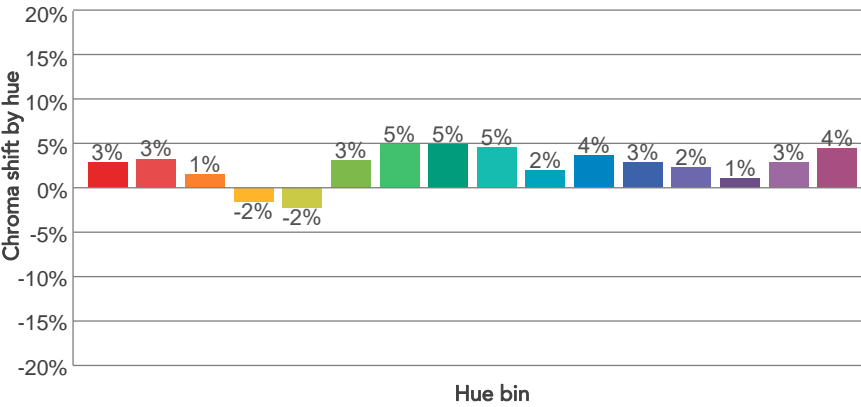
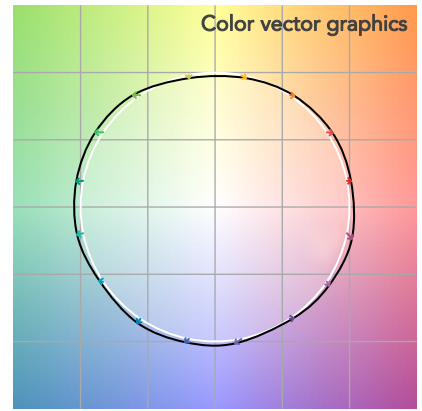
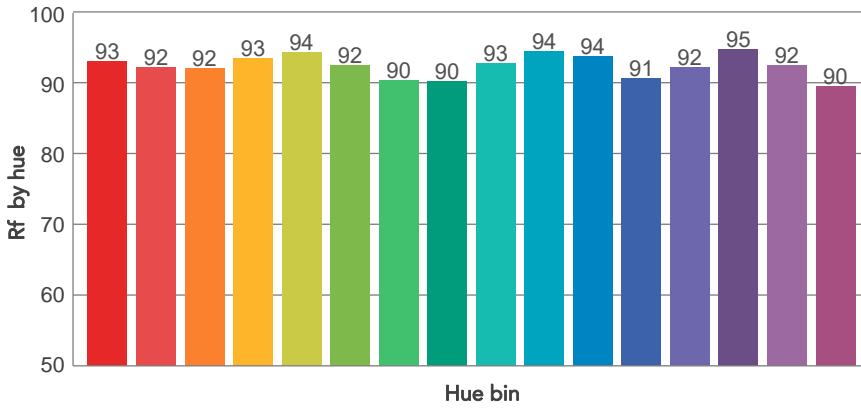
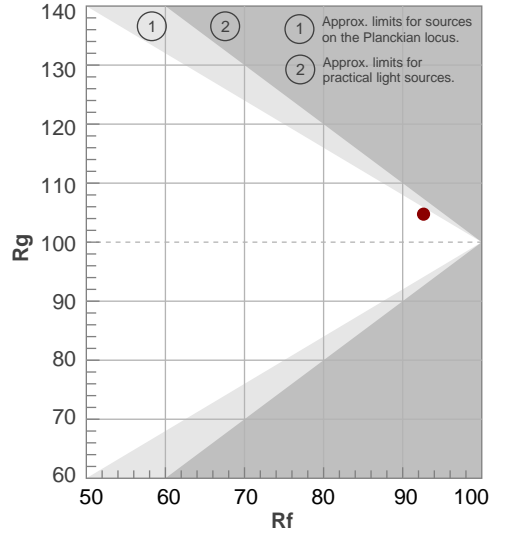

# BEAM DETAILS



Beam angle 50%	Field angle 10%	Cut off angle 2,5%	Intensity ratio in 120° cone	Intensity ratio in 90° cone
60,3°	81°	88,6°	100,0%	99,6%

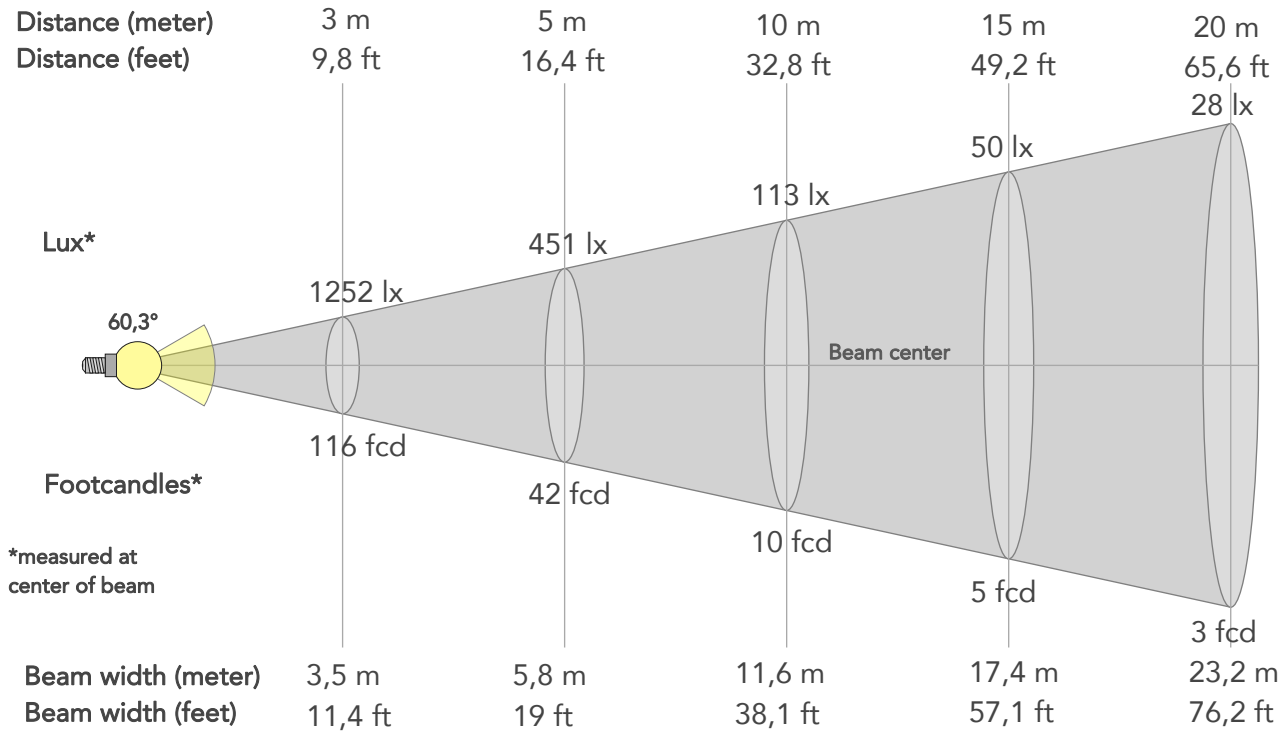

## BEAM INTENSITIES AND WIDTHS

Distance	1m	2m	3m	4m	5m	7,5m	10m	15m	20m	25m	30m	40m	50m
Distance	3,3ft	6,6ft	9,8ft	13,1ft	16,4ft	24,6ft	32,8ft	49,2ft	65,6ft	82ft	98,4ft	131,2ft	164ft
Lux	11271lx	2818lx	1252lx	704lx	451lx	200lx	113lx	50lx	28lx	18lx	13lx	7lx	5lx
Footcand.	1047fcd	262fcd	116fcd	65fcd	42fcd	19fcd	10fcd	5fcd	3fcd	2fcd	1fcd	1fcd	0fcd
Beam wid.	1,2m	2,3m	3,5m	4,6m	5,8m	8,7m	11,6m	17,4m	23,2m	29m	34,8m	46,4m	58,1m
Beam wid.	3,8ft	7,7ft	11,4ft	15,2ft	19ft	28,6ft	38,1ft	57,1ft	76,2ft	95,2ft	114,2ft	152,3ft	190,4ft

## LINEAR DISTRIBUTION DIAGRAM

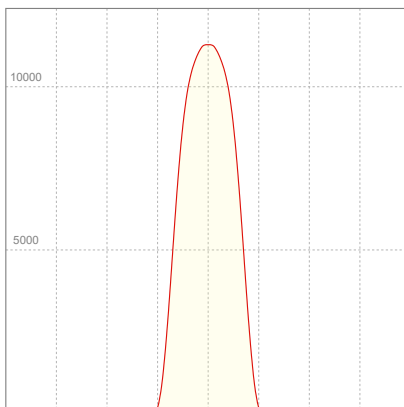

## ELECTRICAL SPECIFICATIONS

Input voltage	Input current	Input power	Effeciency
228V	1,44A	321W	31lm/W

## ISO CANDELA DIAGRAM

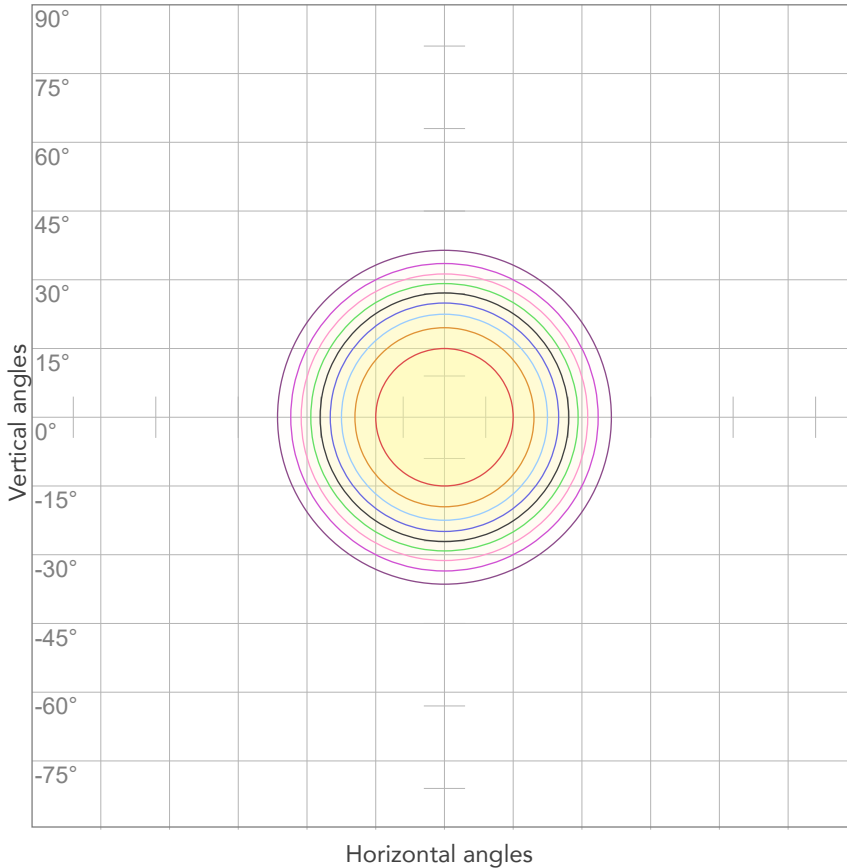

10%	1127 cd
20%	2254 cd
30%	3381 cd
40%	4508 cd
50%	5636 cd
60%	6763 cd
70%	7890 cd
80%	9017 cd

Conditions:

Number of c-planes: 2

Candela at center: 11271 cd

## ISO LUX DIAGRAM

MH: 10,0 m

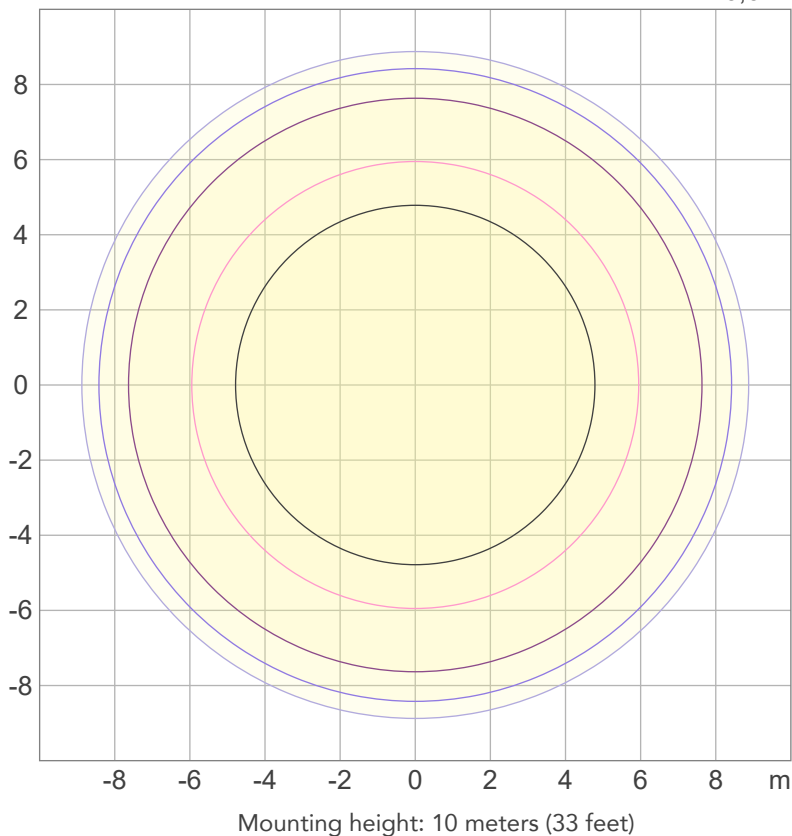

3%	3,38 lx
5%	5,64 lx
10%	11,3 lx
30%	33,8 lx
50%	56,4 lx

Conditions:

Number of c-planes: 2

Lux at center: 113 lx

*Lux distribution on a surface when lamp is mounted at 10 meters from the surface.*



Total lumen output:

7354 lm

Peak candela output:

38954 cd

Light quality:

CRI: 91,5

Color temperature:

3988 K

PRODUCT NAME:

ECLFRCTPM

MEASURAMENT CONDITIONS:

Beam angle:

Med Zoom

Target:

4000K - HB

Operator:

Salvatore Giglio

Date and time:

03/10/2023 11:55:57

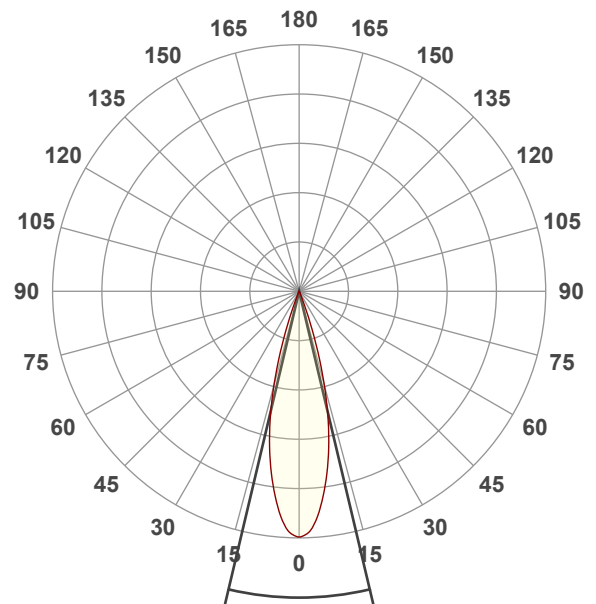

Beam angle 50%: 26,7°

Field angle 10%: 40,2°

Cut off angle 2.5%: 44,9°

Spectra

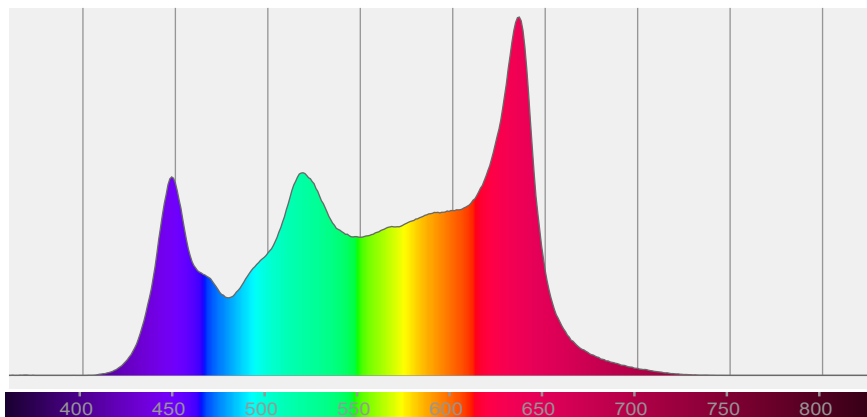

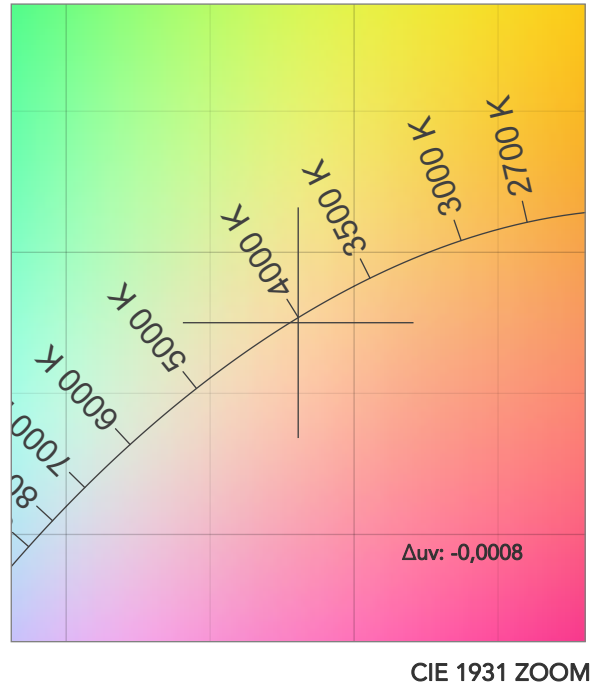
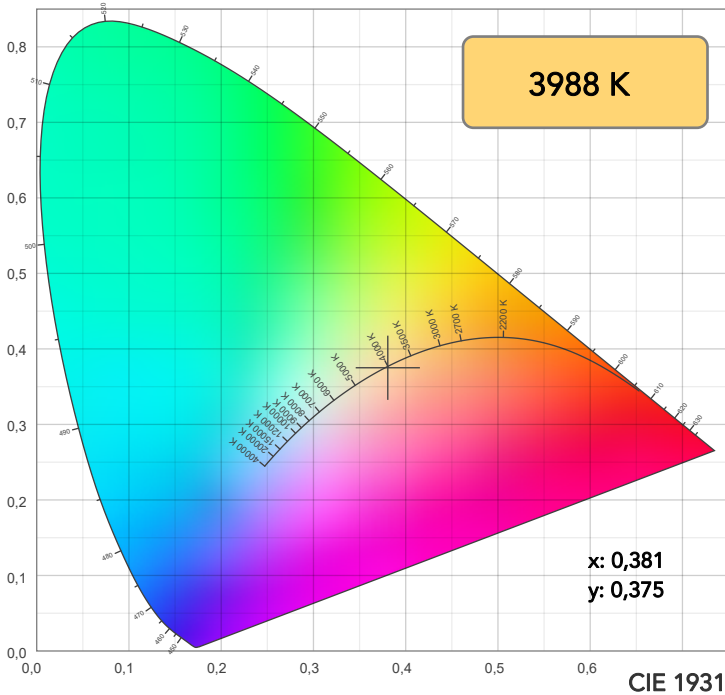

TM30: 92,7

CRI: 91,5 (R1-R8)

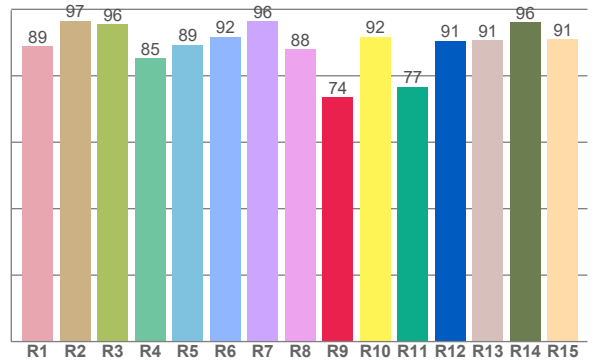
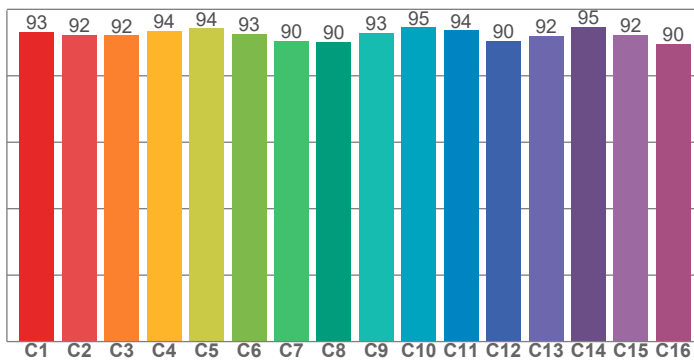

CRI R values, only R1-R8 are used to calculate final CRI value

R1	R2	R3	R4	R5	R6	R7	R8	R9	R10	R11	R12	R13	R14	R15
89,0	96,6	95,5	85,2	89,4	91,7	96,4	88,1	73,6	91,7	76,7	90,6	90,7	96,1	90,9

TM30 C values, 16 binned values out of total of 99 C values

C1	C2	C3	C4	C5	C6	C7	C8	C9	C10	C11	C12	C13	C14	C15	C16
93,2	92,3	92,2	93,5	94,3	92,6	90,5	90,3	92,9	94,6	93,7	90,5	92,0	94,8	92,4	89,6

CQS Q values

Q1	Q2	Q3	Q4	Q5	Q6	Q7	Q8	Q9	Q10	Q11	Q12	Q13	Q14	Q15
96,9	97,5	98,3	93,8	91,4	92,6	98,4	94,8	97,6	96,9	91,4	91,4	93,1	96,2	95,7

CQS: 94,5

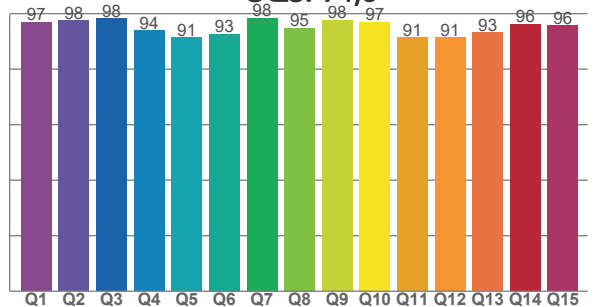

COLOR PARAMETERS

Color temperature	Color rendering index	Red component	Color fidelity	Color gamut	Color quality scale	Television lighting index	Color coordinate cie 1931	Color coordinate cie 1931	Color deviation from black body
CCT	CRI	CRI R9	TM30 Rf	TM30 Rg	CQS	TLCI	x	y	Δuv
3988 K	91,5	73,6	92,7	104,6	94,5	87	0,381	0,375	-0,0008



# TM30 DETAILS

**Rf 92,7**  
Fidelity index Rf

**Rg 104,6**  
Gammut index

Hue Bin	R <sub>f</sub>	Graphic shifts (%)	
		Chroma	Hue
1	93	3%	-1%
2	92	3%	-3%
3	92	1%	-3%
4	94	-2%	-4%
5	94	-2%	0%
6	93	3%	4%
7	90	5%	3%
8	90	5%	2%
9	93	5%	0%
10	95	2%	-2%
11	94	4%	0%
12	90	3%	-2%
13	92	2%	-5%
14	95	1%	3%
15	92	3%	-2%
16	90	4%	-3%

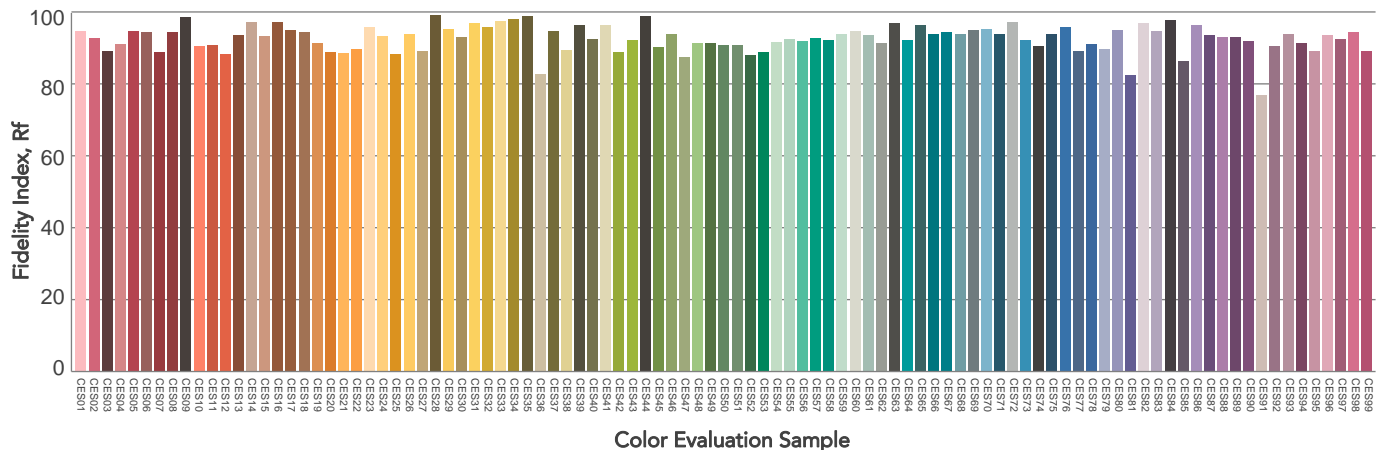
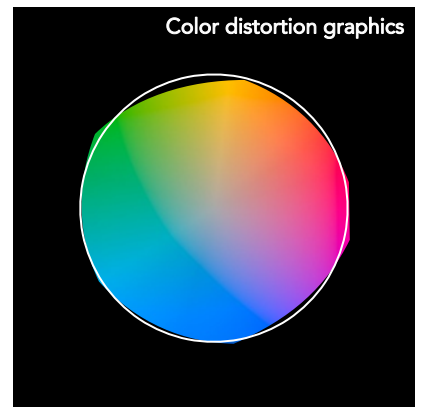
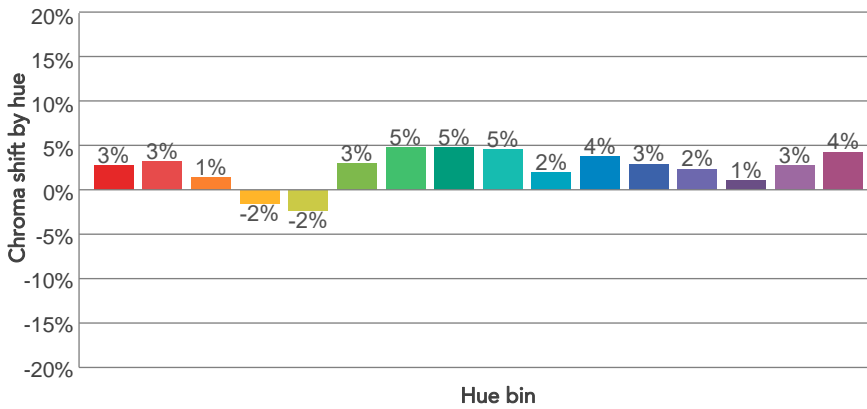
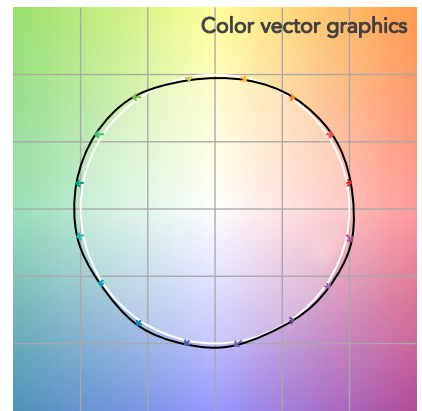
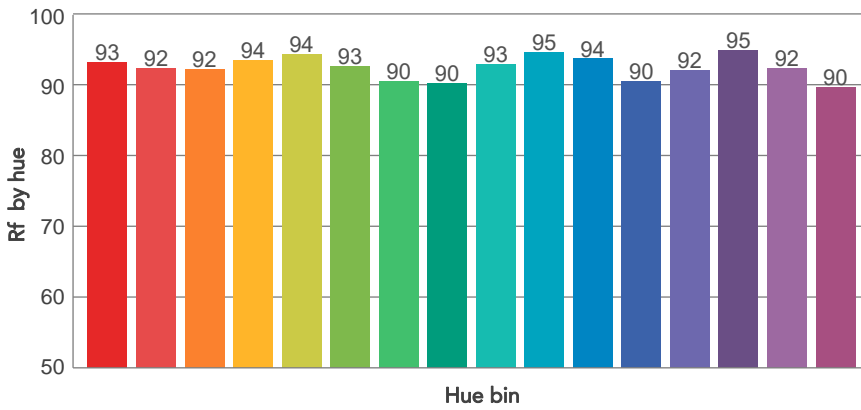
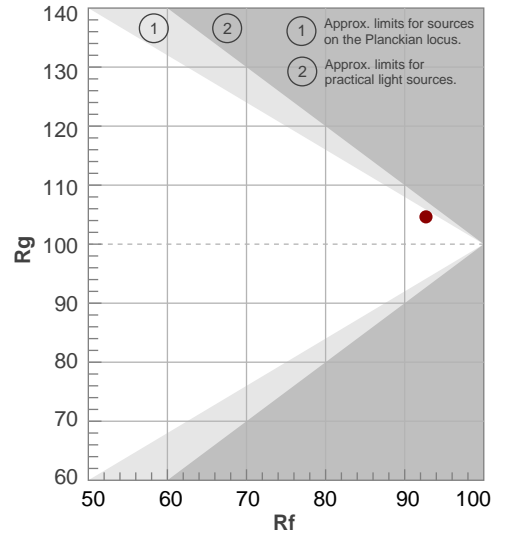

# BEAM DETAILS



Beam angle 50%	Field angle 10%	Cut off angle 2,5%	Intensity ratio in 120° cone	Intensity ratio in 90° cone
26,7°	40,2°	44,9°	100,0%	100,0%

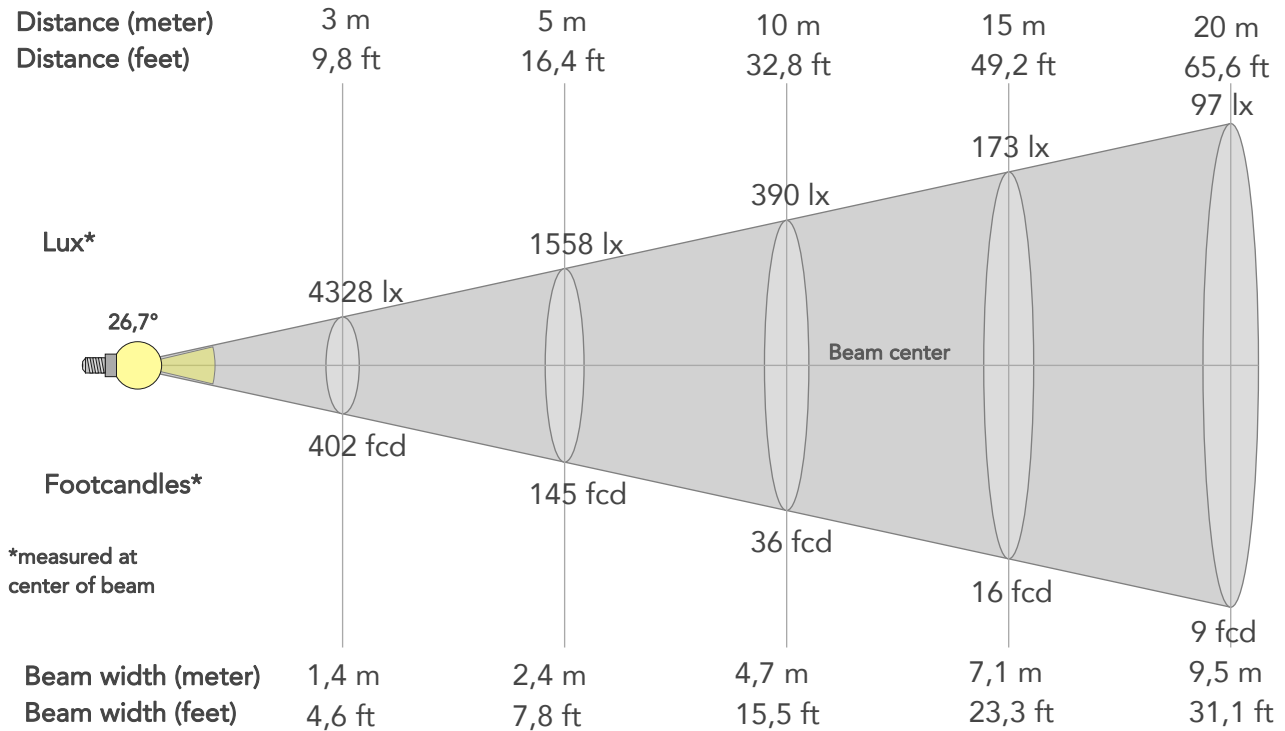

## BEAM INTENSITIES AND WIDTHS

Distance	1m	2m	3m	4m	5m	7,5m	10m	15m	20m	25m	30m	40m	50m
Distance	3,3ft	6,6ft	9,8ft	13,1ft	16,4ft	24,6ft	32,8ft	49,2ft	65,6ft	82ft	98,4ft	131,2ft	164ft
Lux	38954lx	9739lx	4328lx	2435lx	1558lx	693lx	390lx	173lx	97lx	62lx	43lx	24lx	16lx
Footcand.	3619fcd	905fcd	402fcd	226fcd	145fcd	64fcd	36fcd	16fcd	9fcd	6fcd	4fcd	2fcd	1fcd
Beam wid.	0,5m	0,9m	1,4m	1,9m	2,4m	3,6m	4,7m	7,1m	9,5m	11,8m	14,2m	19m	23,7m
Beam wid.	1,6ft	3,1ft	4,6ft	6,2ft	7,8ft	11,7ft	15,5ft	23,3ft	31,1ft	38,9ft	46,6ft	62,2ft	77,7ft

## LINEAR DISTRIBUTION DIAGRAM

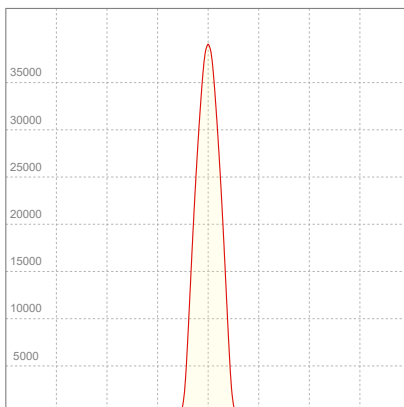

## ELECTRICAL SPECIFICATIONS

Input voltage	Input current	Input power	Effeciency
224V	1,44A	317,6W	23lm/W

## ISO CANDELA DIAGRAM

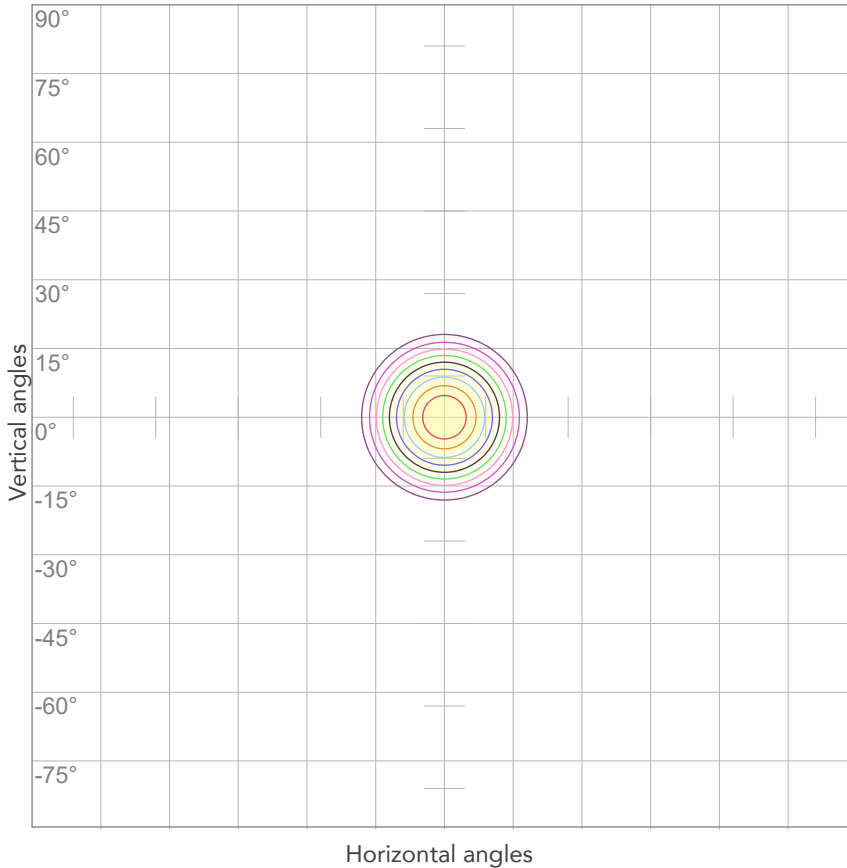

10%	3895 cd
20%	7791 cd
30%	11686 cd
40%	15582 cd
50%	19477 cd
60%	23373 cd
70%	27268 cd
80%	31164 cd

Conditions:

Number of c-planes: 2

Candela at center: 38954 cd

## ISO LUX DIAGRAM

MH: 10,0 m

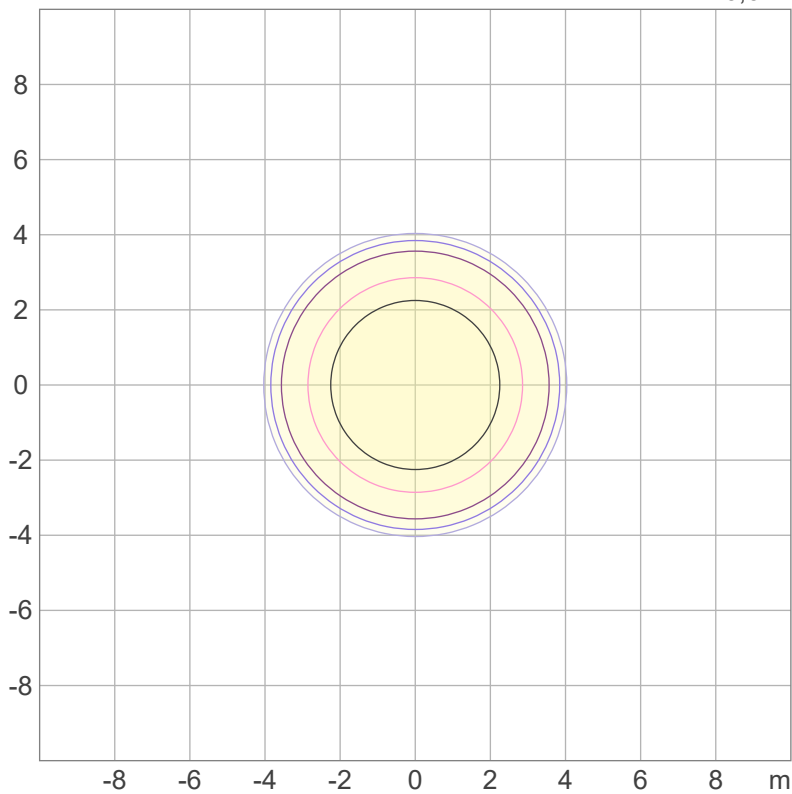

Mounting height: 10 meters (33 feet)

3%	11,7 lx
5%	19,5 lx
10%	39,0 lx
30%	117 lx
50%	195 lx

Conditions:

Number of c-planes: 2

Lux at center: 390 lx

*Lux distribution on a surface when lamp is mounted at 10 meters from the surface.*



Total lumen output:

3867 lm

Peak candela output:

142645 cd

Light quality:

CRI: 92,3

Color temperature:

3976 K

PRODUCT NAME:

ECLFRCTPM

MEASURAMENT CONDITIONS:

Beam angle:

Min Zoom

Target:

4000K - HB

Operator:

Salvatore Giglio

Date and time:

03/10/2023 11:36:43

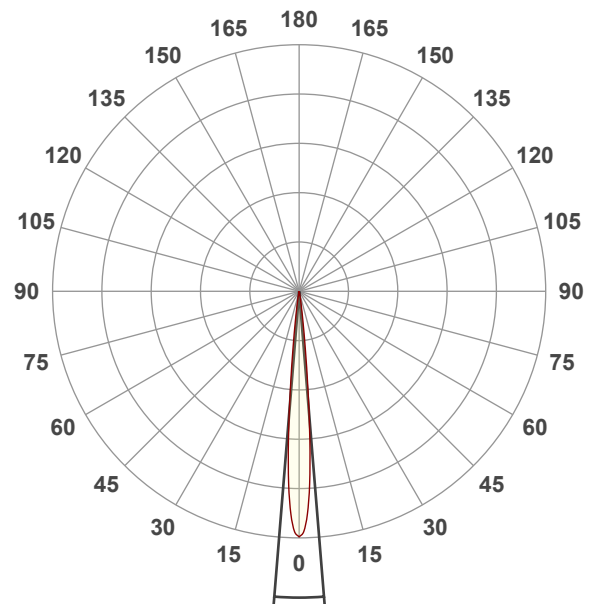

Spectra

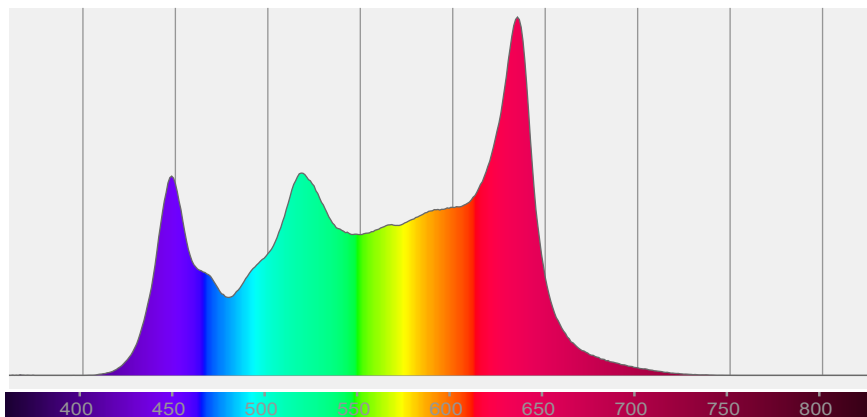

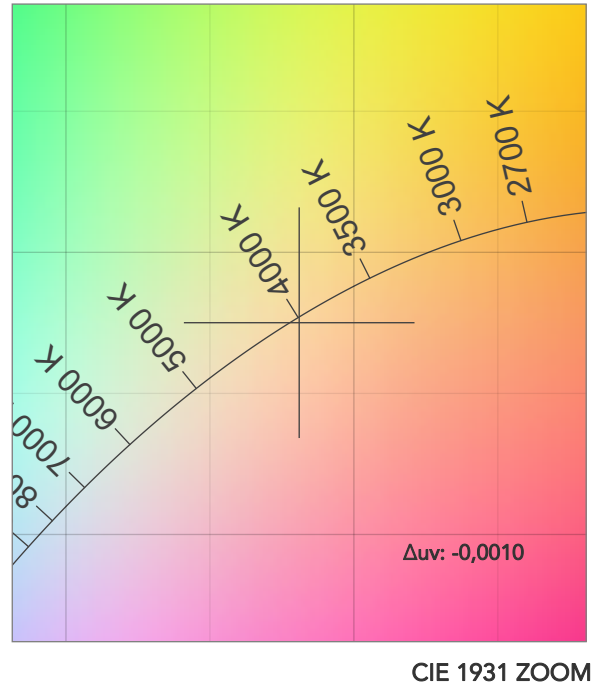
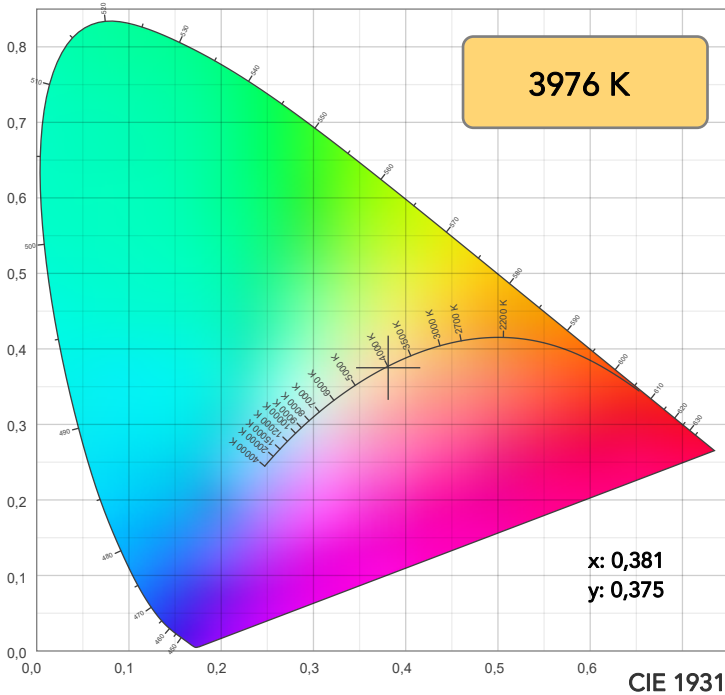

TM30: 93,0

CRI: 92,3 (R1-R8)

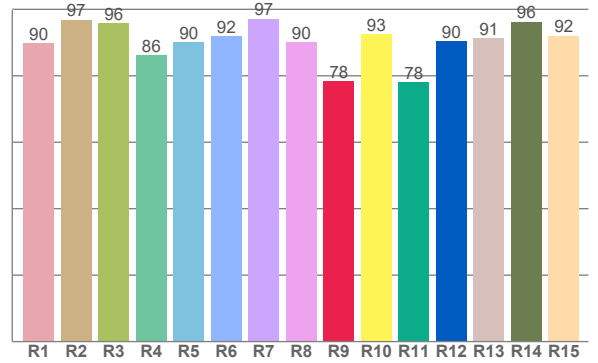
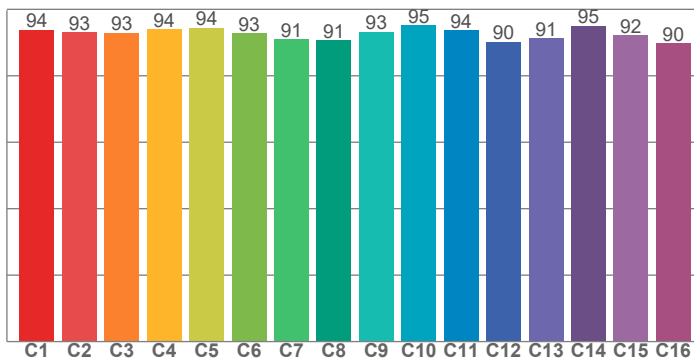

CRI R values, only R1-R8 are used to calculate final CRI value

R1	R2	R3	R4	R5	R6	R7	R8	R9	R10	R11	R12	R13	R14	R15
89,8	96,9	95,8	86,2	90,2	92,0	97,2	90,1	78,3	92,5	78,0	90,5	91,4	96,2	92,1

TM30 C values, 16 binned values out of total of 99 C values

C1	C2	C3	C4	C5	C6	C7	C8	C9	C10	C11	C12	C13	C14	C15	C16
93,8	93,0	92,9	94,0	94,4	92,7	90,9	90,7	93,2	95,2	93,6	90,3	91,3	95,0	92,1	89,7

CQS Q values

Q1	Q2	Q3	Q4	Q5	Q6	Q7	Q8	Q9	Q10	Q11	Q12	Q13	Q14	Q15
97,3	97,4	97,9	94,7	92,1	92,9	98,6	95,4	97,9	97,5	92,2	92,2	93,8	96,4	96,2

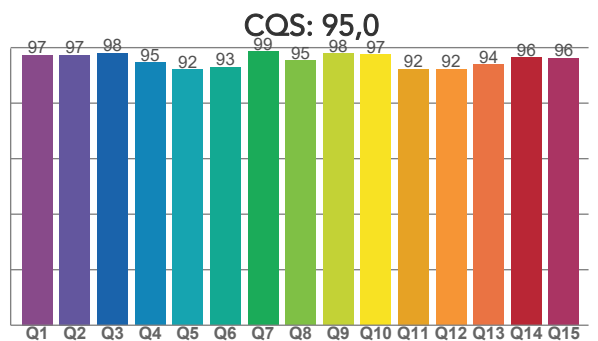

COLOR PARAMETERS

Color temperature	Color rendering index	Red component	Color fidelity	Color gamut	Color quality scale	Television lighting index	Color coordinate cie 1931	Color coordinate cie 1931	Color deviation from black body
CCT	CRI	CRI R9	TM30 Rf	TM30 Rg	CQS	TLCI	x	y	$\Delta uv$
3976 K	92,3	78,3	93,0	104,3	95,0	88	0,381	0,375	-0,0010

# TM30 DETAILS

**Rf 93,0**  
Fidelity index Rf

**Rg 104,3**  
Gammut index

Hue Bin	R <sub>f</sub>	Graphic shifts (%)	
		Chroma	Hue
1	94	2%	-1%
2	93	3%	-2%
3	93	1%	-2%
4	94	-1%	-3%
5	94	-2%	0%
6	93	3%	4%
7	91	5%	3%
8	91	5%	2%
9	93	4%	1%
10	95	2%	-2%
11	94	4%	0%
12	90	3%	-2%
13	91	3%	-6%
14	95	1%	2%
15	92	2%	-2%
16	90	4%	-4%

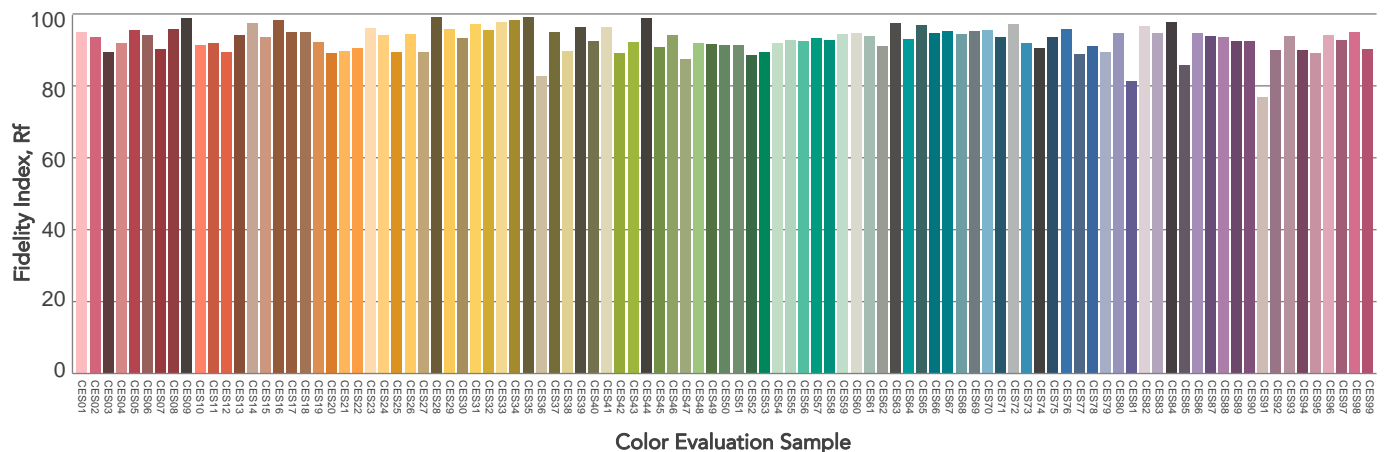
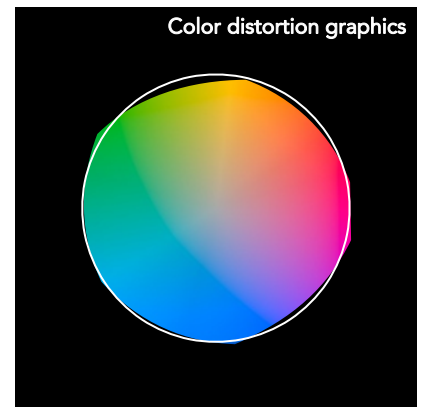
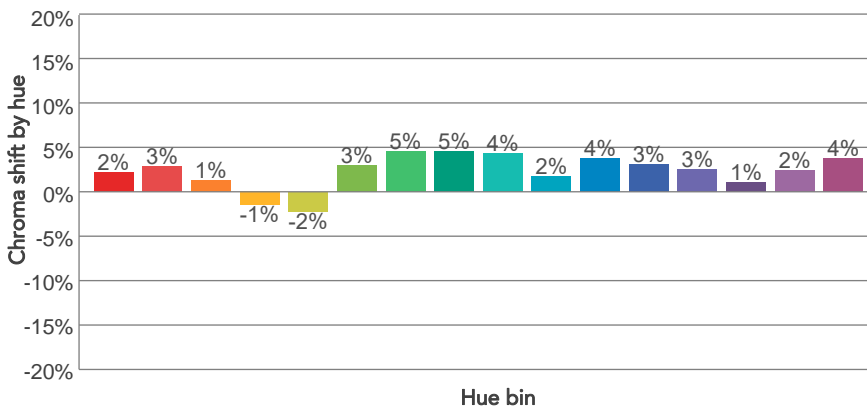
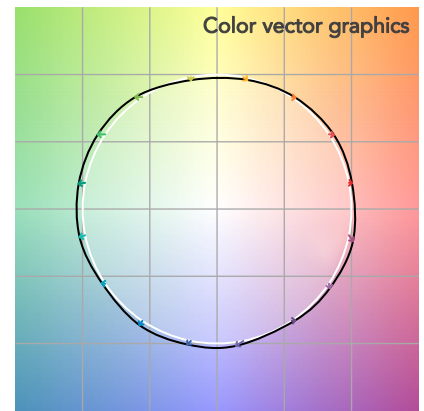
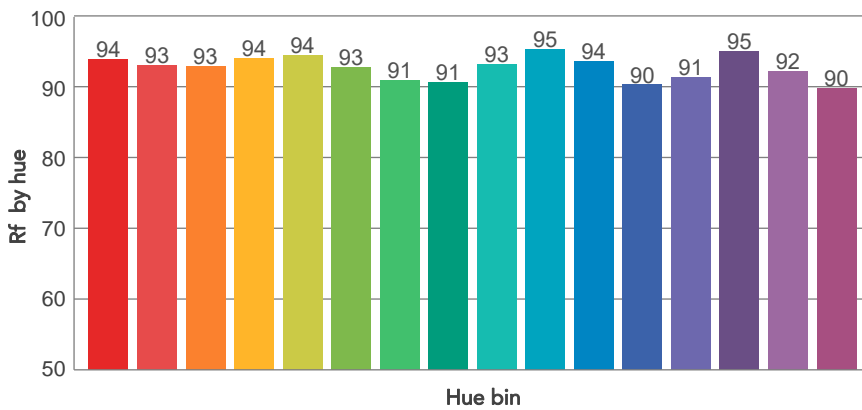
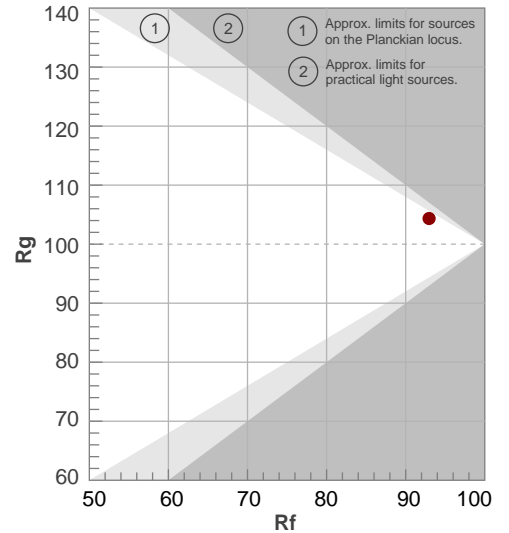

# BEAM DETAILS



Beam angle 50%	Field angle 10%	Cut off angle 2,5%	Intensity ratio in 120° cone	Intensity ratio in 90° cone
9,3°	15,3°	19,9°	100,0%	100,0%

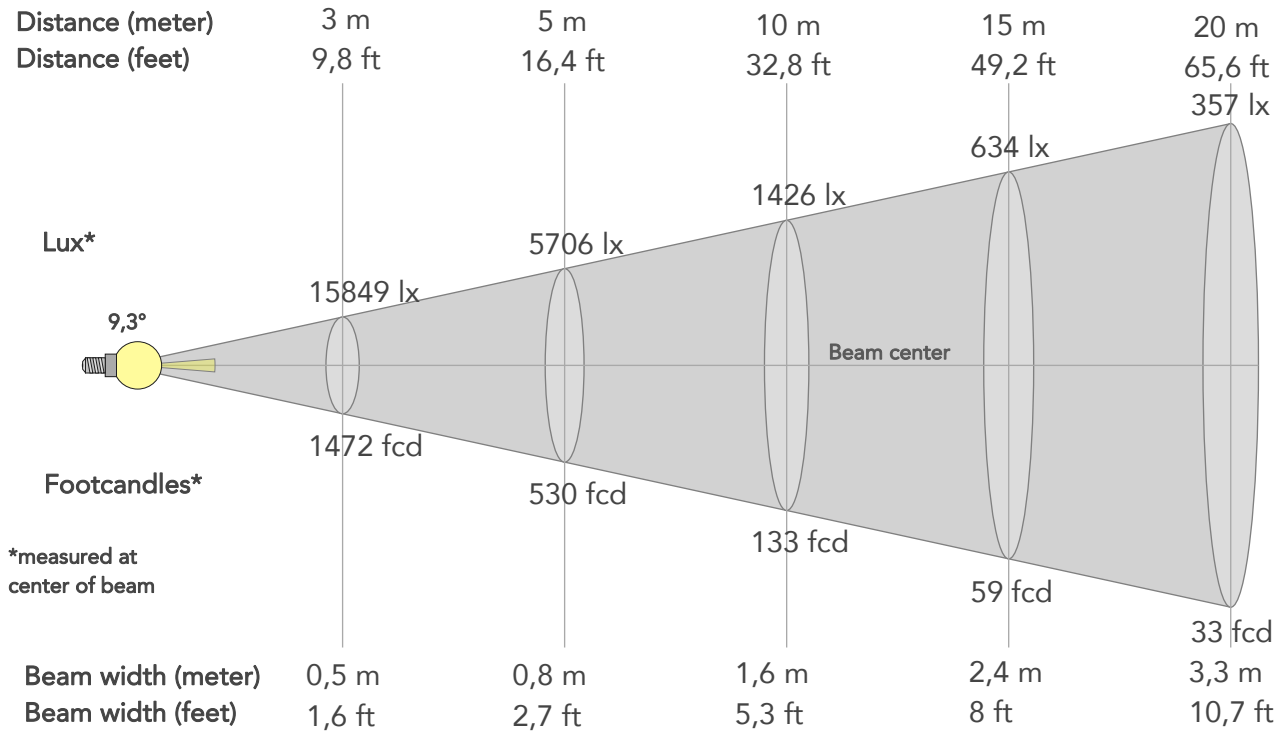

## BEAM INTENSITIES AND WIDTHS

Distance	1m	2m	3m	4m	5m	7,5m	10m	15m	20m	25m	30m	40m	50m
Distance	3,3ft	6,6ft	9,8ft	13,1ft	16,4ft	24,6ft	32,8ft	49,2ft	65,6ft	82ft	98,4ft	131,2ft	164ft
Lux	142645lx	35661lx	15849lx	8915lx	5706lx	2536lx	1426lx	634lx	357lx	228lx	158lx	89lx	57lx
Footcand.	13252fcd	3313fcd	1472fcd	828fcd	530fcd	236fcd	133fcd	59fcd	33fcd	21fcd	15fcd	8fcd	5fcd
Beam wid.	0,2m	0,3m	0,5m	0,7m	0,8m	1,2m	1,6m	2,4m	3,3m	4,1m	4,9m	6,5m	8,1m
Beam wid.	0,5ft	1,1ft	1,6ft	2,1ft	2,7ft	4ft	5,3ft	8ft	10,7ft	13,3ft	16ft	21,3ft	26,7ft

## LINEAR DISTRIBUTION DIAGRAM

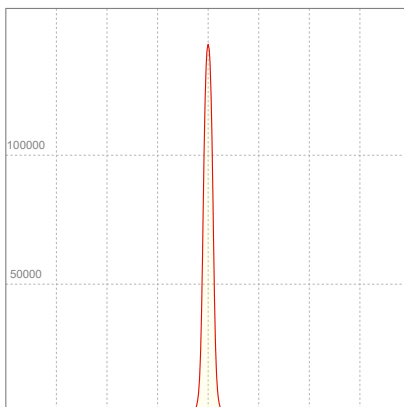

## ELECTRICAL SPECIFICATIONS

Input voltage	Input current	Input power	Effeciency
227V	1,41A	313,1W	12lm/W

## ISO CANDELA DIAGRAM

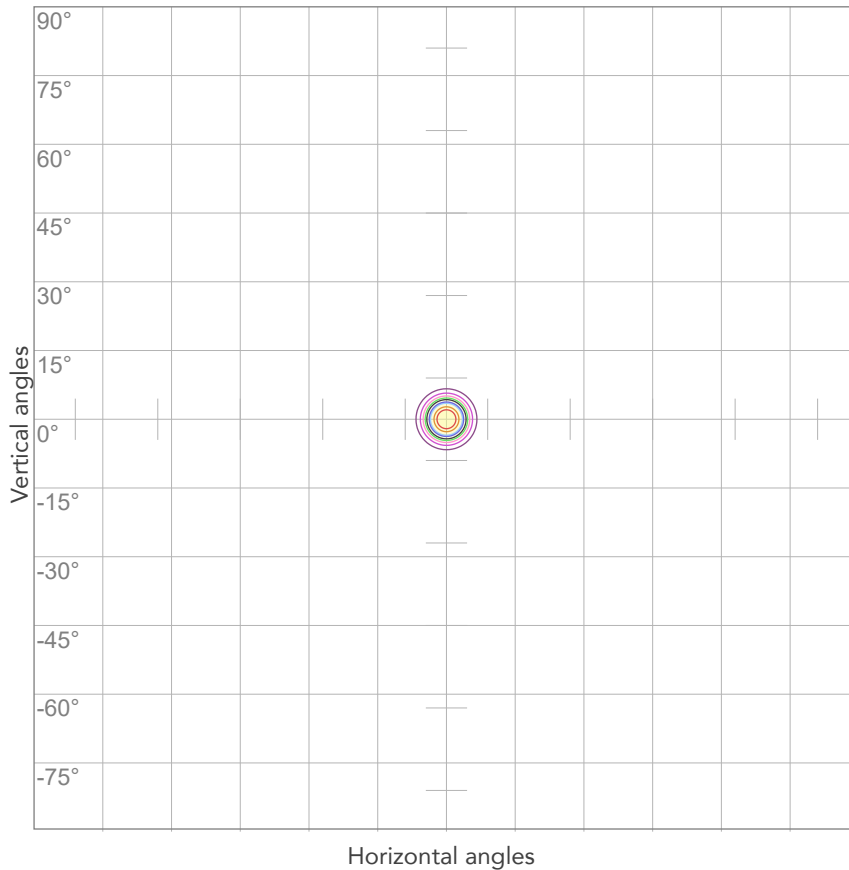

10%	14264 cd
20%	28529 cd
30%	42793 cd
40%	57058 cd
50%	71322 cd
60%	85587 cd
70%	99851 cd
80%	114116 cd

Conditions:

Number of c-planes: 2

Candela at center: 142645 cd

## ISO LUX DIAGRAM

MH: 10,0 m

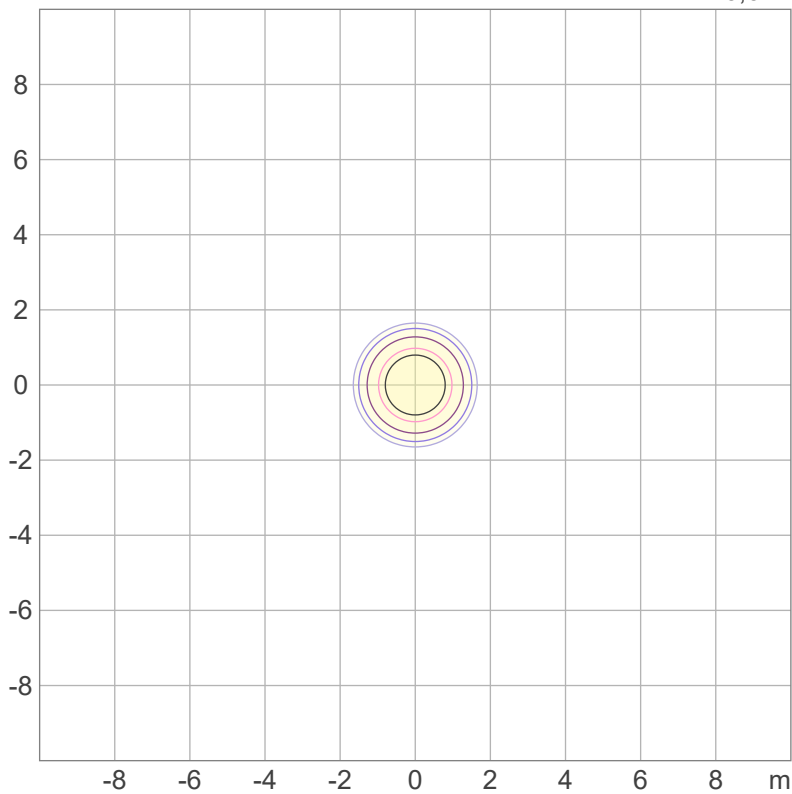

3%	42,8 lx
5%	71,3 lx
10%	143 lx
30%	428 lx
50%	713 lx

Conditions:

Number of c-planes: 2

Lux at center: 1426 lx

*Lux distribution on a surface when lamp is mounted at 10 meters from the surface.*





Total lumen output:

9500 lm

Peak candela output:

10847 cd

Light quality:

CRI: 95,7

Color temperature:

5575 K

PRODUCT NAME:

ECLFRCTPM

MEASURAMENT CONDITIONS:

Beam angle:

Max Zoom

Target:

5600K - HB

Operator:

Salvatore Giglio

Date and time:

03/10/2023 10:33:55

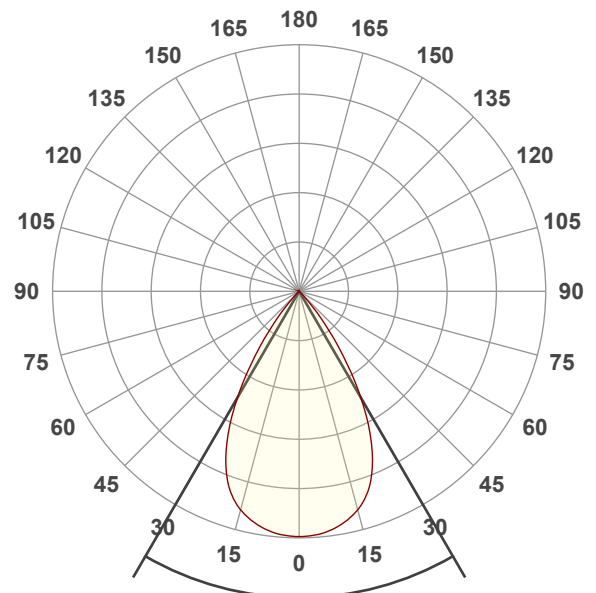

Spectra

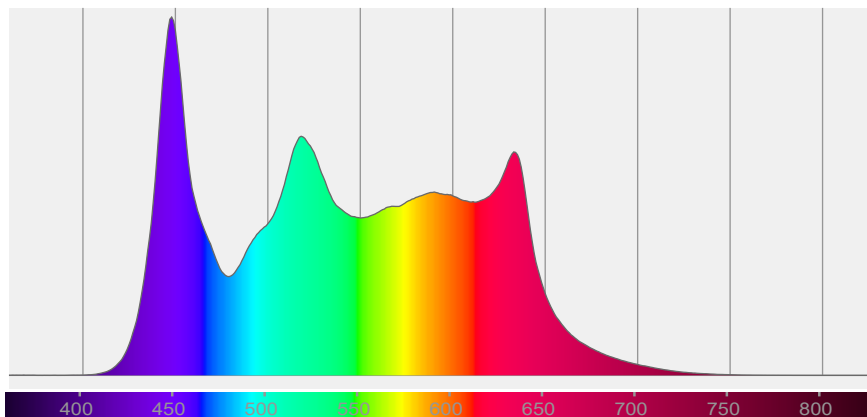

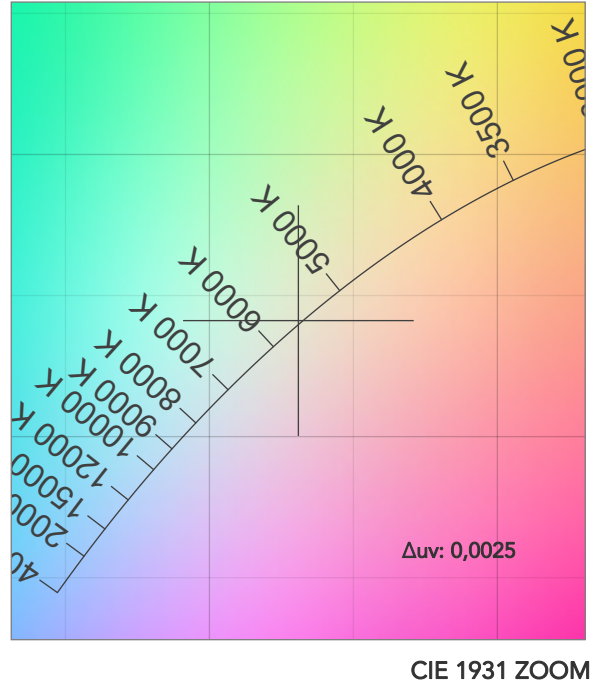
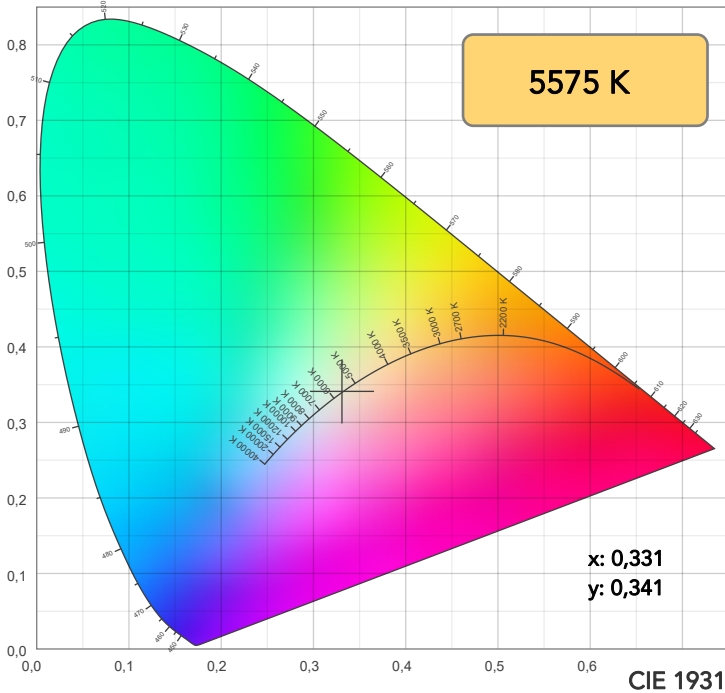

TM30: 93,1

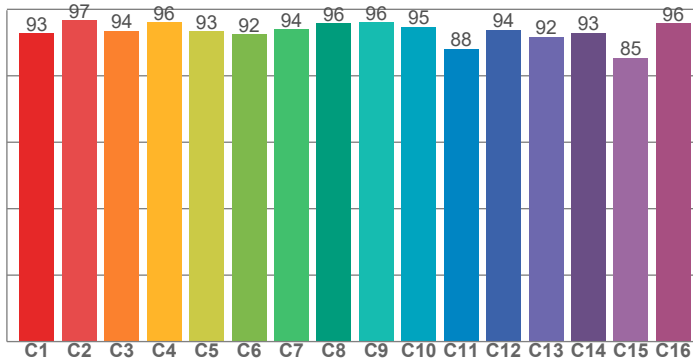

CRI: 95,7 (R1-R8)

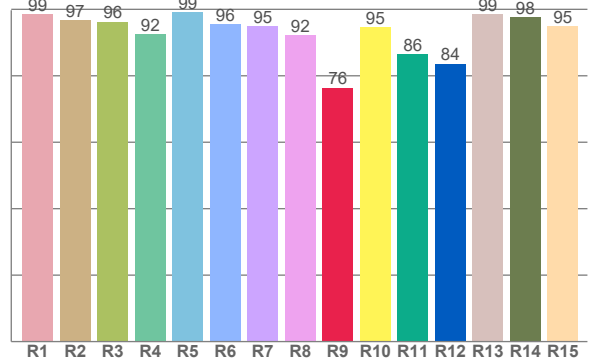

CQS: 94,7

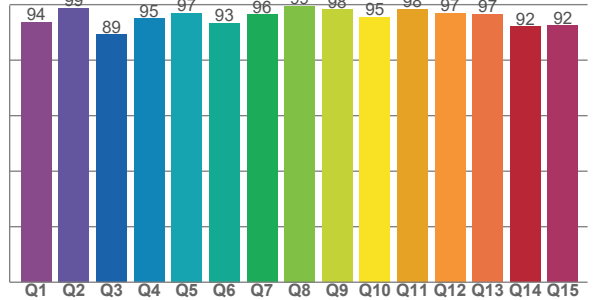

CRI R values, only R1-R8 are used to calculate final CRI value

R1	R2	R3	R4	R5	R6	R7	R8	R9	R10	R11	R12	R13	R14	R15
98,5	96,8	96,3	92,4	99,1	95,6	94,9	92,2	76,4	94,5	86,5	83,6	98,6	97,5	95,0

TM30 C values, 16 binned values out of total of 99 C values

C1	C2	C3	C4	C5	C6	C7	C8	C9	C10	C11	C12	C13	C14	C15	C16
92,7	96,7	93,5	96,1	93,3	92,5	93,9	95,7	96,0	94,7	88,0	93,9	91,7	93,0	85,4	95,8

CQS Q values

Q1	Q2	Q3	Q4	Q5	Q6	Q7	Q8	Q9	Q10	Q11	Q12	Q13	Q14	Q15
93,6	98,8	89,3	94,9	97,0	93,3	96,4	99,5	98,3	95,5	98,5	97,0	96,5	92,1	92,4

COLOR PARAMETERS

Color temperature	Color rendering index	Red component	Color fidelity	Color gamut	Color quality scale	Television lighting index	Color coordinate cie 1931	Color coordinate cie 1931	Color deviation from black body
CCT	CRI	CRI R9	TM30 Rf	TM30 Rg	CQS	TLCI	x	y	Δuv
5575 K	95,7	76,4	93,1	102,8	94,7	91	0,331	0,341	0,0025

# TM30 DETAILS

**Rf 93,1**  
Fidelity index Rf

**Rg 102,8**  
Gammut index

Hue Bin	R <sub>f</sub>	Graphic shifts (%)	
		Chroma	Hue
1	93	-3%	-1%
2	97	-1%	2%
3	94	0%	3%
4	96	0%	2%
5	93	0%	2%
6	92	5%	3%
7	94	4%	1%
8	96	1%	0%
9	96	0%	1%
10	95	-1%	3%
11	88	2%	7%
12	94	3%	0%
13	92	5%	-4%
14	93	3%	-2%
15	85	6%	-12%
16	96	0%	-2%

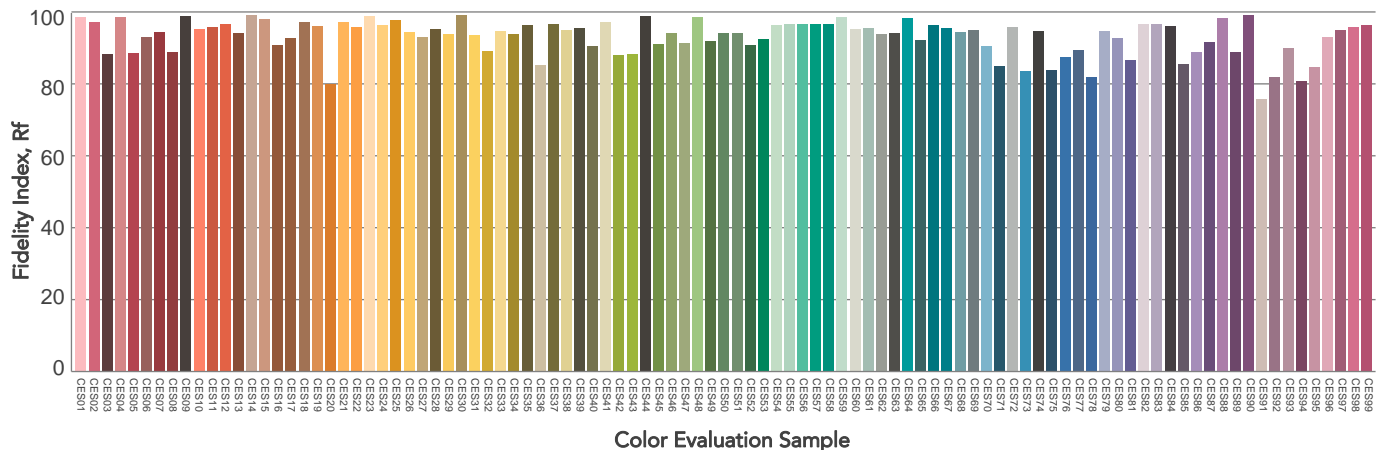
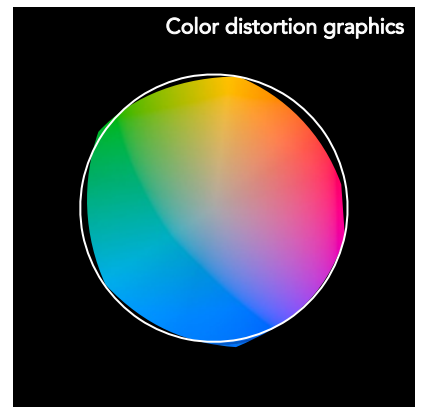
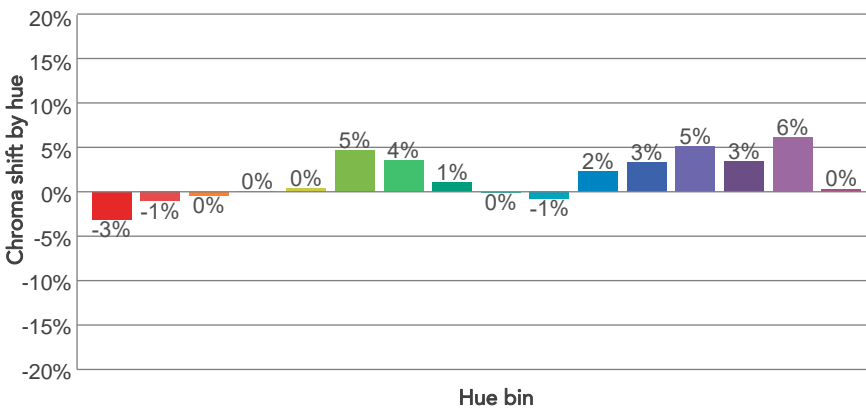
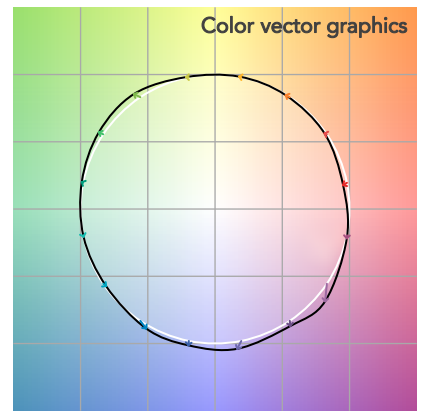
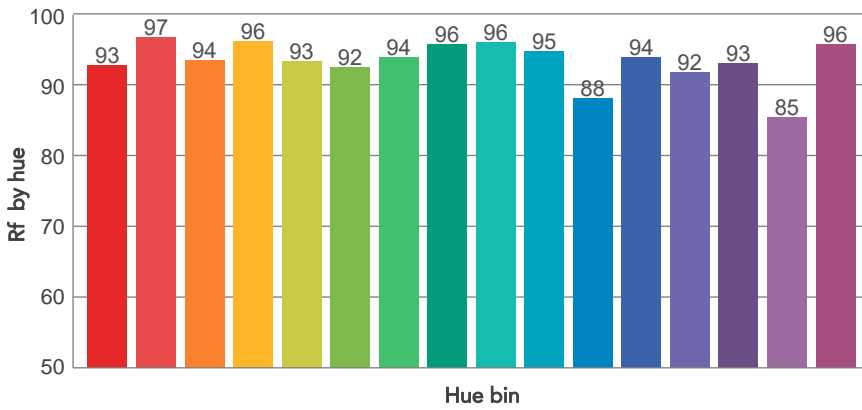
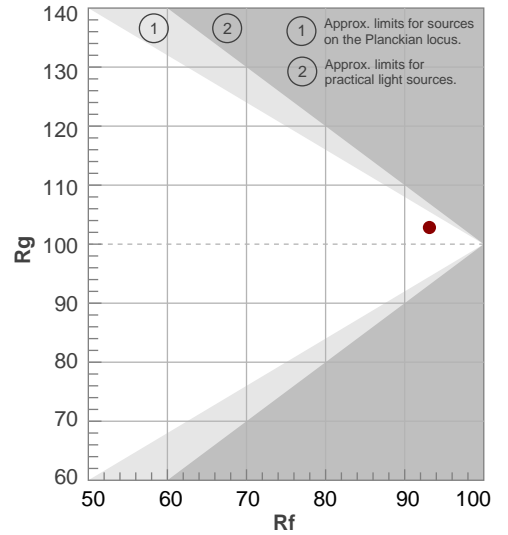

# BEAM DETAILS



Beam angle 50%	Field angle 10%	Cut off angle 2,5%	Intensity ratio in 120° cone	Intensity ratio in 90° cone
60,2°	81,4°	89,7°	99,9%	99,5%

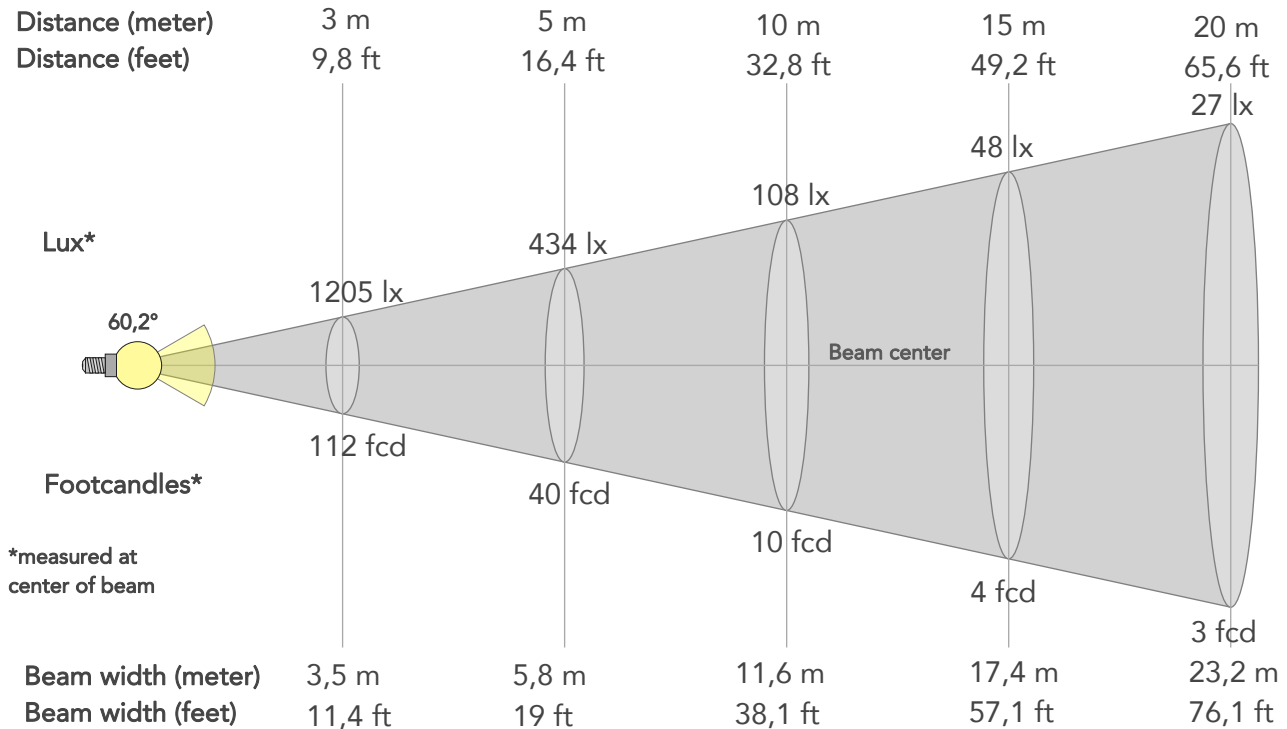

## BEAM INTENSITIES AND WIDTHS

Distance	1m	2m	3m	4m	5m	7,5m	10m	15m	20m	25m	30m	40m	50m
Distance	3,3ft	6,6ft	9,8ft	13,1ft	16,4ft	24,6ft	32,8ft	49,2ft	65,6ft	82ft	98,4ft	131,2ft	164ft
Lux	10847lx	2712lx	1205lx	678lx	434lx	193lx	108lx	48lx	27lx	17lx	12lx	7lx	4lx
Footcand.	1008fcd	252fcd	112fcd	63fcd	40fcd	18fcd	10fcd	4fcd	3fcd	2fcd	1fcd	1fcd	0fcd
Beam wid.	1,2m	2,3m	3,5m	4,6m	5,8m	8,7m	11,6m	17,4m	23,2m	29m	34,8m	46,4m	58m
Beam wid.	3,8ft	7,7ft	11,4ft	15,2ft	19ft	28,5ft	38,1ft	57,1ft	76,1ft	95,2ft	114,2ft	152,3ft	190,3ft

## LINEAR DISTRIBUTION DIAGRAM

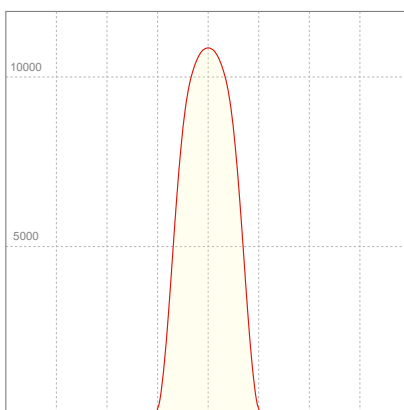

## ELECTRICAL SPECIFICATIONS

Input voltage	Input current	Input power	Effeciency
228V	1,37A	306W	31lm/W

## ISO CANDELA DIAGRAM

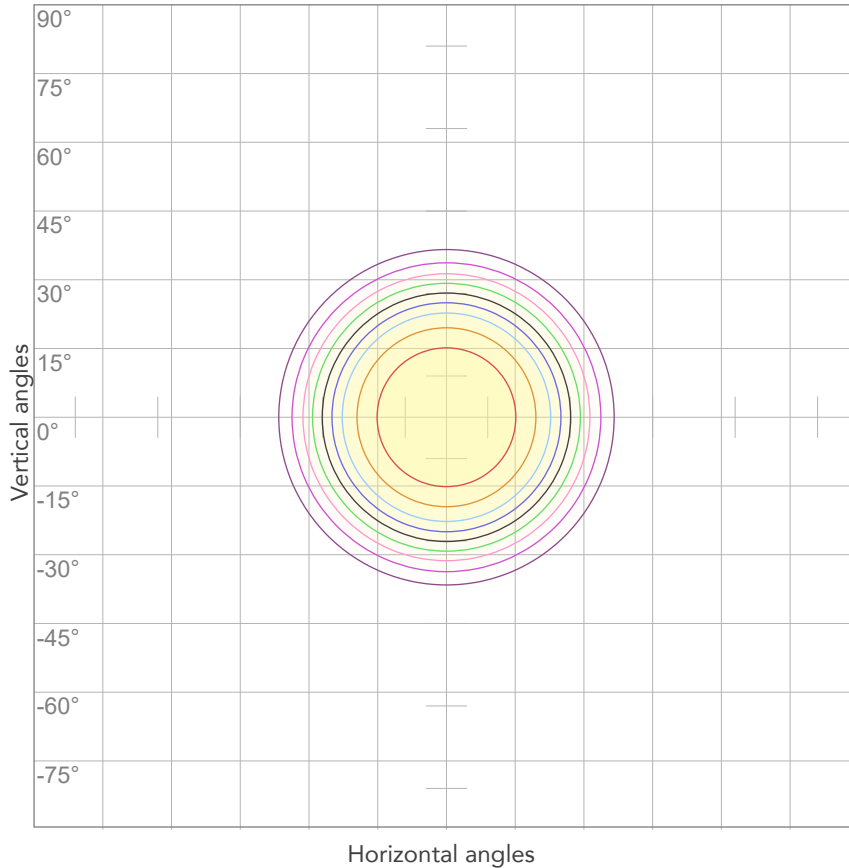

10%	1085 cd
20%	2169 cd
30%	3254 cd
40%	4339 cd
50%	5424 cd
60%	6508 cd
70%	7593 cd
80%	8678 cd

Conditions:

Number of c-planes: 2

Candela at center: 10847 cd

## ISO LUX DIAGRAM

MH: 10,0 m

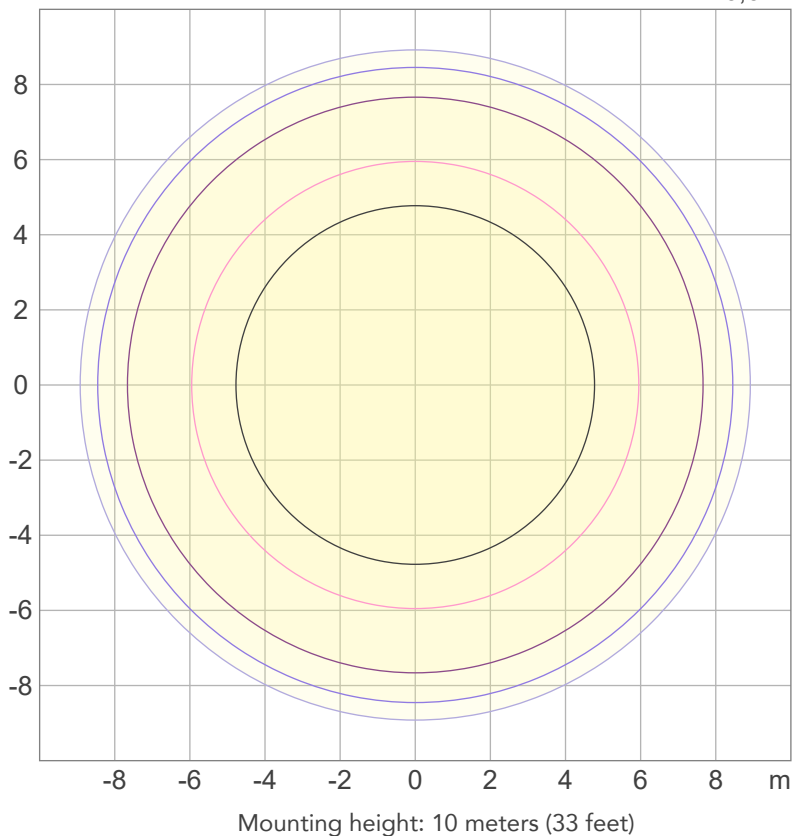

3%	3,25 lx
5%	5,42 lx
10%	10,8 lx
30%	32,5 lx
50%	54,2 lx

Conditions:

Number of c-planes: 2

Lux at center: 108 lx

*Lux distribution on a surface when lamp is mounted at 10 meters from the surface.*



Total lumen output:

7246 lm

Peak candela output:

37419 cd

Light quality:

CRI: 95,7

Color temperature:

5583 K

PRODUCT NAME:

ECLFRCTPM

MEASURAMENT CONDITIONS:

Beam angle:

Med Zoom

Target:

5600K - HB

Operator:

Salvatore Giglio

Date and time:

03/10/2023 12:04:38

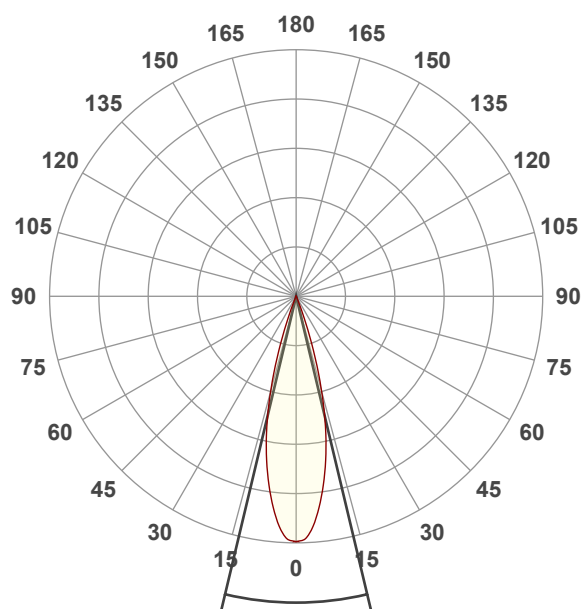

Spectra

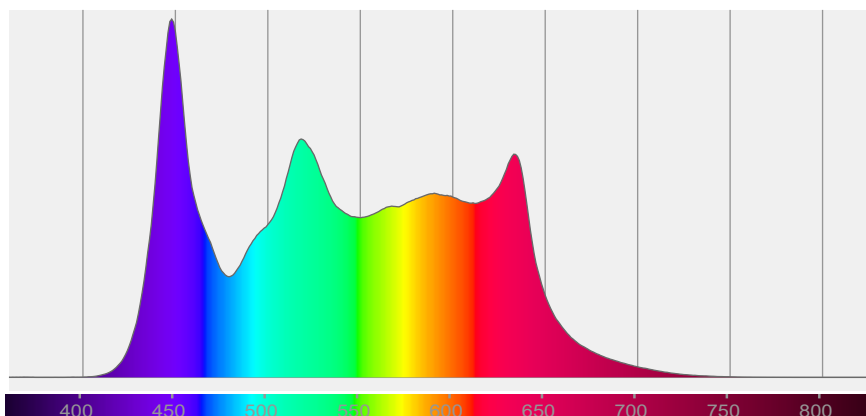

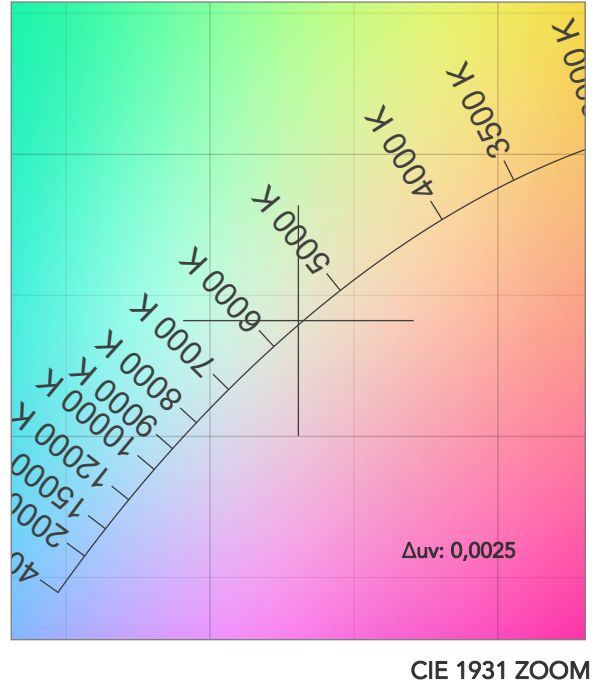
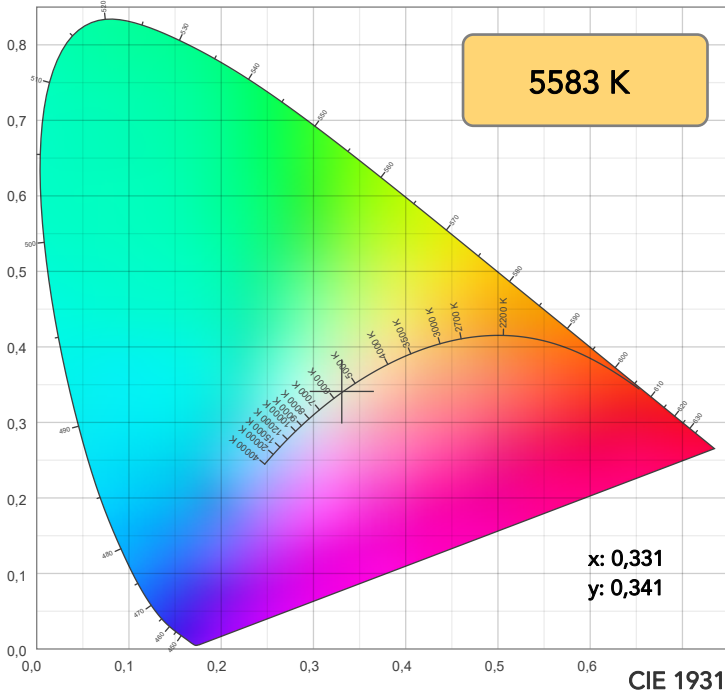

TM30: 93,1

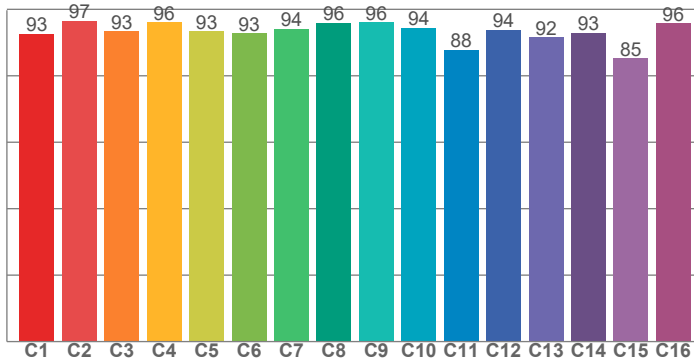

CRI: 95,7 (R1-R8)

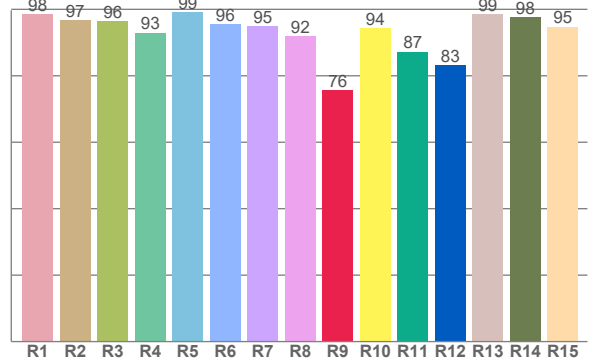

CQS: 94,6

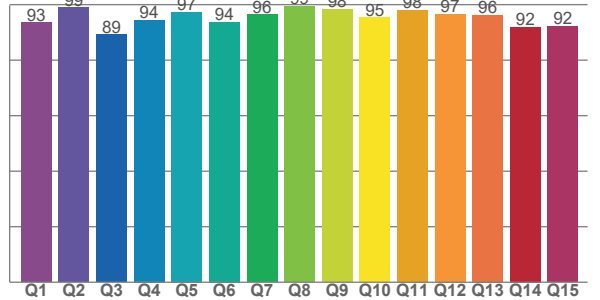

CRI R values, only R1-R8 are used to calculate final CRI value

R1	R2	R3	R4	R5	R6	R7	R8	R9	R10	R11	R12	R13	R14	R15
98,5	96,7	96,4	92,9	99,2	95,5	94,9	91,9	75,6	94,3	87,2	83,3	98,5	97,6	94,8

TM30 C values, 16 binned values out of total of 99 C values

C1	C2	C3	C4	C5	C6	C7	C8	C9	C10	C11	C12	C13	C14	C15	C16
92,6	96,6	93,4	96,1	93,4	92,7	94,2	95,9	96,0	94,4	87,9	93,8	91,6	93,0	85,3	95,8

CQS Q values

Q1	Q2	Q3	Q4	Q5	Q6	Q7	Q8	Q9	Q10	Q11	Q12	Q13	Q14	Q15
93,5	98,9	89,2	94,5	97,3	93,7	96,4	99,4	98,3	95,4	98,2	96,7	96,3	91,9	92,2

COLOR PARAMETERS

Color temperature	Color rendering index	Red component	Color fidelity	Color gamut	Color quality scale	Television lighting index	Color coordinate cie 1931	Color coordinate cie 1931	Color deviation from black body
CCT	CRI	CRI R9	TM30 Rf	TM30 Rg	CQS	TLCI	x	y	Δuv
5583 K	95,7	75,6	93,1	102,6	94,6	91	0,331	0,341	0,0025

# TM30 DETAILS

**Rf 93,1**  
Fidelity index Rf

**Rg 102,6**  
Gammut index

Hue Bin	R <sub>f</sub>	Graphic shifts (%)	
		Chroma	Hue
1	93	-3%	-1%
2	97	-1%	2%
3	93	-1%	3%
4	96	0%	2%
5	93	0%	2%
6	93	4%	3%
7	94	3%	1%
8	96	1%	0%
9	96	0%	1%
10	94	-1%	3%
11	88	2%	7%
12	94	3%	0%
13	92	5%	-4%
14	93	3%	-2%
15	85	6%	-12%
16	96	0%	-2%

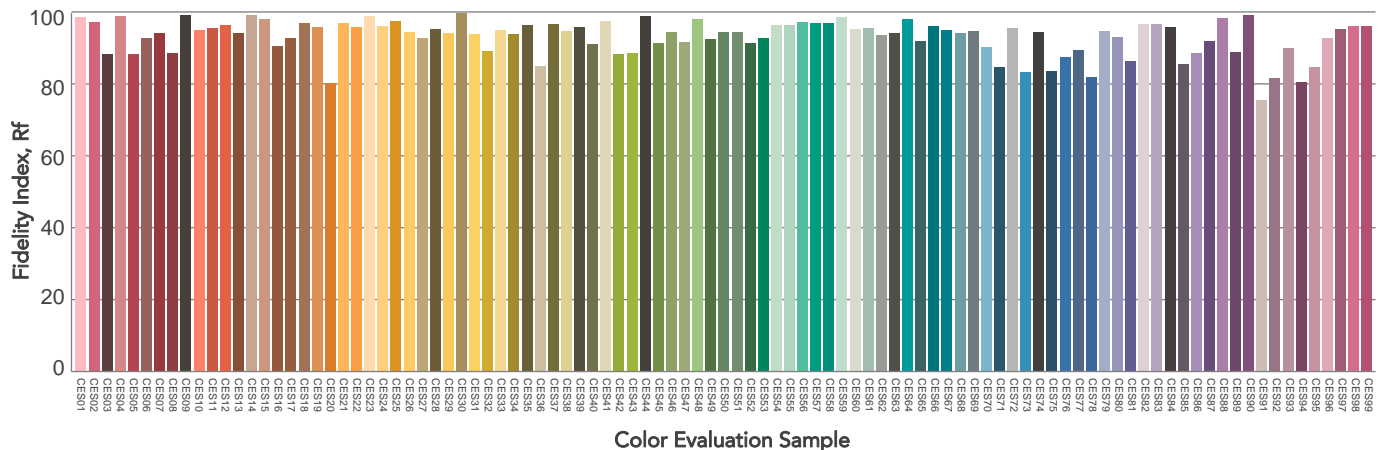
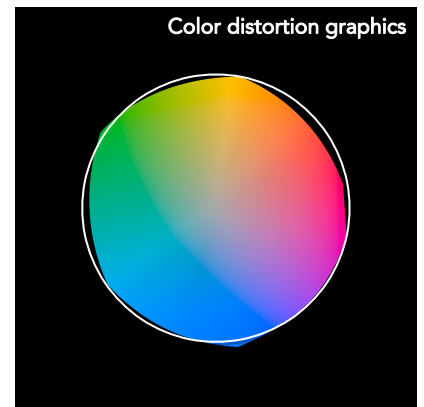
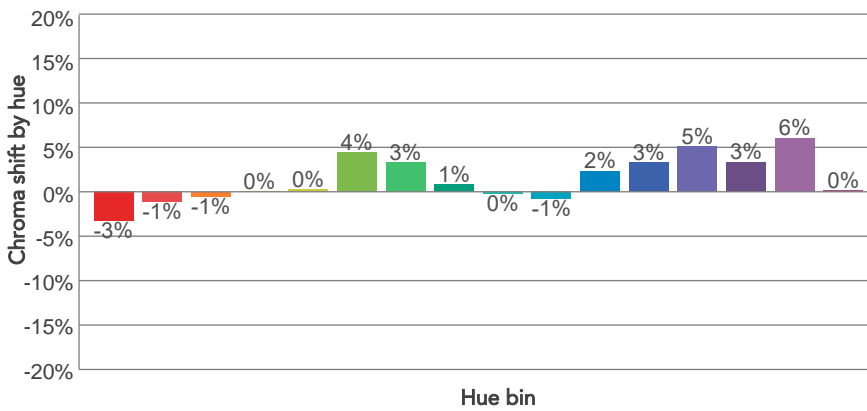
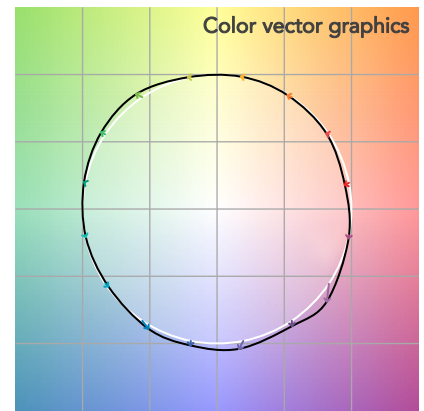
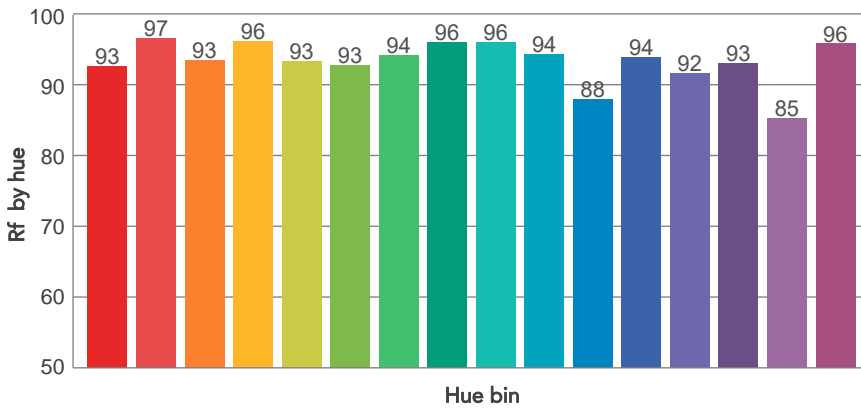
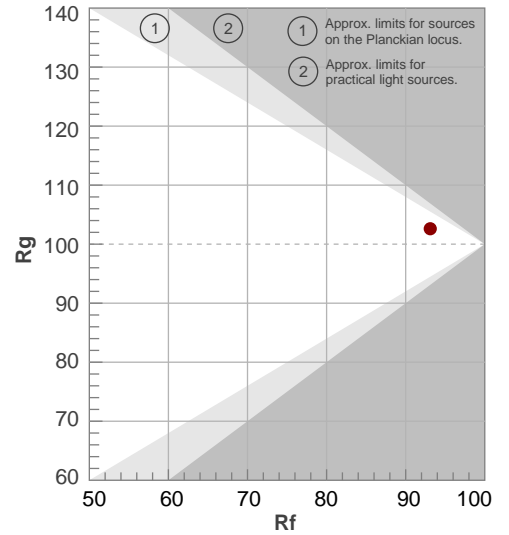



# BEAM DETAILS



Beam angle 50%	Field angle 10%	Cut off angle 2,5%	Intensity ratio in 120° cone	Intensity ratio in 90° cone
26,8°	40,2°	45,9°	100,0%	99,9%

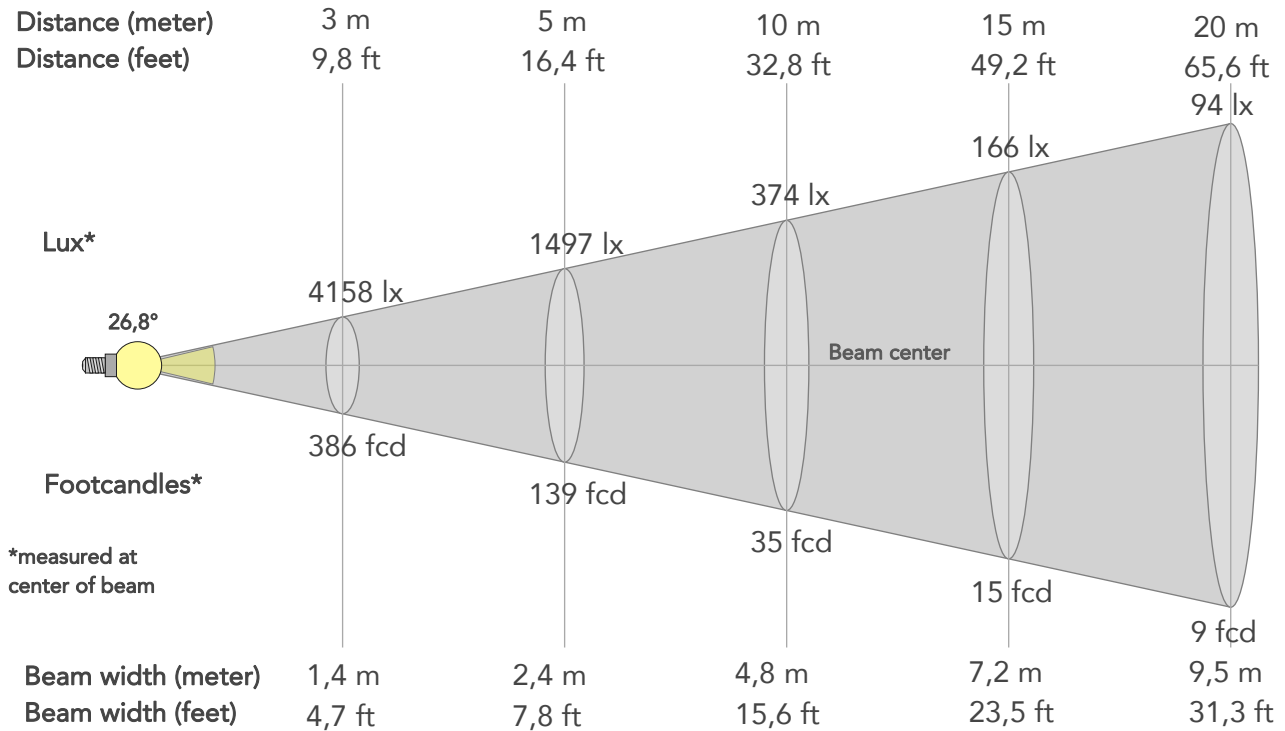

## BEAM INTENSITIES AND WIDTHS

Distance	1m	2m	3m	4m	5m	7,5m	10m	15m	20m	25m	30m	40m	50m
Distance	3,3ft	6,6ft	9,8ft	13,1ft	16,4ft	24,6ft	32,8ft	49,2ft	65,6ft	82ft	98,4ft	131,2ft	164ft
Lux	37419lx	9355lx	4158lx	2339lx	1497lx	665lx	374lx	166lx	94lx	60lx	42lx	23lx	15lx
Footcand.	3476fcd	869fcd	386fcd	217fcd	139fcd	62fcd	35fcd	15fcd	9fcd	6fcd	4fcd	2fcd	1fcd
Beam wid.	0,5m	1m	1,4m	1,9m	2,4m	3,6m	4,8m	7,2m	9,5m	11,9m	14,3m	19,1m	23,8m
Beam wid.	1,6ft	3,1ft	4,7ft	6,2ft	7,8ft	11,7ft	15,6ft	23,5ft	31,3ft	39,1ft	46,9ft	62,6ft	78,2ft

## LINEAR DISTRIBUTION DIAGRAM

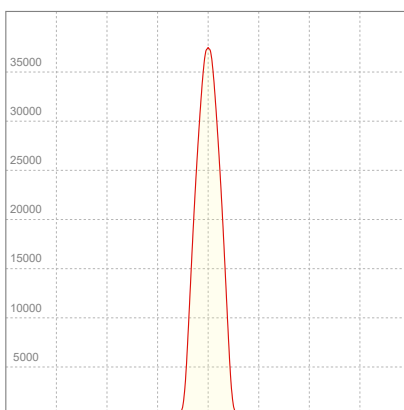

## ELECTRICAL SPECIFICATIONS

Input voltage	Input current	Input power	Effeciency
227V	1,38A	306,2W	24lm/W

## ISO CANDELA DIAGRAM

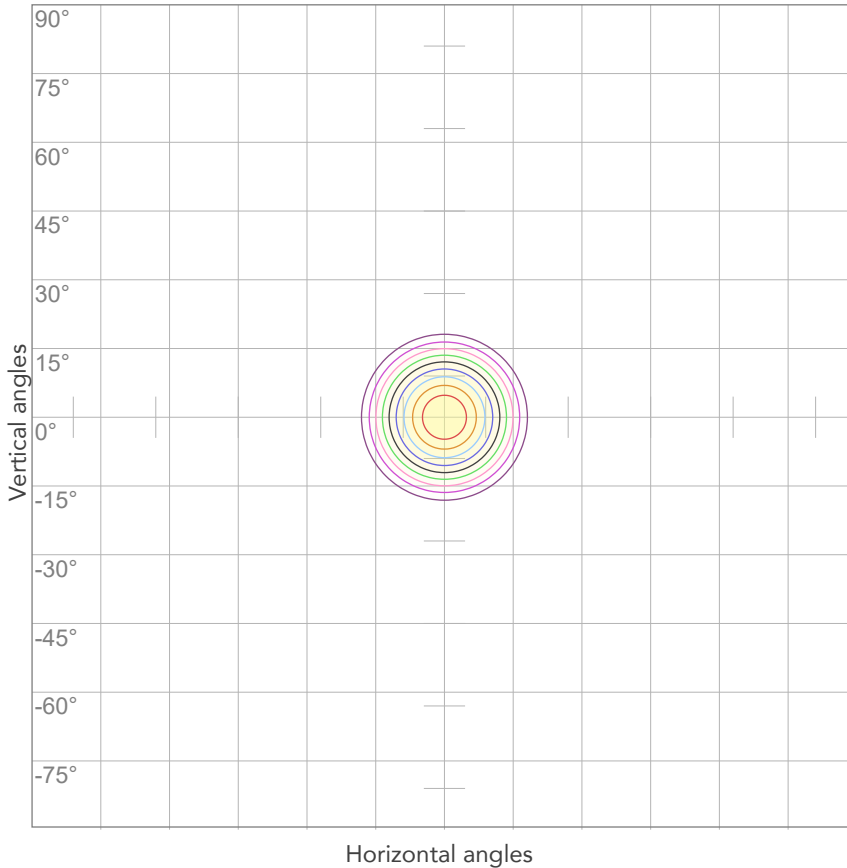

10%	3742 cd
20%	7484 cd
30%	11226 cd
40%	14967 cd
50%	18709 cd
60%	22451 cd
70%	26193 cd
80%	29935 cd

Conditions:

Number of c-planes: 2

Candela at center: 37419 cd

## ISO LUX DIAGRAM

MH: 10,0 m

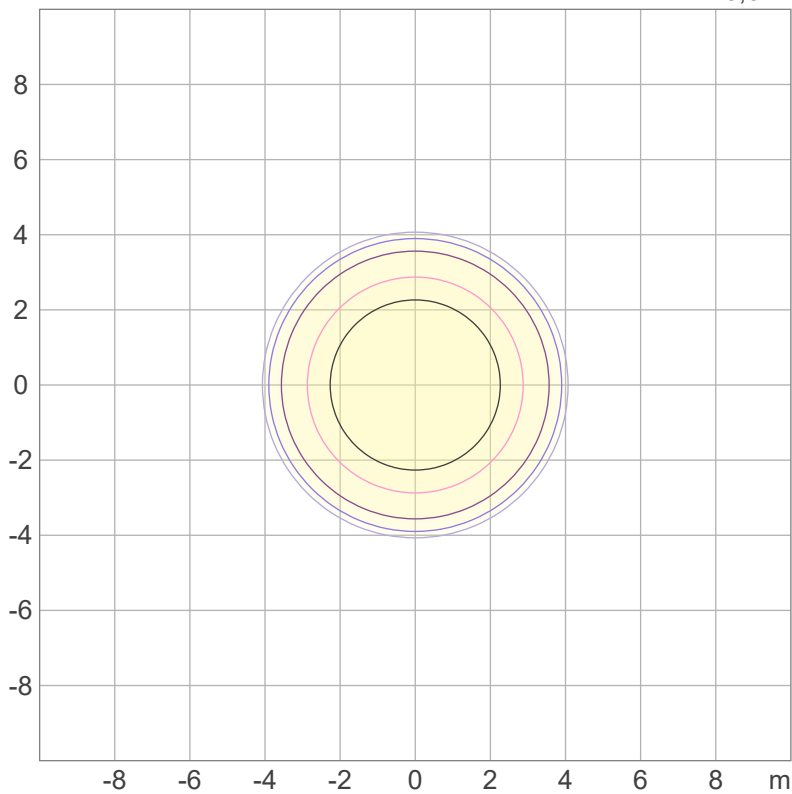

Mounting height: 10 meters (33 feet)

3%	11,2 lx
5%	18,7 lx
10%	37,4 lx
30%	112 lx
50%	187 lx

Conditions:

Number of c-planes: 2

Lux at center: 374 lx

*Lux distribution on a surface when lamp is mounted at 10 meters from the surface.*



Total lumen output:

3897 lm

Peak candela output:

137815 cd

Light quality:

CRI: 95,6

Color temperature:

5558 K

PRODUCT NAME:

ECLFRCTPM

MEASURAMENT CONDITIONS:

Beam angle:

Min Zoom

Target:

5600K - HB

Operator:

Salvatore Giglio

Date and time:

03/10/2023 11:33:46

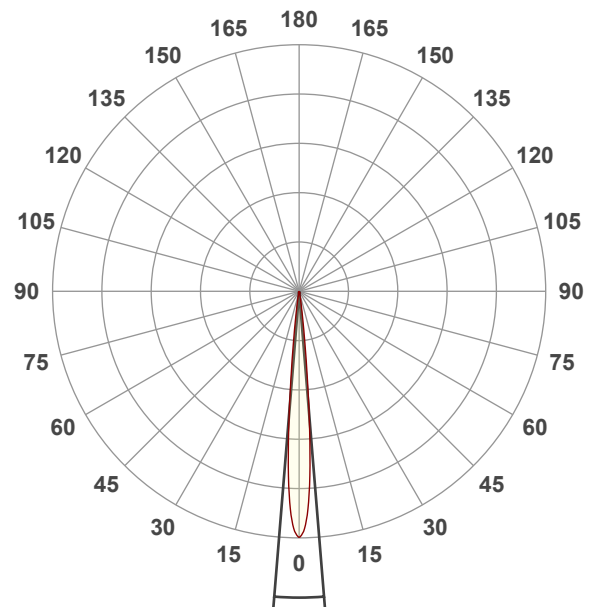

Beam angle 50%: 9,3°

Field angle 10%: 15,4°

Cut off angle 2.5%: 20,5°

Spectra

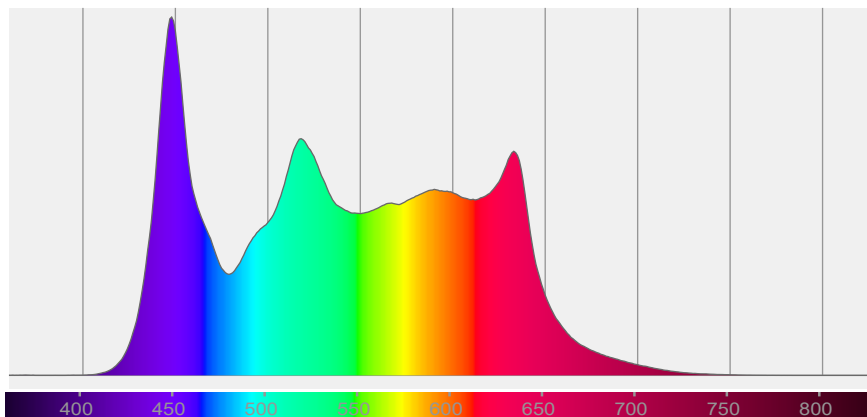

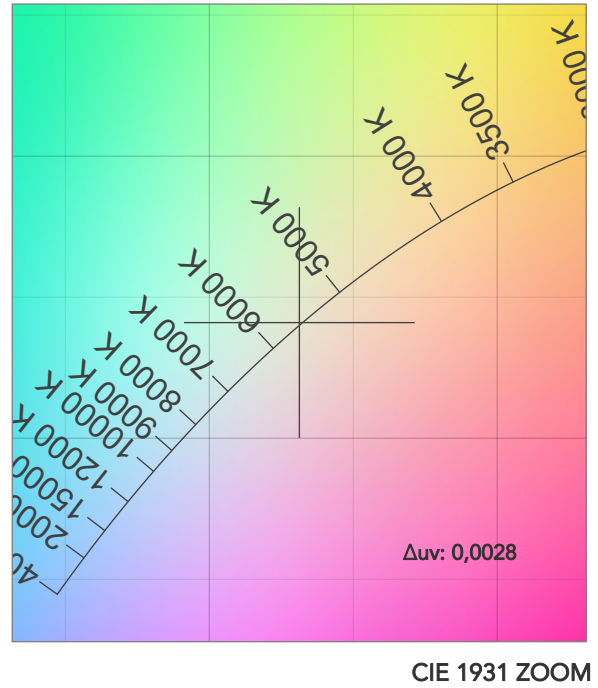
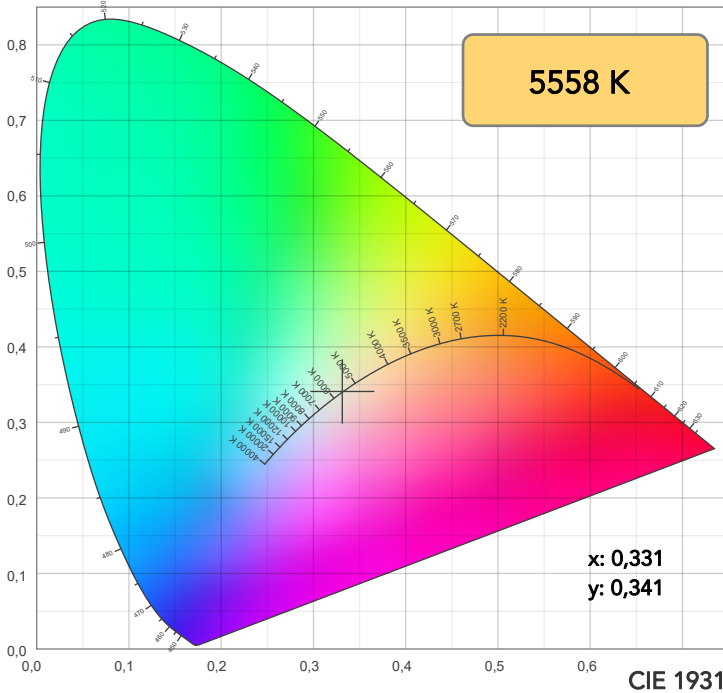

TM30: 93,0

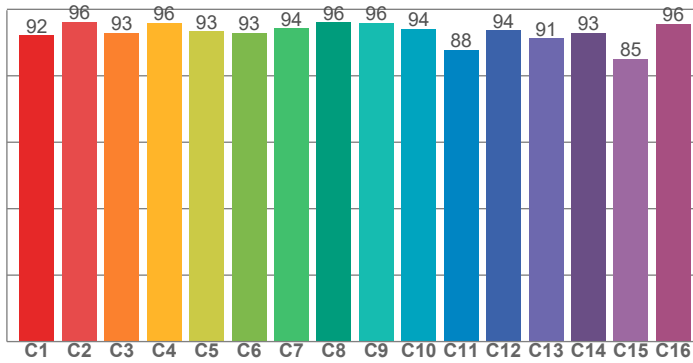

CRI: 95,6 (R1-R8)

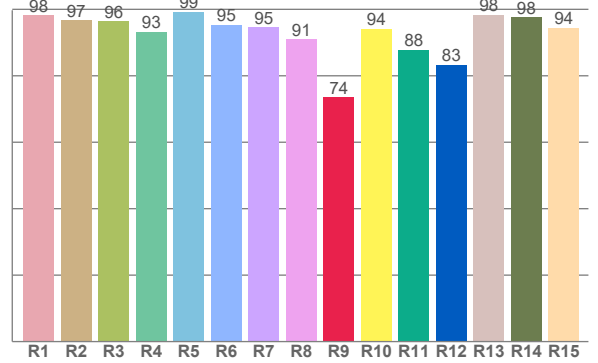

CQS: 94,4

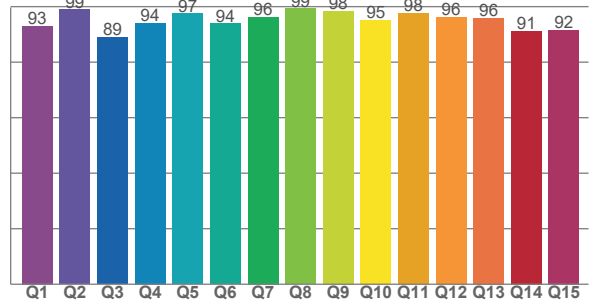

CRI R values, only R1-R8 are used to calculate final CRI value

R1	R2	R3	R4	R5	R6	R7	R8	R9	R10	R11	R12	R13	R14	R15
98,3	96,7	96,5	93,3	99,2	95,4	94,6	91,1	73,5	94,2	87,8	83,4	98,3	97,7	94,5

TM30 C values, 16 binned values out of total of 99 C values

C1	C2	C3	C4	C5	C6	C7	C8	C9	C10	C11	C12	C13	C14	C15	C16
92,2	96,3	93,0	95,9	93,3	92,8	94,3	96,0	96,0	94,1	87,8	93,7	91,3	92,9	85,0	95,7

CQS Q values

Q1	Q2	Q3	Q4	Q5	Q6	Q7	Q8	Q9	Q10	Q11	Q12	Q13	Q14	Q15
93,0	98,9	89,0	94,0	97,4	93,9	96,3	99,3	98,4	95,2	97,7	96,2	95,8	91,1	91,5

COLOR PARAMETERS

Color temperature	Color rendering index	Red component	Color fidelity	Color gamut	Color quality scale	Television lighting index	Color coordinate cie 1931	Color coordinate cie 1931	Color deviation from black body
CCT	CRI	CRI R9	TM30 Rf	TM30 Rg	CQS	TLCI	x	y	Δuv
5558 K	95,6	73,5	93,0	102,5	94,4	90	0,331	0,341	0,0028

# TM30 DETAILS

**Rf 93,0**  
Fidelity index Rf

**Rg 102,5**  
Gammut index

Hue Bin	R <sub>f</sub>	Graphic shifts (%)	
		Chroma	Hue
1	92	-4%	-1%
2	96	-1%	2%
3	93	-1%	4%
4	96	0%	2%
5	93	0%	2%
6	93	4%	3%
7	94	3%	0%
8	96	1%	0%
9	96	0%	1%
10	94	-1%	3%
11	88	2%	7%
12	94	3%	0%
13	91	5%	-5%
14	93	3%	-2%
15	85	6%	-12%
16	96	0%	-2%

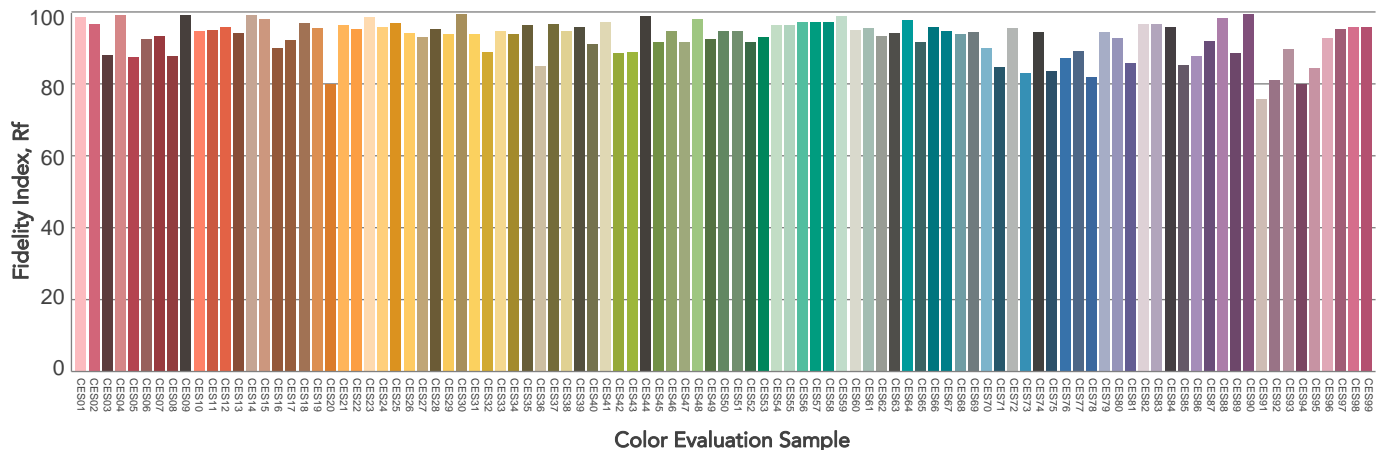
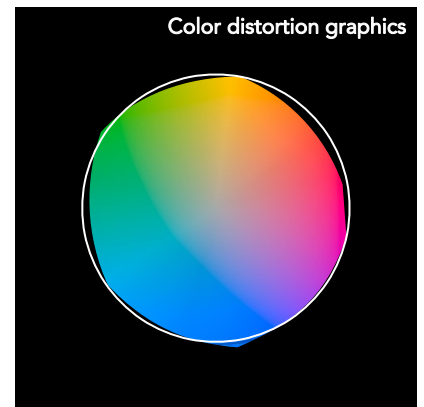
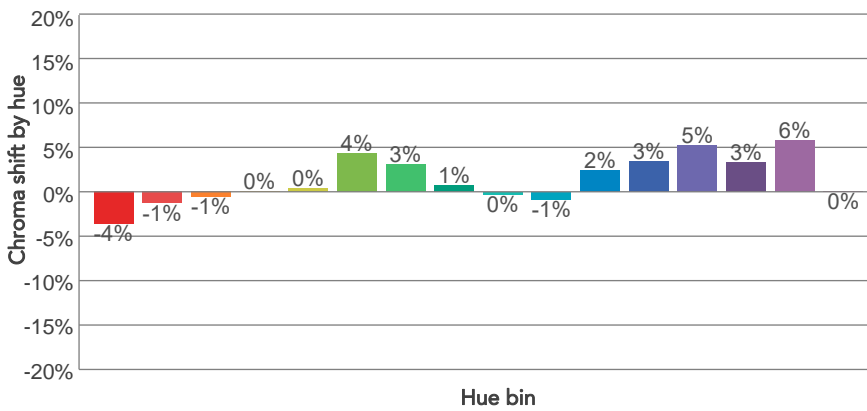
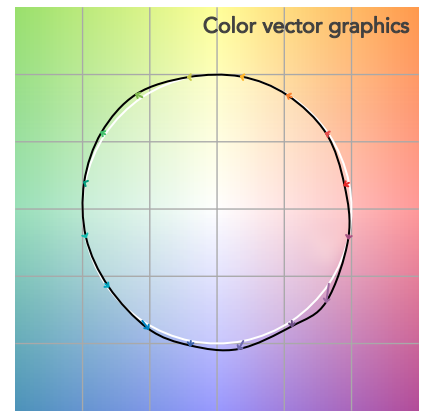
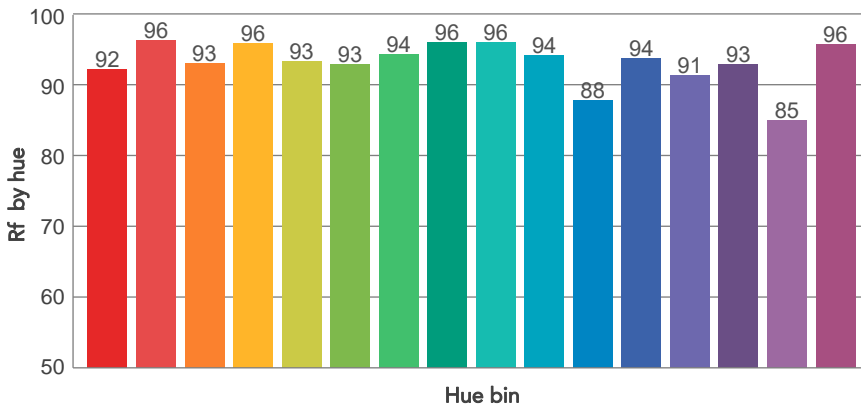
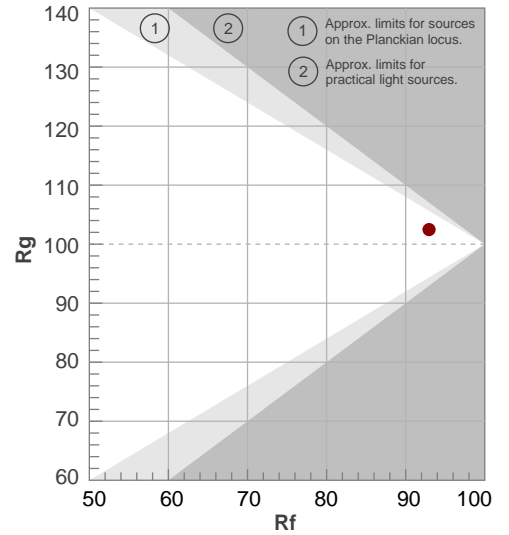

# BEAM DETAILS



Beam angle 50%	Field angle 10%	Cut off angle 2,5%	Intensity ratio in 120° cone	Intensity ratio in 90° cone
9,3°	15,4°	20,5°	100,0%	100,0%

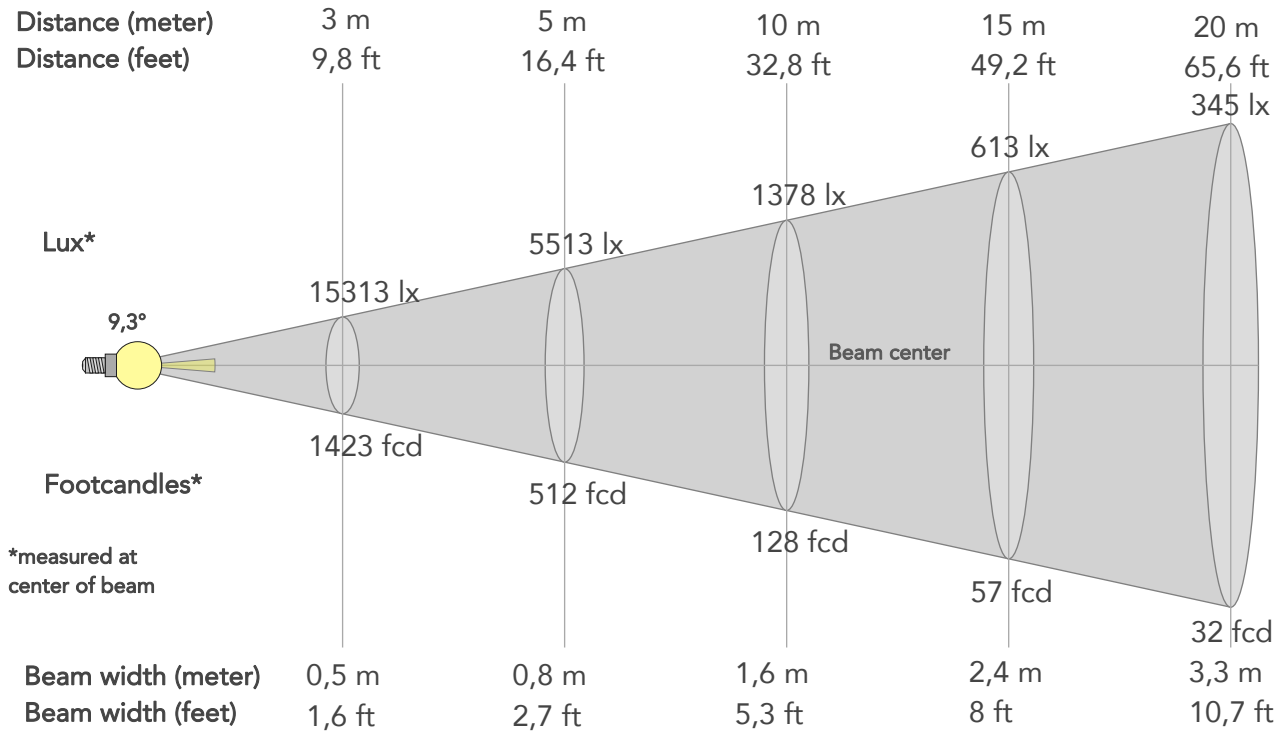

## BEAM INTENSITIES AND WIDTHS

Distance	1m	2m	3m	4m	5m	7,5m	10m	15m	20m	25m	30m	40m	50m
Distance	3,3ft	6,6ft	9,8ft	13,1ft	16,4ft	24,6ft	32,8ft	49,2ft	65,6ft	82ft	98,4ft	131,2ft	164ft
Lux	137815lx	34454lx	15313lx	8613lx	5513lx	2450lx	1378lx	613lx	345lx	221lx	153lx	86lx	55lx
Footcand.	12803fcd	3201fcd	1423fcd	800fcd	512fcd	228fcd	128fcd	57fcd	32fcd	20fcd	14fcd	8fcd	5fcd
Beam wid.	0,2m	0,3m	0,5m	0,7m	0,8m	1,2m	1,6m	2,4m	3,3m	4,1m	4,9m	6,5m	8,2m
Beam wid.	0,5ft	1,1ft	1,6ft	2,1ft	2,7ft	4ft	5,3ft	8ft	10,7ft	13,4ft	16ft	21,4ft	26,7ft

## LINEAR DISTRIBUTION DIAGRAM

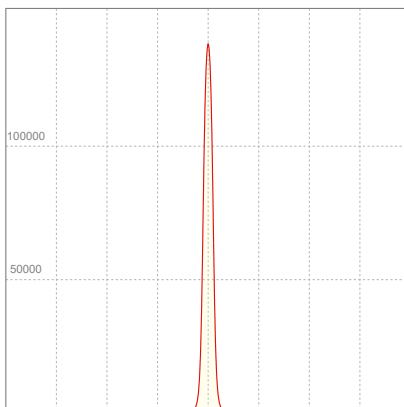

## ELECTRICAL SPECIFICATIONS

Input voltage	Input current	Input power	Effeciency
227V	1,37A	305,1W	13lm/W

## ISO CANDELA DIAGRAM

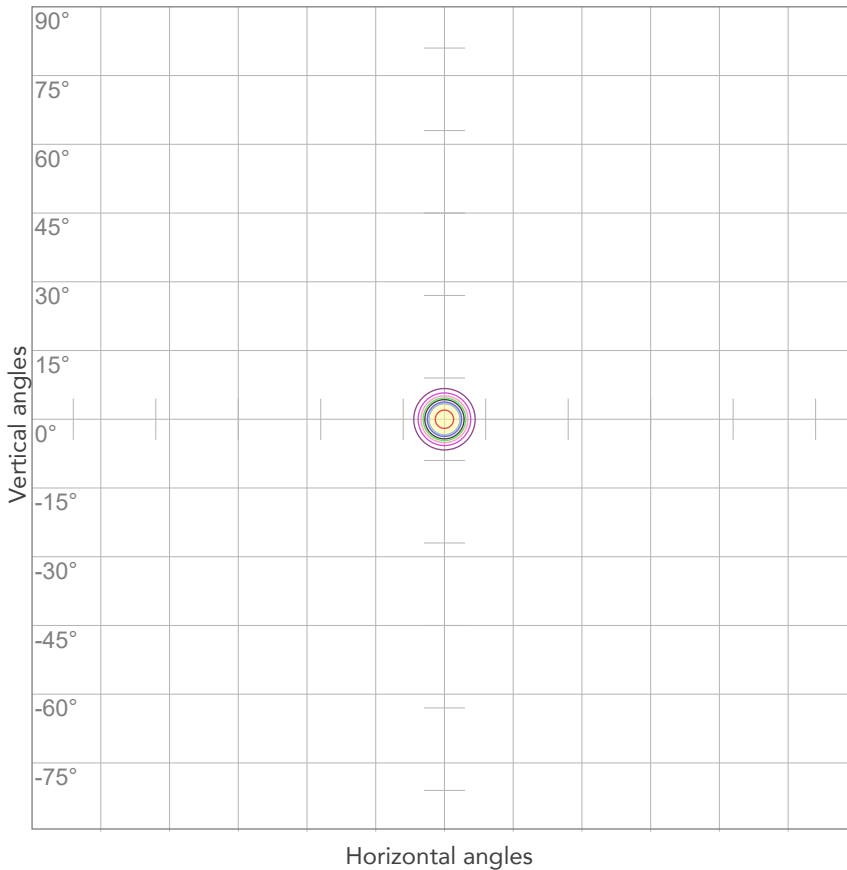

10%	13782 cd
20%	27563 cd
30%	41345 cd
40%	55126 cd
50%	68908 cd
60%	82689 cd
70%	96471 cd
80%	110252 cd

Conditions:

Number of c-planes: 2

Candela at center: 137815 cd

## ISO LUX DIAGRAM

MH: 10,0 m

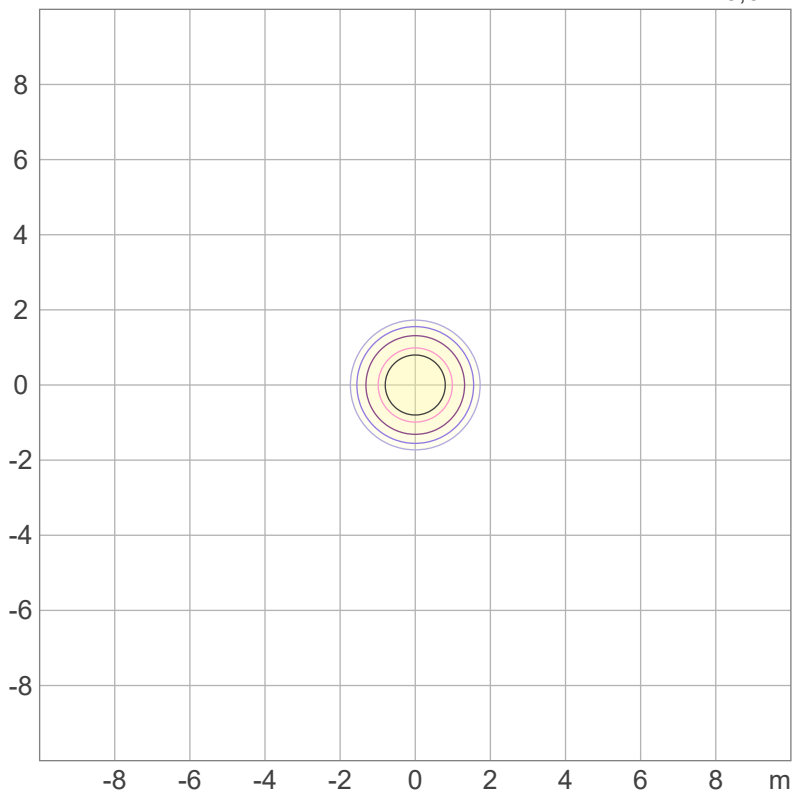

3%	41,3 lx
5%	68,9 lx
10%	138 lx
30%	413 lx
50%	689 lx

Conditions:

Number of c-planes: 2

Lux at center: 1378 lx

*Lux distribution on a surface when lamp is mounted at 10 meters from the surface.*



Total lumen output:

9250 lm

Peak candela output:

10521 cd

Light quality:

CRI: 95,6

Color temperature:

6082 K

PRODUCT NAME:

ECLFRCTPM

MEASURAMENT CONDITIONS:

Beam angle:

Max Zoom

Target:

6000K - HB

Operator:

Salvatore Giglio

Date and time:

03/10/2023 10:31:07

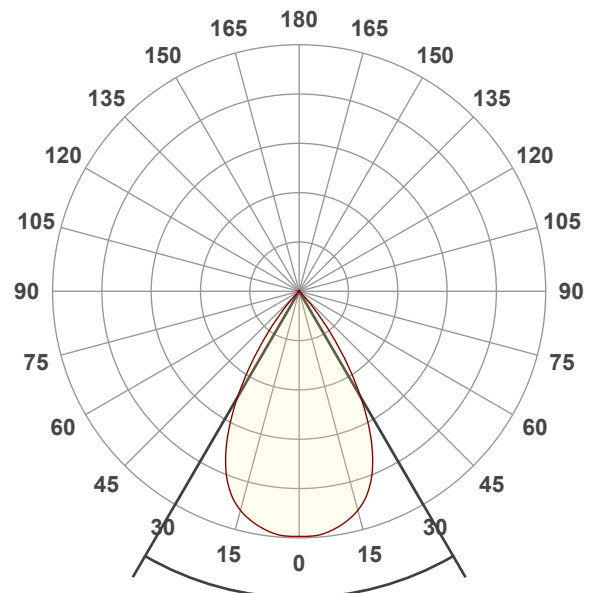

Beam angle 50%: 60,4°

Field angle 10%: 81,1°

Cut off angle 2.5%: 88,8°

Spectra

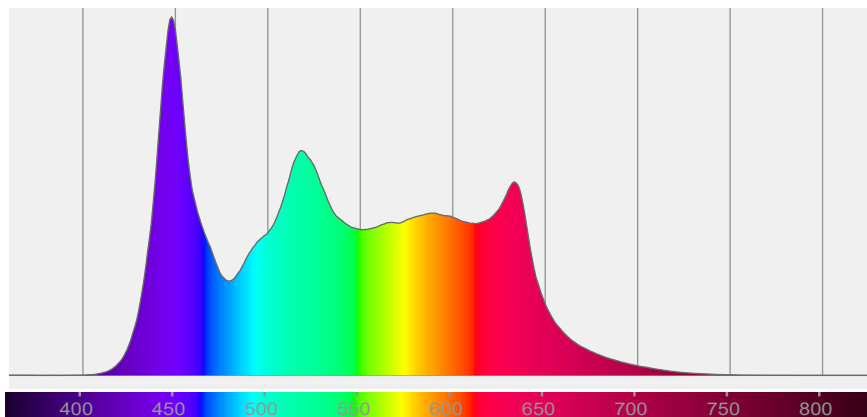



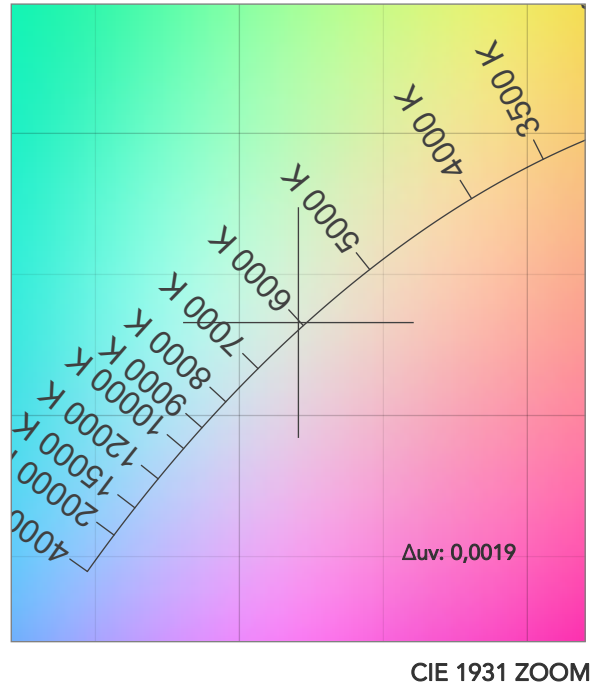
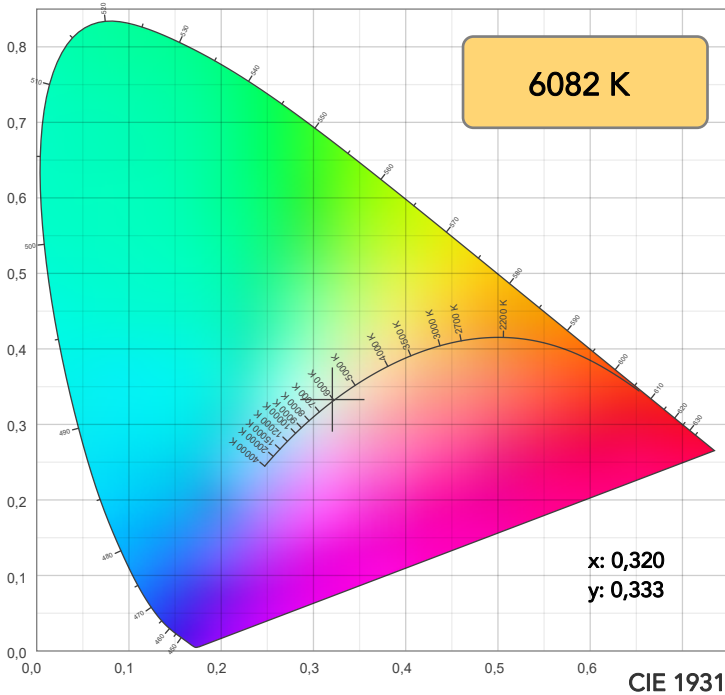

TM30: 93,0

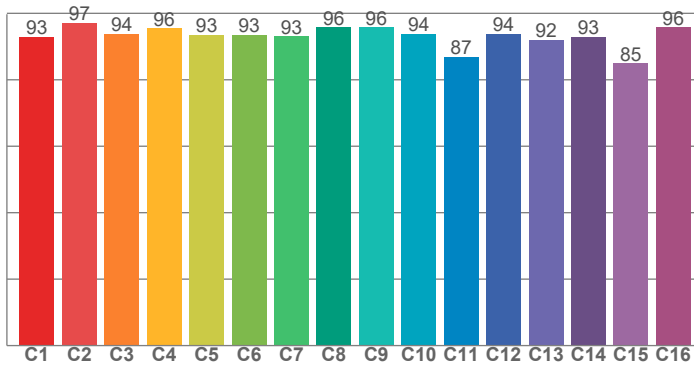

CRI: 95,6 (R1-R8)

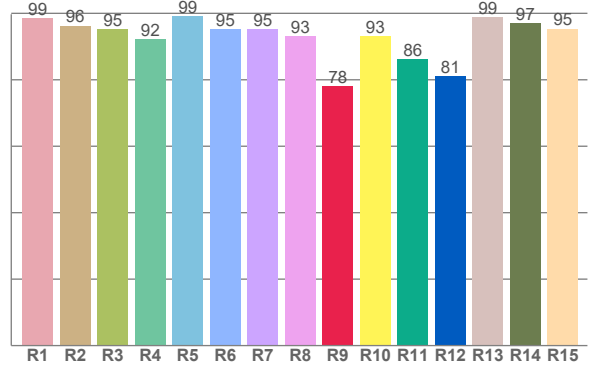

CRI R values, only R1-R8 are used to calculate final CRI value

R1	R2	R3	R4	R5	R6	R7	R8	R9	R10	R11	R12	R13	R14	R15
98,6	96,3	95,2	92,2	99,2	95,2	95,1	93,1	78,1	93,1	86,2	81,0	98,7	97,0	95,3

TM30 C values, 16 binned values out of total of 99 C values

C1	C2	C3	C4	C5	C6	C7	C8	C9	C10	C11	C12	C13	C14	C15	C16
93,0	97,1	93,9	95,5	93,4	93,5	93,1	95,8	95,8	93,8	86,9	93,9	92,0	92,8	85,0	95,7

CQS Q values

Q1	Q2	Q3	Q4	Q5	Q6	Q7	Q8	Q9	Q10	Q11	Q12	Q13	Q14	Q15
94,3	98,6	88,6	94,0	97,2	93,6	96,5	99,3	97,7	95,2	98,5	97,5	97,3	92,8	93,1

CQS: 94,8

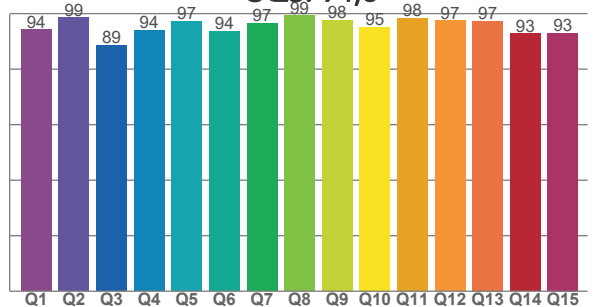

COLOR PARAMETERS

Color temperature	Color rendering index	Red component	Color fidelity	Color gamut	Color quality scale	Television lighting index	Color coordinate cie 1931	Color coordinate cie 1931	Color deviation from black body
CCT	CRI	CRI R9	TM30 Rf	TM30 Rg	CQS	TLCI	x	y	Δuv
6082 K	95,6	78,1	93,0	102,8	94,8	91	0,320	0,333	0,0019

# TM30 DETAILS

**Rf 93,0**  
Fidelity index Rf

**Rg 102,8**  
Gammut index

Hue Bin	R <sub>f</sub>	Graphic shifts (%)	
		Chroma	Hue
1	93	-3%	-1%
2	97	-1%	1%
3	94	0%	3%
4	96	0%	2%
5	93	0%	2%
6	93	4%	2%
7	93	5%	1%
8	96	1%	0%
9	96	-1%	2%
10	94	-1%	3%
11	87	2%	8%
12	94	3%	1%
13	92	5%	-3%
14	93	4%	-1%
15	85	7%	-12%
16	96	1%	-2%

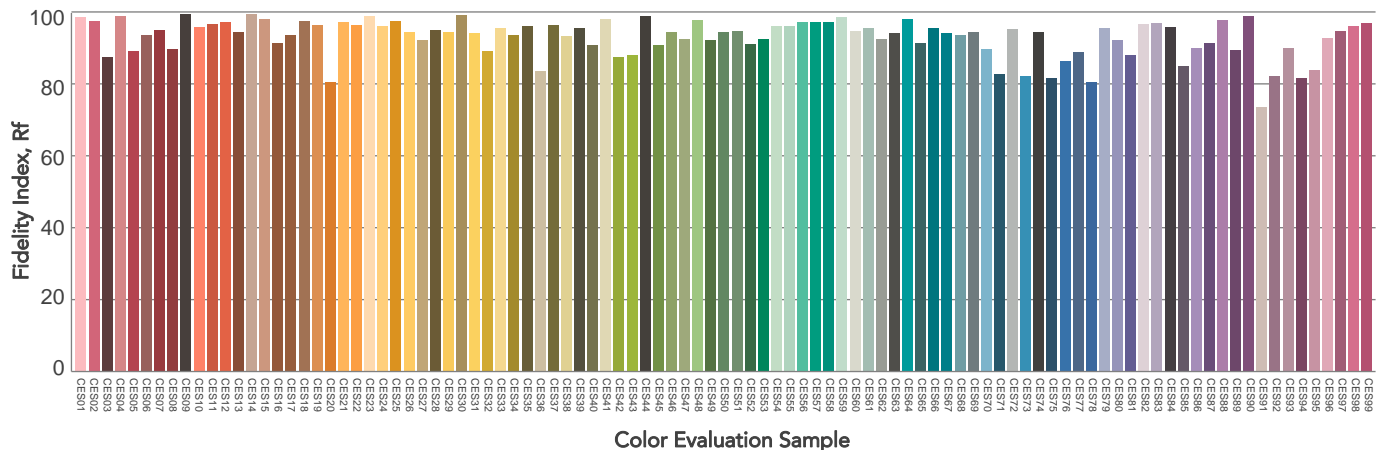
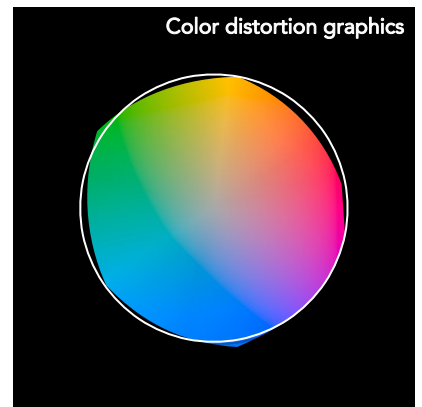
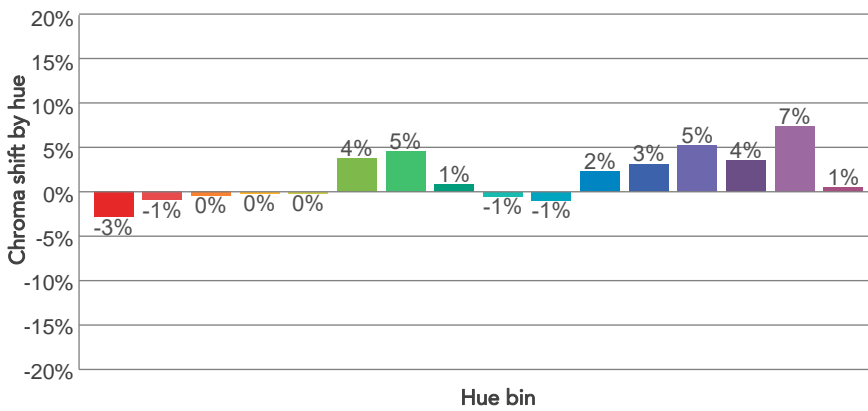
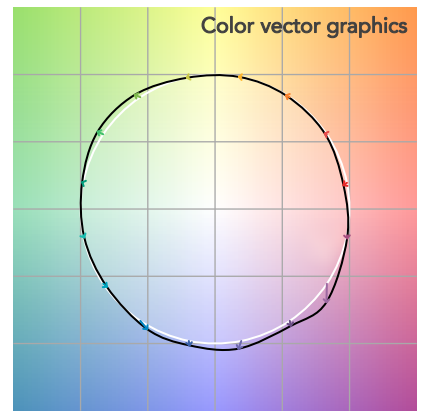
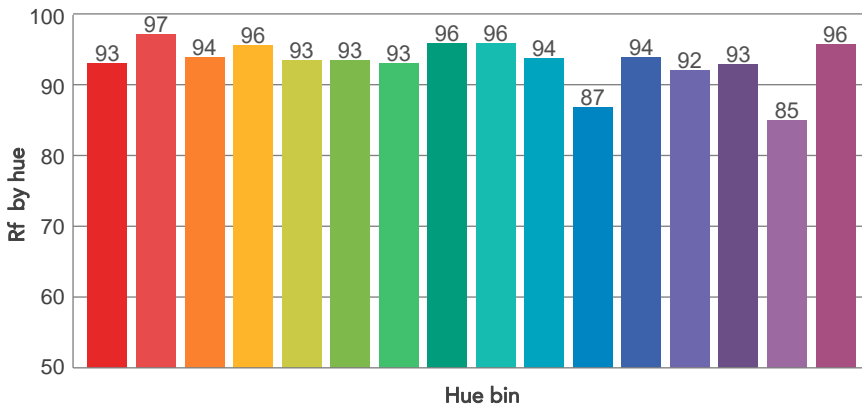
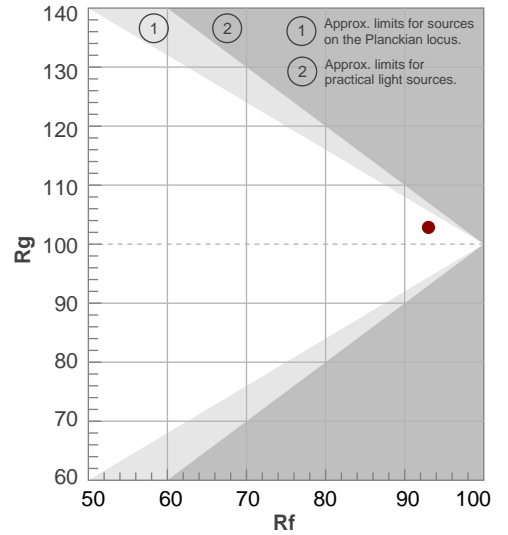

# BEAM DETAILS



Beam angle 50%	Field angle 10%	Cut off angle 2,5%	Intensity ratio in 120° cone	Intensity ratio in 90° cone
60,4°	81,1°	88,8°	99,9%	99,4%

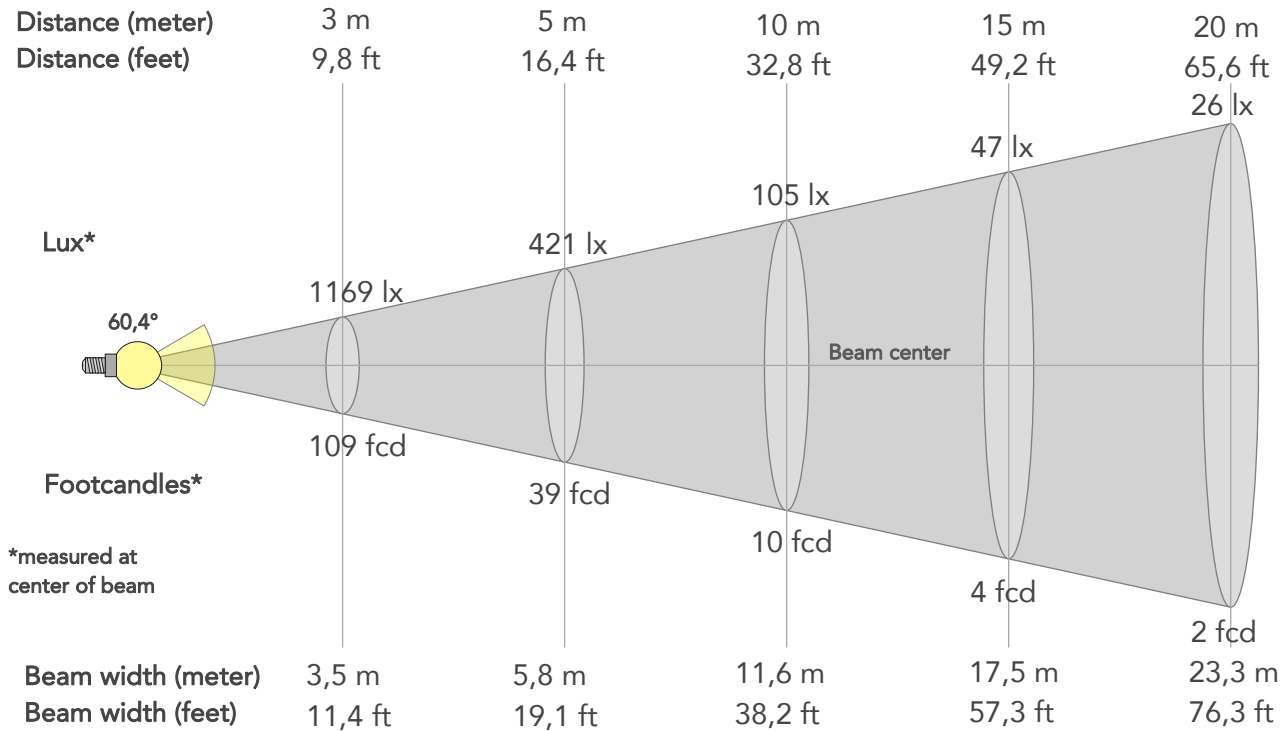

## BEAM INTENSITIES AND WIDTHS

Distance	1m	2m	3m	4m	5m	7,5m	10m	15m	20m	25m	30m	40m	50m
Distance	3,3ft	6,6ft	9,8ft	13,1ft	16,4ft	24,6ft	32,8ft	49,2ft	65,6ft	82ft	98,4ft	131,2ft	164ft
Lux	10521lx	2630lx	1169lx	658lx	421lx	187lx	105lx	47lx	26lx	17lx	12lx	7lx	4lx
Footcand.	977fcd	244fcd	109fcd	61fcd	39fcd	17fcd	10fcd	4fcd	2fcd	2fcd	1fcd	1fcd	0fcd
Beam wid.	1,2m	2,3m	3,5m	4,7m	5,8m	8,7m	11,6m	17,5m	23,3m	29,1m	34,9m	46,5m	58,2m
Beam wid.	3,8ft	7,7ft	11,4ft	15,2ft	19,1ft	28,6ft	38,2ft	57,3ft	76,3ft	95,4ft	114,5ft	152,7ft	190,9ft

## LINEAR DISTRIBUTION DIAGRAM

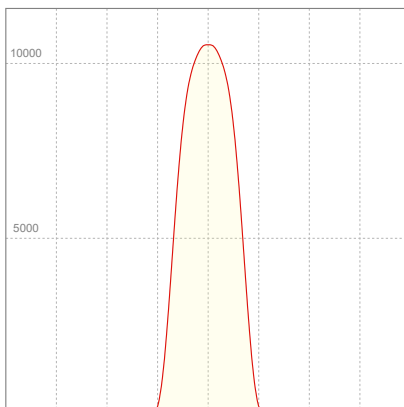

## ELECTRICAL SPECIFICATIONS

Input voltage	Input current	Input power	Effeciency
225V	1,36A	299,5W	31lm/W

## ISO CANDELA DIAGRAM

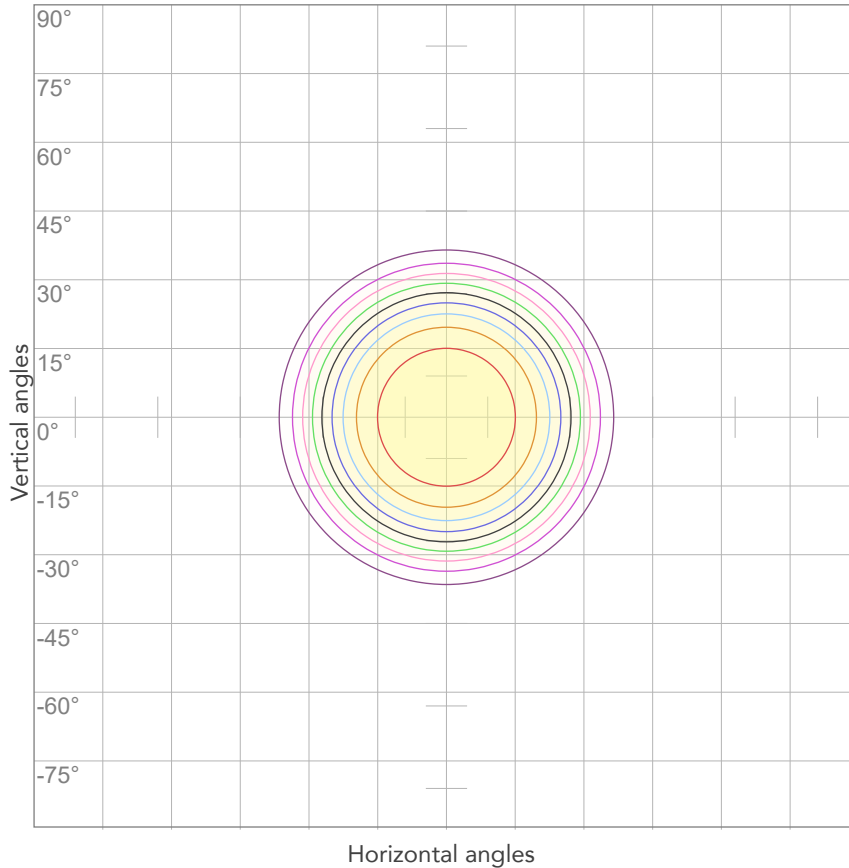

10%	1052 cd
20%	2104 cd
30%	3156 cd
40%	4209 cd
50%	5261 cd
60%	6313 cd
70%	7365 cd
80%	8417 cd

Conditions:

Number of c-planes: 2

Candela at center: 10521 cd

## ISO LUX DIAGRAM

MH: 10,0 m

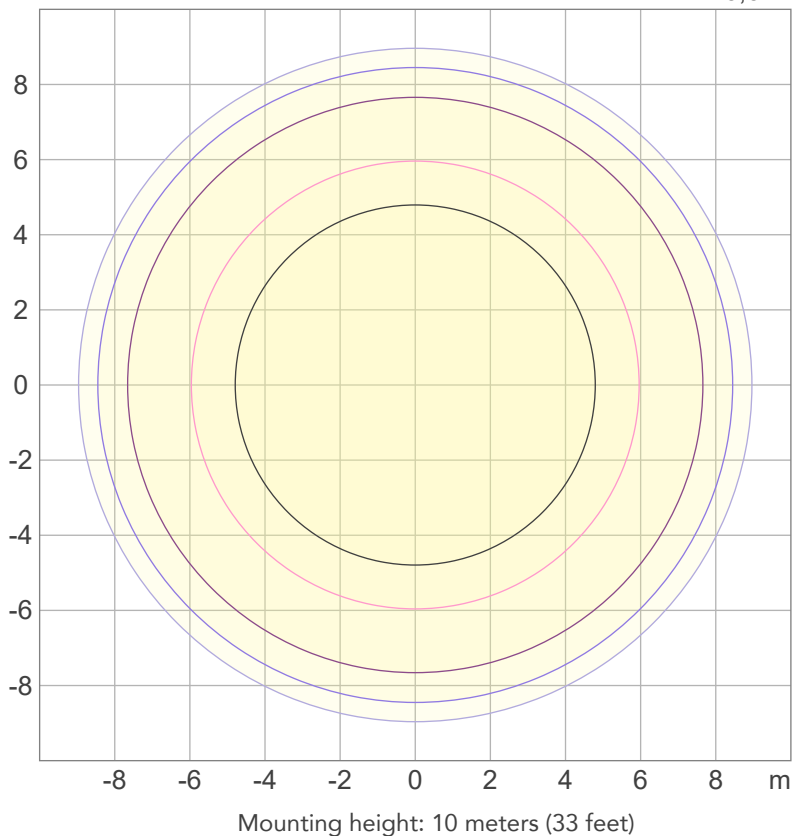

3%	3,16 lx
5%	5,26 lx
10%	10,5 lx
30%	31,6 lx
50%	52,6 lx

Conditions:

Number of c-planes: 2

Lux at center: 105 lx

*Lux distribution on a surface when lamp is mounted at 10 meters from the surface.*



Total lumen output:

6977 lm

Peak candela output:

36441 cd

Light quality:

CRI: 95,6

Color temperature:

6079 K

PRODUCT NAME:

ECLFRCTPM

MEASURAMENT CONDITIONS:

Beam angle:

Med Zoom

Target:

6000K - HB

Operator:

Salvatore Giglio

Date and time:

03/10/2023 12:06:05

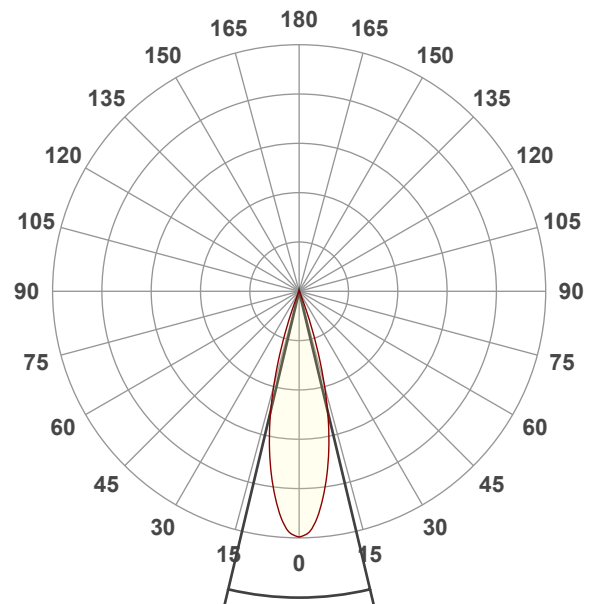

Beam angle 50%: 26,8°

Field angle 10%: 40,3°

Cut off angle 2.5%: 45,4°

Spectra

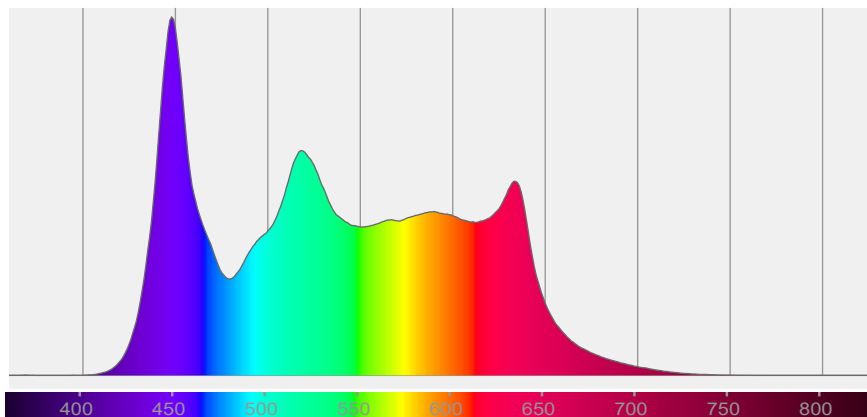

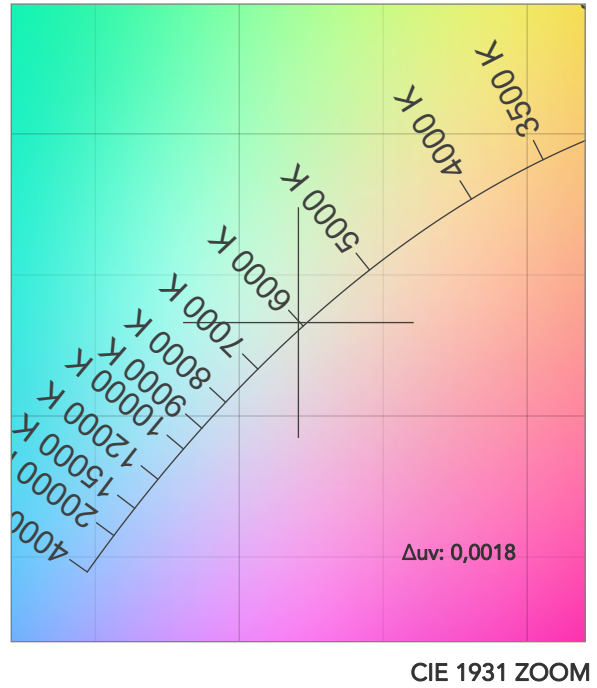
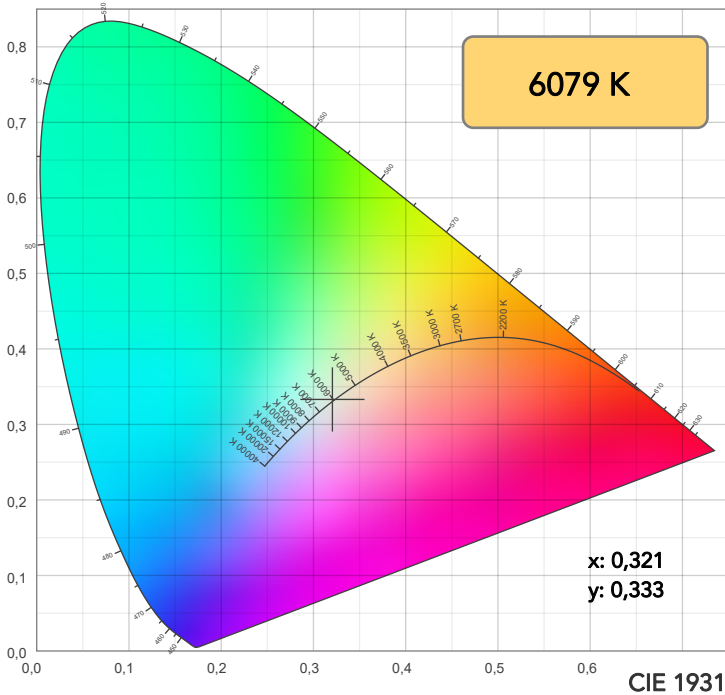

TM30: 93,0

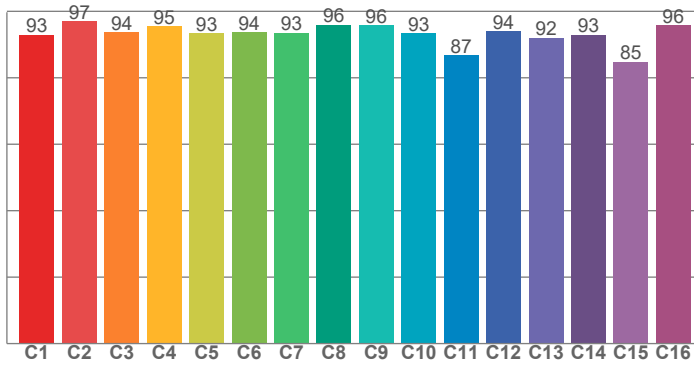

CRI: 95,6 (R1-R8)

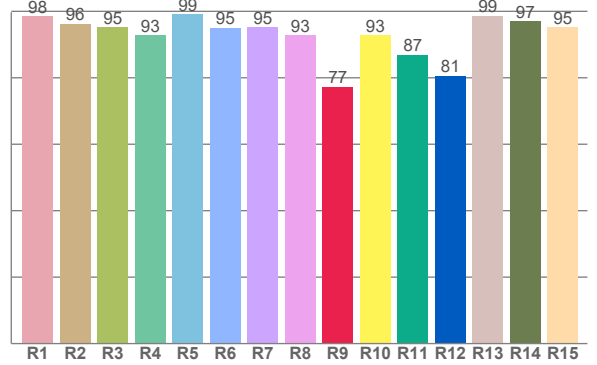

CRI R values, only R1-R8 are used to calculate final CRI value

R1	R2	R3	R4	R5	R6	R7	R8	R9	R10	R11	R12	R13	R14	R15
98,5	96,3	95,3	92,7	99,2	95,1	95,2	92,9	77,3	92,9	87,0	80,6	98,6	97,1	95,1

TM30 C values, 16 binned values out of total of 99 C values

C1	C2	C3	C4	C5	C6	C7	C8	C9	C10	C11	C12	C13	C14	C15	C16
92,9	97,0	93,7	95,4	93,4	93,7	93,5	96,0	95,8	93,4	86,8	93,9	92,0	92,9	84,8	95,8

CQS Q values

Q1	Q2	Q3	Q4	Q5	Q6	Q7	Q8	Q9	Q10	Q11	Q12	Q13	Q14	Q15
94,1	98,7	88,5	93,5	97,5	94,0	96,5	99,4	97,8	95,1	98,2	97,2	97,1	92,5	92,9

CQS: 94,7

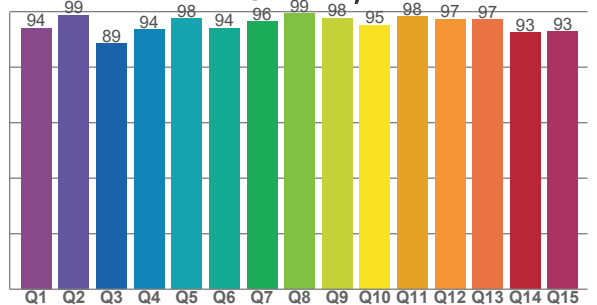

COLOR PARAMETERS

Color temperature	Color rendering index	Red component	Color fidelity	Color gamut	Color quality scale	Television lighting index	Color coordinate cie 1931	Color coordinate cie 1931	Color deviation from black body
CCT	CRI	CRI R9	TM30 Rf	TM30 Rg	CQS	TLCI	x	y	Δuv
6079 K	95,6	77,3	93,0	102,6	94,7	91	0,321	0,333	0,0018

# TM30 DETAILS



**Rf 93,0**  
Fidelity index Rf

**Rg 102,6**  
Gammut index

Hue Bin	R <sub>f</sub>	Graphic shifts (%)	
		Chroma	Hue
1	93	-3%	-1%
2	97	-1%	1%
3	94	-1%	3%
4	95	0%	2%
5	93	0%	2%
6	94	4%	2%
7	93	4%	1%
8	96	1%	0%
9	96	-1%	2%
10	93	-1%	4%
11	87	2%	8%
12	94	3%	1%
13	92	5%	-3%
14	93	3%	-2%
15	85	7%	-12%
16	96	0%	-2%

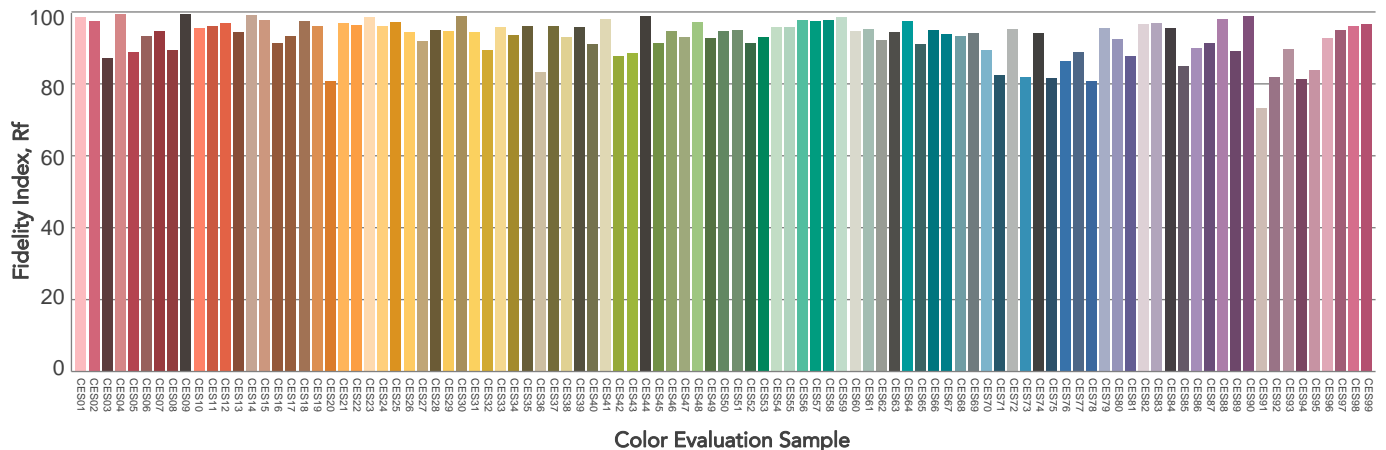
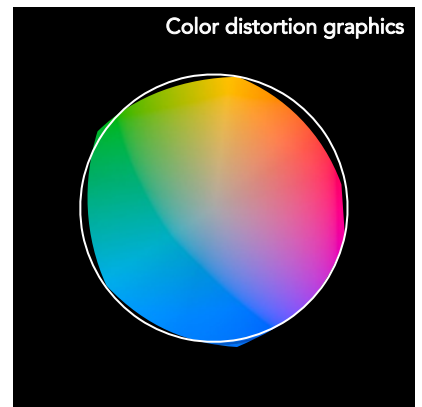
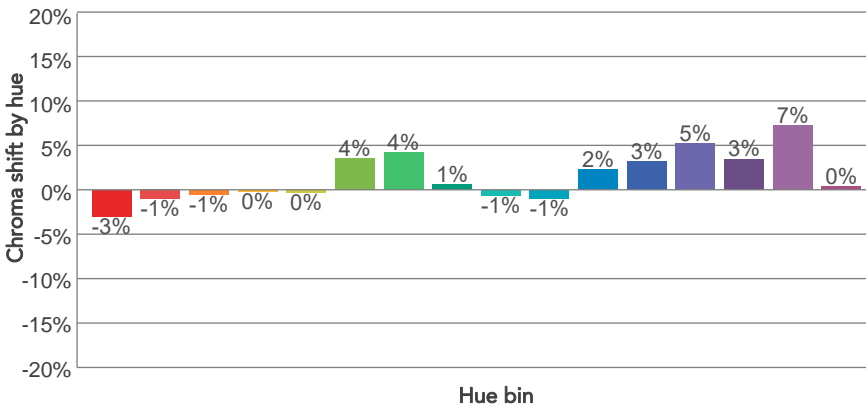
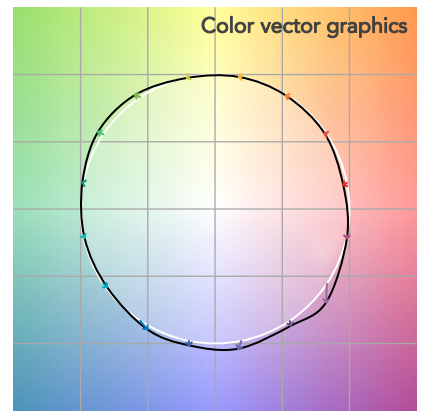
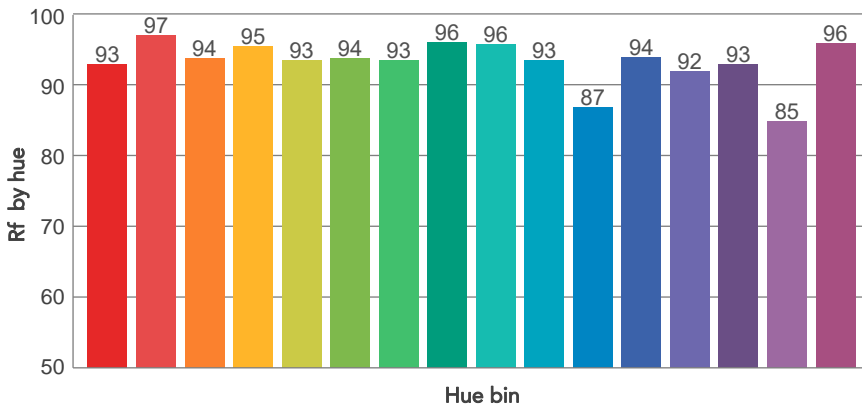
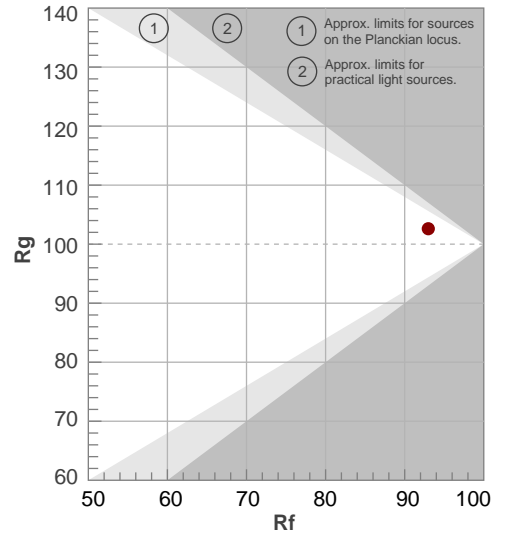

# BEAM DETAILS



Beam angle 50%	Field angle 10%	Cut off angle 2,5%	Intensity ratio in 120° cone	Intensity ratio in 90° cone
26,8°	40,3°	45,4°	100,0%	100,0%

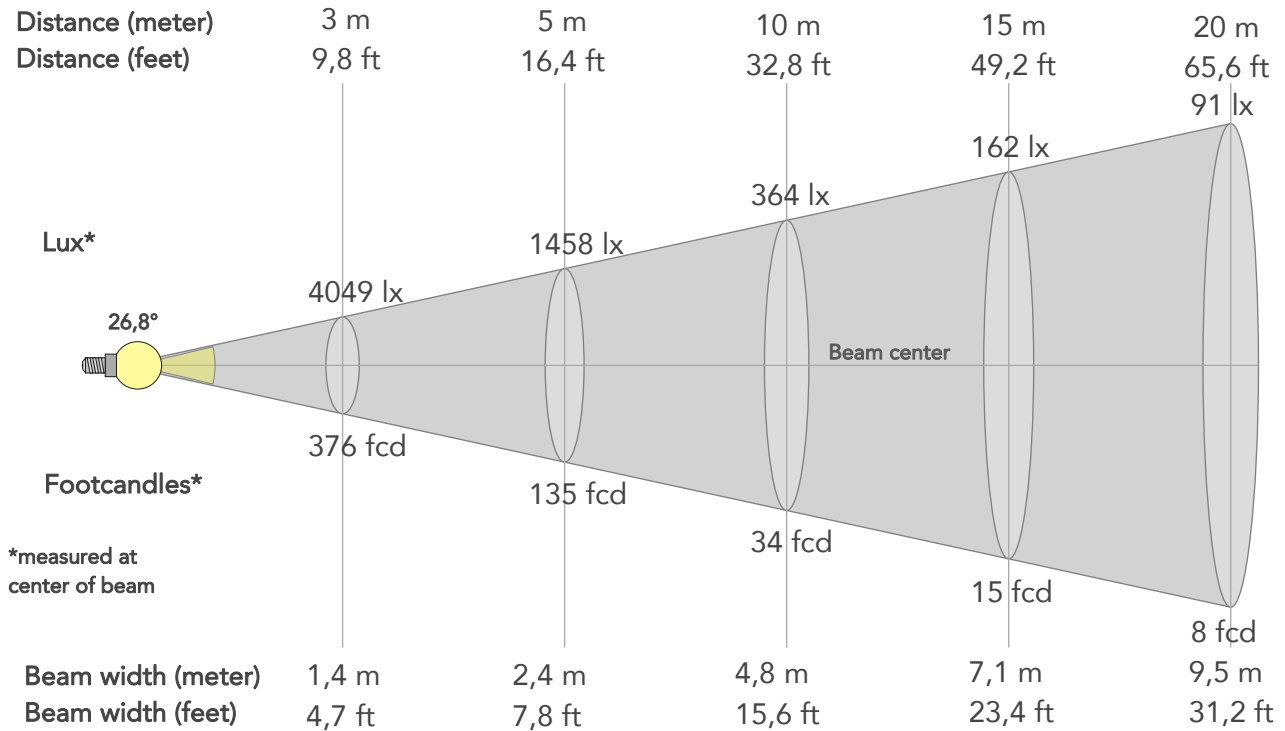

## BEAM INTENSITIES AND WIDTHS

Distance	1m	2m	3m	4m	5m	7,5m	10m	15m	20m	25m	30m	40m	50m
Distance	3,3ft	6,6ft	9,8ft	13,1ft	16,4ft	24,6ft	32,8ft	49,2ft	65,6ft	82ft	98,4ft	131,2ft	164ft
Lux	36441lx	9110lx	4049lx	2278lx	1458lx	648lx	364lx	162lx	91lx	58lx	40lx	23lx	15lx
Footcand.	3385fcd	846fcd	376fcd	212fcd	135fcd	60fcd	34fcd	15fcd	8fcd	5fcd	4fcd	2fcd	1fcd
Beam wid.	0,5m	1m	1,4m	1,9m	2,4m	3,6m	4,8m	7,1m	9,5m	11,9m	14,3m	19m	23,8m
Beam wid.	1,6ft	3,1ft	4,7ft	6,2ft	7,8ft	11,7ft	15,6ft	23,4ft	31,2ft	39ft	46,8ft	62,4ft	78ft

## LINEAR DISTRIBUTION DIAGRAM

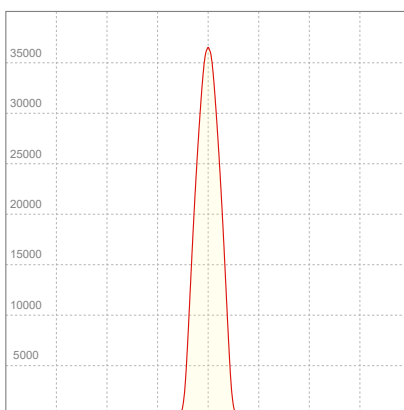

## ELECTRICAL SPECIFICATIONS

Input voltage	Input current	Input power	Effeciency
228V	1,35A	300,2W	23lm/W



## ISO CANDELA DIAGRAM

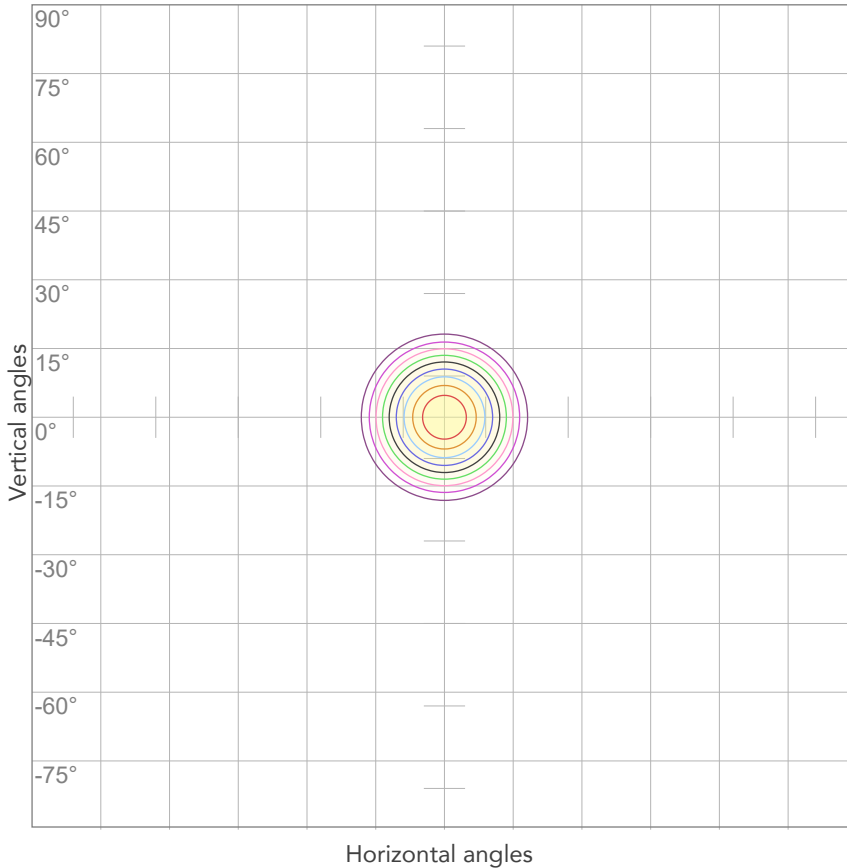

10%	3644 cd
20%	7288 cd
30%	10932 cd
40%	14576 cd
50%	18221 cd
60%	21865 cd
70%	25509 cd
80%	29153 cd

Conditions:

Number of c-planes: 2

Candela at center: 36441 cd

## ISO LUX DIAGRAM

MH: 10,0 m

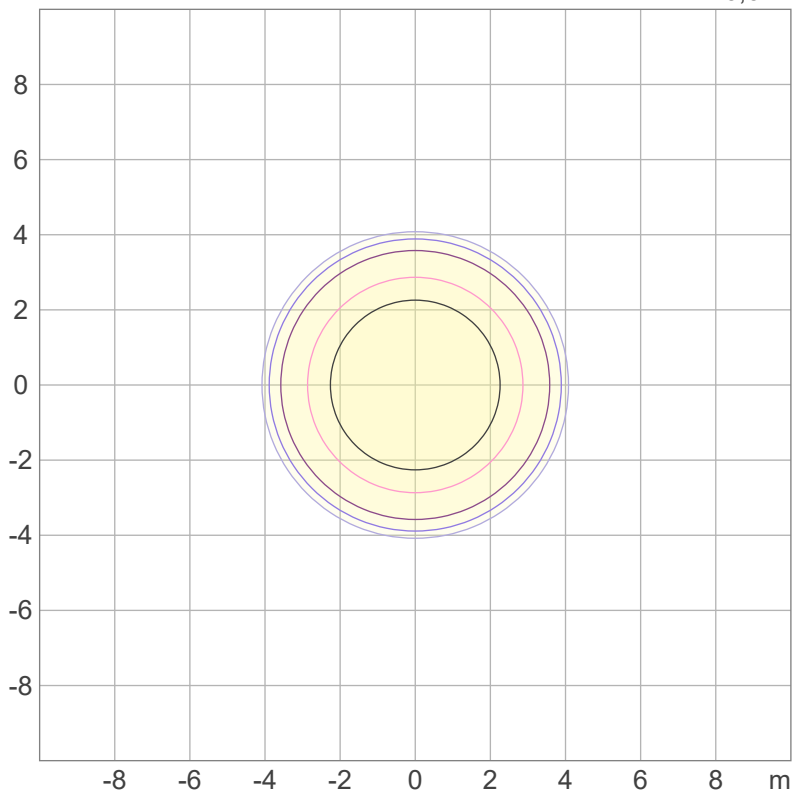

Mounting height: 10 meters (33 feet)

3%	10,9 lx
5%	18,2 lx
10%	36,4 lx
30%	109 lx
50%	182 lx

Conditions:

Number of c-planes: 2

Lux at center: 364 lx

*Lux distribution on a surface when lamp is mounted at 10 meters from the surface.*



Total lumen output:

3801 lm

Peak candela output:

134397 cd

Light quality:

CRI: 95,3

Color temperature:

5999 K

PRODUCT NAME:

ECLFRCTPM

MEASURAMENT CONDITIONS:

Beam angle:

Min Zoom

Target:

6000K - HB

Operator:

Salvatore Giglio

Date and time:

03/10/2023 11:22:47

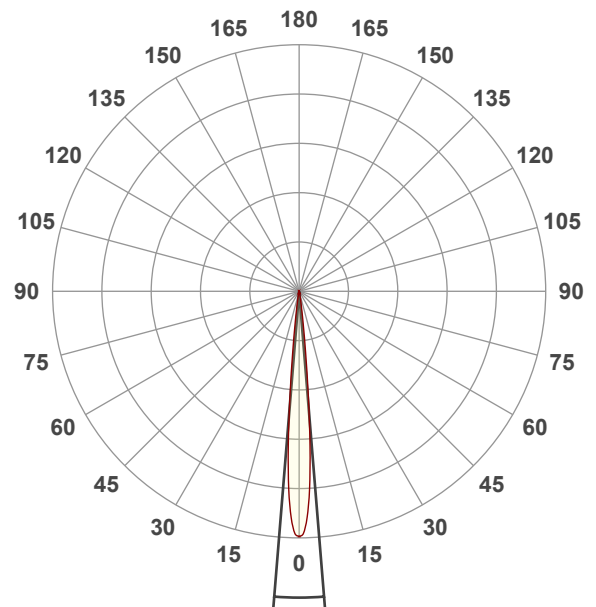

Beam angle 50%: 9,3°

Field angle 10%: 15,4°

Cut off angle 2.5%: 20,6°

Spectra

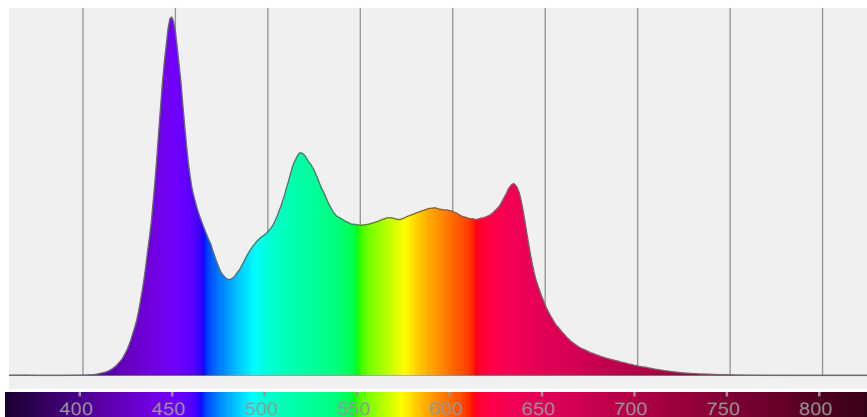

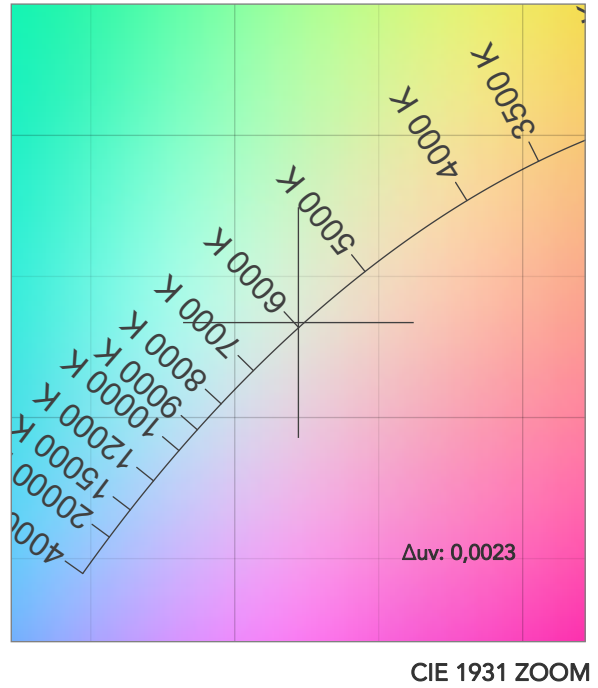
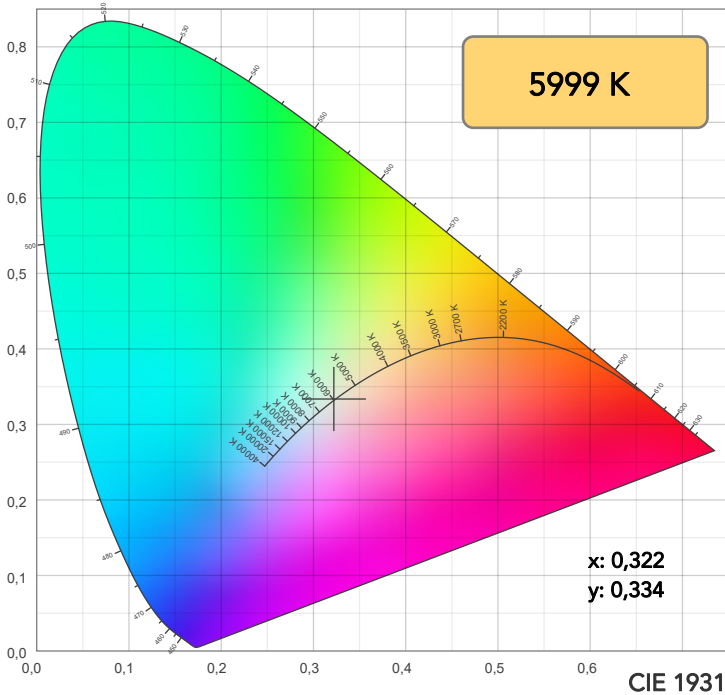

TM30: 92,6

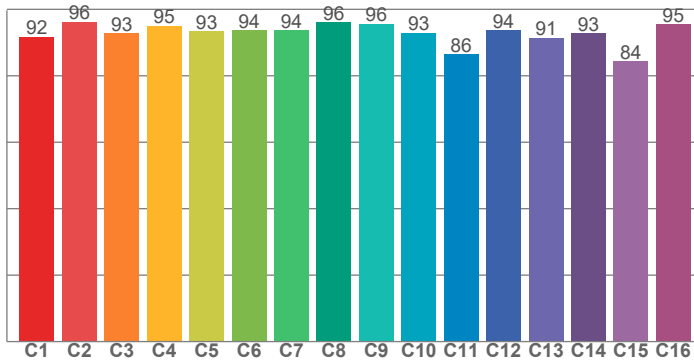

CRI: 95,3 (R1-R8)

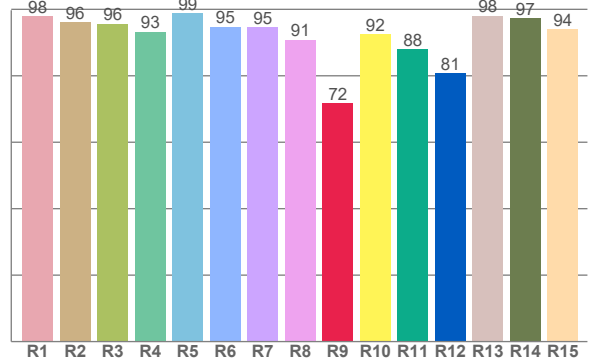

CRI R values, only R1-R8 are used to calculate final CRI value

R1	R2	R3	R4	R5	R6	R7	R8	R9	R10	R11	R12	R13	R14	R15
98,0	96,1	95,7	93,3	98,8	94,8	94,6	90,8	71,7	92,5	88,0	80,8	98,0	97,4	94,0

TM30 C values, 16 binned values out of total of 99 C values

C1	C2	C3	C4	C5	C6	C7	C8	C9	C10	C11	C12	C13	C14	C15	C16
91,8	96,2	92,8	95,0	93,4	93,7	93,7	96,1	95,6	93,0	86,5	93,6	91,4	92,7	84,3	95,4

CQS Q values

Q1	Q2	Q3	Q4	Q5	Q6	Q7	Q8	Q9	Q10	Q11	Q12	Q13	Q14	Q15
93,0	98,7	88,1	92,8	97,4	94,1	96,2	99,2	98,0	94,7	97,2	96,0	95,8	90,6	91,3

CQS: 94,0

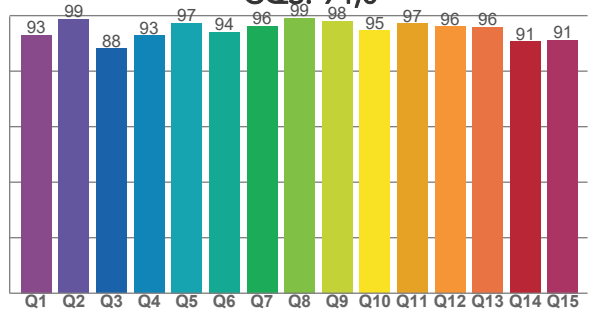

COLOR PARAMETERS

Color temperature	Color rendering index	Red component	Color fidelity	Color gamut	Color quality scale	Television lighting index	Color coordinate cie 1931	Color coordinate cie 1931	Color deviation from black body
CCT	CRI	CRI R9	TM30 Rf	TM30 Rg	CQS	TLCI	x	y	Δuv
5999 K	95,3	71,7	92,6	102,3	94,0	90	0,322	0,334	0,0023

# TM30 DETAILS

**Rf 92,6**  
Fidelity index Rf

**Rg 102,3**  
Gammut index

Hue Bin	R <sub>f</sub>	Graphic shifts (%)	
		Chroma	Hue
1	92	-4%	-1%
2	96	-1%	2%
3	93	-1%	4%
4	95	0%	2%
5	93	0%	2%
6	94	4%	2%
7	94	4%	1%
8	96	0%	0%
9	96	-1%	2%
10	93	-1%	4%
11	86	2%	8%
12	94	3%	1%
13	91	5%	-4%
14	93	4%	-2%
15	84	7%	-13%
16	95	0%	-2%

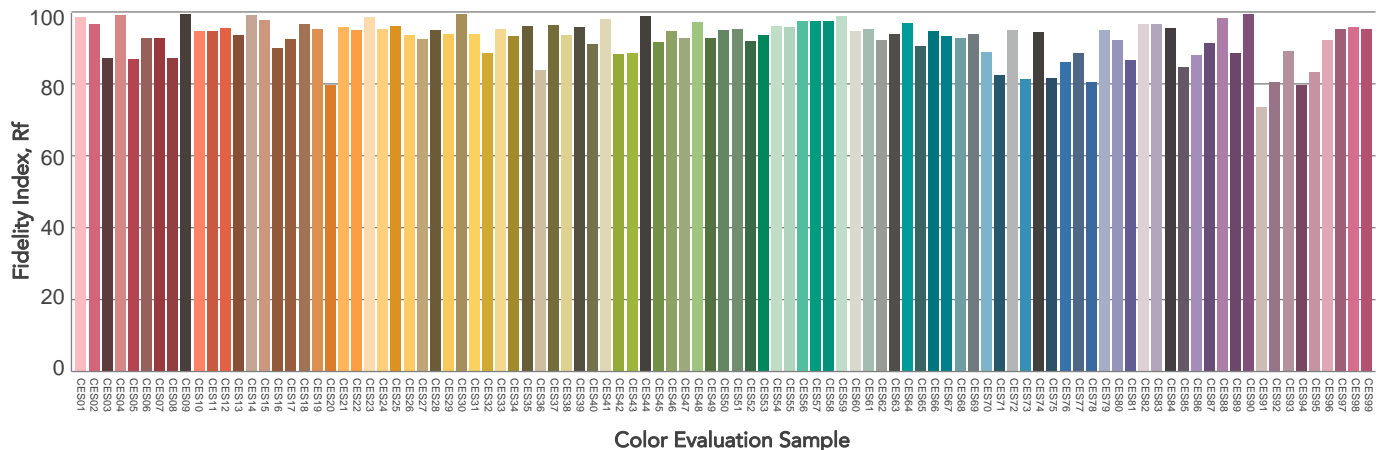
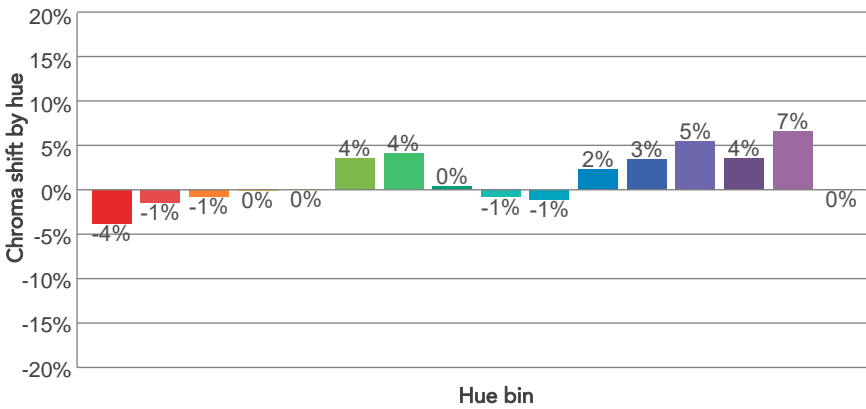
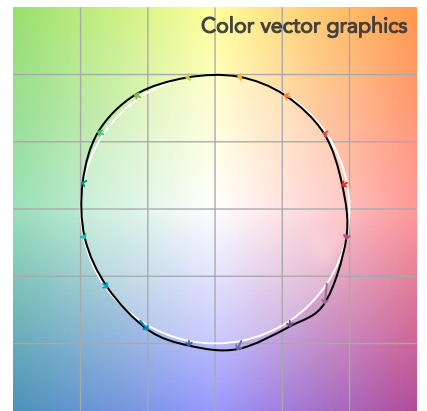
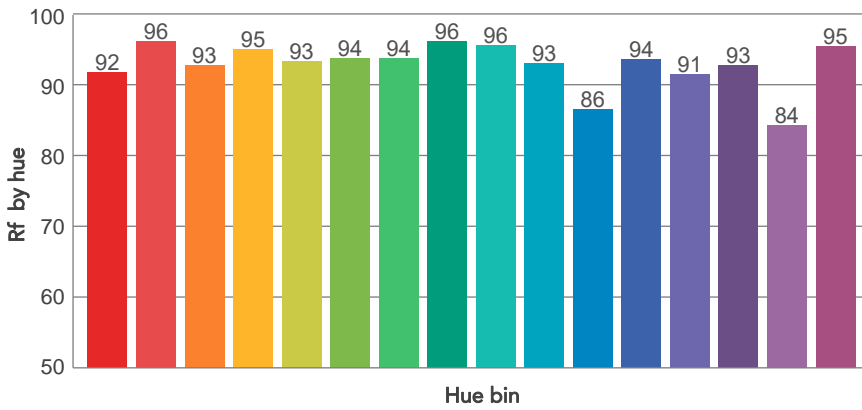
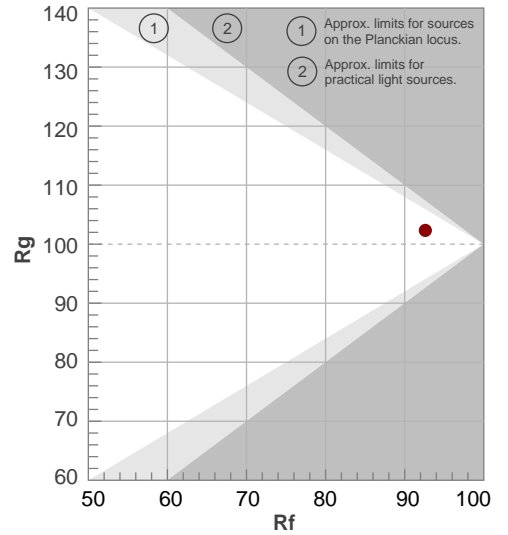

# BEAM DETAILS



Beam angle 50%	Field angle 10%	Cut off angle 2,5%	Intensity ratio in 120° cone	Intensity ratio in 90° cone
9,3°	15,4°	20,6°	100,0%	100,0%

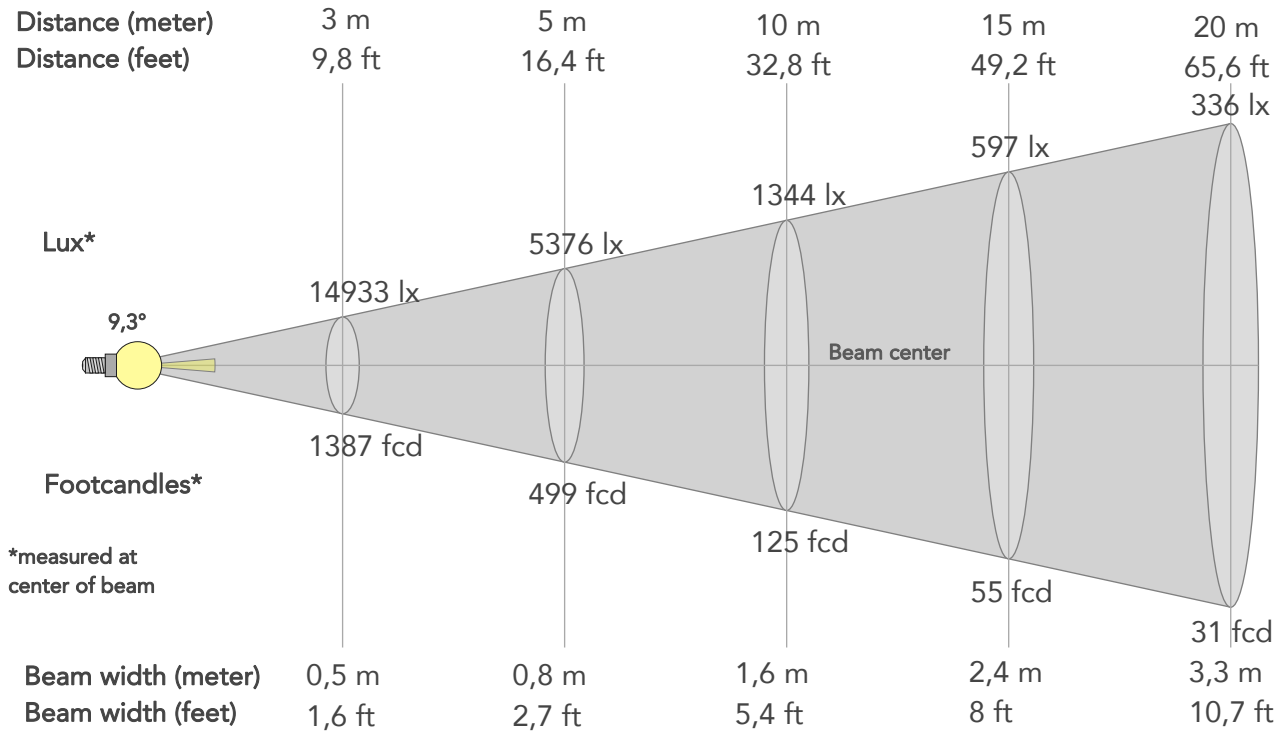

## BEAM INTENSITIES AND WIDTHS

Distance	1m	2m	3m	4m	5m	7,5m	10m	15m	20m	25m	30m	40m	50m
Distance	3,3ft	6,6ft	9,8ft	13,1ft	16,4ft	24,6ft	32,8ft	49,2ft	65,6ft	82ft	98,4ft	131,2ft	164ft
Lux	134397lx	33599lx	14933lx	8400lx	5376lx	2389lx	1344lx	597lx	336lx	215lx	149lx	84lx	54lx
Footcand.	12486fcd	3121fcd	1387fcd	780fcd	499fcd	222fcd	125fcd	55fcd	31fcd	20fcd	14fcd	8fcd	5fcd
Beam wid.	0,2m	0,3m	0,5m	0,7m	0,8m	1,2m	1,6m	2,4m	3,3m	4,1m	4,9m	6,5m	8,2m
Beam wid.	0,5ft	1,1ft	1,6ft	2,1ft	2,7ft	4ft	5,4ft	8ft	10,7ft	13,4ft	16,1ft	21,4ft	26,8ft

## LINEAR DISTRIBUTION DIAGRAM

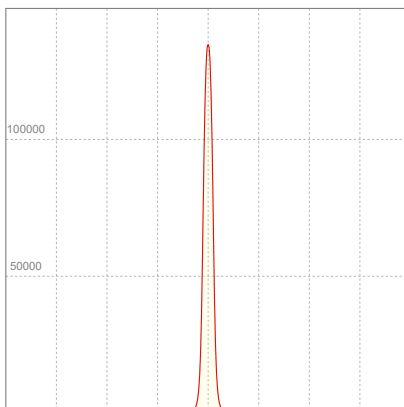

## ELECTRICAL SPECIFICATIONS

Input voltage	Input current	Input power	Effeciency
227V	1,34A	298,6W	13lm/W

## ISO CANDELA DIAGRAM

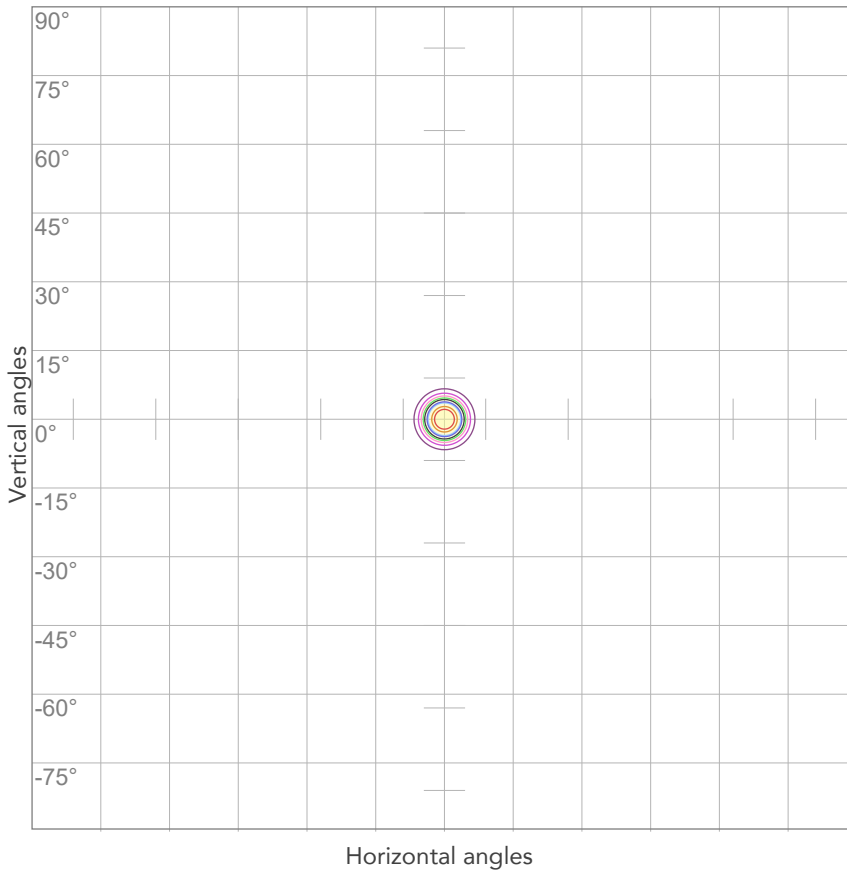

10%	13440 cd
20%	26879 cd
30%	40319 cd
40%	53759 cd
50%	67198 cd
60%	80638 cd
70%	94078 cd
80%	107517 cd

Conditions:

Number of c-planes: 2

Candela at center: 134397 cd

## ISO LUX DIAGRAM

MH: 10,0 m

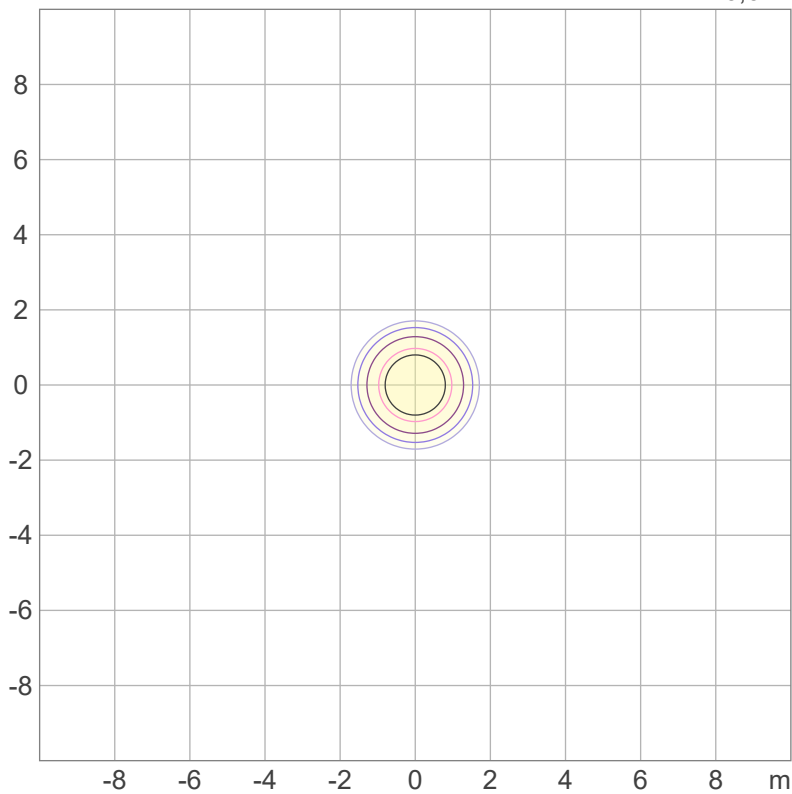

3%	40,3 lx
5%	67,2 lx
10%	134 lx
30%	403 lx
50%	672 lx

Conditions:

Number of c-planes: 2

Lux at center: 1344 lx

*Lux distribution on a surface when lamp is mounted at 10 meters from the surface.*