

# Photometric Test Report



## ECLFRESNELCT+S

200W indoor Led Fresnel with 6 color source  
150mm-6"lens  
(High Brightness Mode)

## CONTENTS

Table of contents	2
Testing process	4
Color preset Full on	
Max Zoom	5
Med Zoom	8
Min Zoom	11
Color preset Red	
Max Zoom	14
Med Zoom	17
Min Zoom	20
Color preset Green	
Max Zoom	23
Med Zoom	26
Min Zoom	29
Color preset Blue	
Max Zoom	32
Med Zoom	35
Min Zoom	38
Color preset Cyan	
Max Zoom	41
Med Zoom	44
Min Zoom	47
Color preset Mint	
Max Zoom	50
Med Zoom	53
Min Zoom	56
Color preset Amber	
Max Zoom	59
Med Zoom	62
Min Zoom	65

#### Color temperature 2800K

Max Zoom	68
Med Zoom	73
Min Zoom	78

#### Color temperature 3200K

Max Zoom	83
Med Zoom	88
Min Zoom	93

#### Color temperature 4000K

Max Zoom	98
Med Zoom	103
Min Zoom	108

#### Color temperature 5600K

Max Zoom	113
Med Zoom	118
Min Zoom	123

#### Color temperature 6000K

Max Zoom	128
Med Zoom	133
Min Zoom	138

## TESTING PROCESS

Prolights has its own optical testing laboratory in order to provide accurate photometric reports for its lighting products. The testing laboratory contains certain variety of precise lighting measurement systems that ensure an optimal reading of all the characteristic parameters of the lighting devices. All measurements are made at a controlled room temperature of 20°C without any external light sources. This photometric report is obtained through the data measured by a high precision measurement system and analyzed by a dedicate software.

### Prolights measurement instrument

Prolights measurement instrument is a complete measurement system for any light source. It's equipped with two-axis goniometer, that enables to measure the full 3D distribution field of the light source. This instrument measures the light intensity, the beam angle and the most significative colors parameters, like color temperature, spectral distribution, CRI, CQS, TM-30 with a very high accuracy rate.

**Please Note:** All measurements are made with light source at operating temperature. Before starting the measurement, the instrument analyzes the process of the light source during the heating phase. The measuring process of all the parameters begins only when the light emission is stable, that is with a variation of less than 0.5% in a 15 minutes time frame.

### Prolights measurement software

The software provides user friendly interface for the operator who does the measurements, and it also analyzes and processes all the collected data by the instrument. With this software it is possible to see the measured data in real-time and it is possible to examine all the measured data and graphics afterwards as well. All information is collected in a specific Prolights template, and the software creates also IES and LDT files, which are widely used to transfer the photometric data, and to develop lighting system.

Additionally, the fixtures are rechecked using various hand-held instruments like Sekonic C-700 and Gossen Mavospec Base, this is done to ensure, that the data in the photometric report are as accurate as possible.



Total lumen output:

4551 lm

Peak candela output:

6842 cd

PRODUCT NAME:

ECLFRCTPS

MEASUREMENT CONDITIONS:

Beam angle:

Max Zoom

Target:

Full On - HB

Operator:

Salvatore Giglio

Date and time:

18/09/2023 11:14:45

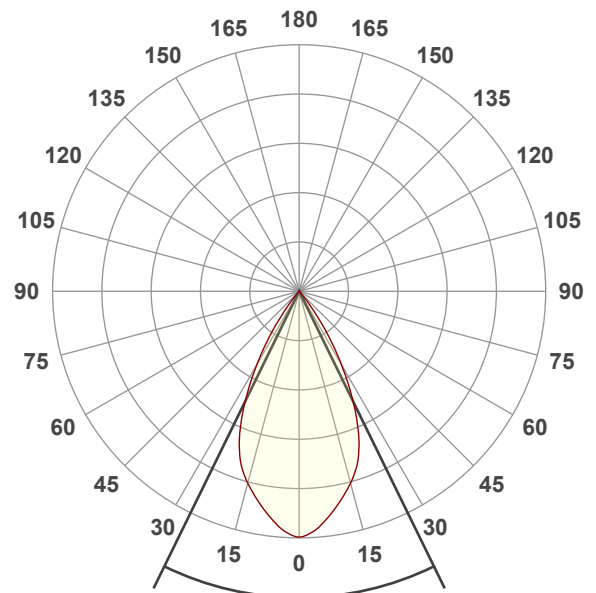

Beam angle 50%: 52,2°

Field angle 10%: 73,5°

Cut off angle 2.5%: 80,9°

Spectra

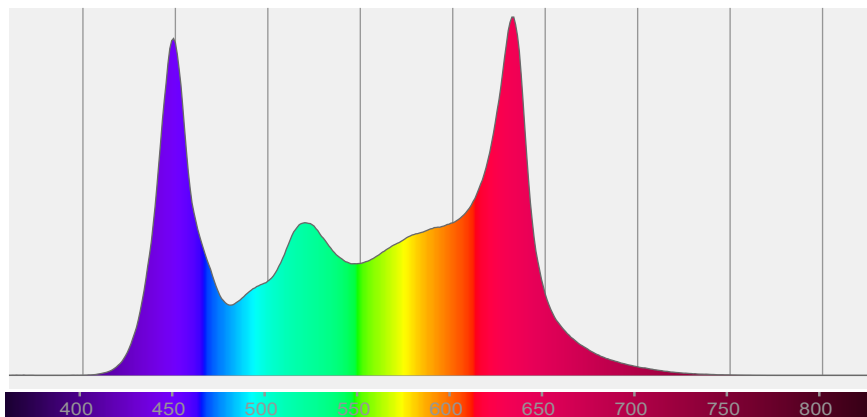

# BEAM DETAILS



Beam angle 50%	Field angle 10%	Cut off angle 2,5%	Intensity ratio in 120° cone	Intensity ratio in 90° cone
52,2°	73,5°	80,9°	100,0%	99,8%

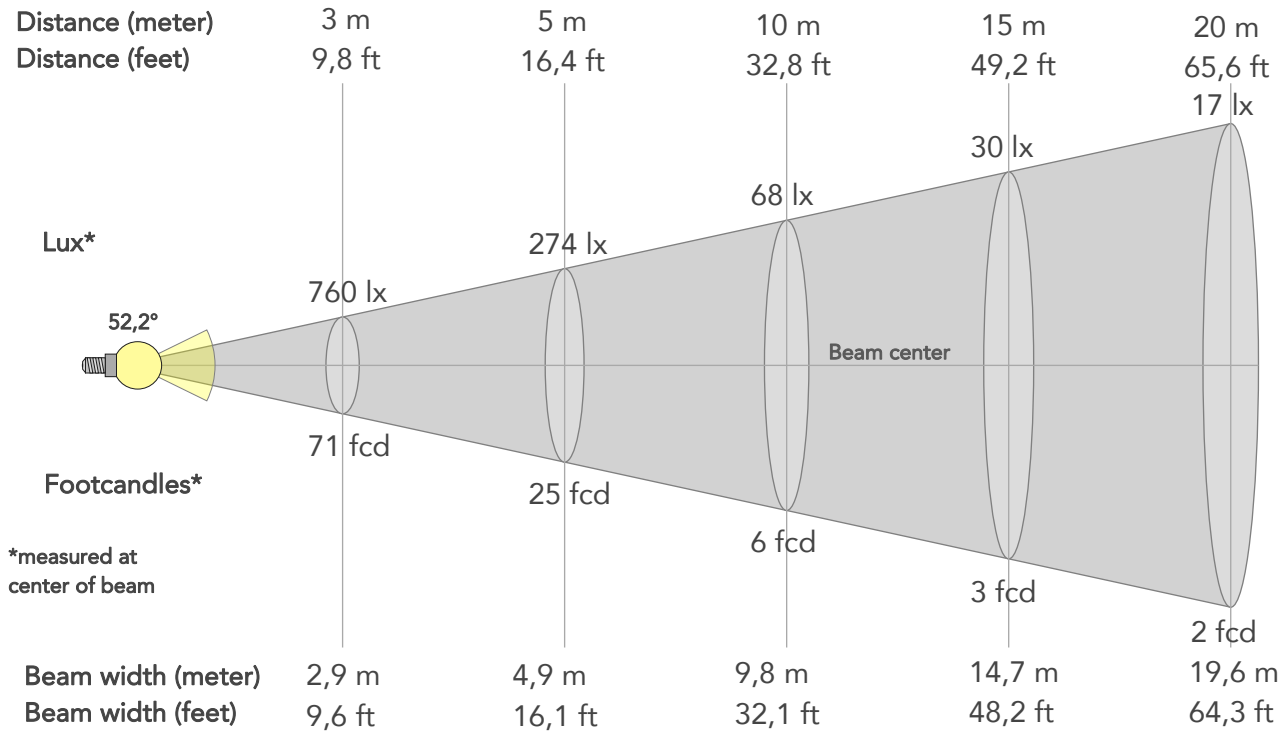

## BEAM INTENSITIES AND WIDTHS

Distance	1m	2m	3m	4m	5m	7,5m	10m	15m	20m	25m	30m	40m	50m
Distance	3,3ft	6,6ft	9,8ft	13,1ft	16,4ft	24,6ft	32,8ft	49,2ft	65,6ft	82ft	98,4ft	131,2ft	164ft
Lux	6842lx	1710lx	760lx	428lx	274lx	122lx	68lx	30lx	17lx	11lx	8lx	4lx	3lx
Footcand.	636fcd	159fcd	71fcd	40fcd	25fcd	11fcd	6fcd	3fcd	2fcd	1fcd	1fcd	0fcd	0fcd
Beam wid.	1m	2m	2,9m	3,9m	4,9m	7,4m	9,8m	14,7m	19,6m	24,5m	29,4m	39,2m	49m
Beam wid.	3,2ft	6,5ft	9,6ft	12,8ft	16,1ft	24,1ft	32,1ft	48,2ft	64,3ft	80,4ft	96,4ft	128,6ft	160,7ft

## LINEAR DISTRIBUTION DIAGRAM

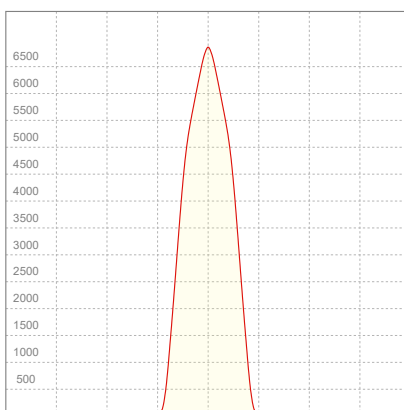

## ELECTRICAL SPECIFICATIONS

Input voltage	Input current	Input power	Effeciency
227V	0,872A	197,2W	23lm/W

Power FC
0,99

## ISO CANDELA DIAGRAM

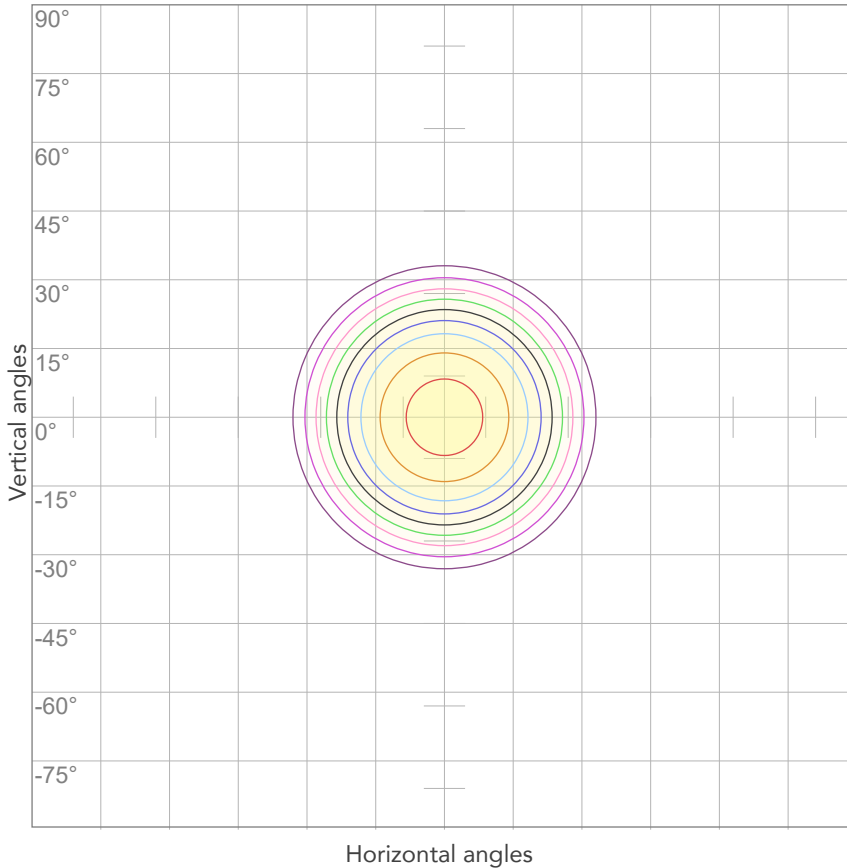

10%	684 cd
20%	1368 cd
30%	2052 cd
40%	2737 cd
50%	3421 cd
60%	4105 cd
70%	4789 cd
80%	5473 cd

Conditions:

Number of c-planes: 2

Candela at center: 6842 cd

## ISO LUX DIAGRAM

MH: 10,0 m

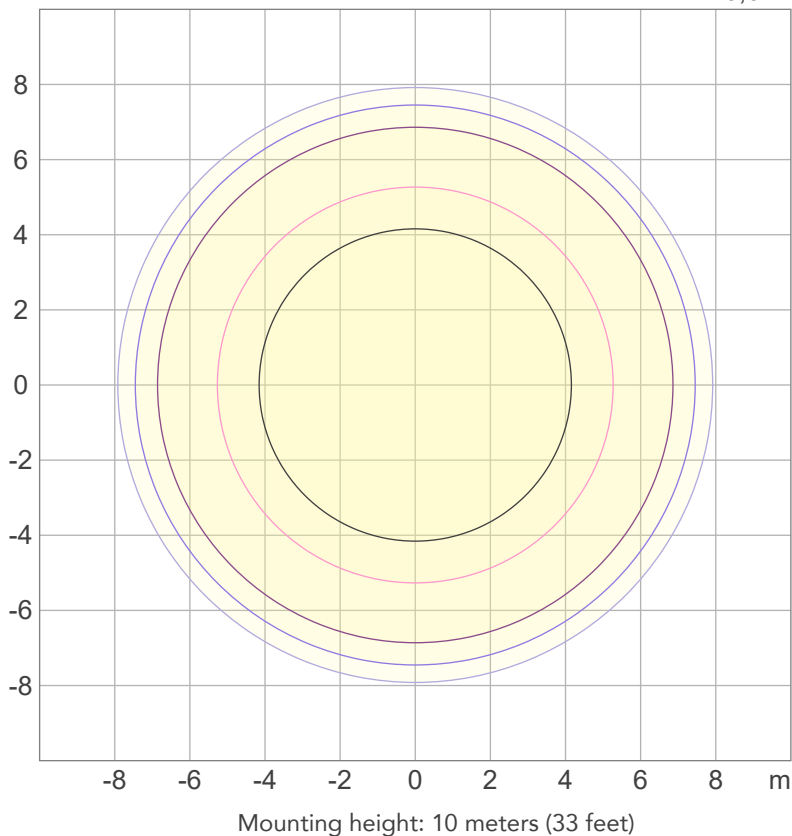

3%	2,05 lx
5%	3,42 lx
10%	6,84 lx
30%	20,5 lx
50%	34,2 lx

Conditions:

Number of c-planes: 2

Lux at center: 68,4 lx

*Lux distribution on a surface when lamp is mounted at 10 meters from the surface.*



Total lumen output:

3321 lm

Peak candela output:

23216 cd

PRODUCT NAME:

ECLFRCTPS

MEASURAMENT CONDITIONS:

Beam angle:

Med Zoom

Target:

Full On - HB

Operator:

Salvatore Giglio

Date and time:

18/09/2023 11:25:57

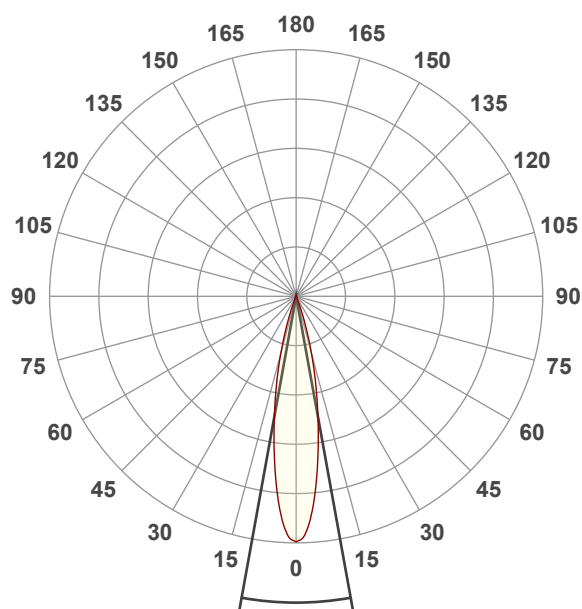

Beam angle 50%: 20,5°

Field angle 10%: 37°

Cut off angle 2.5%: 44,7°

Spectra

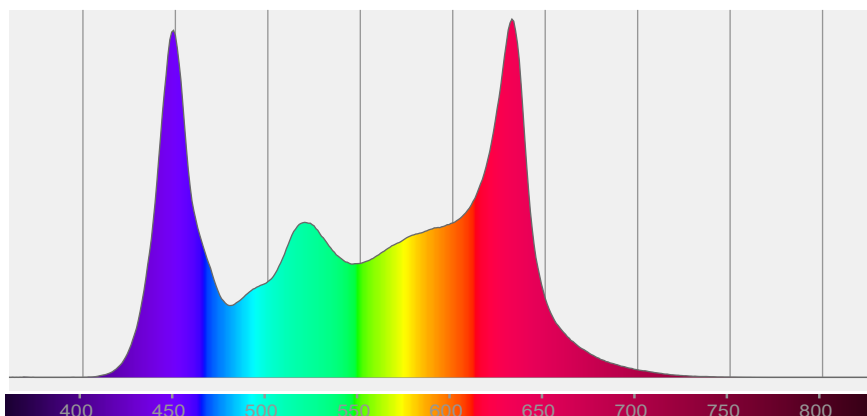



# BEAM DETAILS



Beam angle 50%	Field angle 10%	Cut off angle 2,5%	Intensity ratio in 120° cone	Intensity ratio in 90° cone
20,5°	37°	44,7°	100,0%	100,0%

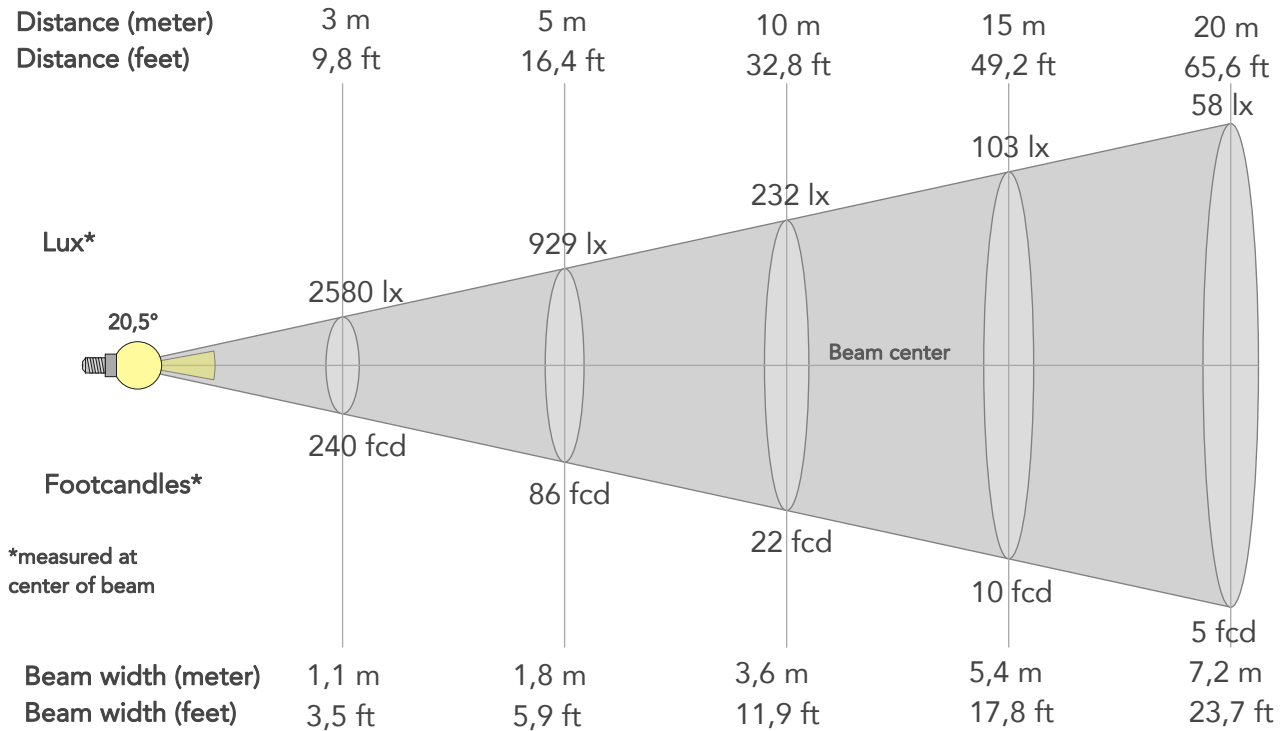

## BEAM INTENSITIES AND WIDTHS

Distance	1m	2m	3m	4m	5m	7,5m	10m	15m	20m	25m	30m	40m	50m
Distance	3,3ft	6,6ft	9,8ft	13,1ft	16,4ft	24,6ft	32,8ft	49,2ft	65,6ft	82ft	98,4ft	131,2ft	164ft
Lux	23216lx	5804lx	2580lx	1451lx	929lx	413lx	232lx	103lx	58lx	37lx	26lx	15lx	9lx
Footcand.	2157fcd	539fcd	240fcd	135fcd	86fcd	38fcd	22fcd	10fcd	5fcd	3fcd	2fcd	1fcd	1fcd
Beam wid.	0,4m	0,7m	1,1m	1,4m	1,8m	2,7m	3,6m	5,4m	7,2m	9m	10,9m	14,5m	18,1m
Beam wid.	1,2ft	2,4ft	3,5ft	4,7ft	5,9ft	8,9ft	11,9ft	17,8ft	23,7ft	29,7ft	35,6ft	47,5ft	59,3ft

## LINEAR DISTRIBUTION DIAGRAM

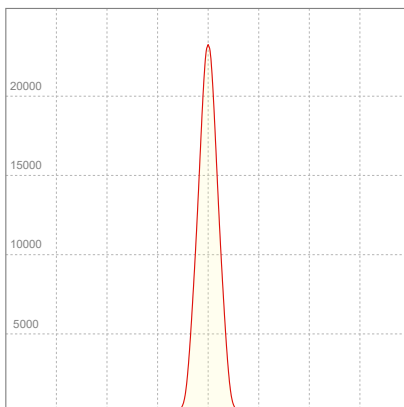

## ELECTRICAL SPECIFICATIONS

Input voltage	Input current	Input power	Effeciency
227V	0,878A	198W	17lm/W

Power FC
0,99

## ISO CANDELA DIAGRAM

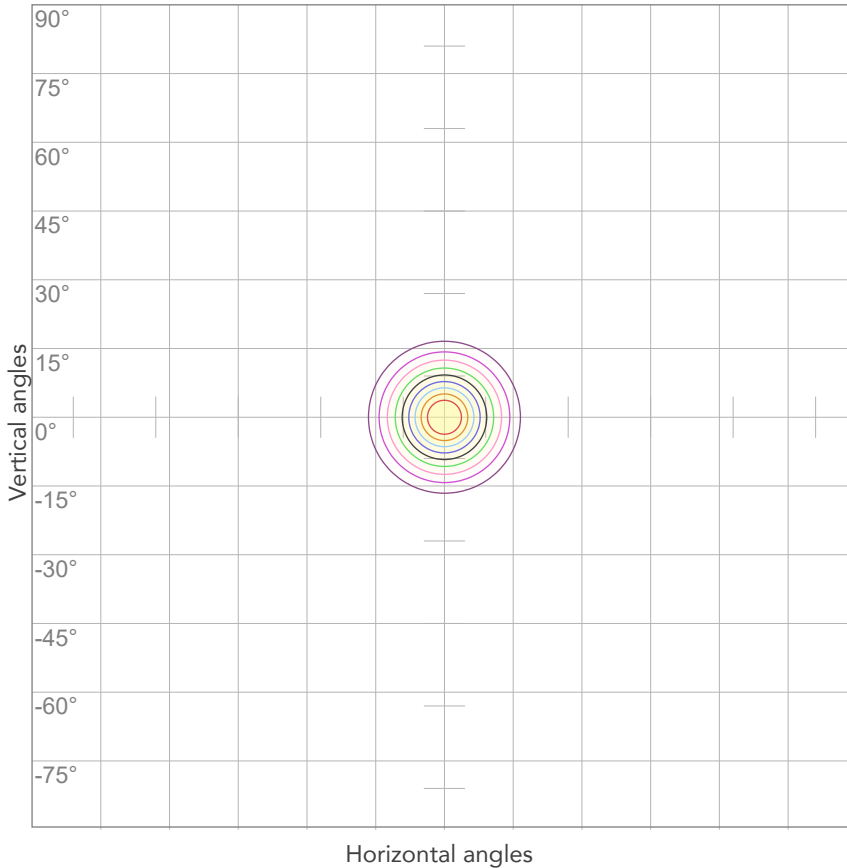

10%	2322 cd
20%	4643 cd
30%	6965 cd
40%	9286 cd
50%	11608 cd
60%	13929 cd
70%	16251 cd
80%	18573 cd

Conditions:

Number of c-planes: 2

Candela at center: 23216 cd

## ISO LUX DIAGRAM

MH: 10,0 m

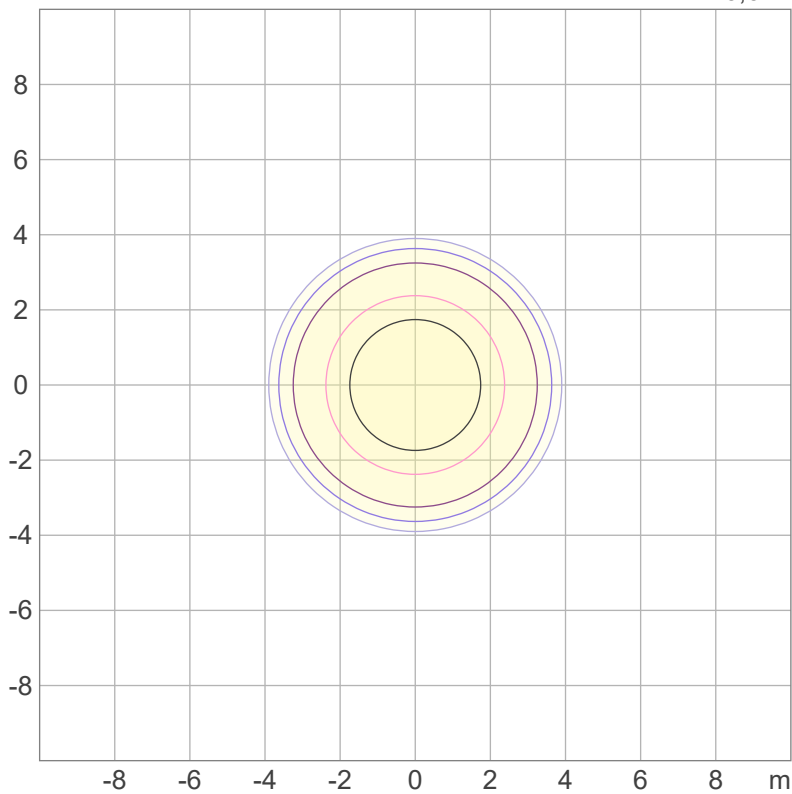

Mounting height: 10 meters (33 feet)

3%	6,96 lx
5%	11,6 lx
10%	23,2 lx
30%	69,6 lx
50%	116 lx

Conditions:

Number of c-planes: 2

Lux at center: 232 lx

*Lux distribution on a surface when lamp is mounted at 10 meters from the surface.*



Total lumen output:

1635 lm

Peak candela output:

51058 cd

PRODUCT NAME:

ECLFRCTPS

MEASURAMENT CONDITIONS:

Beam angle:

Min Zoom

Target:

Full On - HB

Operator:

Salvatore Giglio

Date and time:

18/09/2023 10:37:26

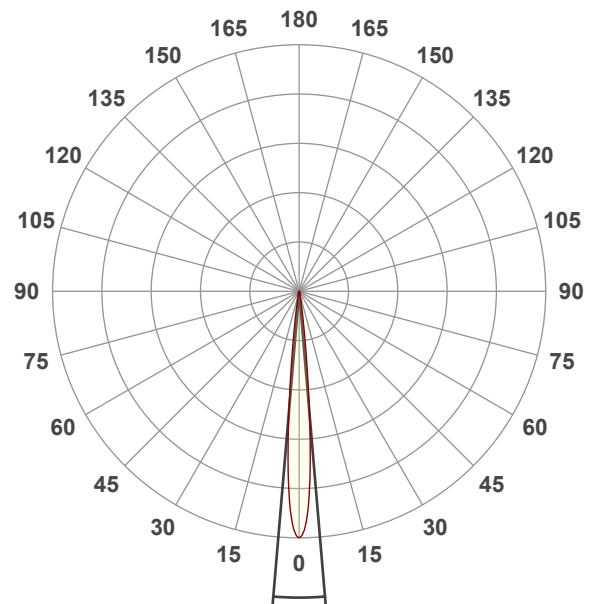

Beam angle 50%: 9,7°

Field angle 10%: 16,7°

Cut off angle 2.5%: 22,6°

Spectra

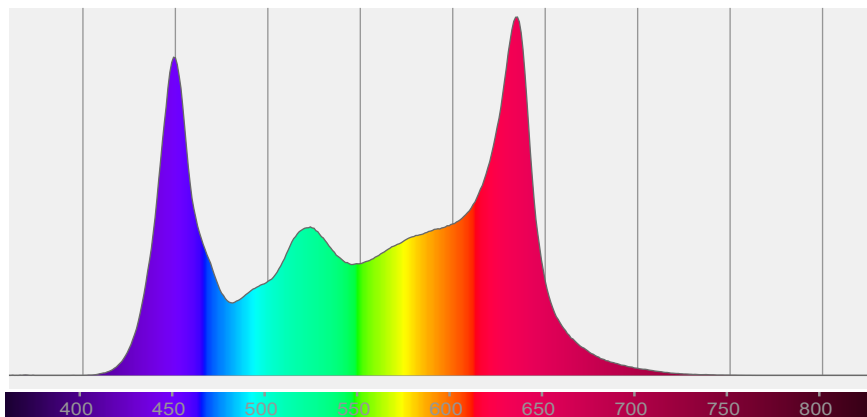

# BEAM DETAILS



Beam angle 50%	Field angle 10%	Cut off angle 2,5%	Intensity ratio in 120° cone	Intensity ratio in 90° cone
9,7°	16,7°	22,6°	100,0%	100,0%

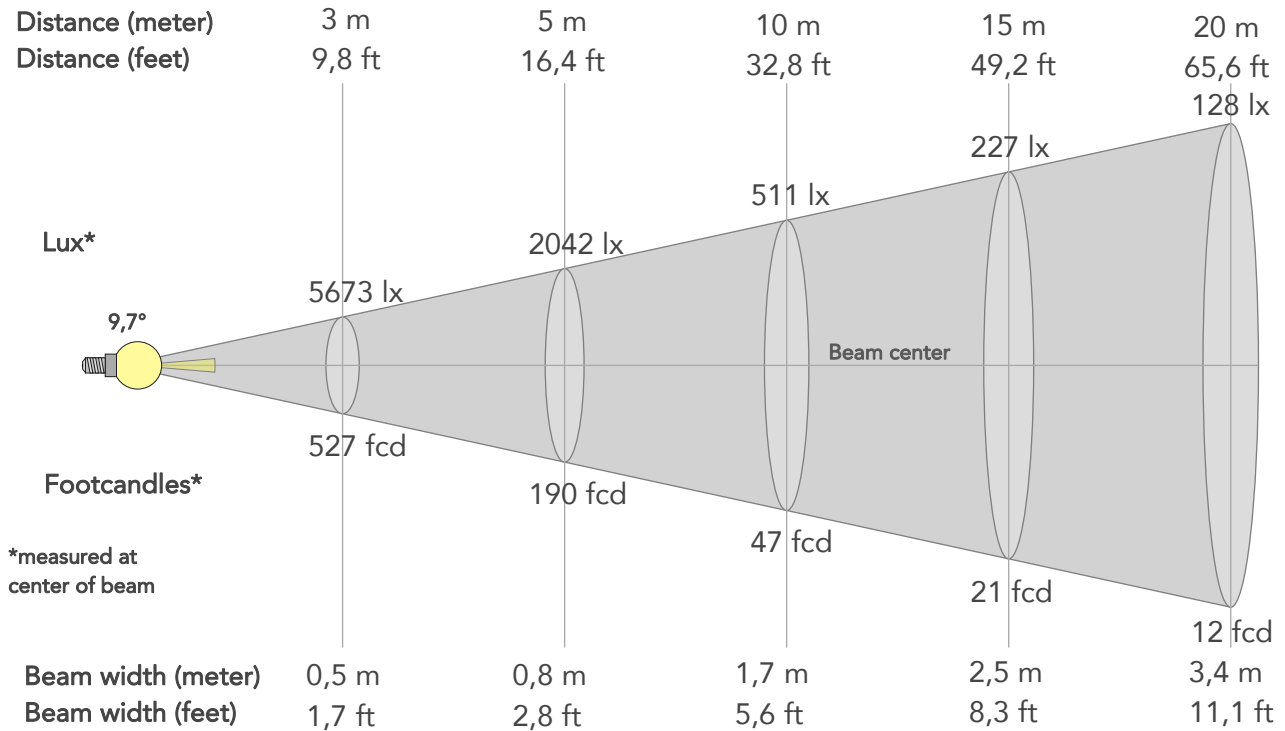

## BEAM INTENSITIES AND WIDTHS

Distance	1m	2m	3m	4m	5m	7,5m	10m	15m	20m	25m	30m	40m	50m
Distance	3,3ft	6,6ft	9,8ft	13,1ft	16,4ft	24,6ft	32,8ft	49,2ft	65,6ft	82ft	98,4ft	131,2ft	164ft
Lux	51058lx	12764lx	5673lx	3191lx	2042lx	908lx	511lx	227lx	128lx	82lx	57lx	32lx	20lx
Footcand.	4743fcd	1186fcd	527fcd	296fcd	190fcd	84fcd	47fcd	21fcd	12fcd	8fcd	5fcd	3fcd	2fcd
Beam wid.	0,2m	0,3m	0,5m	0,7m	0,8m	1,3m	1,7m	2,5m	3,4m	4,2m	5,1m	6,8m	8,5m
Beam wid.	0,6ft	1,1ft	1,7ft	2,2ft	2,8ft	4,2ft	5,6ft	8,3ft	11,1ft	13,9ft	16,7ft	22,2ft	27,8ft

## LINEAR DISTRIBUTION DIAGRAM

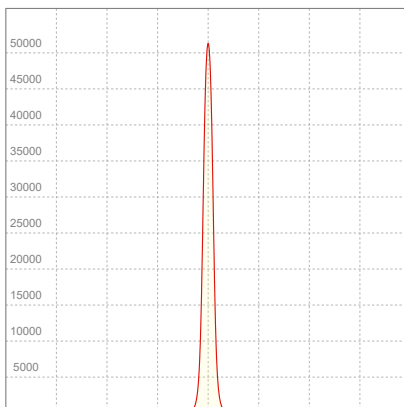

## ELECTRICAL SPECIFICATIONS

Input voltage	Input current	Input power	Effeciency
224V	0,867A	193,6W	8lm/W

Power FC
1,0

## ISO CANDELA DIAGRAM

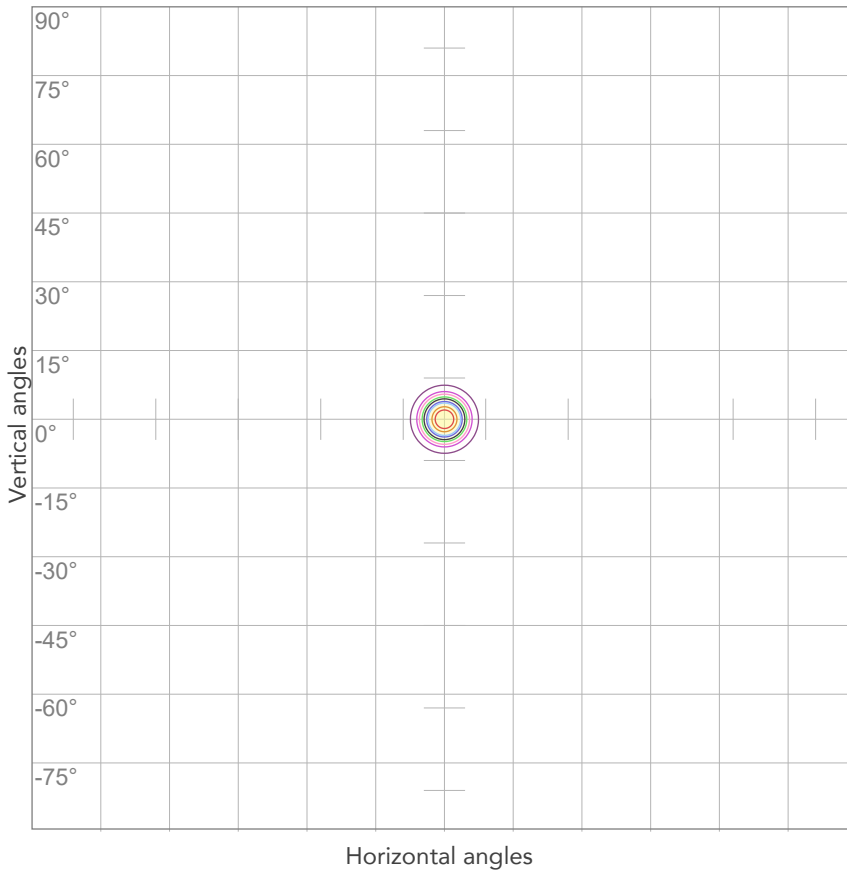

10%	5106 cd
20%	10212 cd
30%	15317 cd
40%	20423 cd
50%	25529 cd
60%	30635 cd
70%	35740 cd
80%	40846 cd

Conditions:

Number of c-planes: 2

Candela at center: 51058 cd

## ISO LUX DIAGRAM

MH: 10,0 m

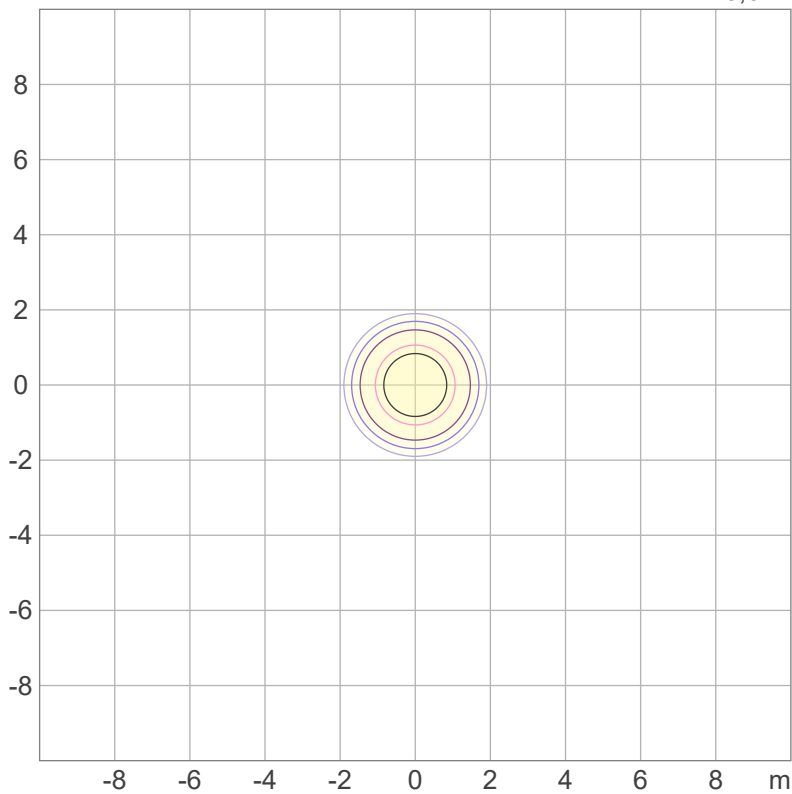

Mounting height: 10 meters (33 feet)

3%	15,3 lx
5%	25,5 lx
10%	51,1 lx
30%	153 lx
50%	255 lx

Conditions:

Number of c-planes: 2

Lux at center: 511 lx

*Lux distribution on a surface when lamp is mounted at 10 meters from the surface.*



Total lumen output:

754 lm

Peak candela output:

1110 cd

PRODUCT NAME:

ECLFRCTPS

MEASUREMENT CONDITIONS:

Beam angle:

Max Zoom

Target:

Red - HB

Operator:

Salvatore Giglio

Date and time:

02/10/2023 16:44:12

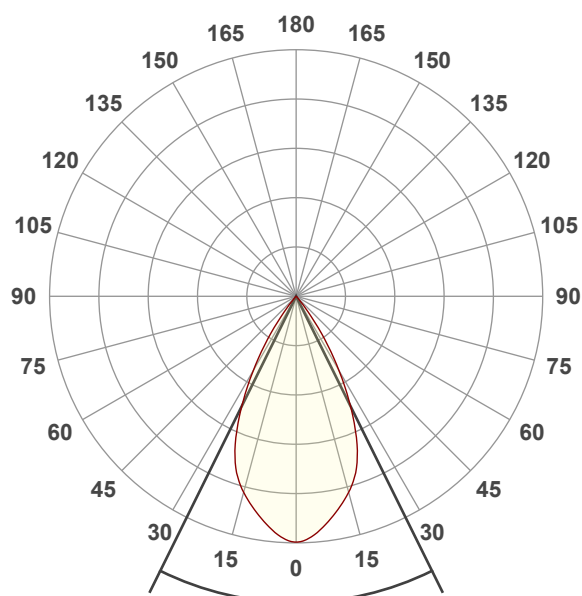

Beam angle 50%: 52,7°

Field angle 10%: 73,7°

Cut off angle 2.5%: 80,7°

Spectra

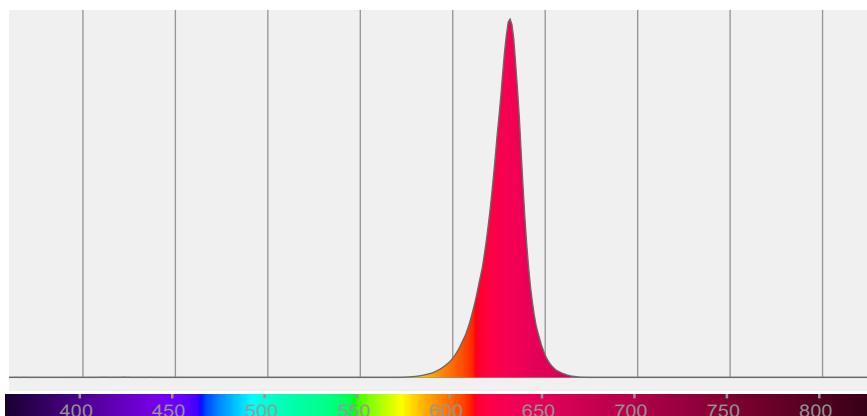

# BEAM DETAILS



Beam angle 50%	Field angle 10%	Cut off angle 2,5%	Intensity ratio in 120° cone	Intensity ratio in 90° cone
52,7°	73,7°	80,7°	100,0%	99,6%

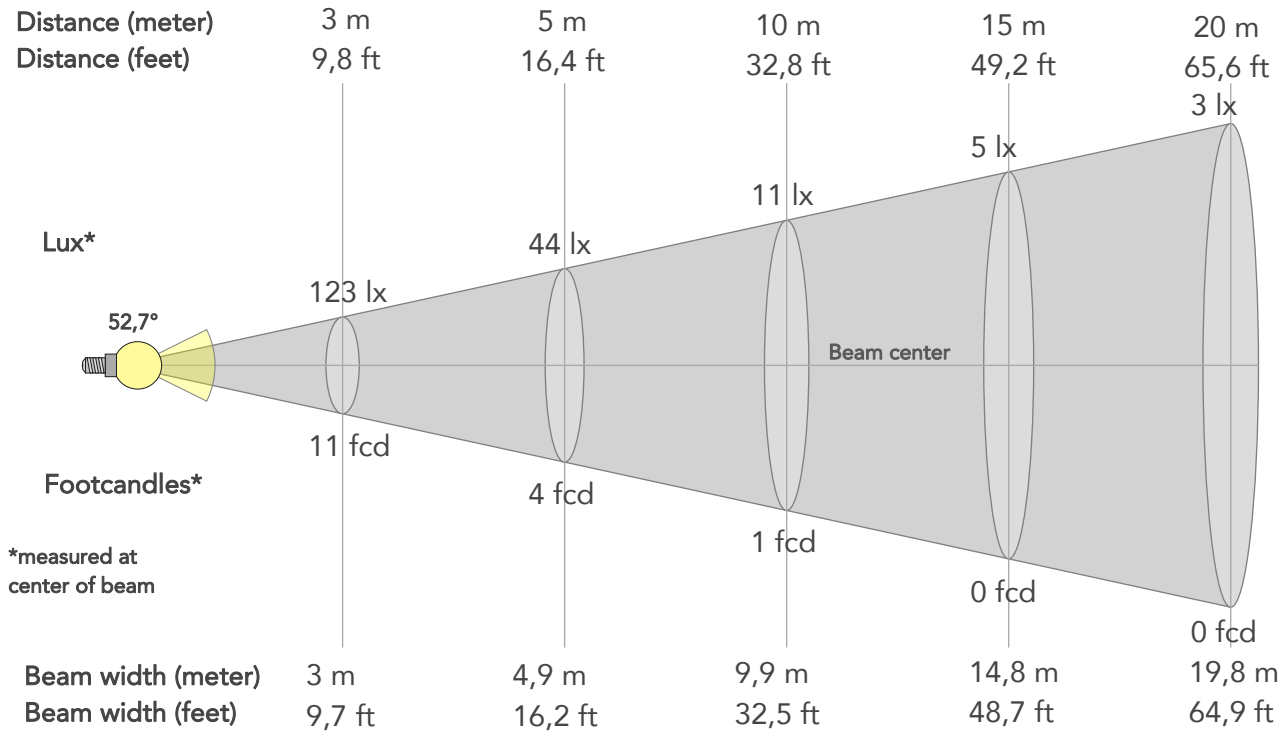

## BEAM INTENSITIES AND WIDTHS

Distance	1m	2m	3m	4m	5m	7,5m	10m	15m	20m	25m	30m	40m	50m
Distance	3,3ft	6,6ft	9,8ft	13,1ft	16,4ft	24,6ft	32,8ft	49,2ft	65,6ft	82ft	98,4ft	131,2ft	164ft
Lux	1110lx	277lx	123lx	69lx	44lx	20lx	11lx	5lx	3lx	2lx	1lx	1lx	0lx
Footcand.	103fcd	26fcd	11fcd	6fcd	4fcd	2fcd	1fcd	0fcd	0fcd	0fcd	0fcd	0fcd	0fcd
Beam wid.	1m	2m	3m	4m	4,9m	7,4m	9,9m	14,8m	19,8m	24,7m	29,7m	39,6m	49,5m
Beam wid.	3,3ft	6,5ft	9,7ft	13ft	16,2ft	24,3ft	32,5ft	48,7ft	64,9ft	81,2ft	97,4ft	129,9ft	162,3ft

## LINEAR DISTRIBUTION DIAGRAM

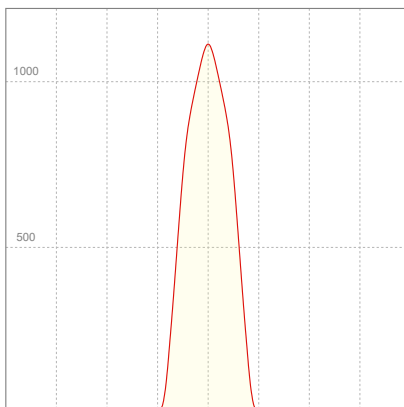

## ELECTRICAL SPECIFICATIONS

Input voltage	Input current	Input power	Effeciency
227V	0,210A	43,1W	18lm/W

Power FC
0,9

## ISO CANDELA DIAGRAM

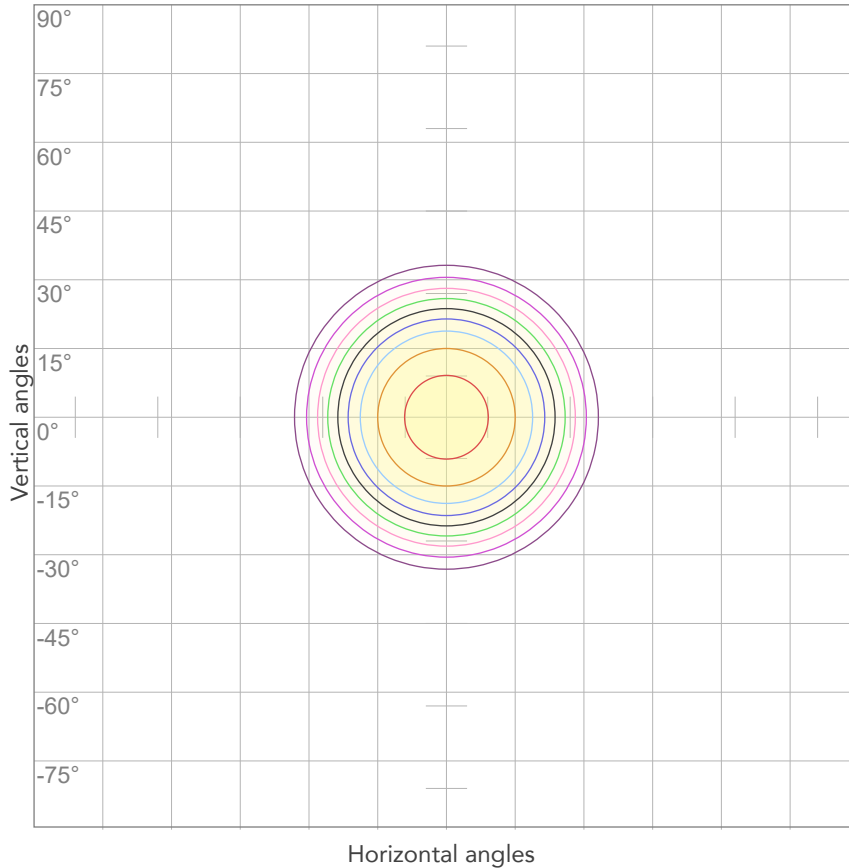

10%	111 cd
20%	222 cd
30%	333 cd
40%	444 cd
50%	555 cd
60%	666 cd
70%	777 cd
80%	888 cd

Conditions:

Number of c-planes: 2

Candela at center: 1110 cd

## ISO LUX DIAGRAM

MH: 10,0 m

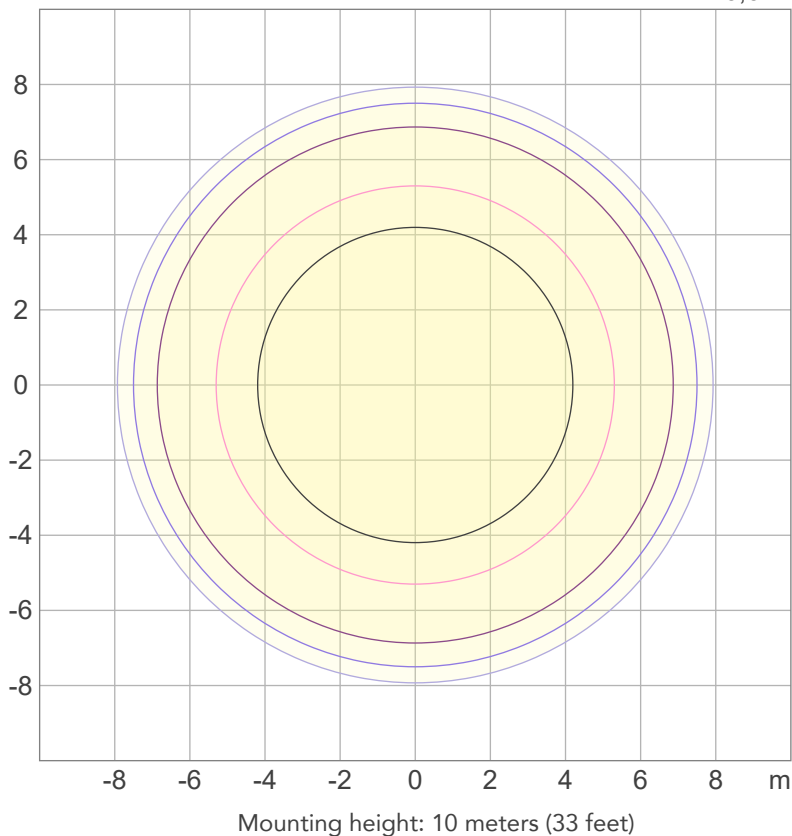

3%	0,333 lx
5%	0,555 lx
10%	1,11 lx
30%	3,33 lx
50%	5,55 lx

Conditions:

Number of c-planes: 2

Lux at center: 11,1 lx

*Lux distribution on a surface when lamp is mounted at 10 meters from the surface.*





Total lumen output:

557 lm

Peak candela output:

3742 cd

PRODUCT NAME:

ECLFRCTPS

MEASURAMENT CONDITIONS:

Beam angle:

Med Zoom

Target:

Red - HB

Operator:

Salvatore Giglio

Date and time:

02/10/2023 17:20:56

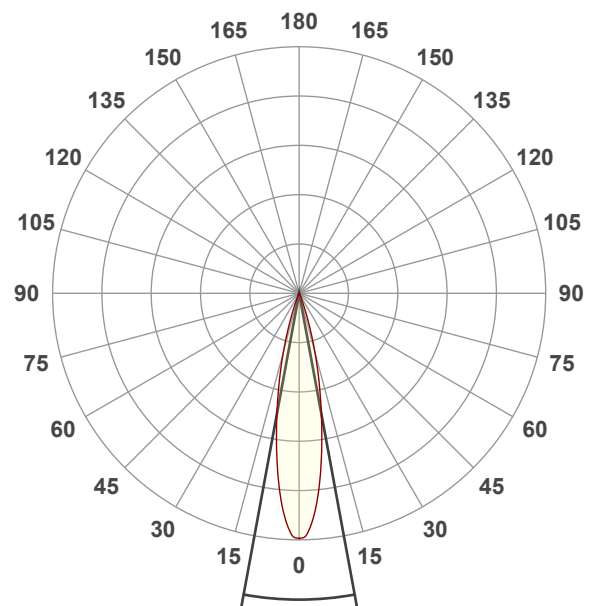

Beam angle 50%: 20,9°

Field angle 10%: 37,3°

Cut off angle 2.5%: 45,4°

Spectra

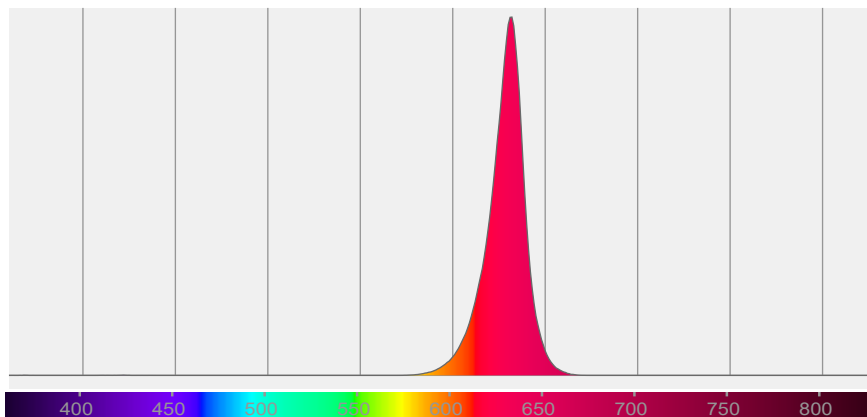

# BEAM DETAILS



Beam angle 50%	Field angle 10%	Cut off angle 2,5%	Intensity ratio in 120° cone	Intensity ratio in 90° cone
20,9°	37,3°	45,4°	100,0%	99,9%

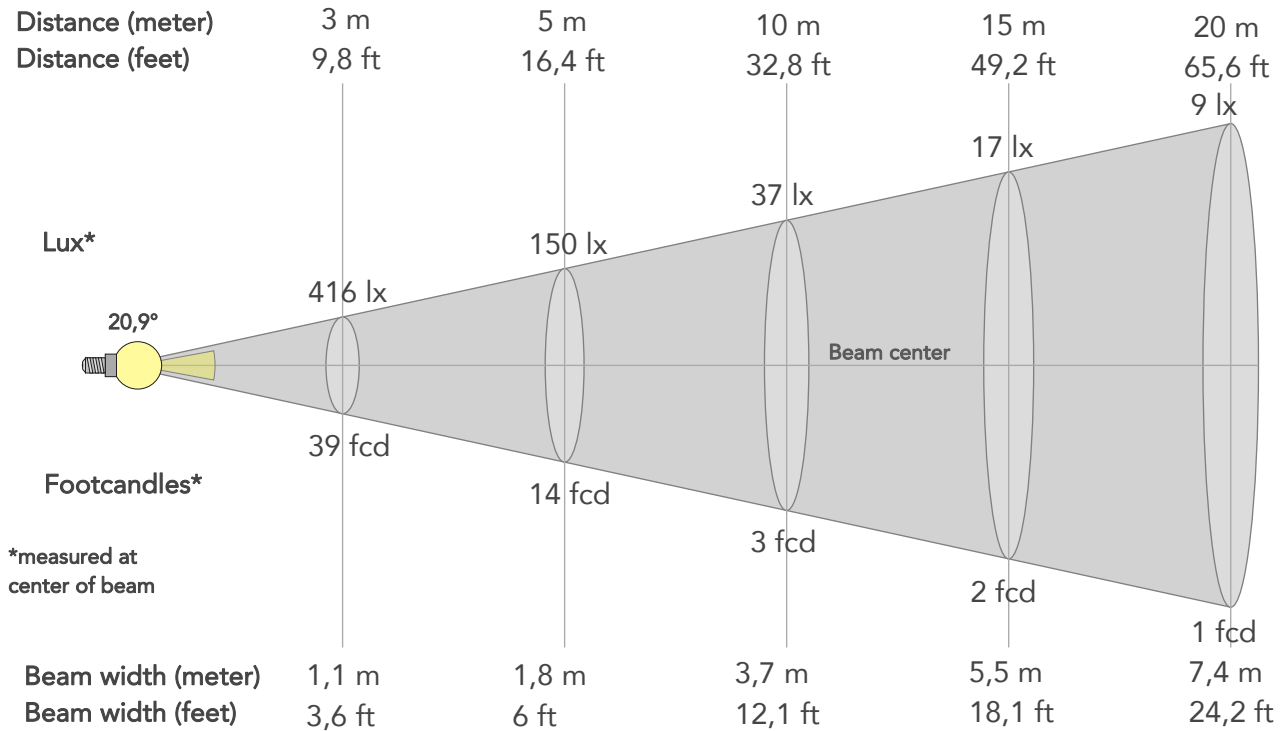

## BEAM INTENSITIES AND WIDTHS

Distance	1m	2m	3m	4m	5m	7,5m	10m	15m	20m	25m	30m	40m	50m
Distance	3,3ft	6,6ft	9,8ft	13,1ft	16,4ft	24,6ft	32,8ft	49,2ft	65,6ft	82ft	98,4ft	131,2ft	164ft
Lux	3742lx	936lx	416lx	234lx	150lx	67lx	37lx	17lx	9lx	6lx	4lx	2lx	1lx
Footcand.	348fcd	87fcd	39fcd	22fcd	14fcd	6fcd	3fcd	2fcd	1fcd	1fcd	0fcd	0fcd	0fcd
Beam wid.	0,4m	0,7m	1,1m	1,5m	1,8m	2,8m	3,7m	5,5m	7,4m	9,2m	11,1m	14,7m	18,4m
Beam wid.	1,2ft	2,4ft	3,6ft	4,8ft	6ft	9,1ft	12,1ft	18,1ft	24,2ft	30,2ft	36,3ft	48,4ft	60,5ft

## LINEAR DISTRIBUTION DIAGRAM

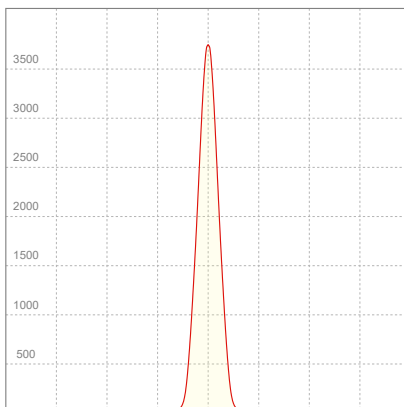

## ELECTRICAL SPECIFICATIONS

Input voltage	Input current	Input power	Effeciency
227V	0,220A	45,1W	12lm/W

Power FC
0,9

## ISO CANDELA DIAGRAM

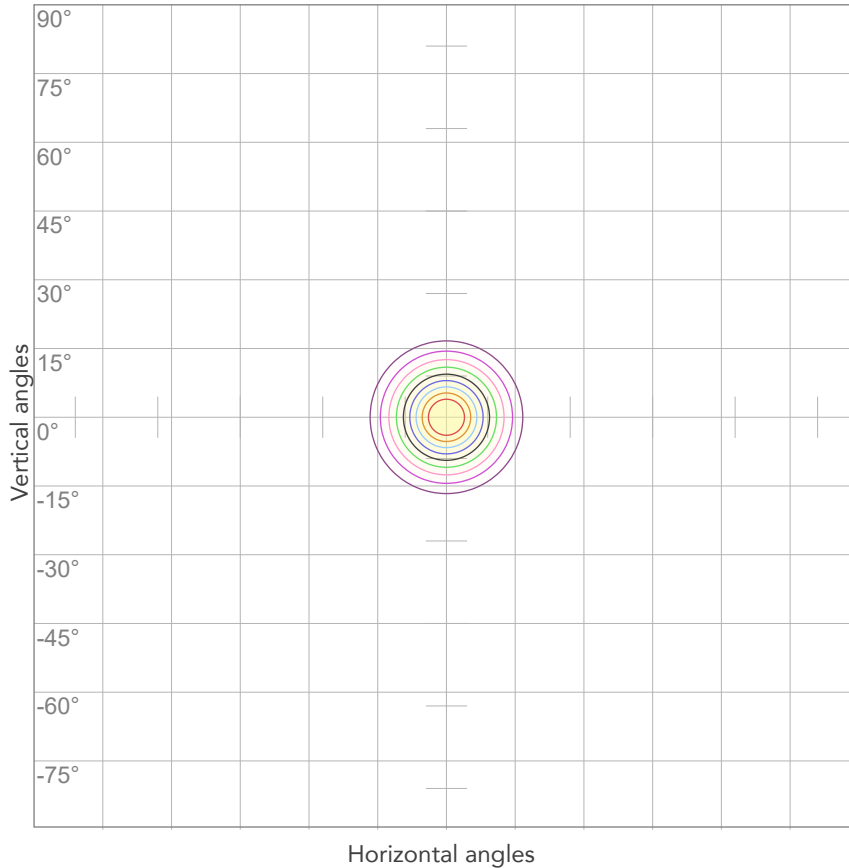

10%	374 cd
20%	748 cd
30%	1123 cd
40%	1497 cd
50%	1871 cd
60%	2245 cd
70%	2620 cd
80%	2994 cd

Conditions:

Number of c-planes: 2

Candela at center: 3742 cd

## ISO LUX DIAGRAM

MH: 10,0 m

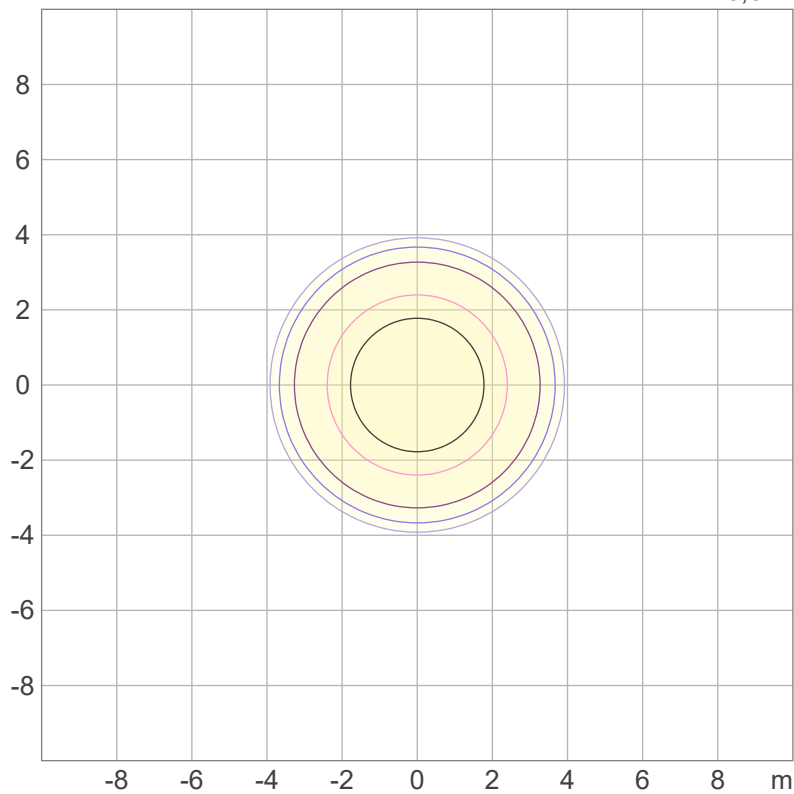

3%	1,12 lx
5%	1,87 lx
10%	3,74 lx
30%	11,2 lx
50%	18,7 lx

Conditions:

Number of c-planes: 2

Lux at center: 37,4 lx

*Lux distribution on a surface when lamp is mounted at 10 meters from the surface.*



Total lumen output:

308 lm

Peak candela output:

8752 cd

PRODUCT NAME:

ECLFRCTPS

MEASUREMENT CONDITIONS:

Beam angle:

Min Zoom

Target:

Red - HB

Operator:

Salvatore Giglio

Date and time:

02/10/2023 16:31:01

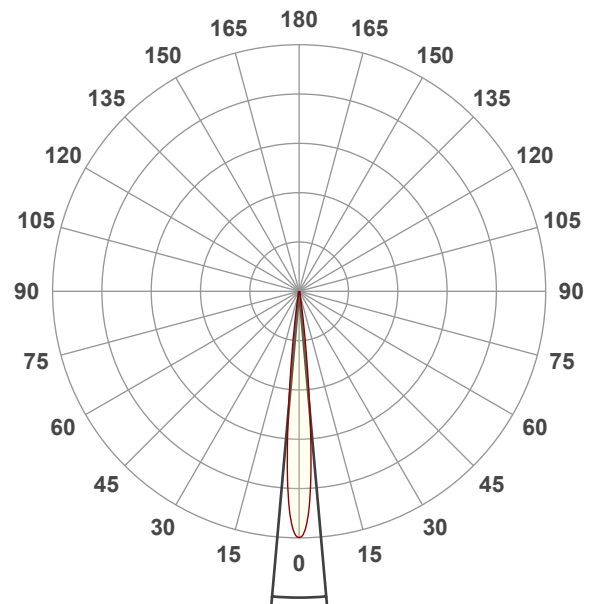

Spectra

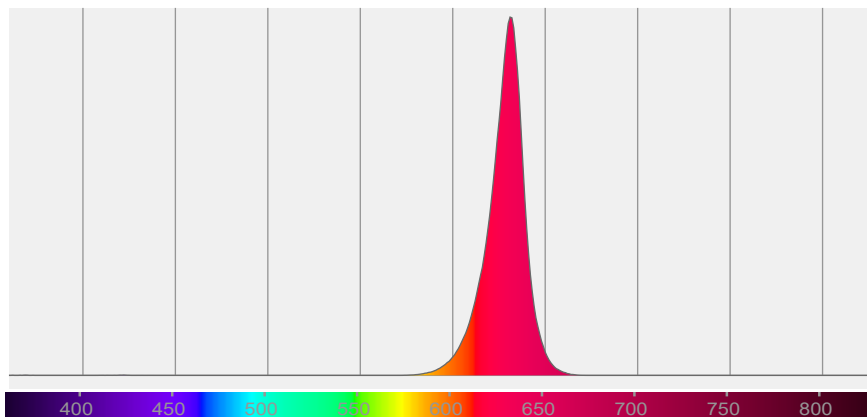

# BEAM DETAILS



Beam angle 50%	Field angle 10%	Cut off angle 2,5%	Intensity ratio in 120° cone	Intensity ratio in 90° cone
10,1°	16,9°	23°	100,0%	100,0%

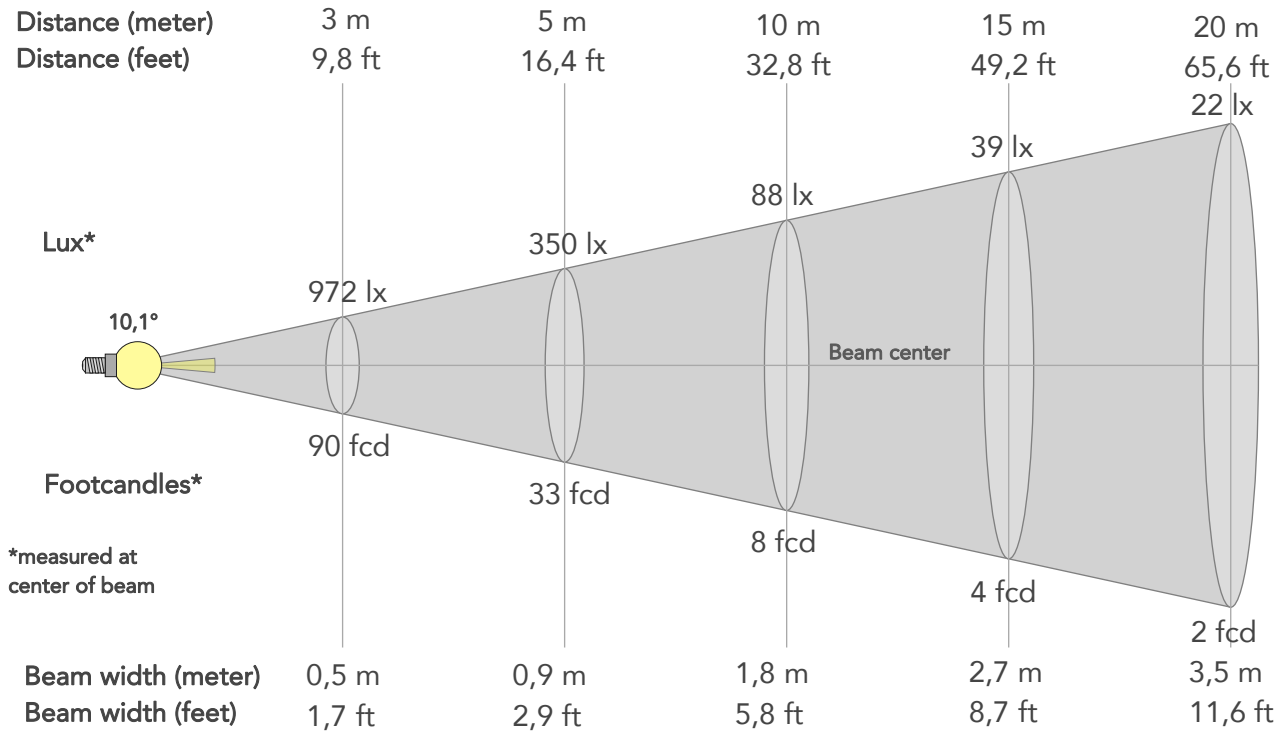

## BEAM INTENSITIES AND WIDTHS

Distance	1m	2m	3m	4m	5m	7,5m	10m	15m	20m	25m	30m	40m	50m
Distance	3,3ft	6,6ft	9,8ft	13,1ft	16,4ft	24,6ft	32,8ft	49,2ft	65,6ft	82ft	98,4ft	131,2ft	164ft
Lux	8752lx	2188lx	972lx	547lx	350lx	156lx	88lx	39lx	22lx	14lx	10lx	5lx	4lx
Footcand.	813fcd	203fcd	90fcd	51fcd	33fcd	14fcd	8fcd	4fcd	2fcd	1fcd	1fcd	1fcd	0fcd
Beam wid.	0,2m	0,4m	0,5m	0,7m	0,9m	1,3m	1,8m	2,7m	3,5m	4,4m	5,3m	7,1m	8,9m
Beam wid.	0,6ft	1,2ft	1,7ft	2,3ft	2,9ft	4,4ft	5,8ft	8,7ft	11,6ft	14,6ft	17,5ft	23,3ft	29,1ft

## LINEAR DISTRIBUTION DIAGRAM

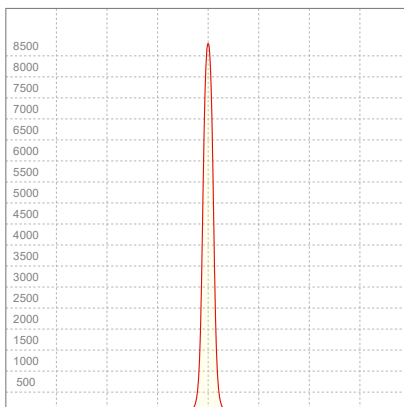

## ELECTRICAL SPECIFICATIONS

Input voltage	Input current	Input power	Effeciency
227V	0,219A	45,3W	7lm/W

Power FC
0,91

## ISO CANDELA DIAGRAM

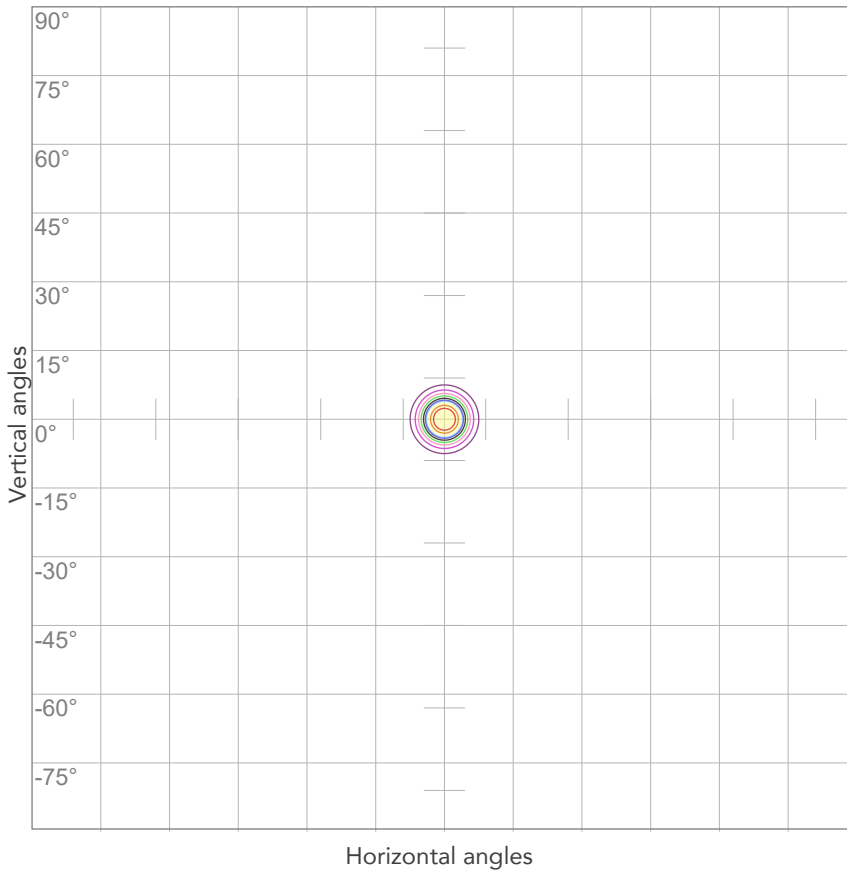

10%	875 cd
20%	1750 cd
30%	2626 cd
40%	3501 cd
50%	4376 cd
60%	5251 cd
70%	6126 cd
80%	7002 cd

Conditions:

Number of c-planes: 2

Candela at center: 8752 cd

## ISO LUX DIAGRAM

MH: 10,0 m

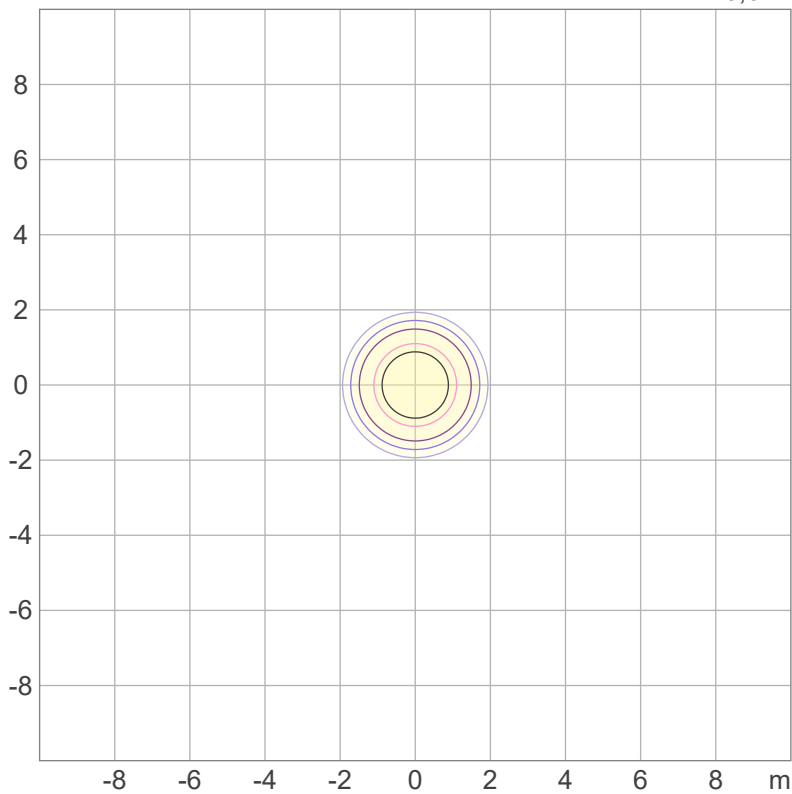

3%	2,63 lx
5%	4,38 lx
10%	8,75 lx
30%	26,3 lx
50%	43,8 lx

Conditions:

Number of c-planes: 2

Lux at center: 87,5 lx

*Lux distribution on a surface when lamp is mounted at 10 meters from the surface.*



Total lumen output:

1171 lm

Peak candela output:

1665 cd

PRODUCT NAME:

ECLFRCTPS

MEASURAMENT CONDITIONS:

Beam angle:

Max Zoom

Target:

Green - HB

Operator:

Salvatore Giglio

Date and time:

02/10/2023 16:45:37

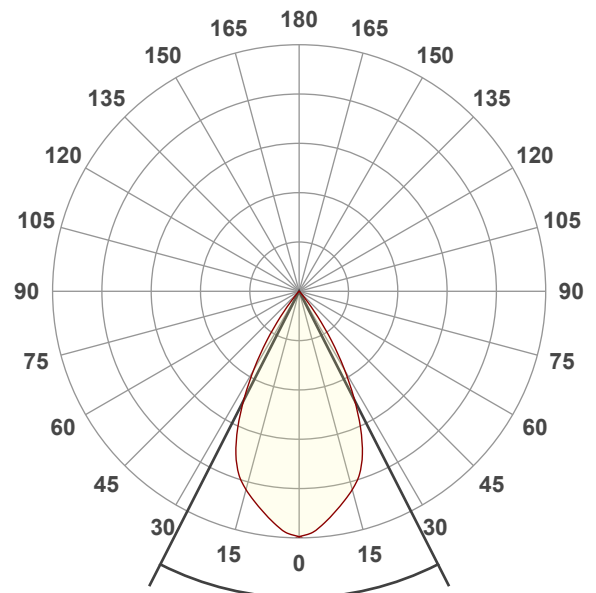

Beam angle 50%: 53,9°

Field angle 10%: 74,5°

Cut off angle 2.5%: 82,2°

Spectra

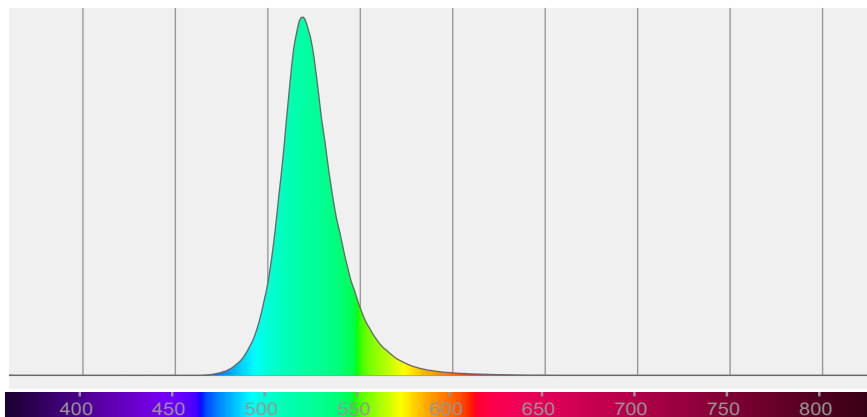

# BEAM DETAILS



Beam angle 50%	Field angle 10%	Cut off angle 2,5%	Intensity ratio in 120° cone	Intensity ratio in 90° cone
53,9°	74,5°	82,2°	100,0%	99,5%

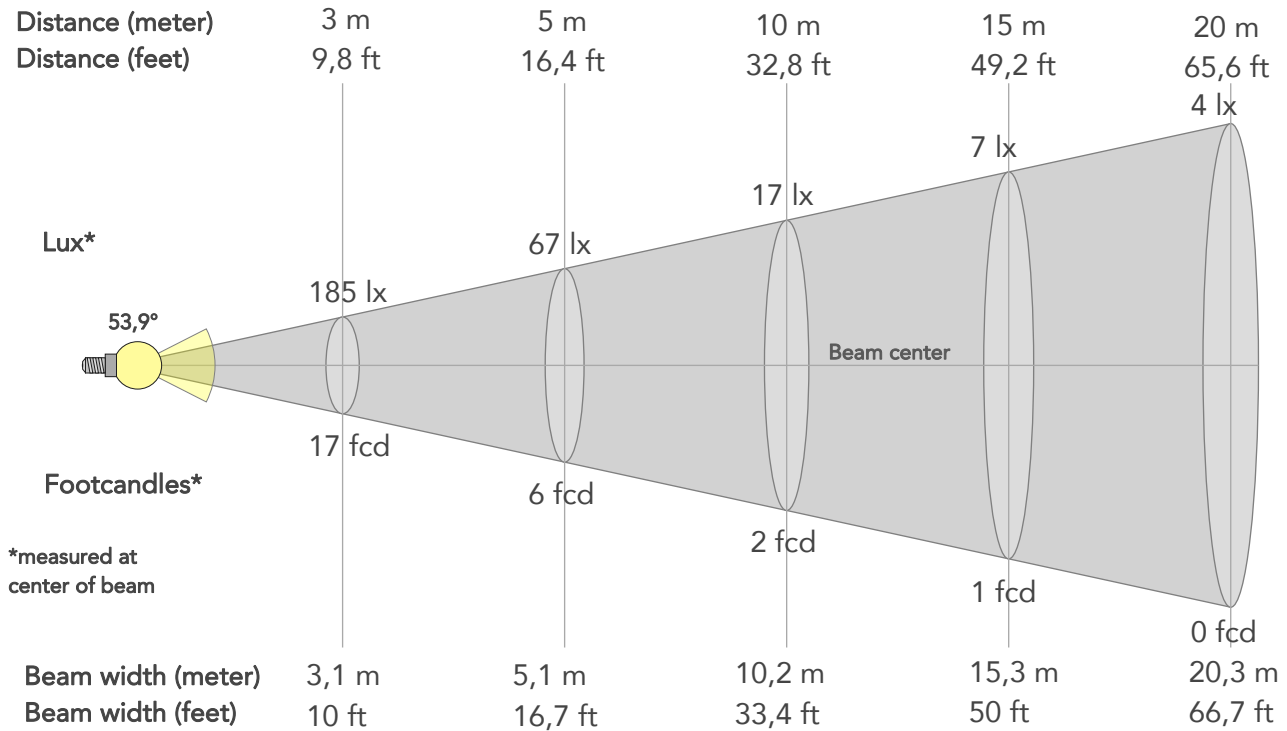

## BEAM INTENSITIES AND WIDTHS

Distance	1m	2m	3m	4m	5m	7,5m	10m	15m	20m	25m	30m	40m	50m
Distance	3,3ft	6,6ft	9,8ft	13,1ft	16,4ft	24,6ft	32,8ft	49,2ft	65,6ft	82ft	98,4ft	131,2ft	164ft
Lux	1665lx	416lx	185lx	104lx	67lx	30lx	17lx	7lx	4lx	3lx	2lx	1lx	1lx
Footcand.	155fcd	39fcd	17fcd	10fcd	6fcd	3fcd	2fcd	1fcd	0fcd	0fcd	0fcd	0fcd	0fcd
Beam wid.	1m	2m	3,1m	4,1m	5,1m	7,6m	10,2m	15,3m	20,3m	25,4m	30,5m	40,7m	50,8m
Beam wid.	3,4ft	6,7ft	10ft	13,3ft	16,7ft	25ft	33,4ft	50ft	66,7ft	83,4ft	100,1ft	133,4ft	166,8ft

## LINEAR DISTRIBUTION DIAGRAM

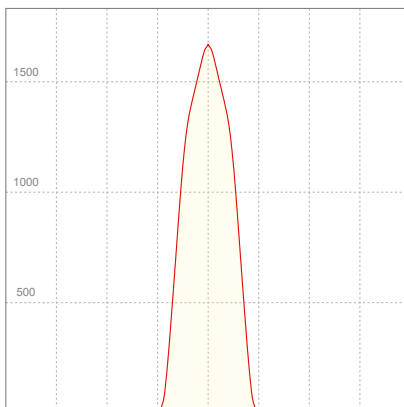

## ELECTRICAL SPECIFICATIONS

Input voltage	Input current	Input power	Effeciency
228V	0,215A	44,4W	26lm/W

Power FC
0,91



## ISO CANDELA DIAGRAM

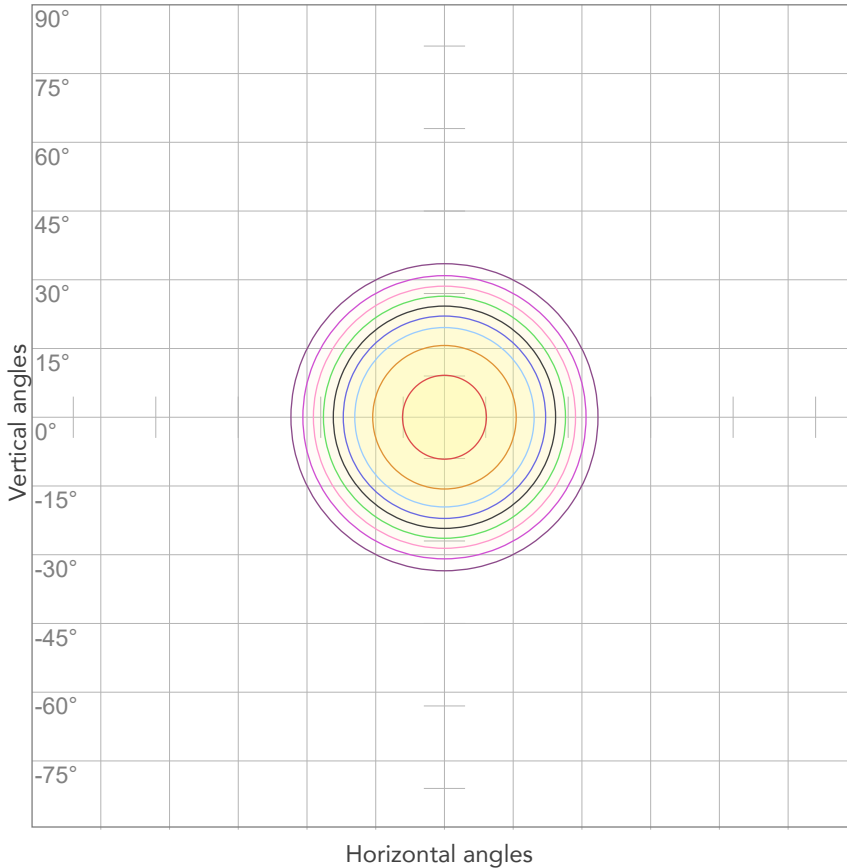

10%	167 cd
20%	333 cd
30%	500 cd
40%	666 cd
50%	833 cd
60%	999 cd
70%	1166 cd
80%	1332 cd

Conditions:

Number of c-planes: 2

Candela at center: 1665 cd

## ISO LUX DIAGRAM

MH: 10,0 m

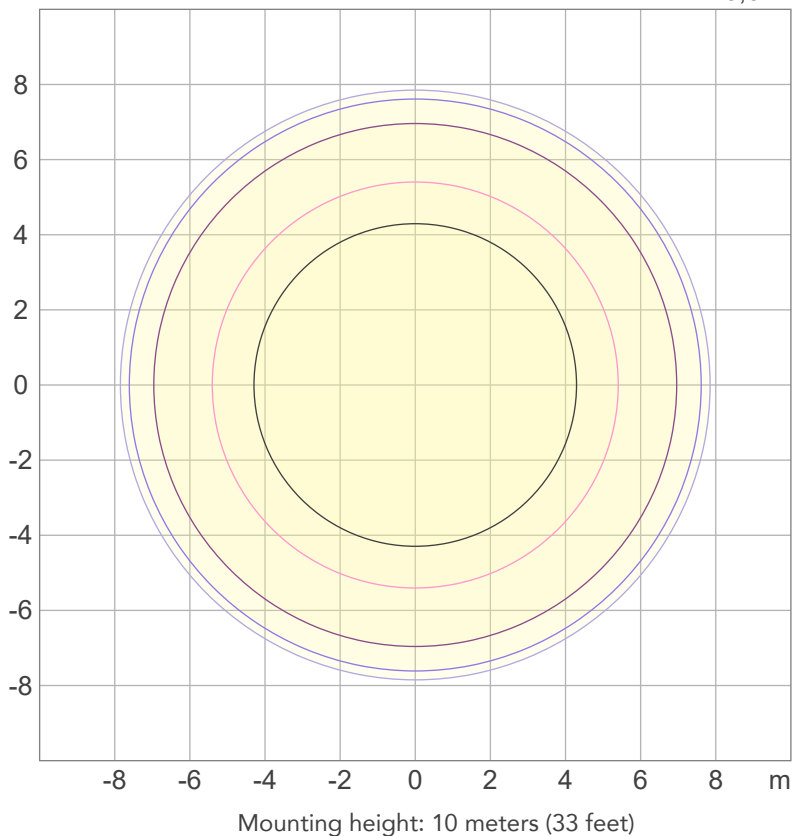

3%	0,500 lx
5%	0,833 lx
10%	1,67 lx
30%	5,00 lx
50%	8,33 lx

Conditions:

Number of c-planes: 2

Lux at center: 16,7 lx

*Lux distribution on a surface when lamp is mounted at 10 meters from the surface.*



Total lumen output:

857 lm

Peak candela output:

5656 cd

PRODUCT NAME:

ECLFRCTPS

MEASURAMENT CONDITIONS:

Beam angle:

Med Zoom

Target:

Green - HB

Operator:

Salvatore Giglio

Date and time:

02/10/2023 17:22:39

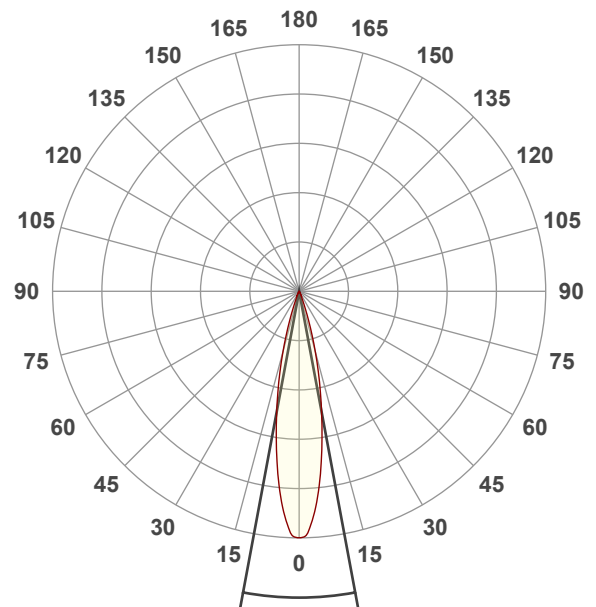

Beam angle 50%: 21,1°

Field angle 10%: 37,5°

Cut off angle 2.5%: 46°

Spectra

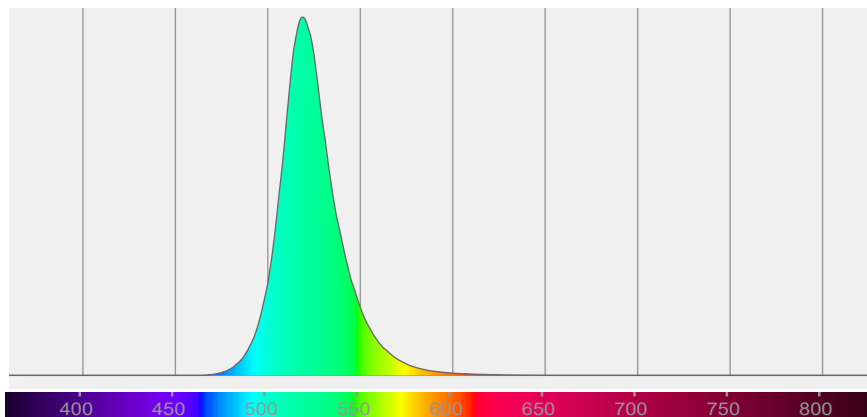

# BEAM DETAILS



Beam angle 50%	Field angle 10%	Cut off angle 2,5%	Intensity ratio in 120° cone	Intensity ratio in 90° cone
21,1°	37,5°	46°	100,0%	99,9%

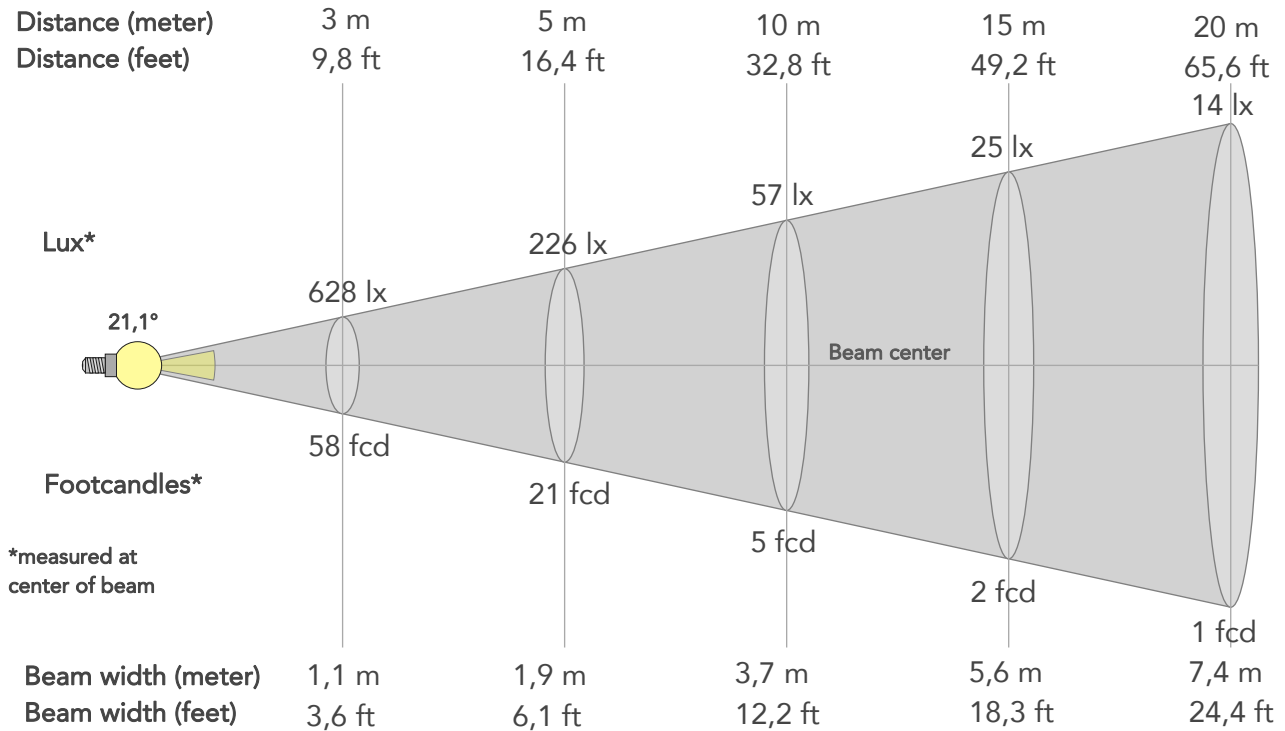

## BEAM INTENSITIES AND WIDTHS

Distance	1m	2m	3m	4m	5m	7,5m	10m	15m	20m	25m	30m	40m	50m
Distance	3,3ft	6,6ft	9,8ft	13,1ft	16,4ft	24,6ft	32,8ft	49,2ft	65,6ft	82ft	98,4ft	131,2ft	164ft
Lux	5656lx	1414lx	628lx	353lx	226lx	101lx	57lx	25lx	14lx	9lx	6lx	4lx	2lx
Footcand.	525fcd	131fcd	58fcd	33fcd	21fcd	9fcd	5fcd	2fcd	1fcd	1fcd	1fcd	0fcd	0fcd
Beam wid.	0,4m	0,7m	1,1m	1,5m	1,9m	2,8m	3,7m	5,6m	7,4m	9,3m	11,2m	14,9m	18,6m
Beam wid.	1,2ft	2,5ft	3,6ft	4,9ft	6,1ft	9,2ft	12,2ft	18,3ft	24,4ft	30,5ft	36,6ft	48,9ft	61,1ft

## LINEAR DISTRIBUTION DIAGRAM

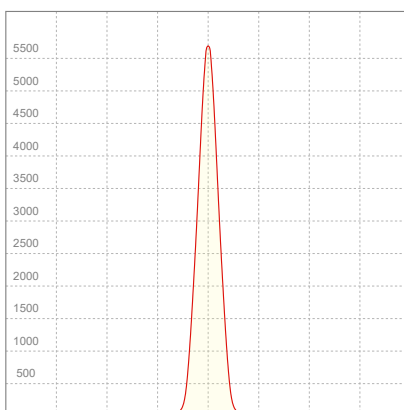

## ELECTRICAL SPECIFICATIONS

Input voltage	Input current	Input power	Effeciency
227V	0,218A	44,6W	19lm/W

Power FC
0,9

## ISO CANDELA DIAGRAM

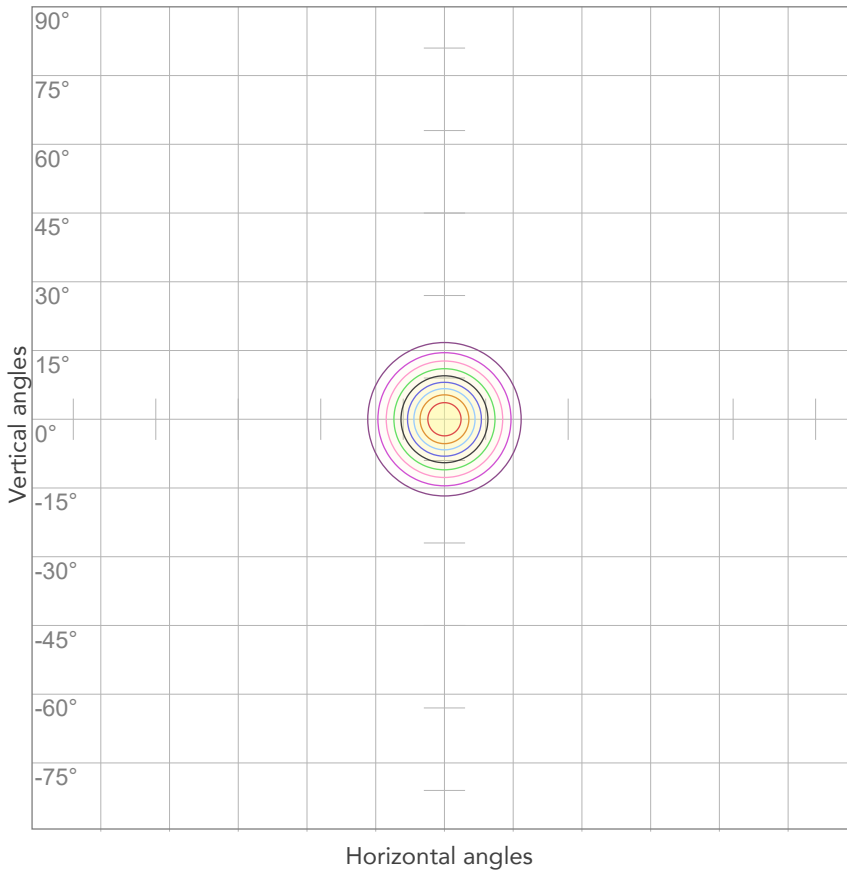

10%	566 cd
20%	1131 cd
30%	1697 cd
40%	2262 cd
50%	2828 cd
60%	3394 cd
70%	3959 cd
80%	4525 cd

Conditions:

Number of c-planes: 2

Candela at center: 5656 cd

## ISO LUX DIAGRAM

MH: 10,0 m

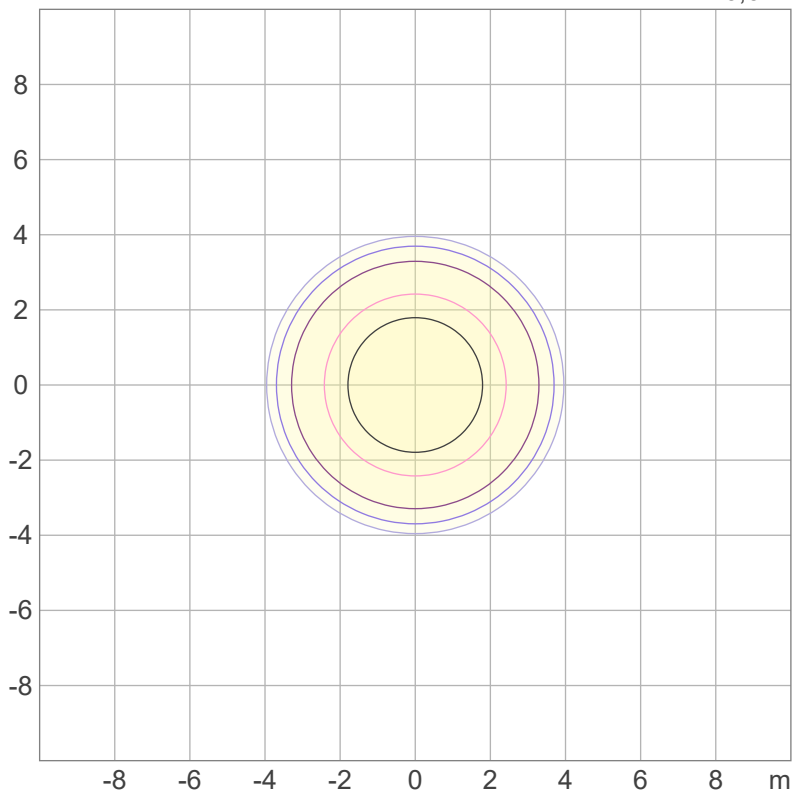

Mounting height: 10 meters (33 feet)

3%	1,70 lx
5%	2,83 lx
10%	5,66 lx
30%	17,0 lx
50%	28,3 lx

Conditions:

Number of c-planes: 2

Lux at center: 56,6 lx

*Lux distribution on a surface when lamp is mounted at 10 meters from the surface.*



Total lumen output:

438 lm

Peak candela output:

13055 cd

PRODUCT NAME:

ECLFRCTPS

MEASURAMENT CONDITIONS:

Beam angle:

Min Zoom

Target:

Green - HB

Operator:

Salvatore Giglio

Date and time:

02/10/2023 16:32:42

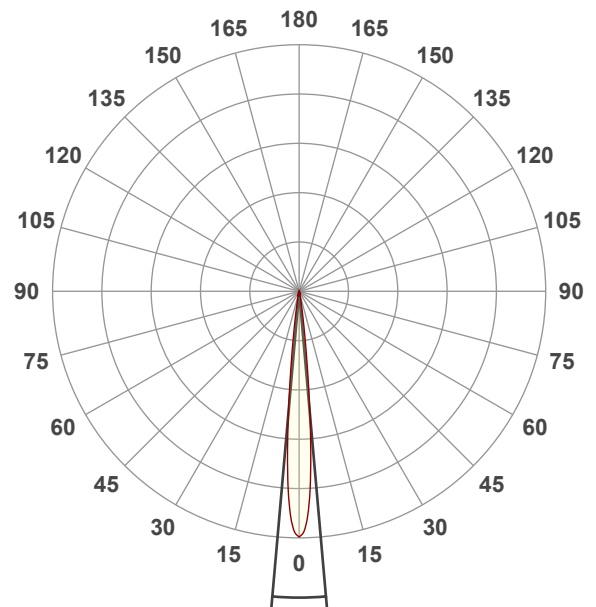

Beam angle 50%: 10°

Field angle 10%: 17°

Cut off angle 2.5%: 22,6°

Spectra

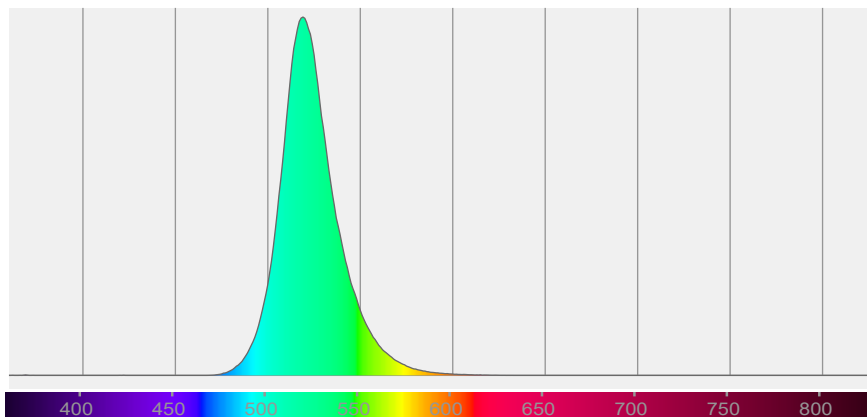

# BEAM DETAILS



Beam angle 50%	Field angle 10%	Cut off angle 2,5%	Intensity ratio in 120° cone	Intensity ratio in 90° cone
10°	17°	22,6°	100,0%	100,0%

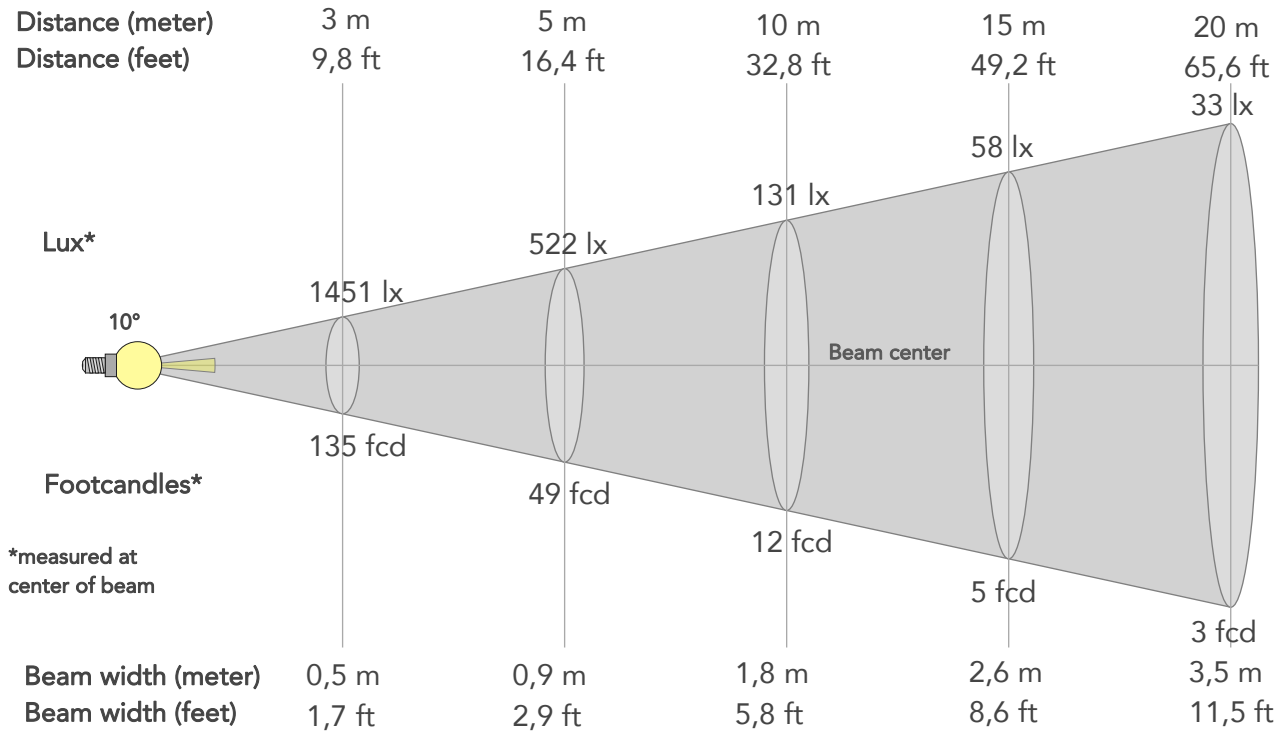

## BEAM INTENSITIES AND WIDTHS

Distance	1m	2m	3m	4m	5m	7,5m	10m	15m	20m	25m	30m	40m	50m
Distance	3,3ft	6,6ft	9,8ft	13,1ft	16,4ft	24,6ft	32,8ft	49,2ft	65,6ft	82ft	98,4ft	131,2ft	164ft
Lux	13055lx	3264lx	1451lx	816lx	522lx	232lx	131lx	58lx	33lx	21lx	15lx	8lx	5lx
Footcand.	1213fcd	303fcd	135fcd	76fcd	49fcd	22fcd	12fcd	5fcd	3fcd	2fcd	1fcd	1fcd	0fcd
Beam wid.	0,2m	0,4m	0,5m	0,7m	0,9m	1,3m	1,8m	2,6m	3,5m	4,4m	5,3m	7m	8,8m
Beam wid.	0,6ft	1,2ft	1,7ft	2,3ft	2,9ft	4,3ft	5,8ft	8,6ft	11,5ft	14,4ft	17,3ft	23,1ft	28,8ft

## LINEAR DISTRIBUTION DIAGRAM

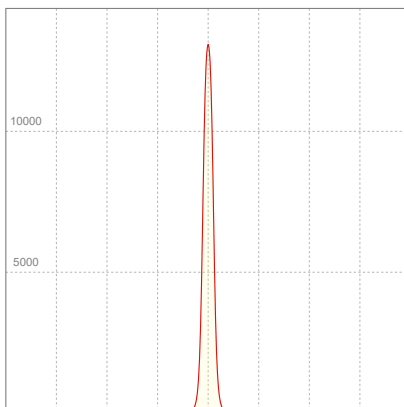

## ELECTRICAL SPECIFICATIONS

Input voltage	Input current	Input power	Effeciency
227V	0,216A	44,6W	10lm/W

Power FC
0,91

## ISO CANDELA DIAGRAM

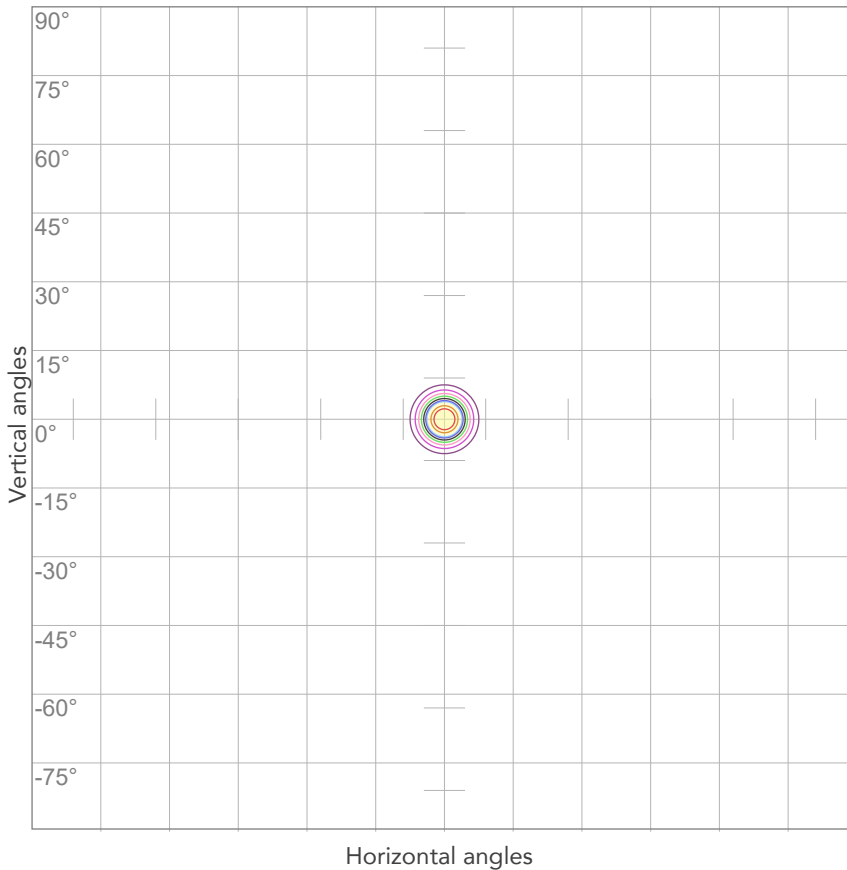

10%	1305 cd
20%	2611 cd
30%	3916 cd
40%	5222 cd
50%	6527 cd
60%	7833 cd
70%	9138 cd
80%	10444 cd

Conditions:

Number of c-planes: 2

Candela at center: 13055 cd

## ISO LUX DIAGRAM

MH: 10,0 m

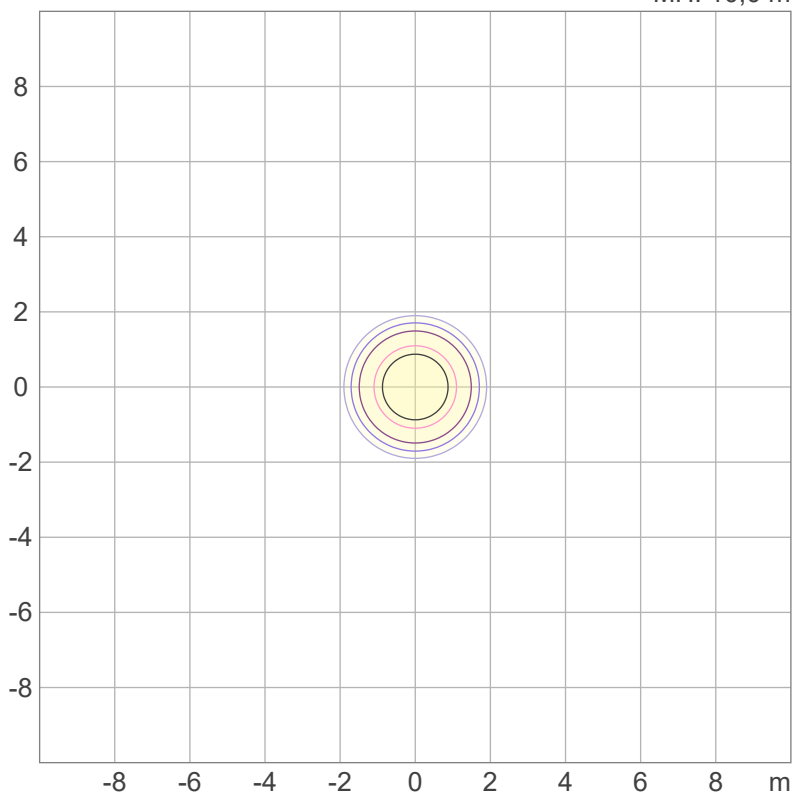

Mounting height: 10 meters (33 feet)

3%	3,92 lx
5%	6,53 lx
10%	13,1 lx
30%	39,2 lx
50%	65,3 lx

Conditions:

Number of c-planes: 2

Lux at center: 131 lx

*Lux distribution on a surface when lamp is mounted at 10 meters from the surface.*



Total lumen output:

197 lm

Peak candela output:

297 cd

PRODUCT NAME:

ECLFRCTPS

MEASURAMENT CONDITIONS:

Beam angle:

Max Zoom

Target:

Blue - HB

Operator:

Salvatore Giglio

Date and time:

02/10/2023 16:47:11

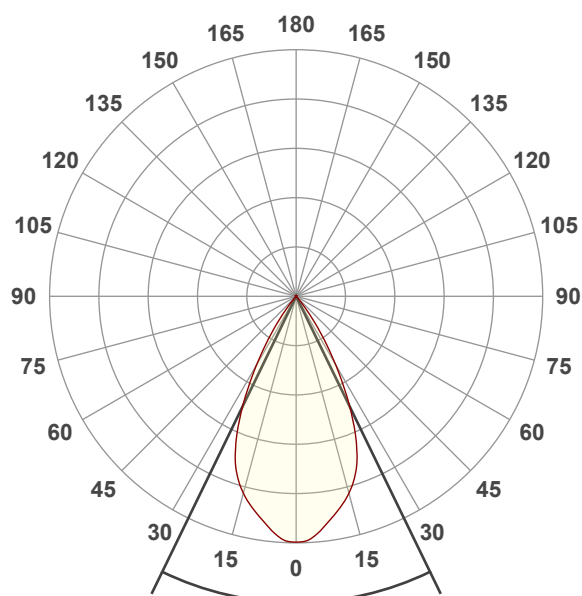

Spectra

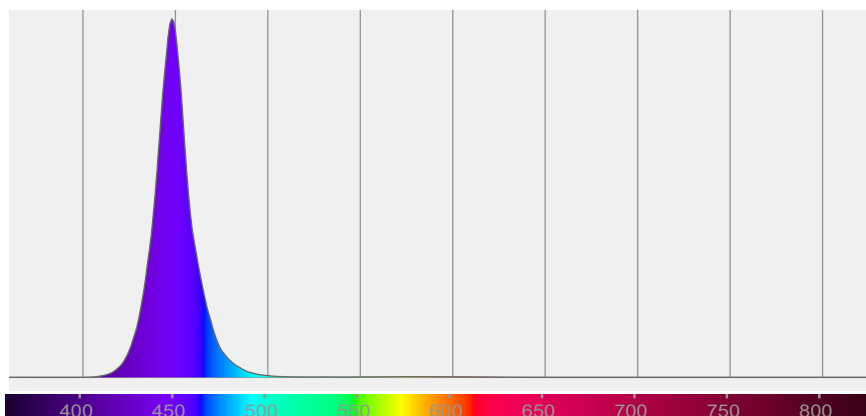



# BEAM DETAILS



Beam angle 50%	Field angle 10%	Cut off angle 2,5%	Intensity ratio in 120° cone	Intensity ratio in 90° cone
51,8°	73°	81°	100,0%	99,6%

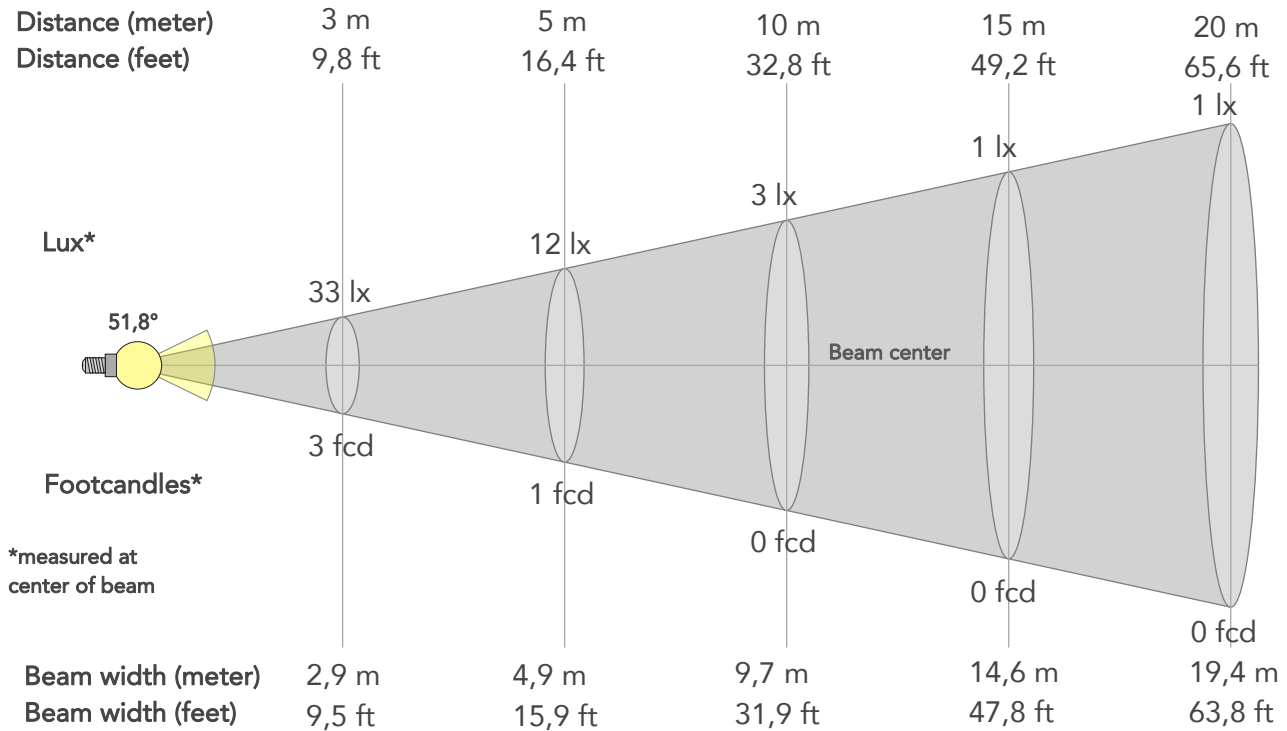

## BEAM INTENSITIES AND WIDTHS

Distance	1m	2m	3m	4m	5m	7,5m	10m	15m	20m	25m	30m	40m	50m
Distance	3,3ft	6,6ft	9,8ft	13,1ft	16,4ft	24,6ft	32,8ft	49,2ft	65,6ft	82ft	98,4ft	131,2ft	164ft
Lux	297lx	74lx	33lx	19lx	12lx	5lx	3lx	1lx	1lx	0lx	0lx	0lx	0lx
Footcand.	28fcd	7fcd	3fcd	2fcd	1fcd	0fcd	0fcd	0fcd	0fcd	0fcd	0fcd	0fcd	0fcd
Beam wid.	1m	1,9m	2,9m	3,9m	4,9m	7,3m	9,7m	14,6m	19,4m	24,3m	29,2m	38,9m	48,6m
Beam wid.	3,2ft	6,4ft	9,5ft	12,7ft	15,9ft	23,9ft	31,9ft	47,8ft	63,8ft	79,7ft	95,6ft	127,5ft	159,4ft

## LINEAR DISTRIBUTION DIAGRAM

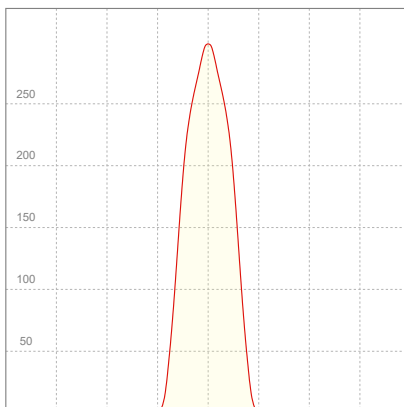

## ELECTRICAL SPECIFICATIONS

Input voltage	Input current	Input power	Effeciency
227V	0,220A	45,4W	4lm/W

Power FC
0,91

## ISO CANDELA DIAGRAM

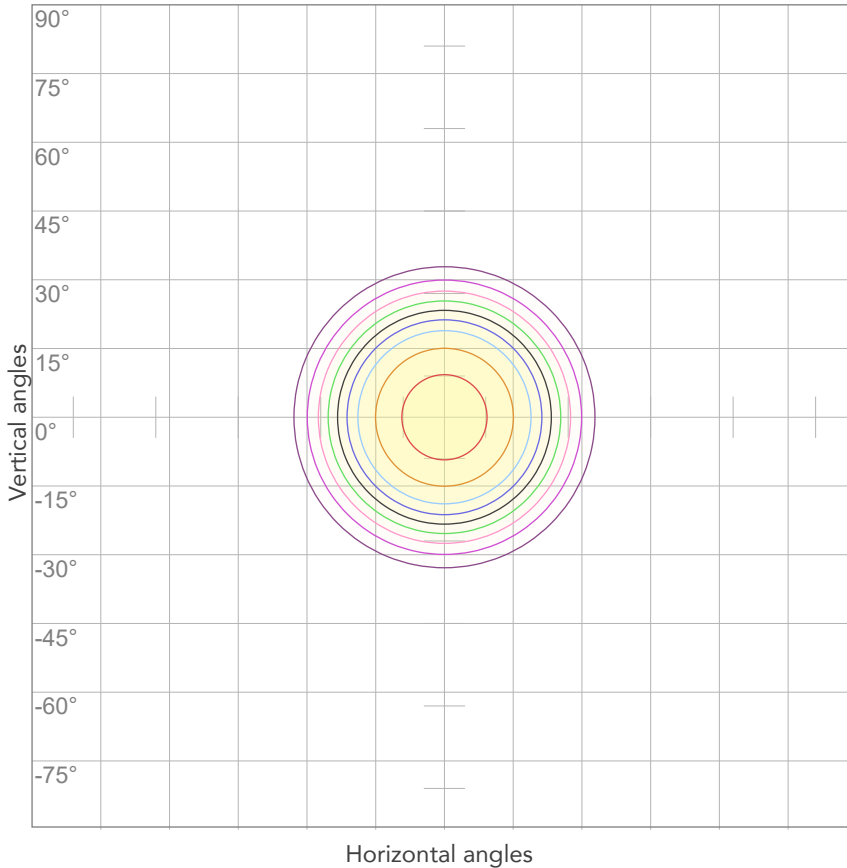

10%	30 cd
20%	59 cd
30%	89 cd
40%	119 cd
50%	149 cd
60%	178 cd
70%	208 cd
80%	238 cd

Conditions:

Number of c-planes: 2  
Candela at center: 297 cd

## ISO LUX DIAGRAM

MH: 10,0 m

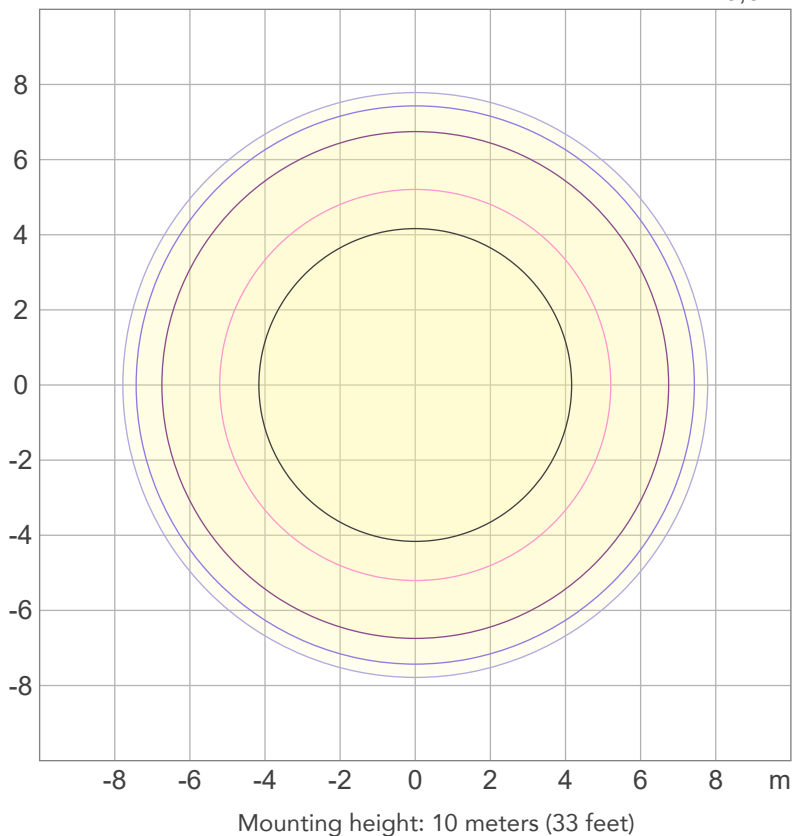

3%	89,2m lx
5%	0,149 lx
10%	0,297 lx
30%	0,892 lx
50%	1,49 lx

Conditions:

Number of c-planes: 2  
Lux at center: 2,97 lx

*Lux distribution on a surface when lamp is mounted at 10 meters from the surface.*



Total lumen output:

142 lm

Peak candela output:

1036 cd

PRODUCT NAME:

ECLFRCTPS

MEASURAMENT CONDITIONS:

Beam angle:

Med Zoom

Target:

Blue - HB

Operator:

Salvatore Giglio

Date and time:

02/10/2023 17:23:59

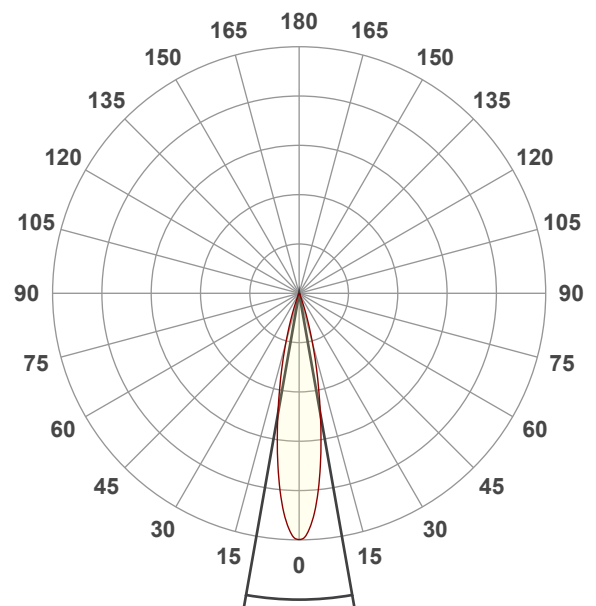

Beam angle 50%: 20°

Field angle 10%: 35,9°

Cut off angle 2.5%: 44,2°

Spectra

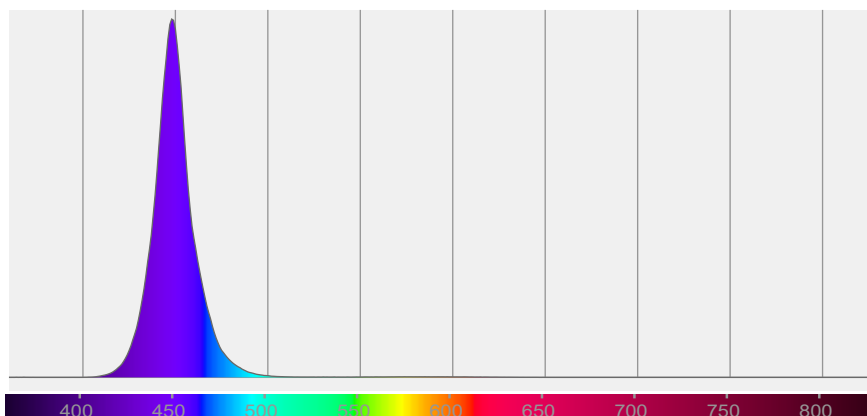

# BEAM DETAILS



Beam angle 50%	Field angle 10%	Cut off angle 2,5%	Intensity ratio in 120° cone	Intensity ratio in 90° cone
20°	35,9°	44,2°	100,0%	99,9%

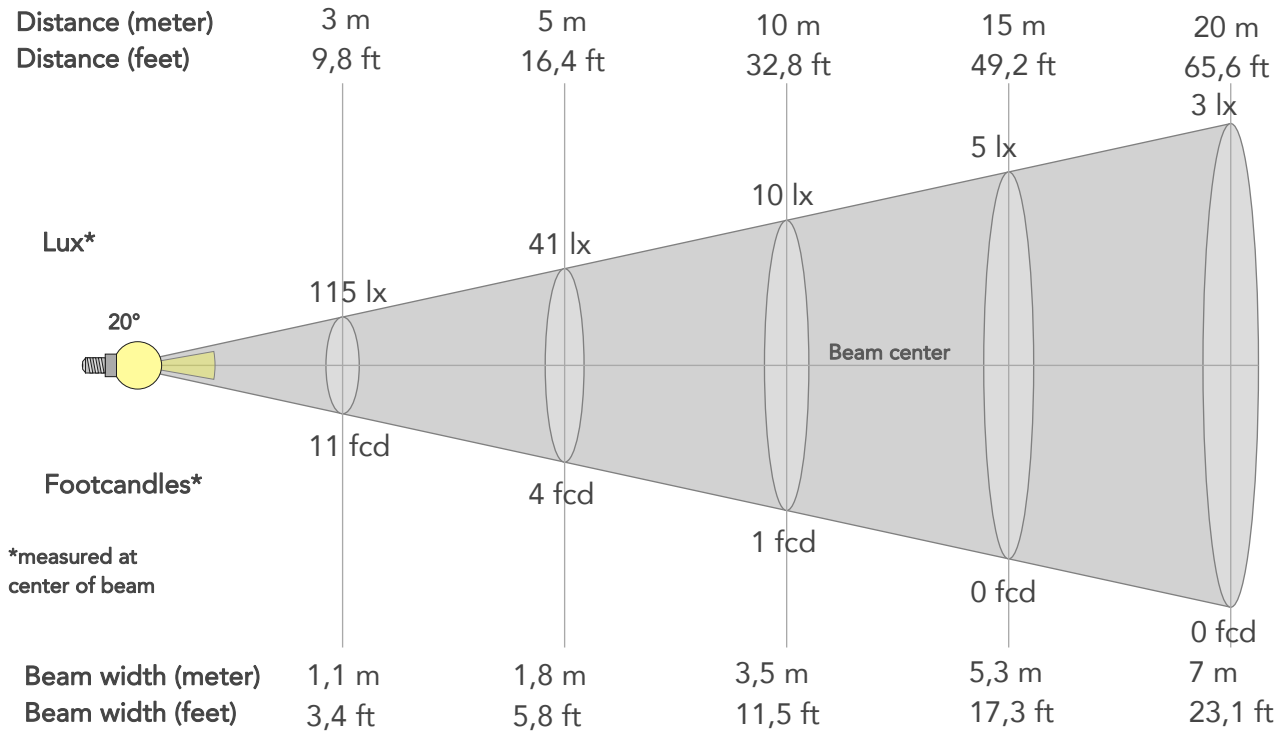

## BEAM INTENSITIES AND WIDTHS

Distance	1m	2m	3m	4m	5m	7,5m	10m	15m	20m	25m	30m	40m	50m
Distance	3,3ft	6,6ft	9,8ft	13,1ft	16,4ft	24,6ft	32,8ft	49,2ft	65,6ft	82ft	98,4ft	131,2ft	164ft
Lux	1036lx	259lx	115lx	65lx	41lx	18lx	10lx	5lx	3lx	2lx	1lx	1lx	0lx
Footcand.	96fcd	24fcd	11fcd	6fcd	4fcd	2fcd	1fcd	0fcd	0fcd	0fcd	0fcd	0fcd	0fcd
Beam wid.	0,4m	0,7m	1,1m	1,4m	1,8m	2,6m	3,5m	5,3m	7m	8,8m	10,6m	14,1m	17,6m
Beam wid.	1,2ft	2,3ft	3,4ft	4,6ft	5,8ft	8,7ft	11,5ft	17,3ft	23,1ft	28,9ft	34,6ft	46,2ft	57,7ft

## LINEAR DISTRIBUTION DIAGRAM

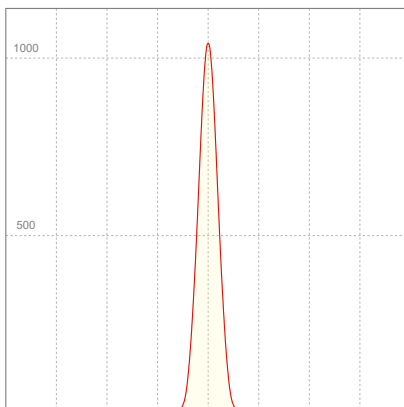

## ELECTRICAL SPECIFICATIONS

Input voltage	Input current	Input power	Effeciency
226V	0,222A	45,5W	3lm/W

Power FC
0,91

## ISO CANDELA DIAGRAM

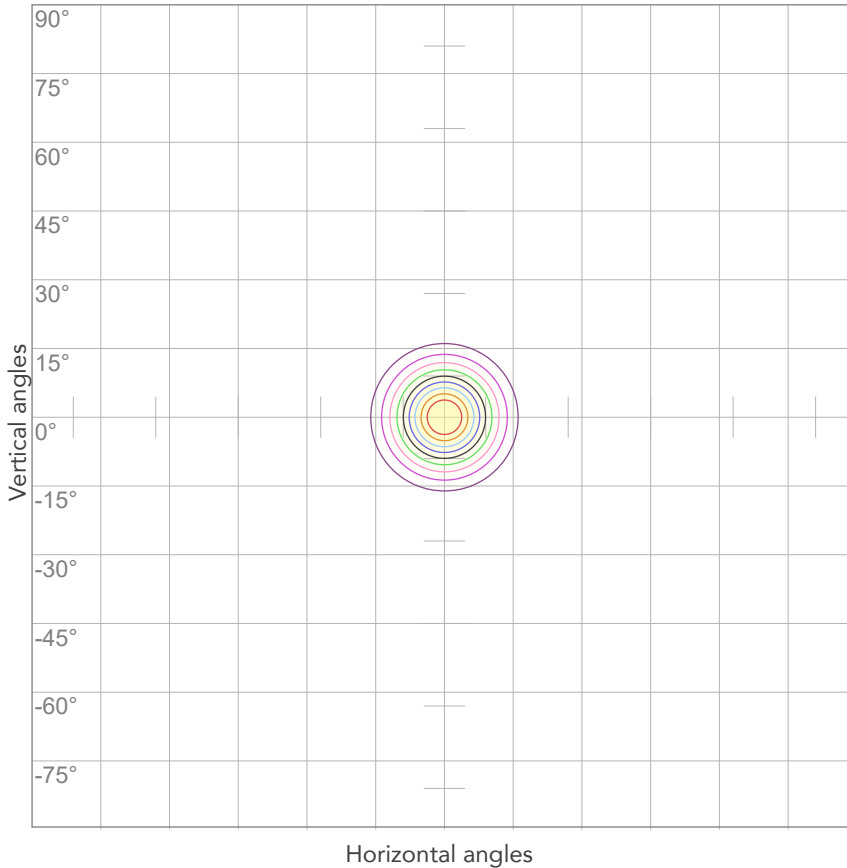

10%	104 cd
20%	207 cd
30%	311 cd
40%	414 cd
50%	518 cd
60%	622 cd
70%	725 cd
80%	829 cd

Conditions:

Number of c-planes: 2

Candela at center: 1036 cd

## ISO LUX DIAGRAM

MH: 10,0 m

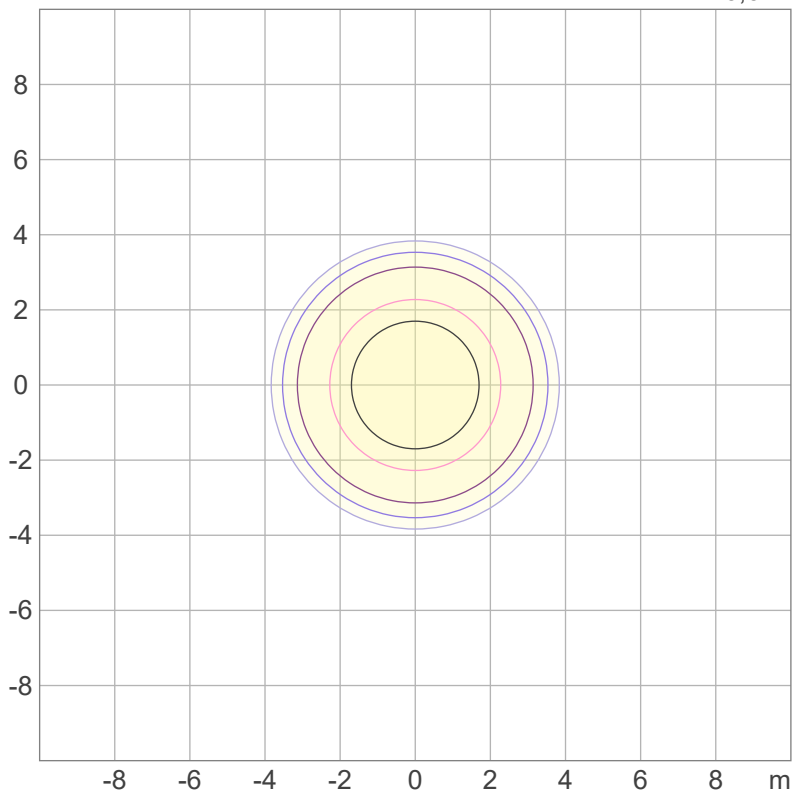

3%	0,311 lx
5%	0,518 lx
10%	1,04 lx
30%	3,11 lx
50%	5,18 lx

Conditions:

Number of c-planes: 2

Lux at center: 10,4 lx

*Lux distribution on a surface when lamp is mounted at 10 meters from the surface.*



Total lumen output:

81,0 lm

Peak candela output:

2320 cd

PRODUCT NAME:

ECLFRCTPS

MEASURAMENT CONDITIONS:

Beam angle:

Min Zoom

Target:

Blue - HB

Operator:

Salvatore Giglio

Date and time:

02/10/2023 16:34:03

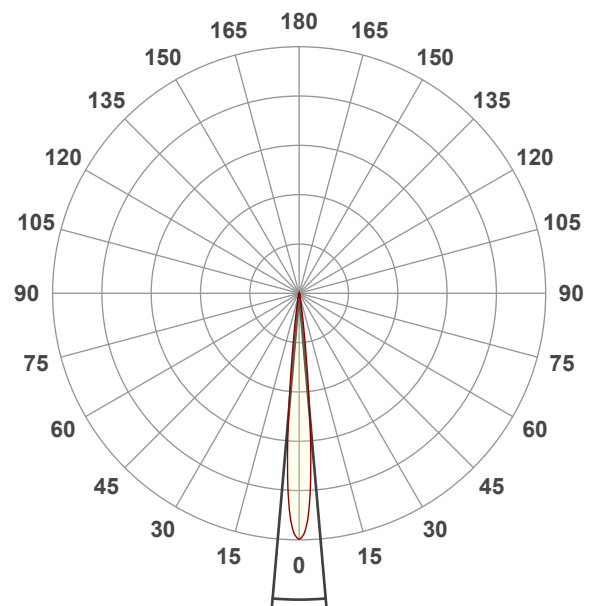

Beam angle 50%: 9,9°

Field angle 10%: 16,6°

Cut off angle 2.5%: 22,9°

Spectra

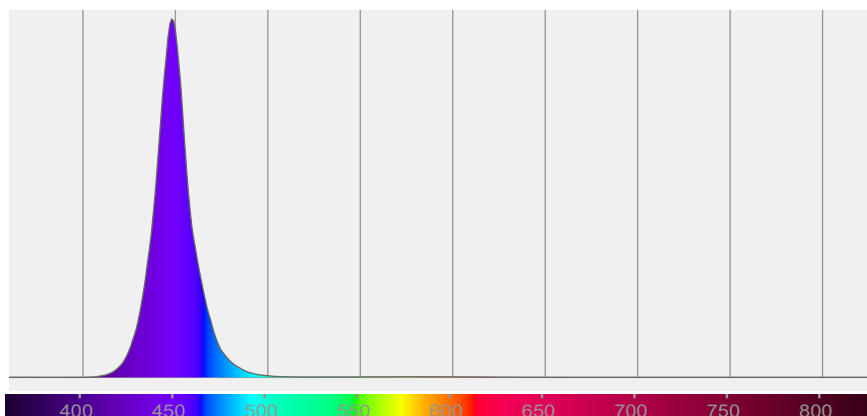

# BEAM DETAILS



Beam angle 50%	Field angle 10%	Cut off angle 2,5%	Intensity ratio in 120° cone	Intensity ratio in 90° cone
9,9°	16,6°	22,9°	100,0%	99,9%

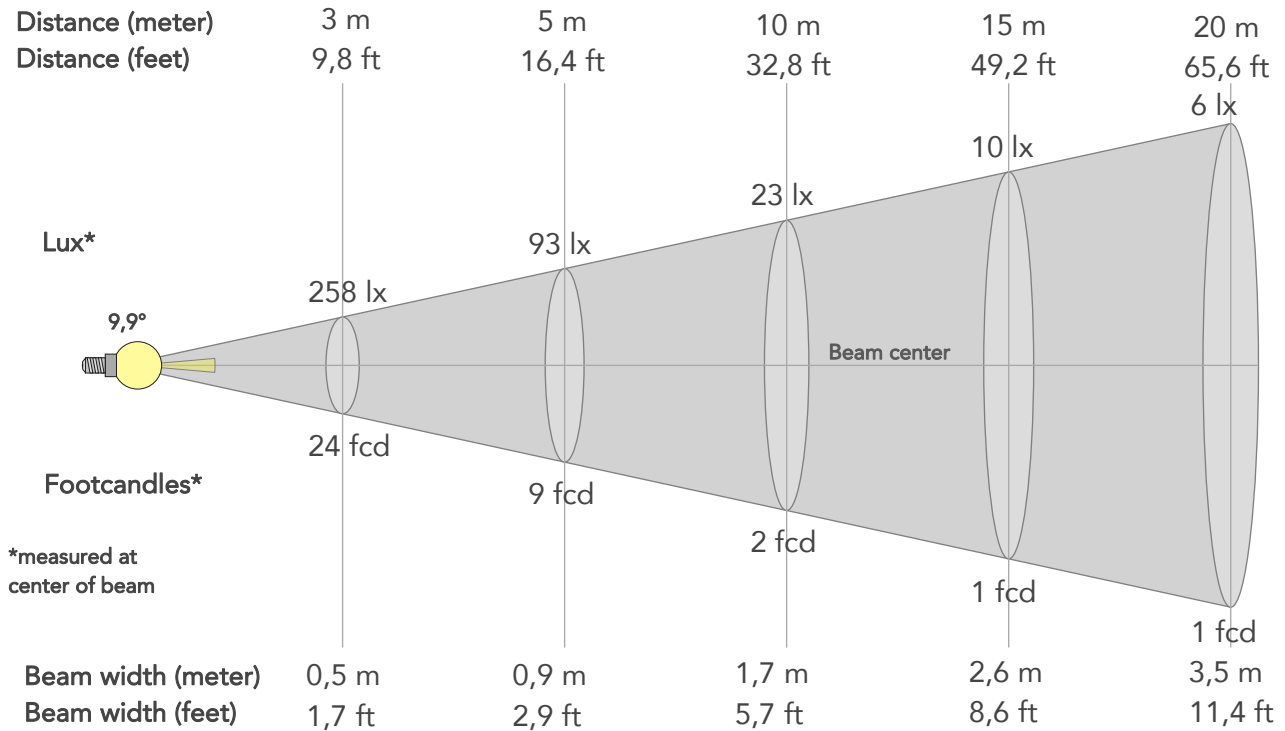

## BEAM INTENSITIES AND WIDTHS

Distance	1m	2m	3m	4m	5m	7,5m	10m	15m	20m	25m	30m	40m	50m
Distance	3,3ft	6,6ft	9,8ft	13,1ft	16,4ft	24,6ft	32,8ft	49,2ft	65,6ft	82ft	98,4ft	131,2ft	164ft
Lux	2320lx	580lx	258lx	145lx	93lx	41lx	23lx	10lx	6lx	4lx	3lx	1lx	1lx
Footcand.	216fcd	54fcd	24fcd	13fcd	9fcd	4fcd	2fcd	1fcd	1fcd	0fcd	0fcd	0fcd	0fcd
Beam wid.	0,2m	0,3m	0,5m	0,7m	0,9m	1,3m	1,7m	2,6m	3,5m	4,3m	5,2m	7m	8,7m
Beam wid.	0,6ft	1,1ft	1,7ft	2,3ft	2,9ft	4,3ft	5,7ft	8,6ft	11,4ft	14,3ft	17,1ft	22,8ft	28,5ft

## LINEAR DISTRIBUTION DIAGRAM

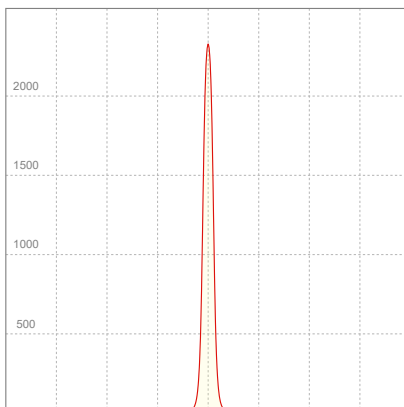

## ELECTRICAL SPECIFICATIONS

Input voltage	Input current	Input power	Effeciency
227V	0,219A	45,5W	2lm/W

Power FC
0,91

## ISO CANDELA DIAGRAM

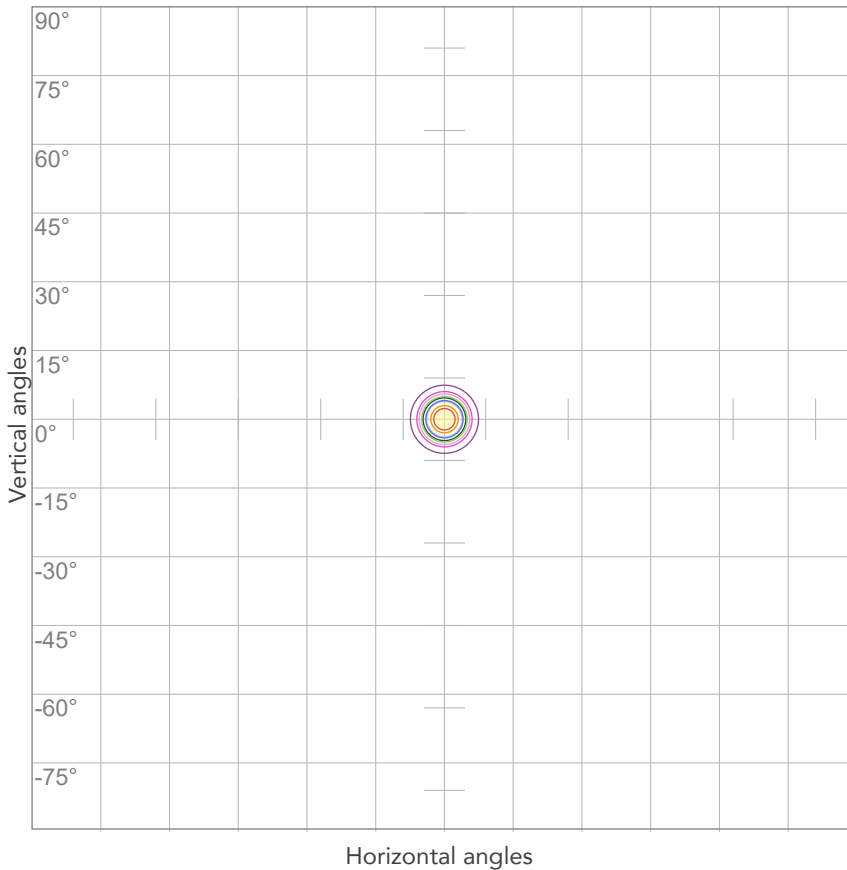

10%	232 cd
20%	464 cd
30%	696 cd
40%	928 cd
50%	1160 cd
60%	1392 cd
70%	1624 cd
80%	1856 cd

Conditions:

Number of c-planes: 2

Candela at center: 2320 cd

## ISO LUX DIAGRAM

MH: 10,0 m

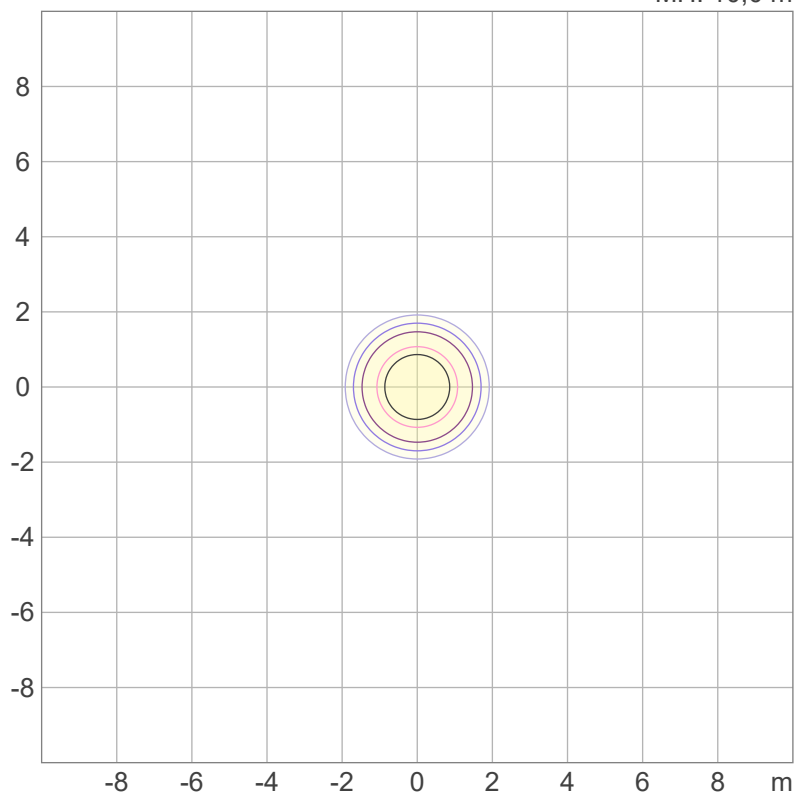

3%	0,696 lx
5%	1,16 lx
10%	2,32 lx
30%	6,96 lx
50%	11,6 lx

Conditions:

Number of c-planes: 2

Lux at center: 23,2 lx

*Lux distribution on a surface when lamp is mounted at 10 meters from the surface.*





Total lumen output:

177 lm

Peak candela output:

261 cd

PRODUCT NAME:

ECLFRCTPS

MEASUREMENT CONDITIONS:

Beam angle:

Max Zoom

Target:

Cyan - HB

Operator:

Salvatore Giglio

Date and time:

02/10/2023 16:48:36

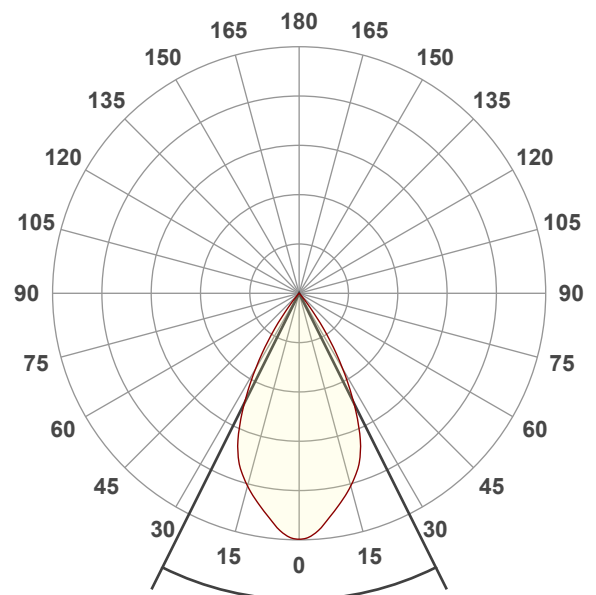

Beam angle 50%: 53°

Field angle 10%: 73,7°

Cut off angle 2.5%: 80,6°

Spectra

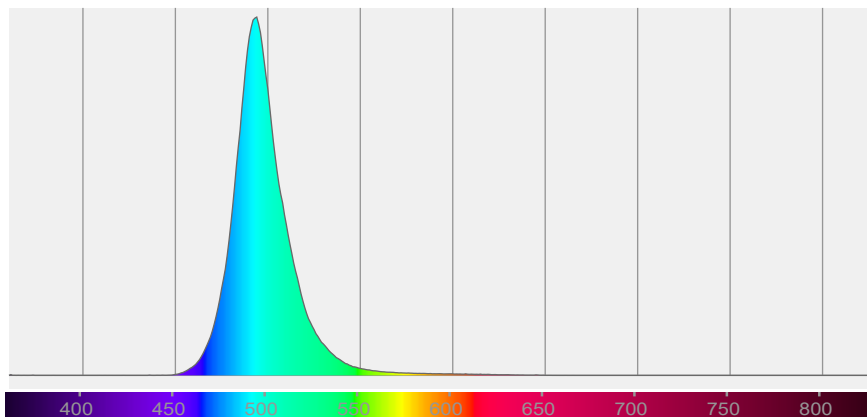

# BEAM DETAILS



Beam angle 50%	Field angle 10%	Cut off angle 2,5%	Intensity ratio in 120° cone	Intensity ratio in 90° cone
53°	73,7°	80,6°	100,0%	99,7%

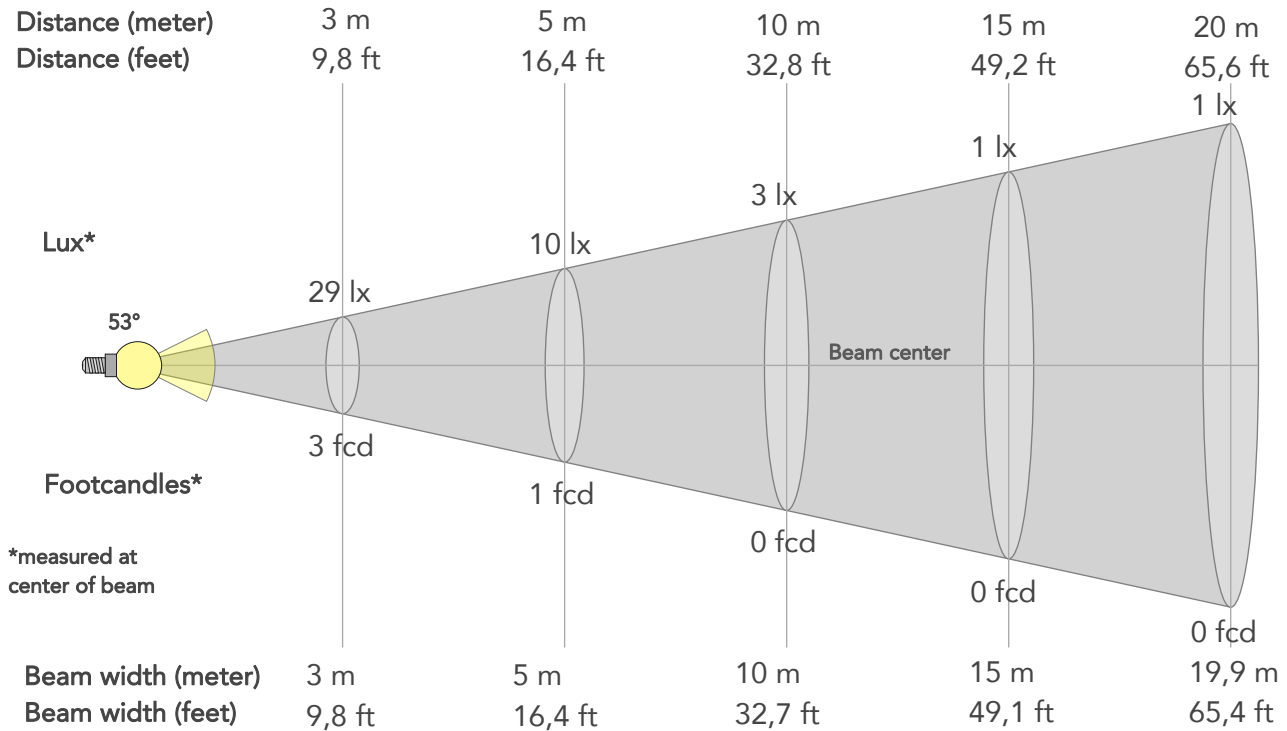

## BEAM INTENSITIES AND WIDTHS

Distance	1m	2m	3m	4m	5m	7,5m	10m	15m	20m	25m	30m	40m	50m
Distance	3,3ft	6,6ft	9,8ft	13,1ft	16,4ft	24,6ft	32,8ft	49,2ft	65,6ft	82ft	98,4ft	131,2ft	164ft
Lux	261lx	65lx	29lx	16lx	10lx	5lx	3lx	1lx	1lx	0lx	0lx	0lx	0lx
Footcand.	24fcd	6fcd	3fcd	2fcd	1fcd	0fcd	0fcd	0fcd	0fcd	0fcd	0fcd	0fcd	0fcd
Beam wid.	1m	2m	3m	4m	5m	7,5m	10m	15m	19,9m	24,9m	29,9m	39,9m	49,9m
Beam wid.	3,3ft	6,6ft	9,8ft	13,1ft	16,4ft	24,5ft	32,7ft	49,1ft	65,4ft	81,8ft	98,1ft	130,9ft	163,6ft

## LINEAR DISTRIBUTION DIAGRAM

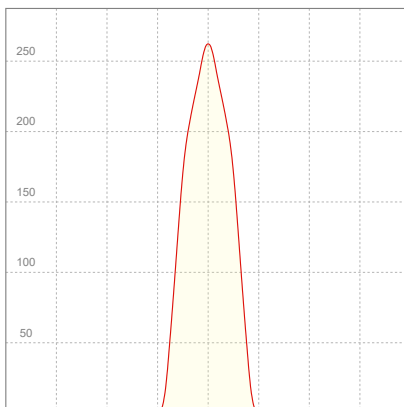

## ELECTRICAL SPECIFICATIONS

Input voltage	Input current	Input power	Effeciency
228V	0,123A	16,8W	11lm/W

Power FC
0,6

## ISO CANDELA DIAGRAM

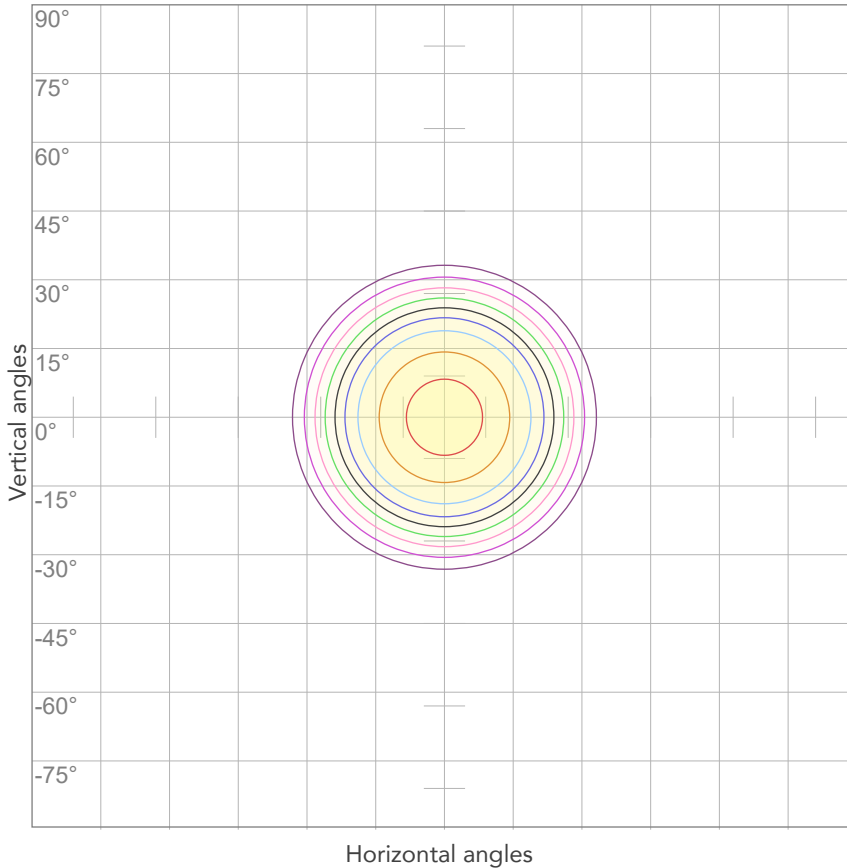

10%	26 cd
20%	52 cd
30%	78 cd
40%	105 cd
50%	131 cd
60%	157 cd
70%	183 cd
80%	209 cd

Conditions:

Number of c-planes: 2  
Candela at center: 261 cd

## ISO LUX DIAGRAM

MH: 10,0 m

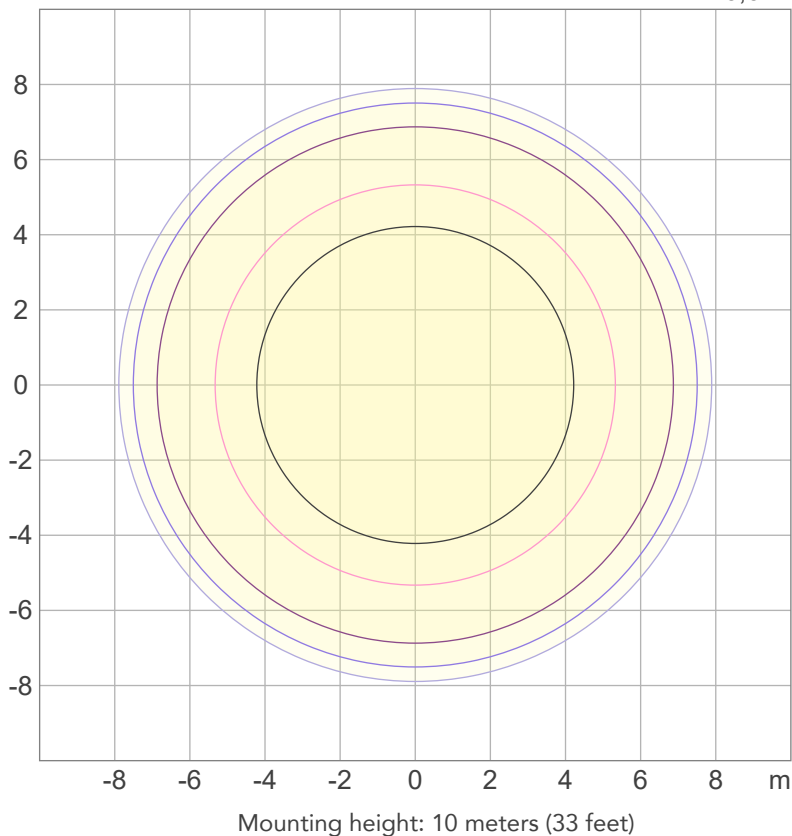

3%	78,4m lx
5%	0,131 lx
10%	0,261 lx
30%	0,784 lx
50%	1,31 lx

Conditions:

Number of c-planes: 2  
Lux at center: 2,61 lx

*Lux distribution on a surface when lamp is mounted at 10 meters from the surface.*



Total lumen output:

128 lm

Peak candela output:

890 cd

PRODUCT NAME:

ECLFRCTPS

MEASURAMENT CONDITIONS:

Beam angle:

Med Zoom

Target:

Cyan - HB

Operator:

Salvatore Giglio

Date and time:

02/10/2023 17:25:20

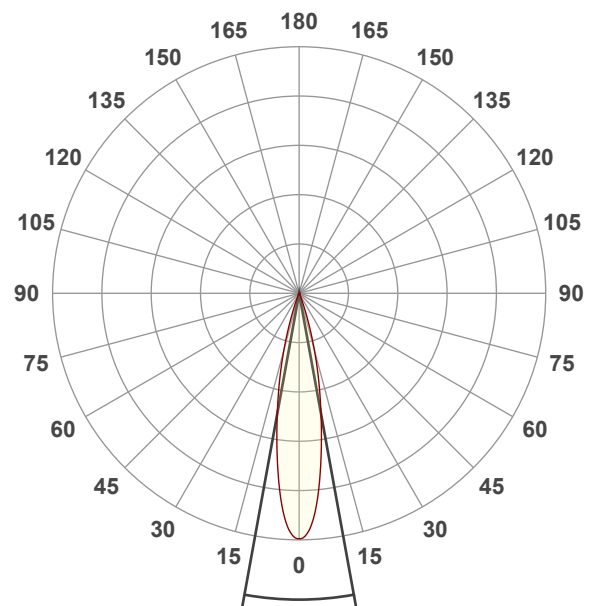

Beam angle 50%: 20,6°

Field angle 10%: 36,7°

Cut off angle 2.5%: 44,6°

Spectra

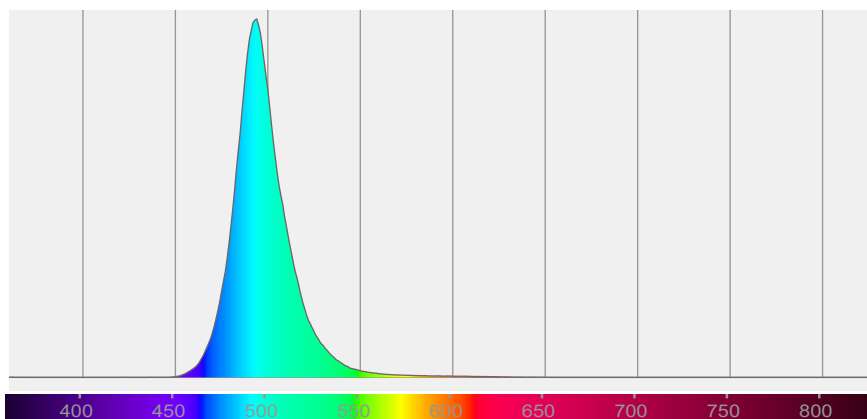

# BEAM DETAILS



Beam angle 50%	Field angle 10%	Cut off angle 2,5%	Intensity ratio in 120° cone	Intensity ratio in 90° cone
20,6°	36,7°	44,6°	100,0%	100,0%

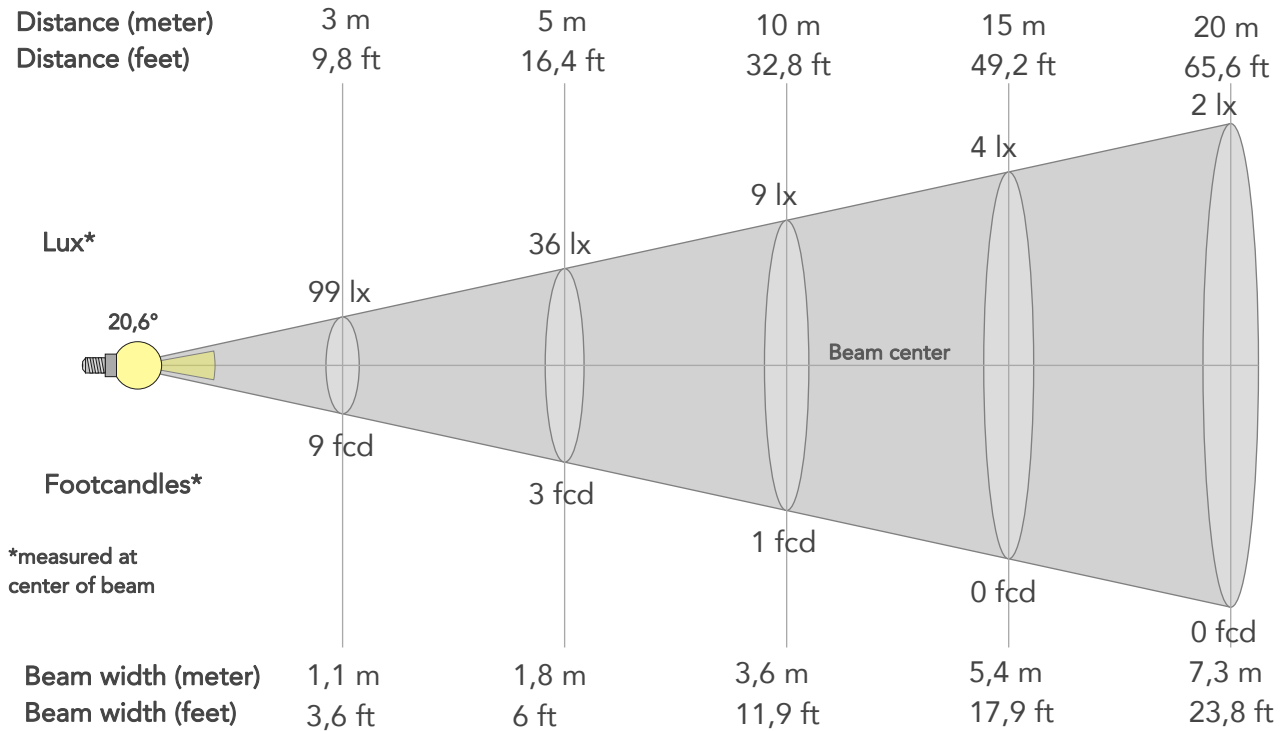

## BEAM INTENSITIES AND WIDTHS

Distance	1m	2m	3m	4m	5m	7,5m	10m	15m	20m	25m	30m	40m	50m
Distance	3,3ft	6,6ft	9,8ft	13,1ft	16,4ft	24,6ft	32,8ft	49,2ft	65,6ft	82ft	98,4ft	131,2ft	164ft
Lux	890lx	222lx	99lx	56lx	36lx	16lx	9lx	4lx	2lx	1lx	1lx	1lx	0lx
Footcand.	83fcd	21fcd	9fcd	5fcd	3fcd	1fcd	1fcd	0fcd	0fcd	0fcd	0fcd	0fcd	0fcd
Beam wid.	0,4m	0,7m	1,1m	1,5m	1,8m	2,7m	3,6m	5,4m	7,3m	9,1m	10,9m	14,5m	18,1m
Beam wid.	1,2ft	2,4ft	3,6ft	4,8ft	6ft	8,9ft	11,9ft	17,9ft	23,8ft	29,8ft	35,7ft	47,6ft	59,5ft

## LINEAR DISTRIBUTION DIAGRAM

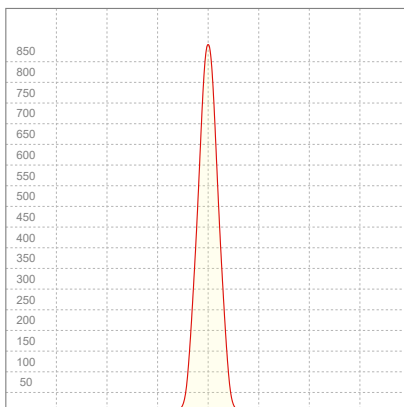

## ELECTRICAL SPECIFICATIONS

Input voltage	Input current	Input power	Effeciency
227V	0,128A	17,5W	7lm/W

Power FC
0,6

## ISO CANDELA DIAGRAM

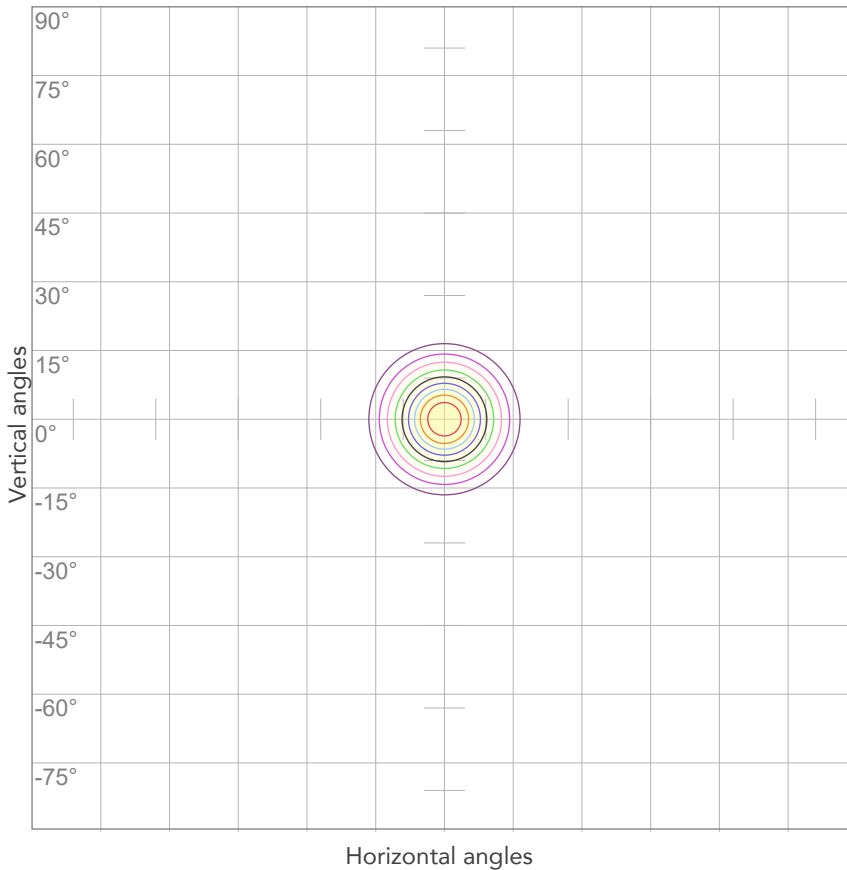

10%	89 cd
20%	178 cd
30%	267 cd
40%	356 cd
50%	445 cd
60%	534 cd
70%	623 cd
80%	712 cd

Conditions:

Number of c-planes: 2  
Candela at center: 890 cd

## ISO LUX DIAGRAM

MH: 10,0 m

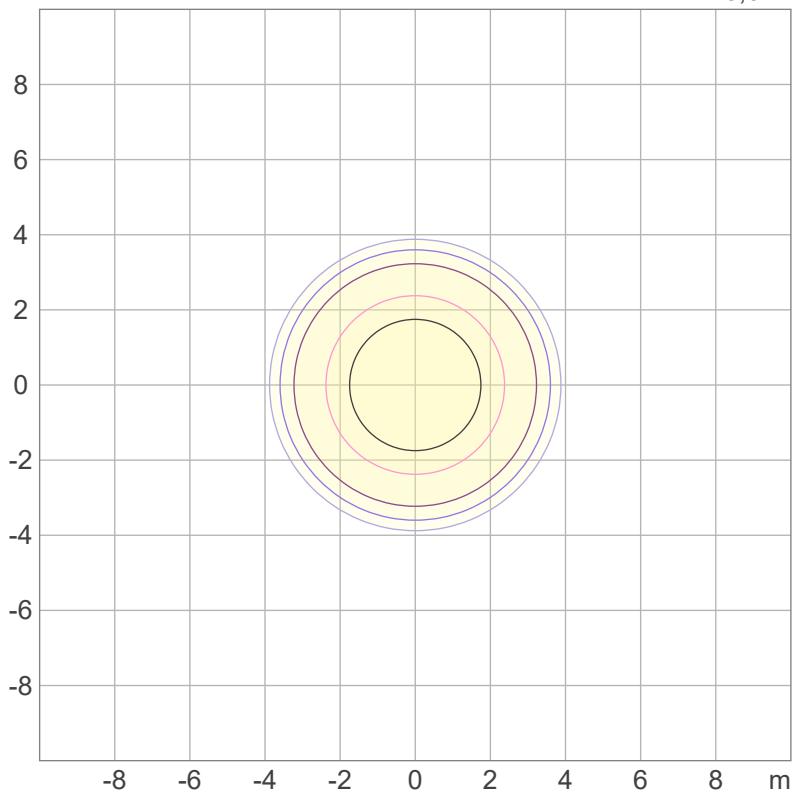

Mounting height: 10 meters (33 feet)

3%	0,267 lx
5%	0,445 lx
10%	0,890 lx
30%	2,67 lx
50%	4,45 lx

Conditions:

Number of c-planes: 2  
Lux at center: 8,90 lx

*Lux distribution on a surface when lamp is mounted at 10 meters from the surface.*



Total lumen output:

71,3 lm

Peak candela output:

2003 cd

PRODUCT NAME:

ECLFRCTPS

MEASURAMENT CONDITIONS:

Beam angle:

Min Zoom

Target:

Cyan - HB

Operator:

Salvatore Giglio

Date and time:

02/10/2023 16:35:37

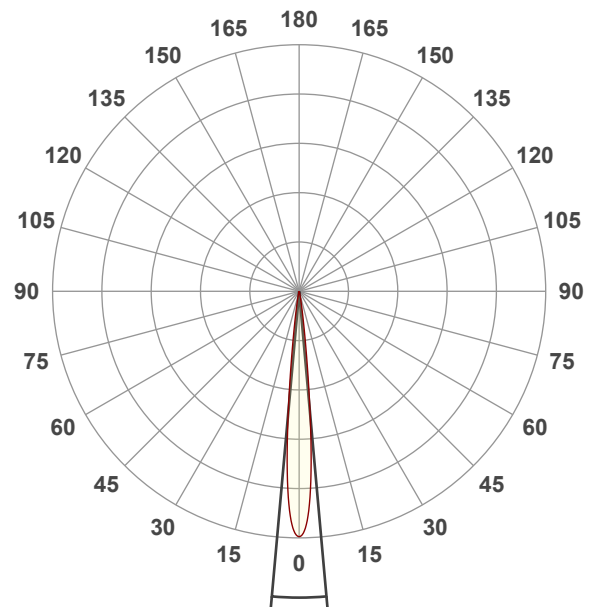

Spectra

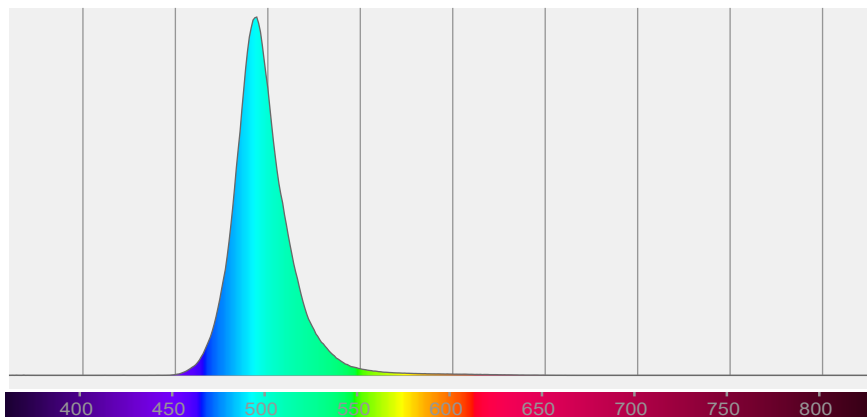

# BEAM DETAILS



Beam angle 50%	Field angle 10%	Cut off angle 2,5%	Intensity ratio in 120° cone	Intensity ratio in 90° cone
10,2°	16,9°	23°	100,0%	100,0%

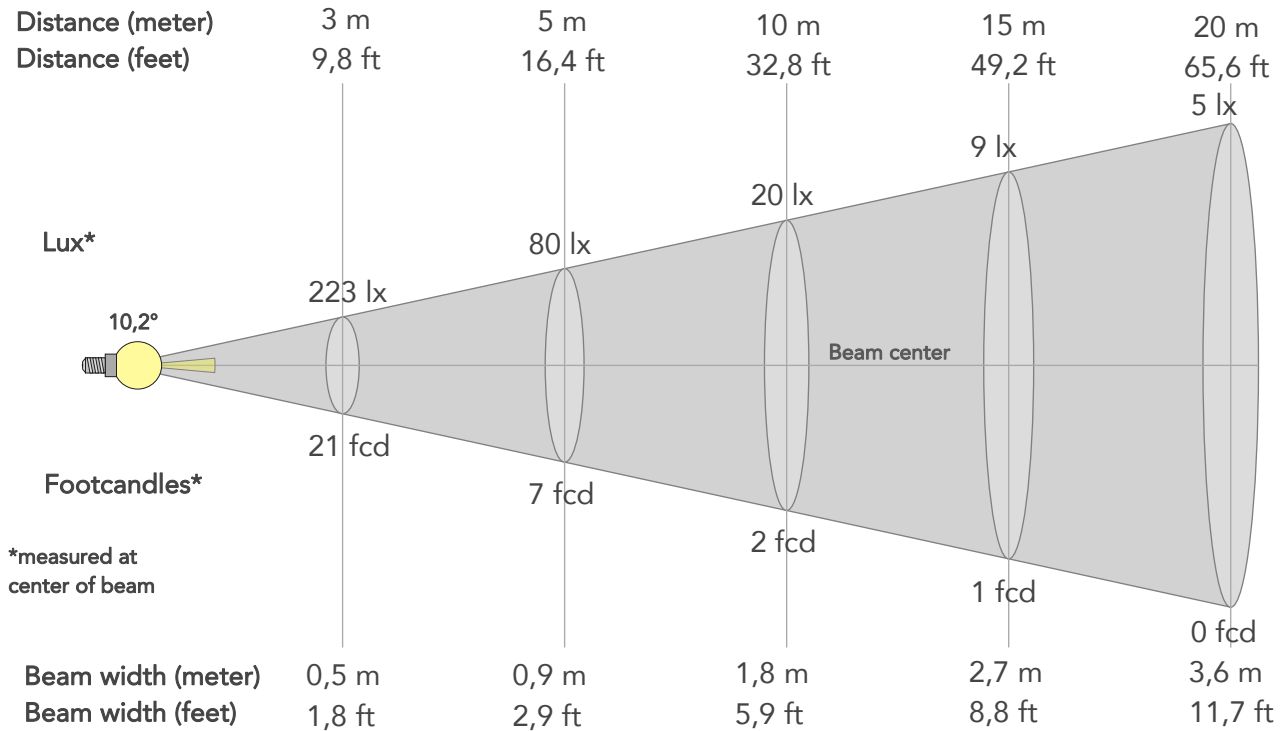

## BEAM INTENSITIES AND WIDTHS

Distance	1m	2m	3m	4m	5m	7,5m	10m	15m	20m	25m	30m	40m	50m
Distance	3,3ft	6,6ft	9,8ft	13,1ft	16,4ft	24,6ft	32,8ft	49,2ft	65,6ft	82ft	98,4ft	131,2ft	164ft
Lux	2003lx	501lx	223lx	125lx	80lx	36lx	20lx	9lx	5lx	3lx	2lx	1lx	1lx
Footcand.	186fcd	47fcd	21fcd	12fcd	7fcd	3fcd	2fcd	1fcd	0fcd	0fcd	0fcd	0fcd	0fcd
Beam wid.	0,2m	0,4m	0,5m	0,7m	0,9m	1,3m	1,8m	2,7m	3,6m	4,5m	5,4m	7,2m	9m
Beam wid.	0,6ft	1,2ft	1,8ft	2,3ft	2,9ft	4,4ft	5,9ft	8,8ft	11,7ft	14,7ft	17,6ft	23,5ft	29,4ft

## LINEAR DISTRIBUTION DIAGRAM

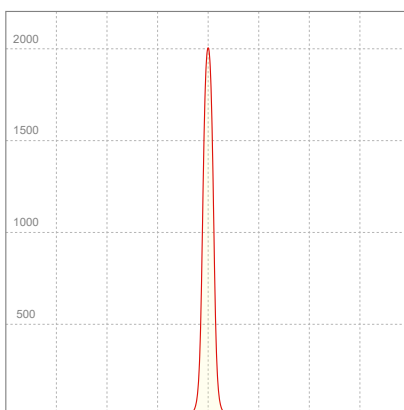

## ELECTRICAL SPECIFICATIONS

Input voltage	Input current	Input power	Effeciency
228V	0,131A	17,1W	4lm/W

Power FC
0,58



## ISO CANDELA DIAGRAM

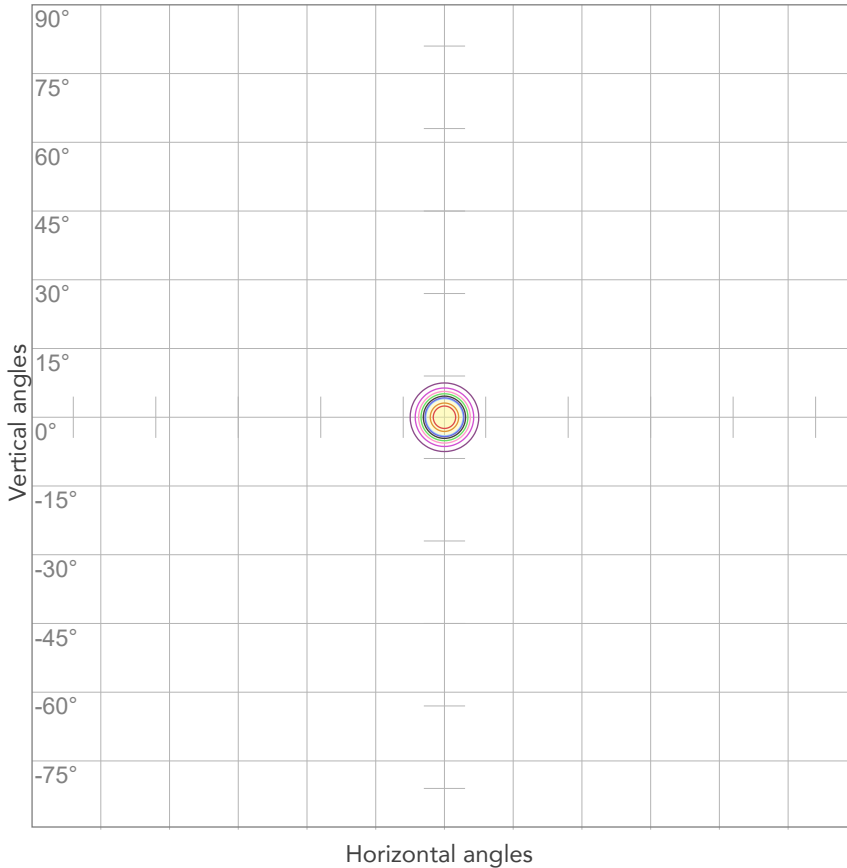

10%	200 cd
20%	401 cd
30%	601 cd
40%	801 cd
50%	1001 cd
60%	1202 cd
70%	1402 cd
80%	1602 cd

Conditions:

Number of c-planes: 2

Candela at center: 2003 cd

## ISO LUX DIAGRAM

MH: 10,0 m

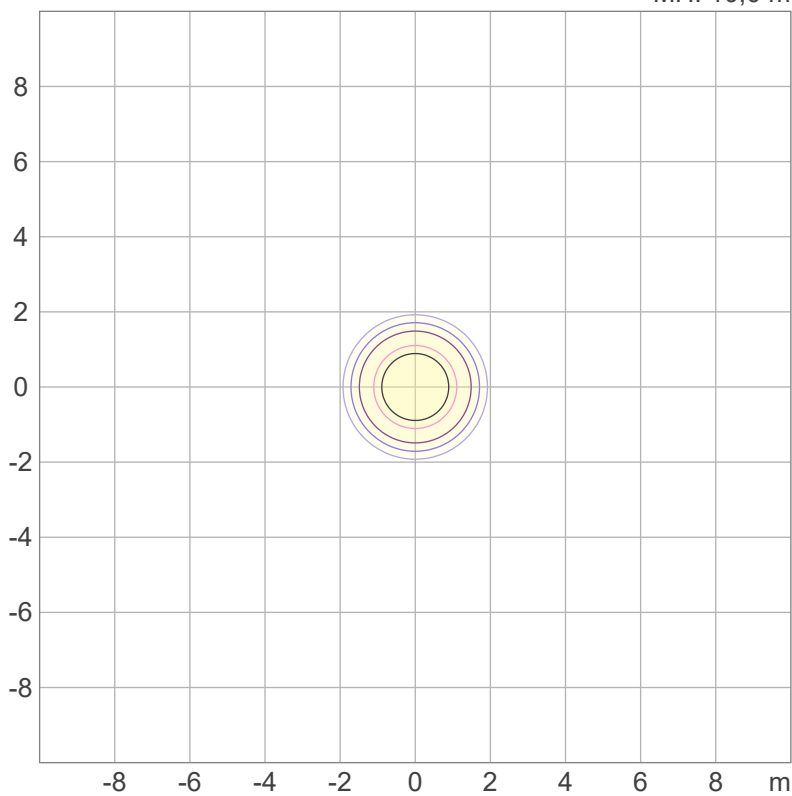

3%	0,601 lx
5%	1,00 lx
10%	2,00 lx
30%	6,01 lx
50%	10,0 lx

Conditions:

Number of c-planes: 2

Lux at center: 20,0 lx

*Lux distribution on a surface when lamp is mounted at 10 meters from the surface.*



Total lumen output:

2810 lm

Peak candela output:

4250 cd

PRODUCT NAME:

ECLFRCTPS

MEASUREMENT CONDITIONS:

Beam angle:

Max Zoom

Target:

Mint - HB

Operator:

Salvatore Giglio

Date and time:

02/10/2023 16:50:05

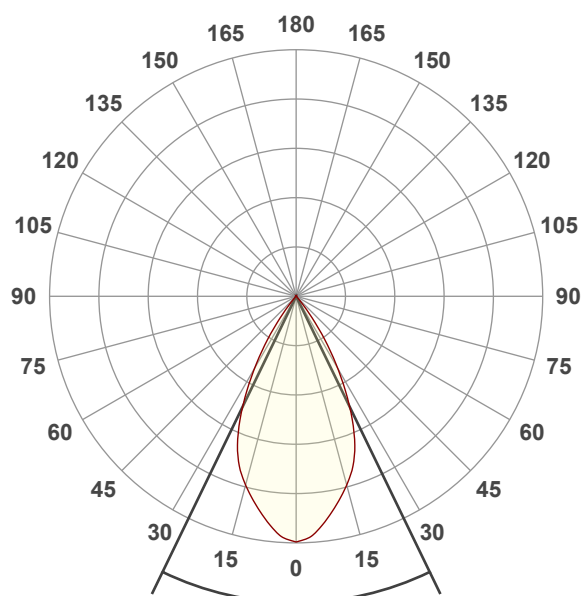

Beam angle 50%: 51,7°

Field angle 10%: 73,9°

Cut off angle 2.5%: 82,2°

Spectra

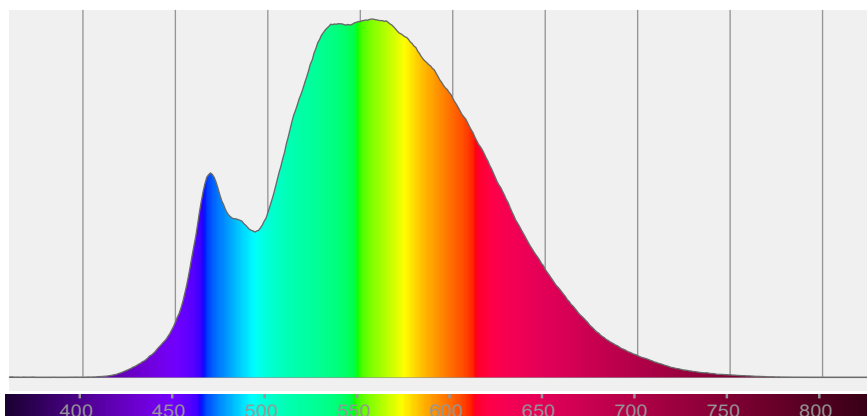

# BEAM DETAILS



Beam angle 50%	Field angle 10%	Cut off angle 2,5%	Intensity ratio in 120° cone	Intensity ratio in 90° cone
51,7°	73,9°	82,2°	100,0%	99,5%

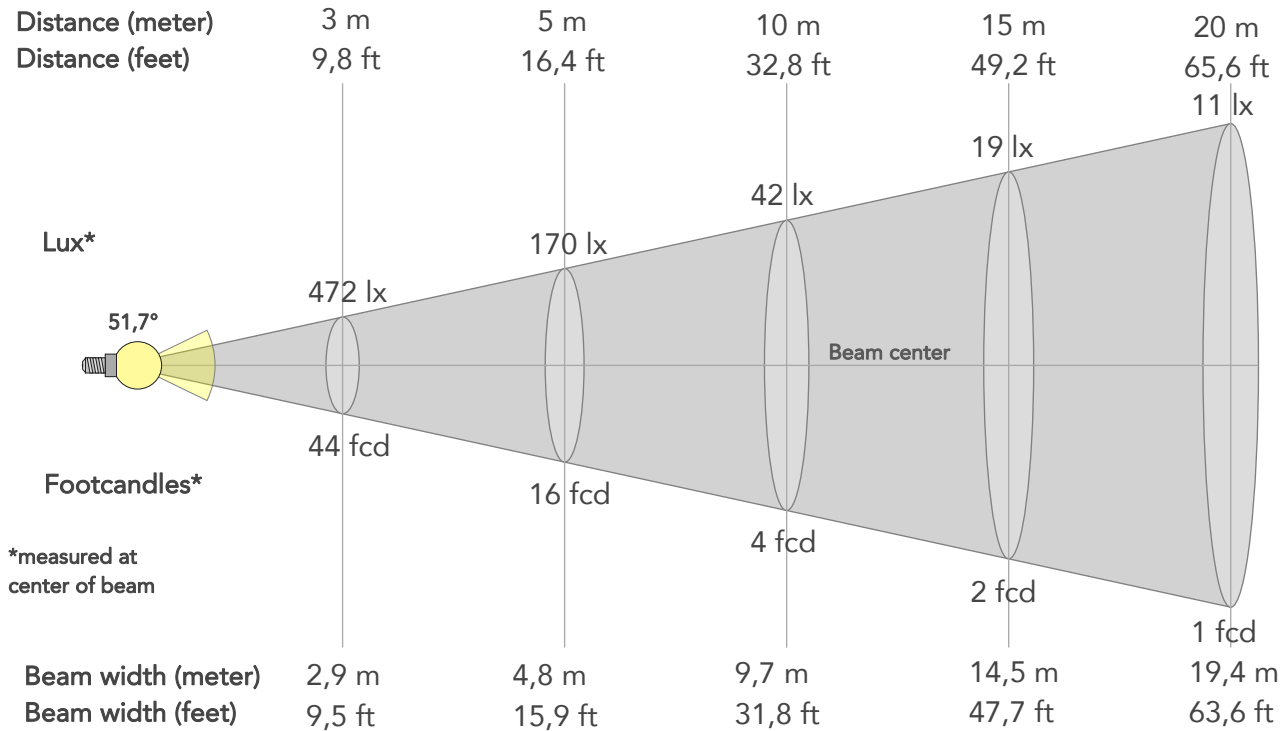

## BEAM INTENSITIES AND WIDTHS

Distance	1m	2m	3m	4m	5m	7,5m	10m	15m	20m	25m	30m	40m	50m
Distance	3,3ft	6,6ft	9,8ft	13,1ft	16,4ft	24,6ft	32,8ft	49,2ft	65,6ft	82ft	98,4ft	131,2ft	164ft
Lux	4250lx	1062lx	472lx	266lx	170lx	76lx	42lx	19lx	11lx	7lx	5lx	3lx	2lx
Footcand.	395fcd	99fcd	44fcd	25fcd	16fcd	7fcd	4fcd	2fcd	1fcd	1fcd	0fcd	0fcd	0fcd
Beam wid.	1m	1,9m	2,9m	3,9m	4,8m	7,3m	9,7m	14,5m	19,4m	24,2m	29,1m	38,8m	48,5m
Beam wid.	3,2ft	6,4ft	9,5ft	12,7ft	15,9ft	23,8ft	31,8ft	47,7ft	63,6ft	79,5ft	95,4ft	127,2ft	158,9ft

## LINEAR DISTRIBUTION DIAGRAM

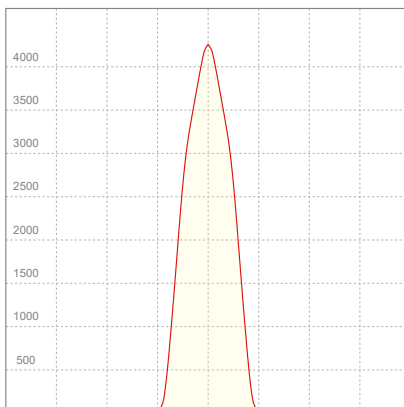

## ELECTRICAL SPECIFICATIONS

Input voltage	Input current	Input power	Effeciency
227V	0,337A	74,2W	38lm/W

Power FC
0,97

## ISO CANDELA DIAGRAM

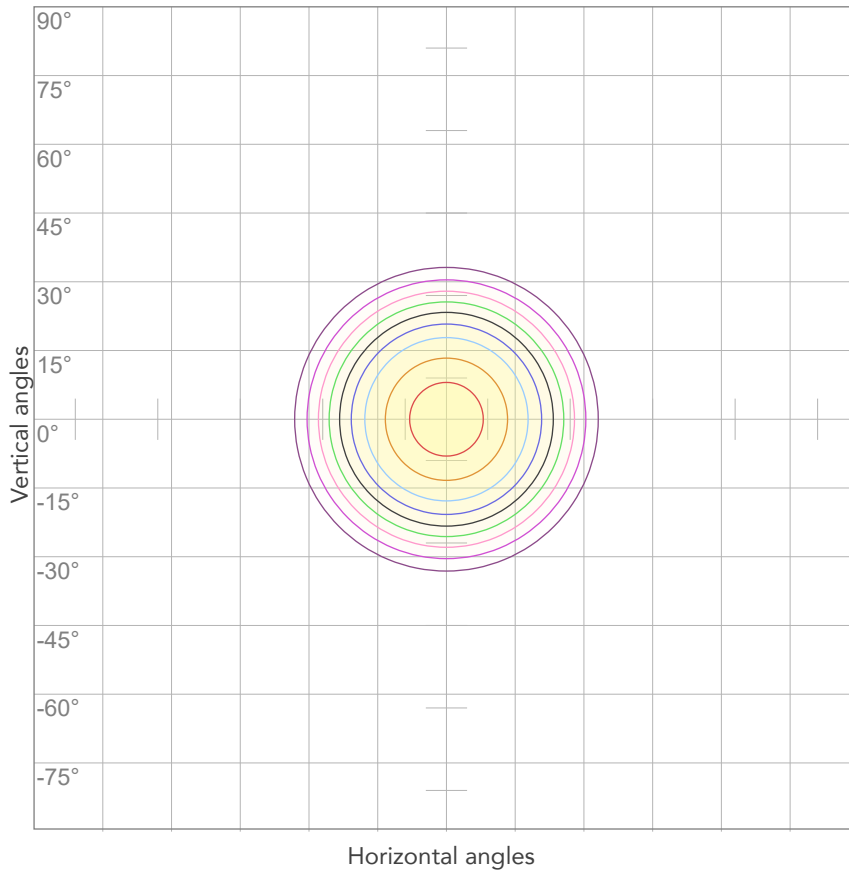

10%	425 cd
20%	850 cd
30%	1275 cd
40%	1700 cd
50%	2125 cd
60%	2550 cd
70%	2975 cd
80%	3400 cd

**Conditions:**

Number of c-planes: 2

Candela at center: 4250 cd

## ISO LUX DIAGRAM

MH: 10,0 m

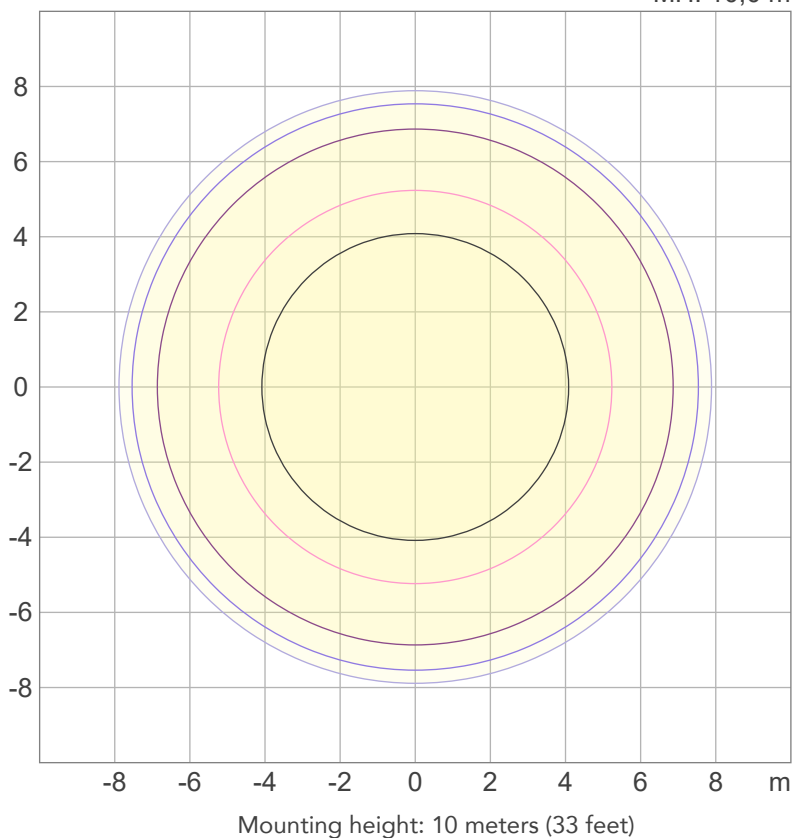

3%	1,27 lx
5%	2,12 lx
10%	4,25 lx
30%	12,7 lx
50%	21,2 lx

**Conditions:**

Number of c-planes: 2

Lux at center: 42,5 lx

*Lux distribution on a surface when lamp is mounted at 10 meters from the surface.*



Total lumen output:

2095 lm

Peak candela output:

14342 cd

**PRODUCT NAME:**

ECLFRCTPS

**MEASUREMENT CONDITIONS:**

Beam angle:

Med Zoom

Target:

Mint - HB

Operator:

Salvatore Giglio

Date and time:

02/10/2023 17:26:46

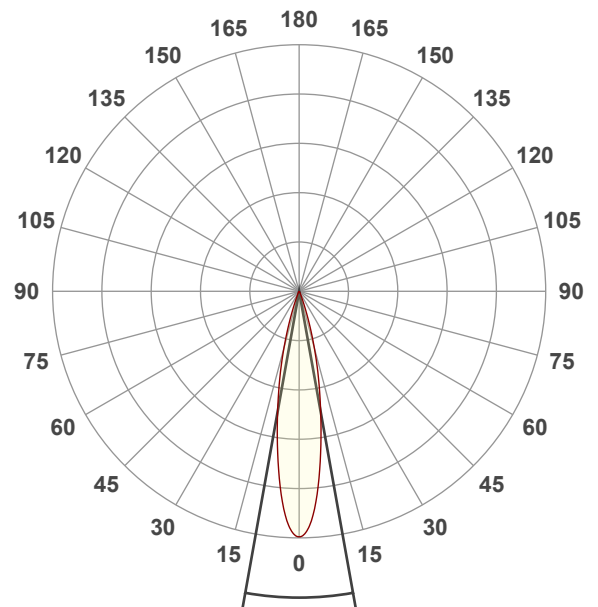

Beam angle 50%: 20,3°

Field angle 10%: 37°

Cut off angle 2.5%: 45,8°

Spectra

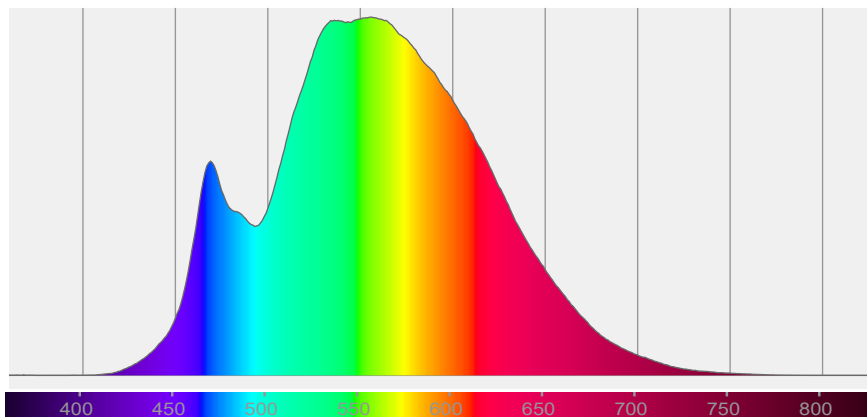

# BEAM DETAILS



Beam angle 50%	Field angle 10%	Cut off angle 2,5%	Intensity ratio in 120° cone	Intensity ratio in 90° cone
20,3°	37°	45,8°	100,0%	99,9%

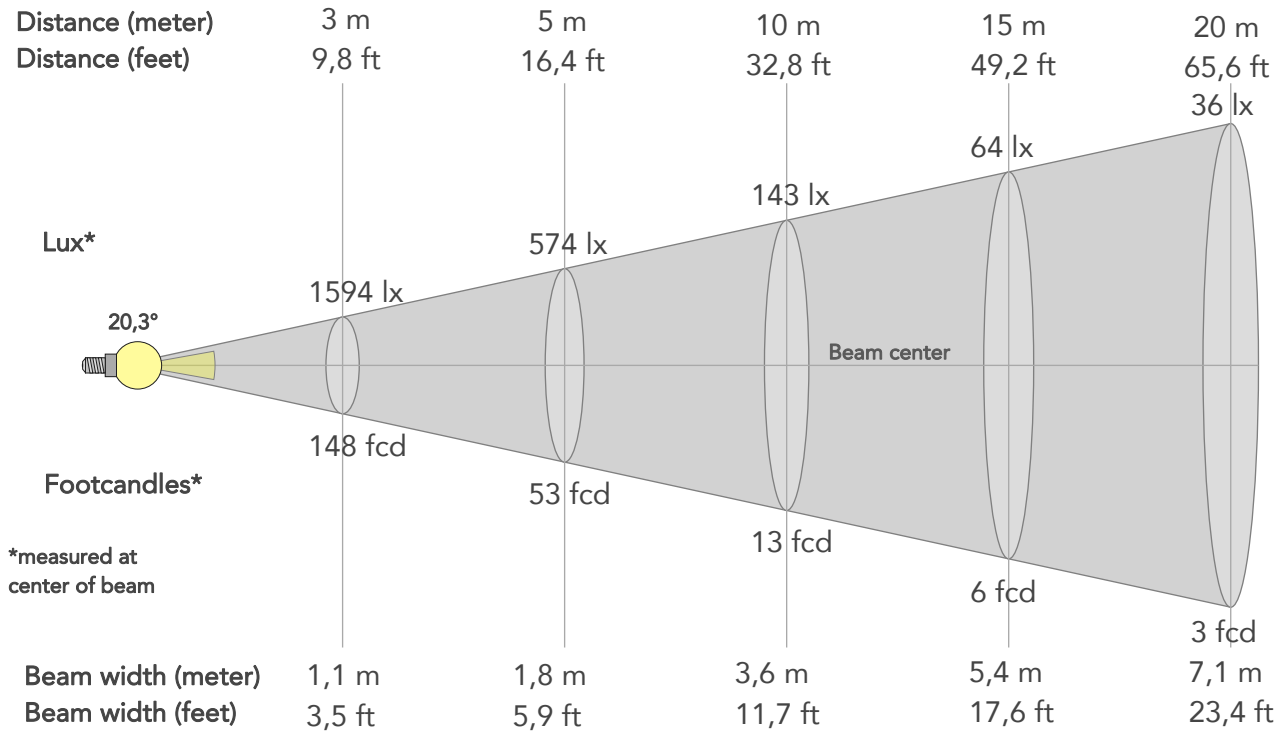

## BEAM INTENSITIES AND WIDTHS

Distance	1m	2m	3m	4m	5m	7,5m	10m	15m	20m	25m	30m	40m	50m
Distance	3,3ft	6,6ft	9,8ft	13,1ft	16,4ft	24,6ft	32,8ft	49,2ft	65,6ft	82ft	98,4ft	131,2ft	164ft
Lux	14342lx	3585lx	1594lx	896lx	574lx	255lx	143lx	64lx	36lx	23lx	16lx	9lx	6lx
Footcand.	1332fcd	333fcd	148fcd	83fcd	53fcd	24fcd	13fcd	6fcd	3fcd	2fcd	1fcd	1fcd	1fcd
Beam wid.	0,4m	0,7m	1,1m	1,4m	1,8m	2,7m	3,6m	5,4m	7,1m	8,9m	10,7m	14,3m	17,9m
Beam wid.	1,2ft	2,4ft	3,5ft	4,7ft	5,9ft	8,8ft	11,7ft	17,6ft	23,4ft	29,3ft	35,2ft	46,9ft	58,6ft

## LINEAR DISTRIBUTION DIAGRAM

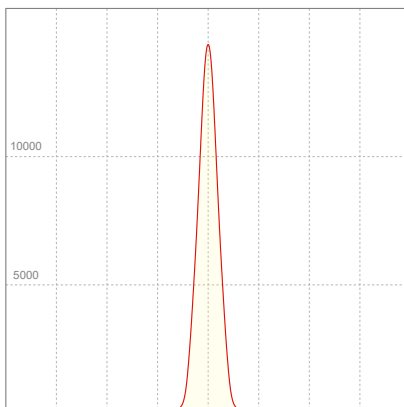

## ELECTRICAL SPECIFICATIONS

Input voltage	Input current	Input power	Effeciency
226V	0,339A	74,3W	28lm/W

Power FC
0,97

## ISO CANDELA DIAGRAM

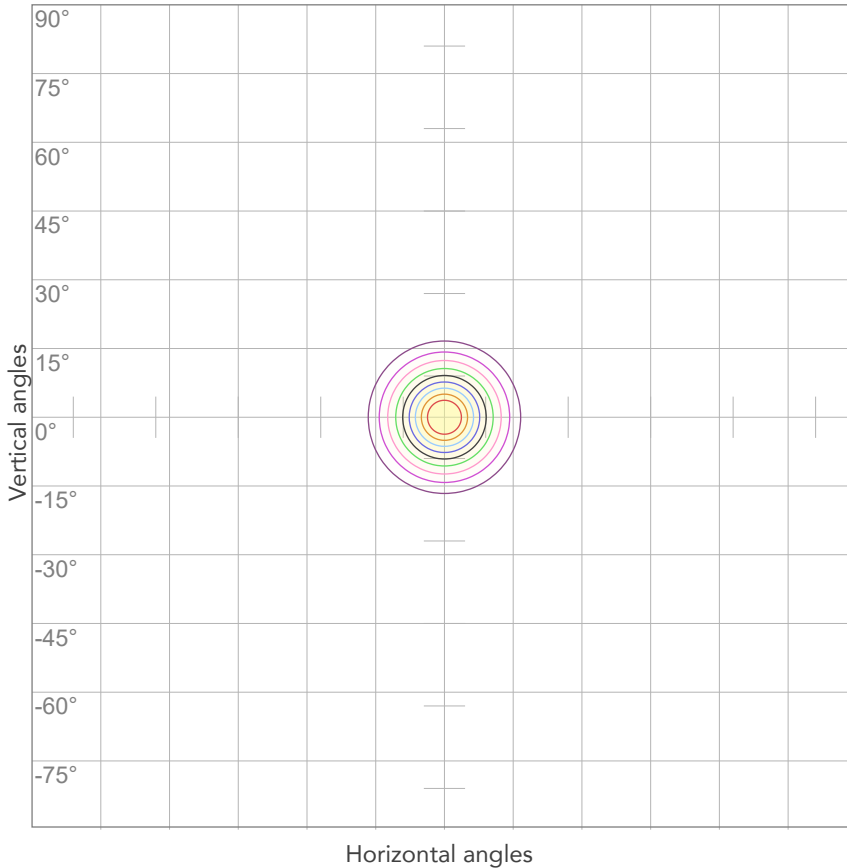

10%	1434 cd
20%	2868 cd
30%	4303 cd
40%	5737 cd
50%	7171 cd
60%	8605 cd
70%	10039 cd
80%	11474 cd

Conditions:

Number of c-planes: 2

Candela at center: 14342 cd

## ISO LUX DIAGRAM

MH: 10,0 m

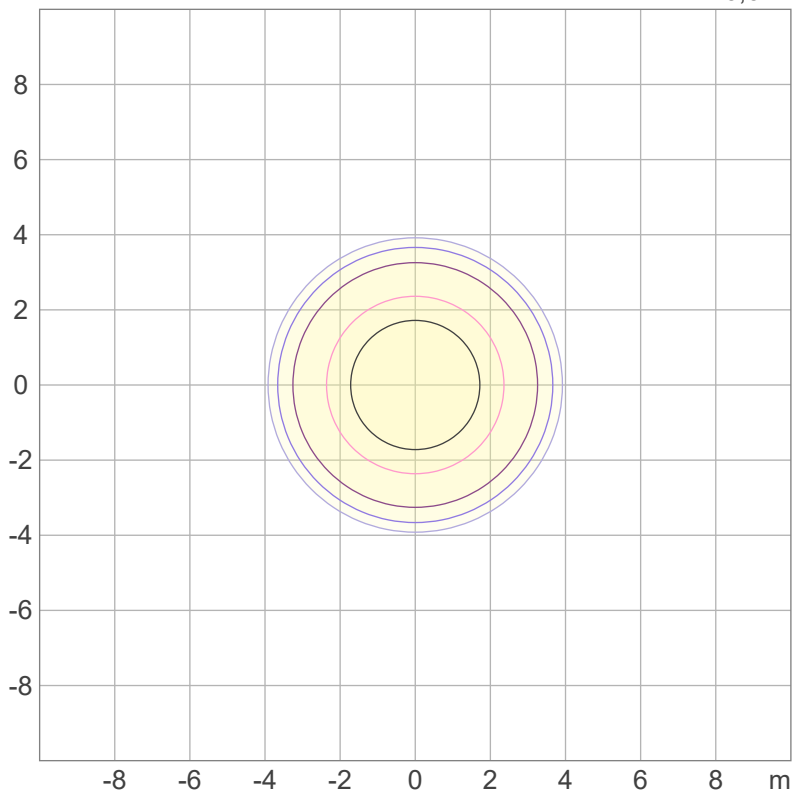

Mounting height: 10 meters (33 feet)

3%	4,30 lx
5%	7,17 lx
10%	14,3 lx
30%	43,0 lx
50%	71,7 lx

Conditions:

Number of c-planes: 2

Lux at center: 143 lx

*Lux distribution on a surface when lamp is mounted at 10 meters from the surface.*



Total lumen output:

1206 lm

Peak candela output:

33208 cd

**PRODUCT NAME:**

ECLFRCTPS

**MEASURAMENT CONDITIONS:**

Beam angle:

Min Zoom

Target:

Mint - HB

Operator:

Salvatore Giglio

Date and time:

02/10/2023 16:40:50

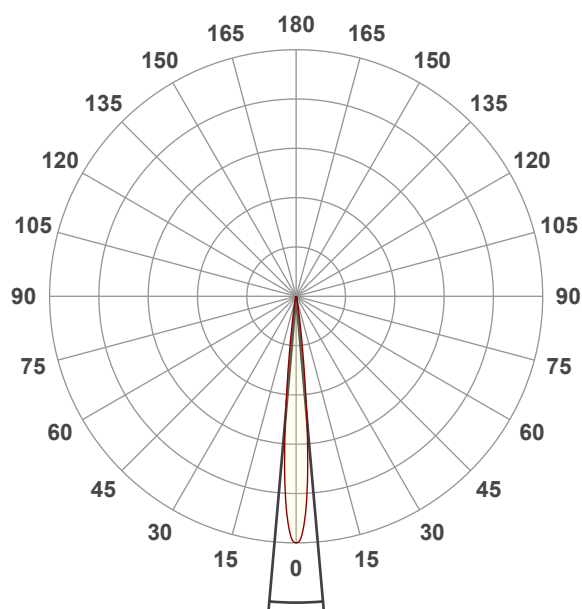

Beam angle 50%: 10°

Field angle 10%: 17,1°

Cut off angle 2.5%: 23,8°

Spectra

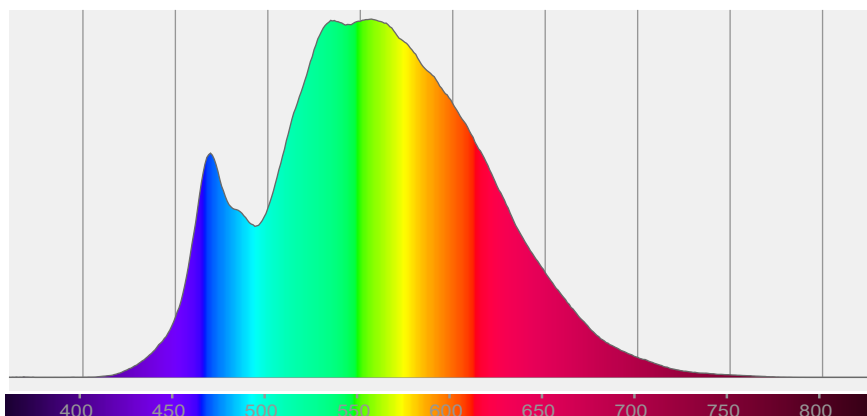



# BEAM DETAILS



Beam angle 50%	Field angle 10%	Cut off angle 2,5%	Intensity ratio in 120° cone	Intensity ratio in 90° cone
10°	17,1°	23,8°	100,0%	100,0%

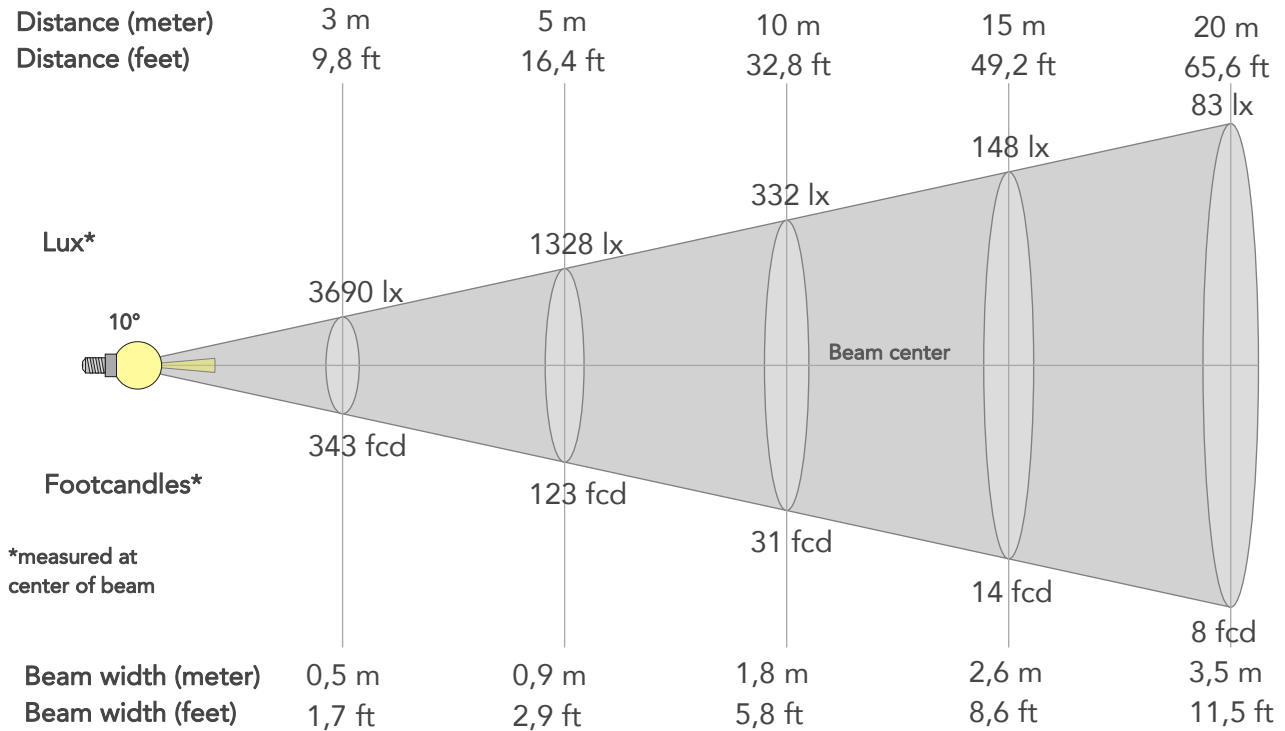

## BEAM INTENSITIES AND WIDTHS

Distance	1m	2m	3m	4m	5m	7,5m	10m	15m	20m	25m	30m	40m	50m
Distance	3,3ft	6,6ft	9,8ft	13,1ft	16,4ft	24,6ft	32,8ft	49,2ft	65,6ft	82ft	98,4ft	131,2ft	164ft
Lux	33208lx	8302lx	3690lx	2076lx	1328lx	590lx	332lx	148lx	83lx	53lx	37lx	21lx	13lx
Footcand.	3085fcd	771fcd	343fcd	193fcd	123fcd	55fcd	31fcd	14fcd	8fcd	5fcd	3fcd	2fcd	1fcd
Beam wid.	0,2m	0,4m	0,5m	0,7m	0,9m	1,3m	1,8m	2,6m	3,5m	4,4m	5,3m	7m	8,8m
Beam wid.	0,6ft	1,2ft	1,7ft	2,3ft	2,9ft	4,3ft	5,8ft	8,6ft	11,5ft	14,4ft	17,3ft	23,1ft	28,8ft

## LINEAR DISTRIBUTION DIAGRAM

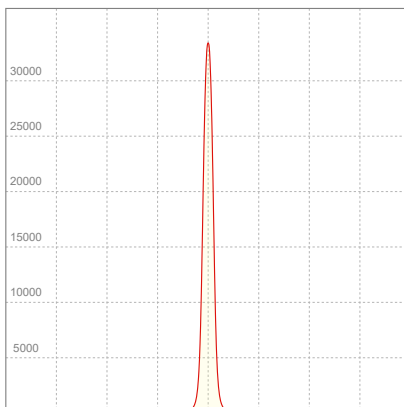

## ELECTRICAL SPECIFICATIONS

Input voltage	Input current	Input power	Effeciency
227V	0,336A	74,2W	16lm/W

Power FC
0,97

## ISO CANDELA DIAGRAM

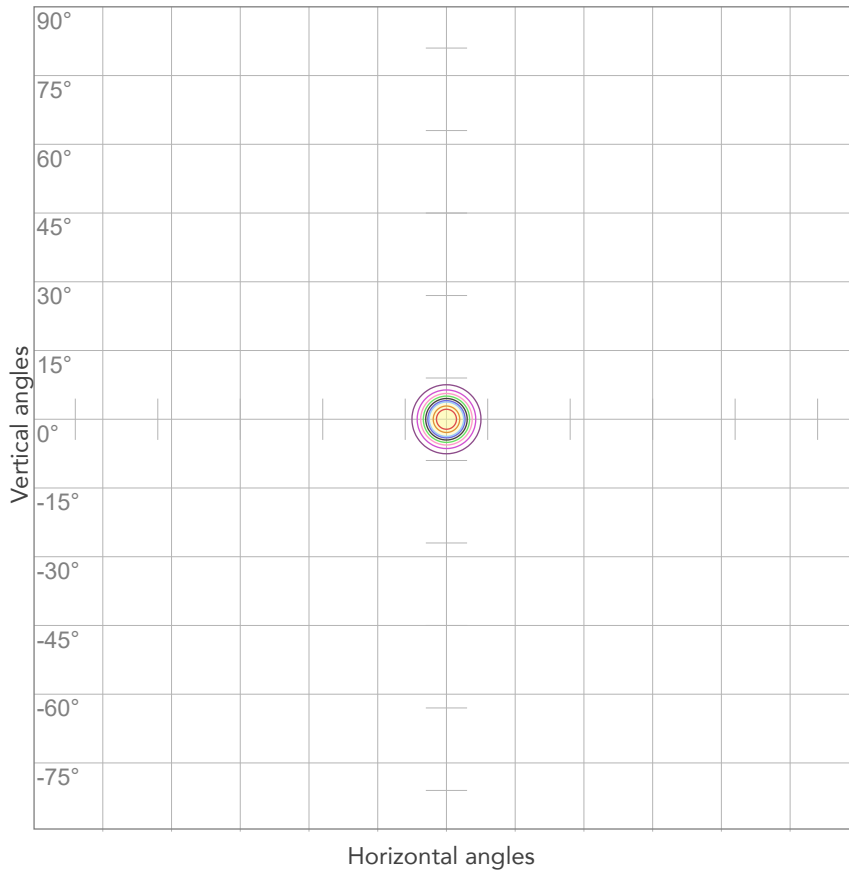

10%	3321 cd
20%	6642 cd
30%	9963 cd
40%	13283 cd
50%	16604 cd
60%	19925 cd
70%	23246 cd
80%	26567 cd

Conditions:

Number of c-planes: 2

Candela at center: 33208 cd

## ISO LUX DIAGRAM

MH: 10,0 m

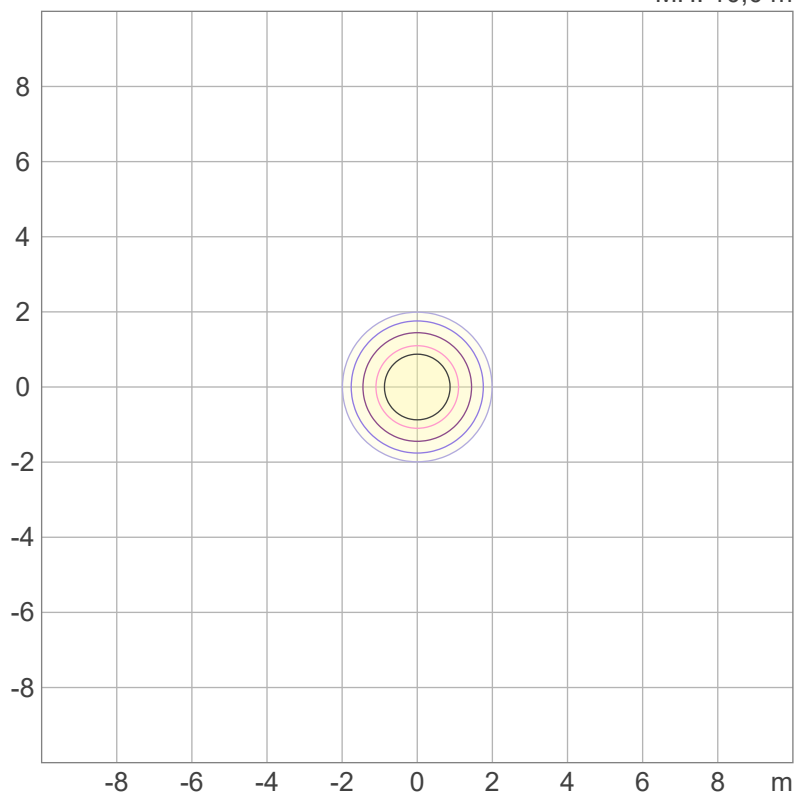

3%	9,96 lx
5%	16,6 lx
10%	33,2 lx
30%	99,6 lx
50%	166 lx

Conditions:

Number of c-planes: 2

Lux at center: 332 lx

*Lux distribution on a surface when lamp is mounted at 10 meters from the surface.*



Total lumen output:

1554 lm

Peak candela output:

2334 cd

PRODUCT NAME:

ECLFRCTPS

MEASURAMENT CONDITIONS:

Beam angle:

Max Zoom

Target:

Amber - HB

Operator:

Salvatore Giglio

Date and time:

02/10/2023 16:51:30

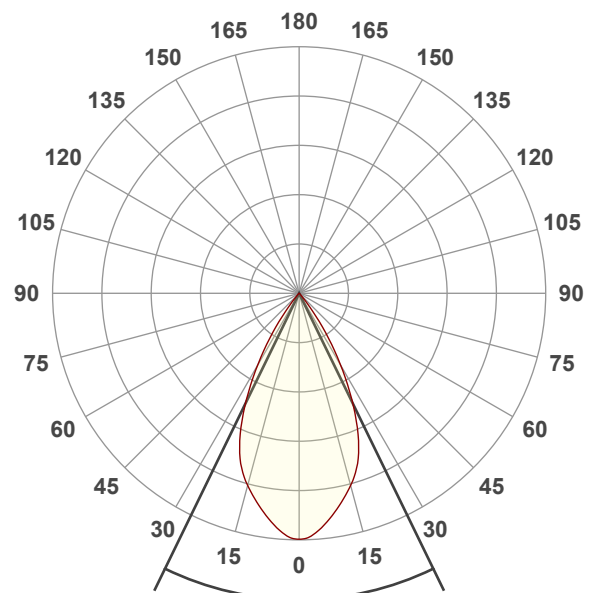

Beam angle 50%: 51,9°

Field angle 10%: 73,7°

Cut off angle 2.5%: 81°

Spectra

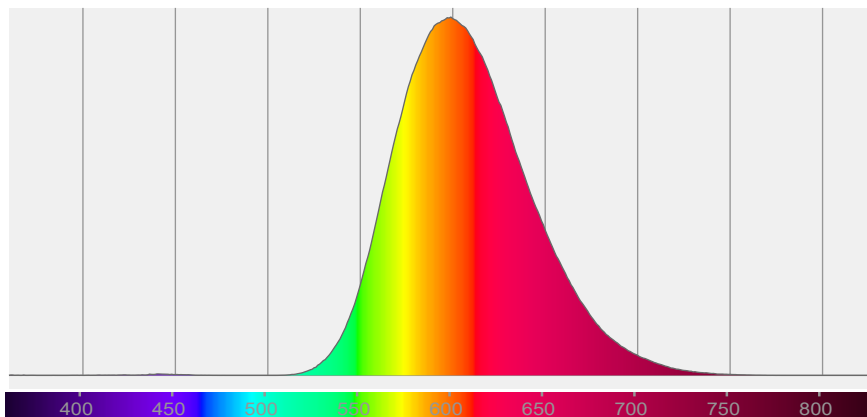

# BEAM DETAILS



Beam angle 50%	Field angle 10%	Cut off angle 2,5%	Intensity ratio in 120° cone	Intensity ratio in 90° cone
51,9°	73,7°	81°	100,0%	99,5%

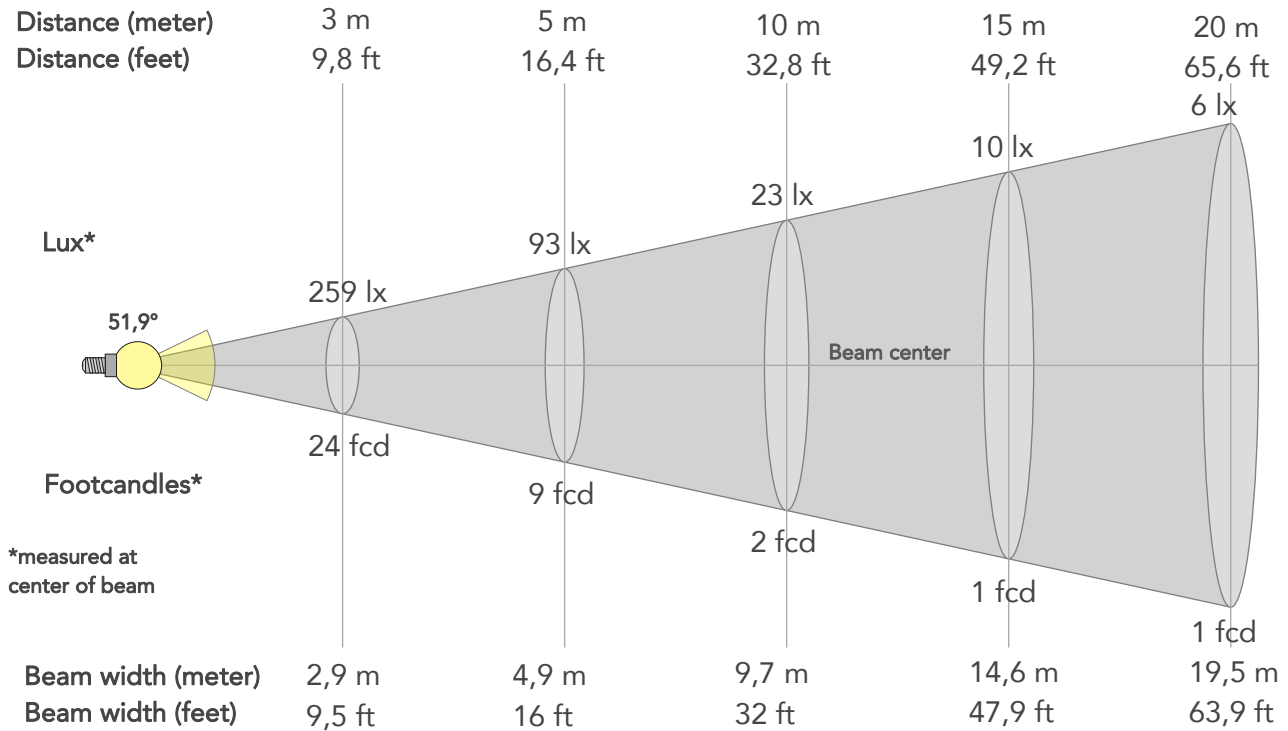

## BEAM INTENSITIES AND WIDTHS

Distance	1m	2m	3m	4m	5m	7,5m	10m	15m	20m	25m	30m	40m	50m
Distance	3,3ft	6,6ft	9,8ft	13,1ft	16,4ft	24,6ft	32,8ft	49,2ft	65,6ft	82ft	98,4ft	131,2ft	164ft
Lux	2334lx	584lx	259lx	146lx	93lx	41lx	23lx	10lx	6lx	4lx	3lx	1lx	1lx
Footcand.	217fcd	54fcd	24fcd	14fcd	9fcd	4fcd	2fcd	1fcd	1fcd	0fcd	0fcd	0fcd	0fcd
Beam wid.	1m	1,9m	2,9m	3,9m	4,9m	7,3m	9,7m	14,6m	19,5m	24,4m	29,2m	39m	48,7m
Beam wid.	3,2ft	6,4ft	9,5ft	12,8ft	16ft	24ft	32ft	47,9ft	63,9ft	79,9ft	95,9ft	127,8ft	159,8ft

## LINEAR DISTRIBUTION DIAGRAM

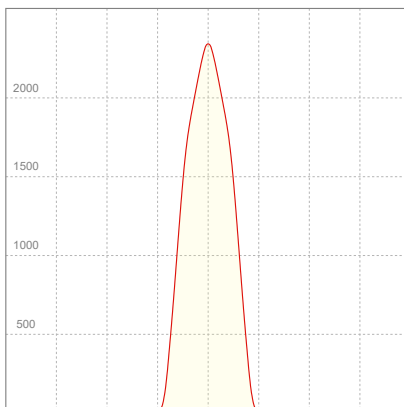

## ELECTRICAL SPECIFICATIONS

Input voltage	Input current	Input power	Effeciency
227V	0,350A	77,5W	20lm/W

Power FC
0,97

## ISO CANDELA DIAGRAM

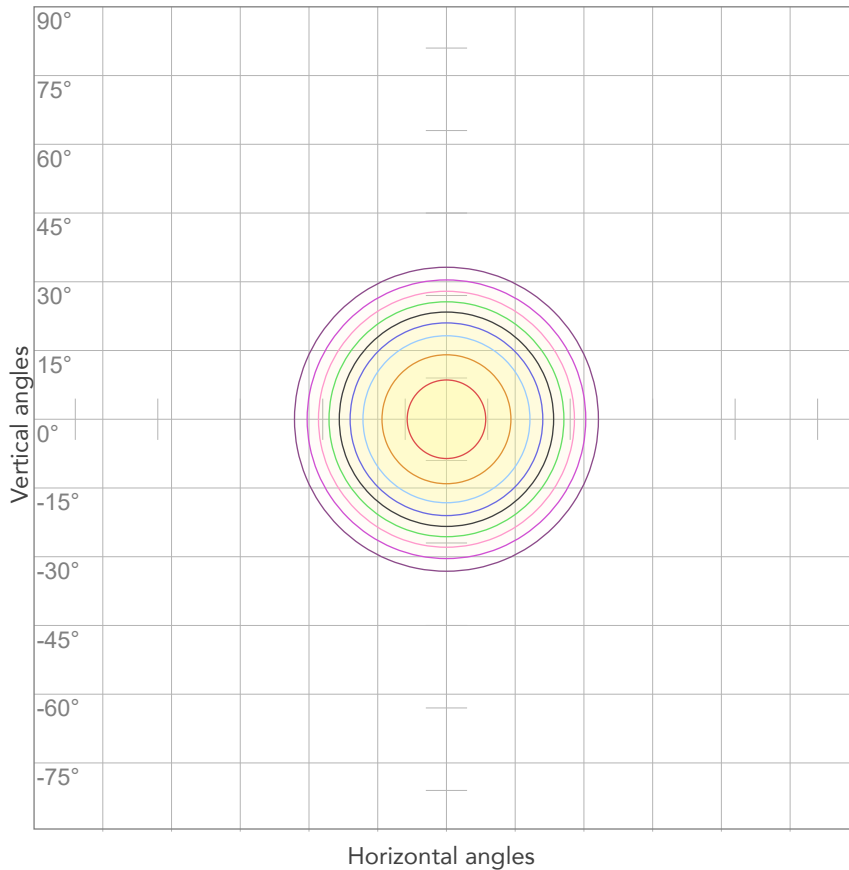

10%	233 cd
20%	467 cd
30%	700 cd
40%	934 cd
50%	1167 cd
60%	1400 cd
70%	1634 cd
80%	1867 cd

Conditions:

Number of c-planes: 2

Candela at center: 2334 cd

## ISO LUX DIAGRAM

MH: 10,0 m

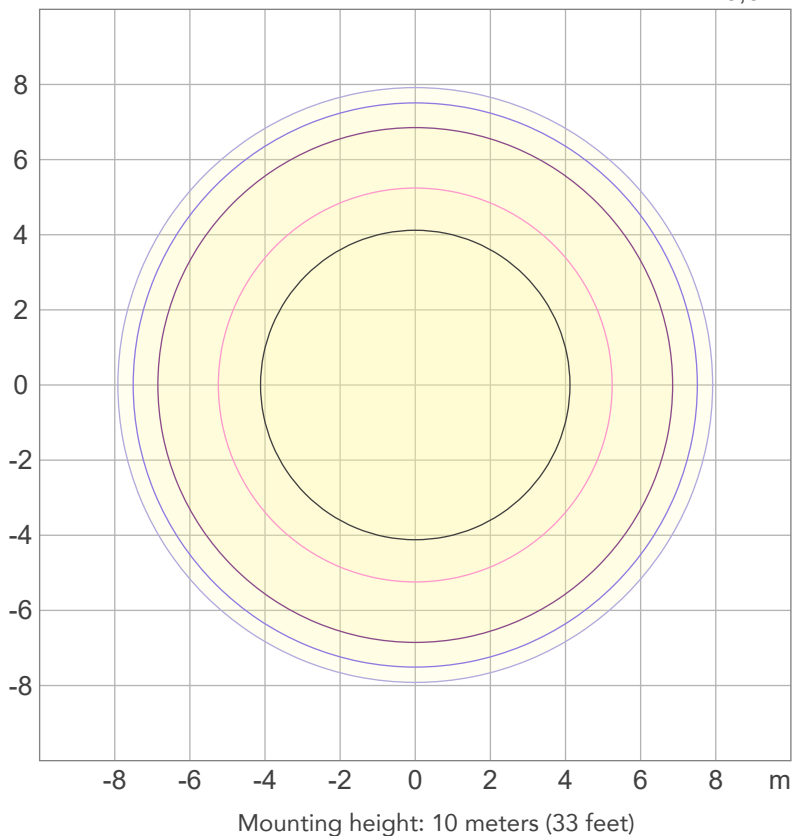

3%	0,700 lx
5%	1,17 lx
10%	2,33 lx
30%	7,00 lx
50%	11,7 lx

Conditions:

Number of c-planes: 2

Lux at center: 23,3 lx

*Lux distribution on a surface when lamp is mounted at 10 meters from the surface.*



Total lumen output:

1152 lm

Peak candela output:

7776 cd

PRODUCT NAME:

ECLFRCTPS

MEASURAMENT CONDITIONS:

Beam angle:

Med Zoom

Target:

Amber - HB

Operator:

Salvatore Giglio

Date and time:

02/10/2023 17:28:14

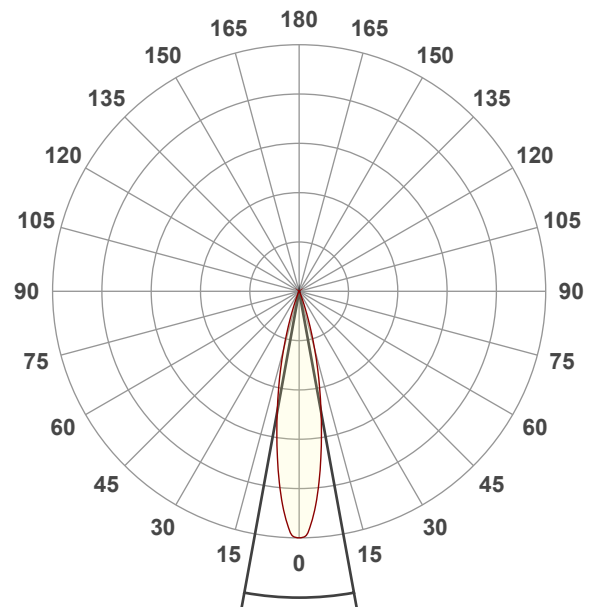

Beam angle 50%: 20,6°

Field angle 10%: 37,3°

Cut off angle 2.5%: 45,8°

Spectra

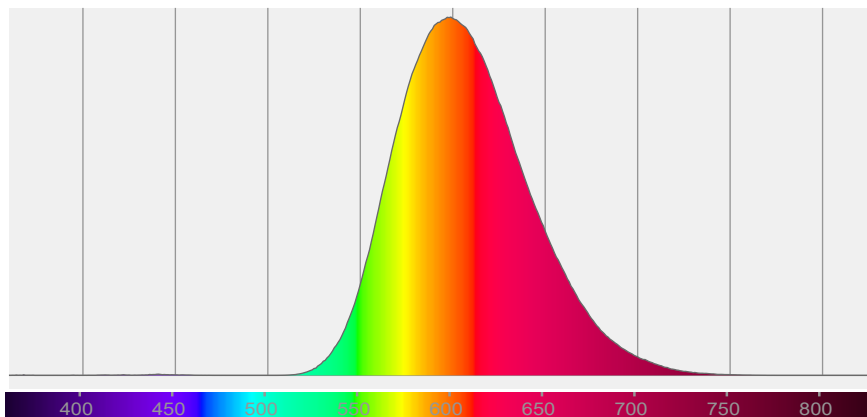

# BEAM DETAILS



Beam angle 50%	Field angle 10%	Cut off angle 2,5%	Intensity ratio in 120° cone	Intensity ratio in 90° cone
20,6°	37,3°	45,8°	100,0%	99,9%

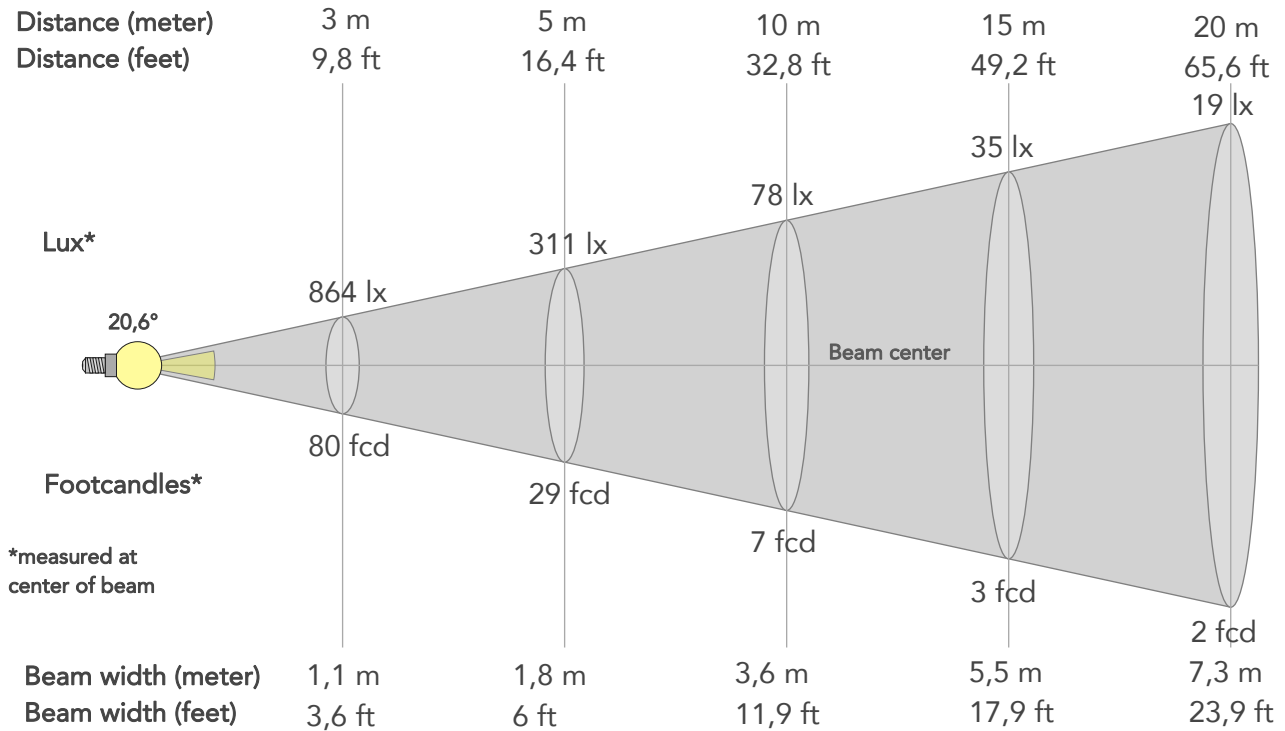

## BEAM INTENSITIES AND WIDTHS

Distance	1m	2m	3m	4m	5m	7,5m	10m	15m	20m	25m	30m	40m	50m
Distance	3,3ft	6,6ft	9,8ft	13,1ft	16,4ft	24,6ft	32,8ft	49,2ft	65,6ft	82ft	98,4ft	131,2ft	164ft
Lux	7776lx	1944lx	864lx	486lx	311lx	138lx	78lx	35lx	19lx	12lx	9lx	5lx	3lx
Footcand.	722fcd	181fcd	80fcd	45fcd	29fcd	13fcd	7fcd	3fcd	2fcd	1fcd	1fcd	0fcd	0fcd
Beam wid.	0,4m	0,7m	1,1m	1,5m	1,8m	2,7m	3,6m	5,5m	7,3m	9,1m	10,9m	14,5m	18,2m
Beam wid.	1,2ft	2,4ft	3,6ft	4,8ft	6ft	8,9ft	11,9ft	17,9ft	23,9ft	29,8ft	35,8ft	47,7ft	59,6ft

## LINEAR DISTRIBUTION DIAGRAM

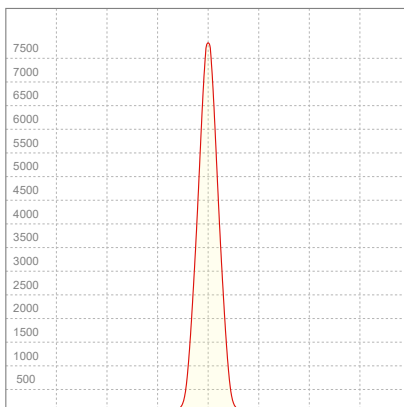

## ELECTRICAL SPECIFICATIONS

Input voltage	Input current	Input power	Effeciency
226V	0,353A	77,7W	15lm/W

Power FC
0,97

## ISO CANDELA DIAGRAM

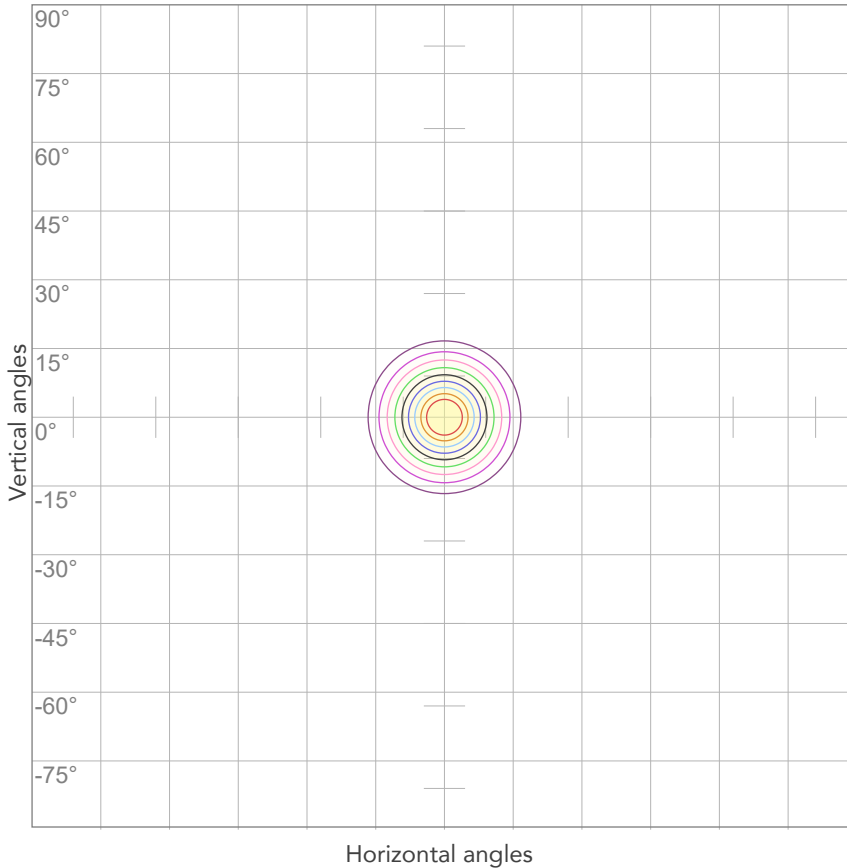

10%	778 cd
20%	1555 cd
30%	2333 cd
40%	3111 cd
50%	3888 cd
60%	4666 cd
70%	5443 cd
80%	6221 cd

Conditions:

Number of c-planes: 2

Candela at center: 7776 cd

## ISO LUX DIAGRAM

MH: 10,0 m

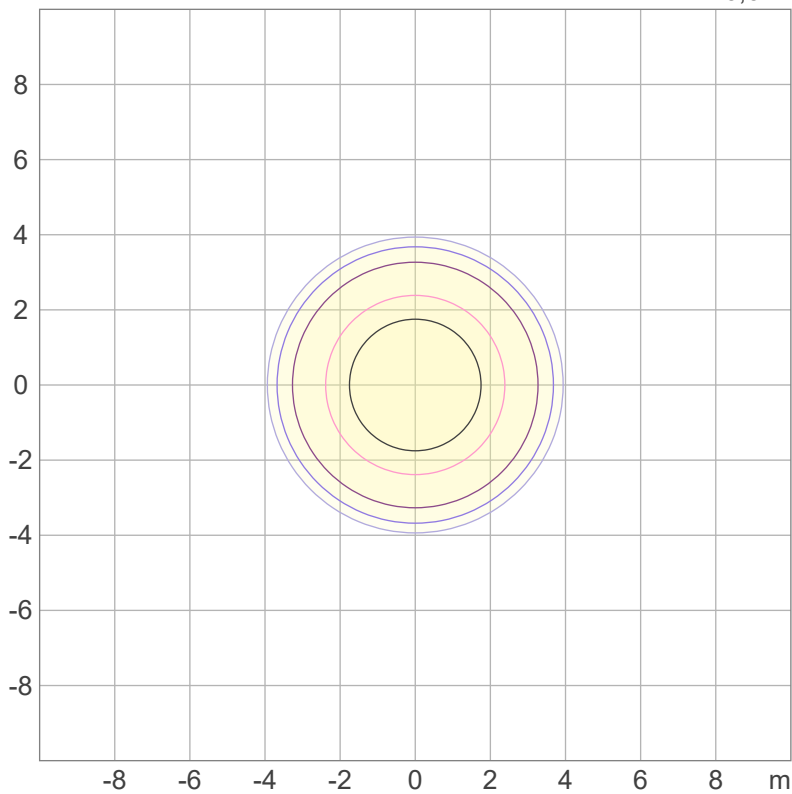

Mounting height: 10 meters (33 feet)

3%	2,33 lx
5%	3,89 lx
10%	7,78 lx
30%	23,3 lx
50%	38,9 lx

Conditions:

Number of c-planes: 2

Lux at center: 77,8 lx

*Lux distribution on a surface when lamp is mounted at 10 meters from the surface.*





Total lumen output:

657 lm

Peak candela output:

18782 cd

PRODUCT NAME:

ECLFRCTPS

MEASURAMENT CONDITIONS:

Beam angle:

Min Zoom

Target:

Amber - HB

Operator:

Salvatore Giglio

Date and time:

02/10/2023 16:42:24

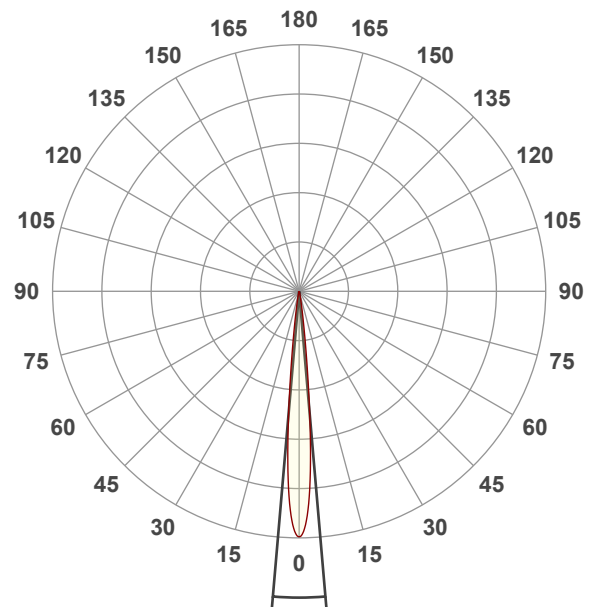

Beam angle 50%: 9,8°

Field angle 10%: 16,7°

Cut off angle 2.5%: 23,3°

Spectra

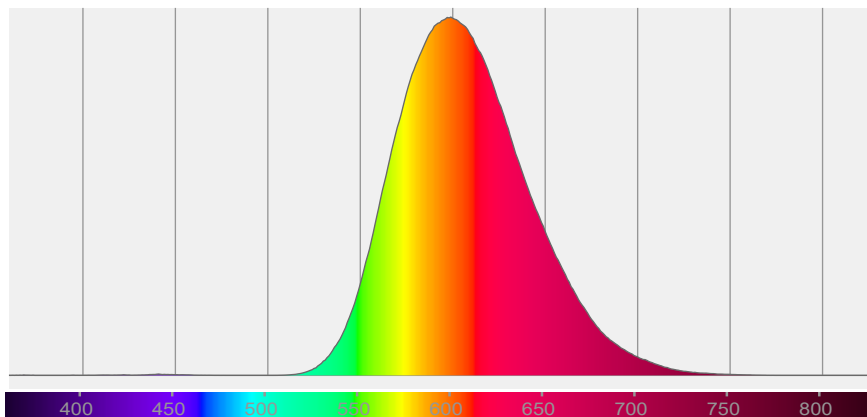

# BEAM DETAILS



Beam angle 50%	Field angle 10%	Cut off angle 2,5%	Intensity ratio in 120° cone	Intensity ratio in 90° cone
9,8°	16,7°	23,3°	100,0%	100,0%

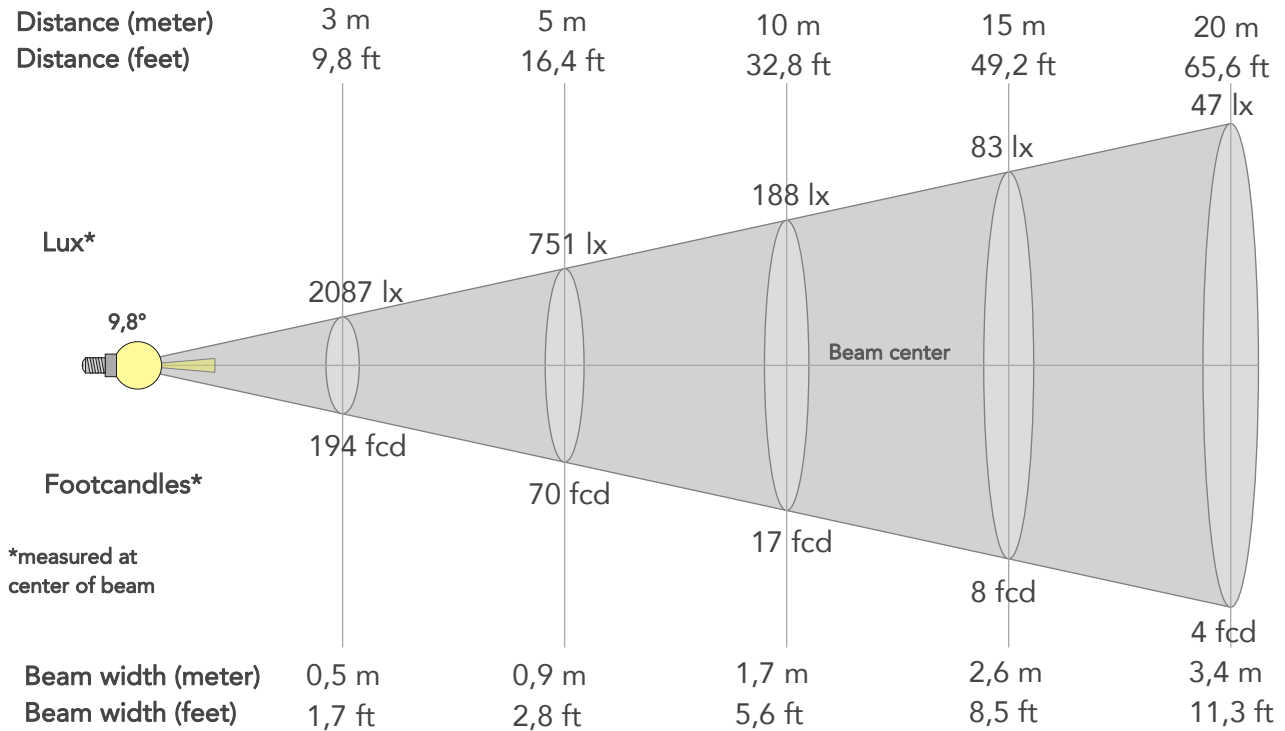

## BEAM INTENSITIES AND WIDTHS

Distance	1m	2m	3m	4m	5m	7,5m	10m	15m	20m	25m	30m	40m	50m
Distance	3,3ft	6,6ft	9,8ft	13,1ft	16,4ft	24,6ft	32,8ft	49,2ft	65,6ft	82ft	98,4ft	131,2ft	164ft
Lux	18782lx	4695lx	2087lx	1174lx	751lx	334lx	188lx	83lx	47lx	30lx	21lx	12lx	8lx
Footcand.	1745fcd	436fcd	194fcd	109fcd	70fcd	31fcd	17fcd	8fcd	4fcd	3fcd	2fcd	1fcd	1fcd
Beam wid.	0,2m	0,3m	0,5m	0,7m	0,9m	1,3m	1,7m	2,6m	3,4m	4,3m	5,2m	6,9m	8,6m
Beam wid.	0,6ft	1,1ft	1,7ft	2,3ft	2,8ft	4,2ft	5,6ft	8,5ft	11,3ft	14,1ft	16,9ft	22,6ft	28,2ft

## LINEAR DISTRIBUTION DIAGRAM

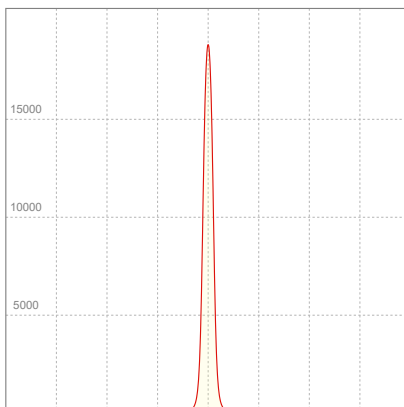

## ELECTRICAL SPECIFICATIONS

Input voltage	Input current	Input power	Effeciency
227V	0,349A	77,2W	9lm/W

Power FC
0,97

## ISO CANDELA DIAGRAM

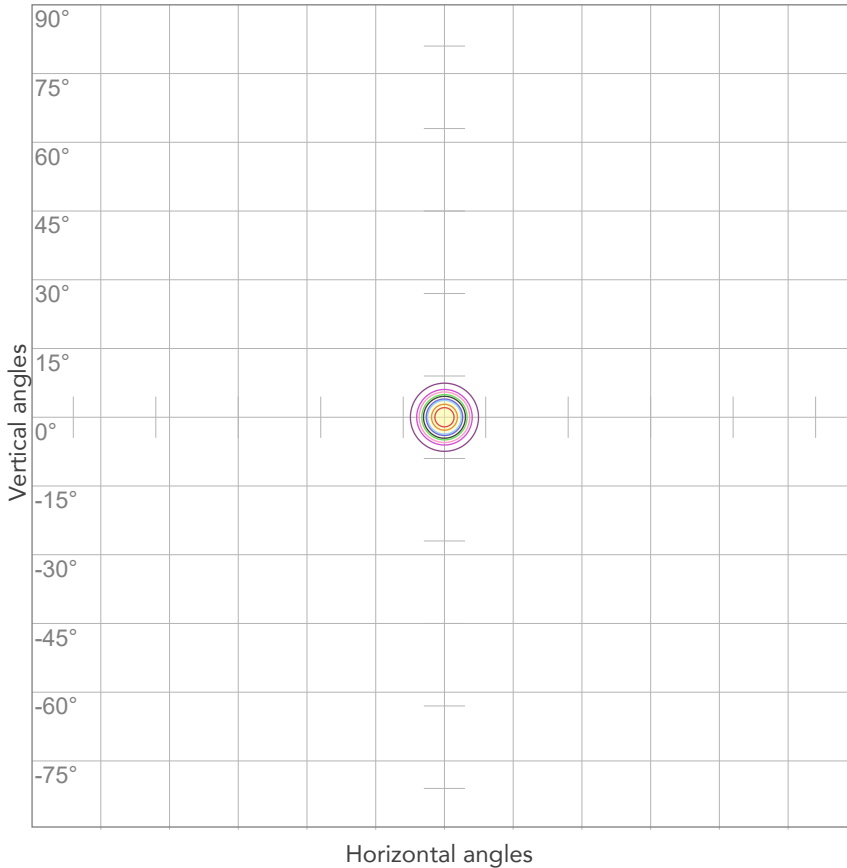

10%	1878 cd
20%	3756 cd
30%	5634 cd
40%	7513 cd
50%	9391 cd
60%	11269 cd
70%	13147 cd
80%	15025 cd

Conditions:

Number of c-planes: 2

Candela at center: 18782 cd

## ISO LUX DIAGRAM

MH: 10,0 m

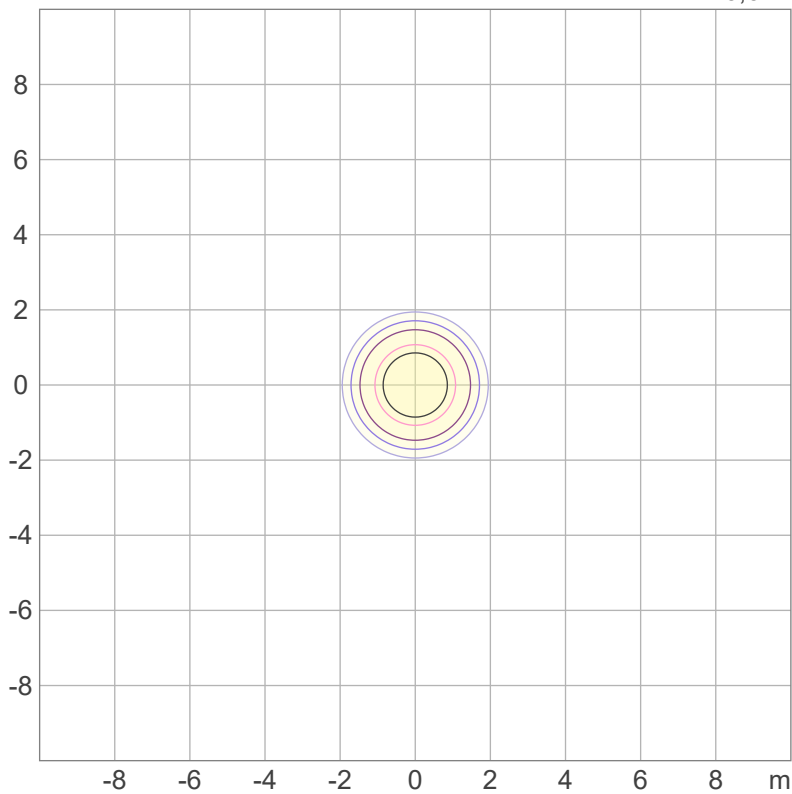

3%	5,63 lx
5%	9,39 lx
10%	18,8 lx
30%	56,3 lx
50%	93,9 lx

Conditions:

Number of c-planes: 2

Lux at center: 188 lx

*Lux distribution on a surface when lamp is mounted at 10 meters from the surface.*



Total lumen output:

4897 lm

Peak candela output:

7406 cd

Light quality:

CRI: 95,7

Color temperature:

2735 K

PRODUCT NAME:

ECLFRCTPS

MEASURAMENT CONDITIONS:

Beam angle:

Max Zoom

Target:

2800K - HB

Operator:

Salvatore Giglio

Date and time:

02/10/2023 16:55:39

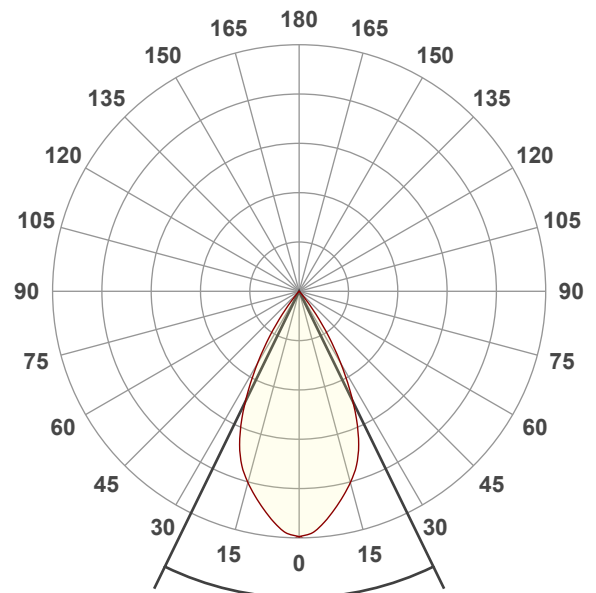

Beam angle 50%: 52°

Field angle 10%: 73,7°

Cut off angle 2.5%: 81,1°

Spectra

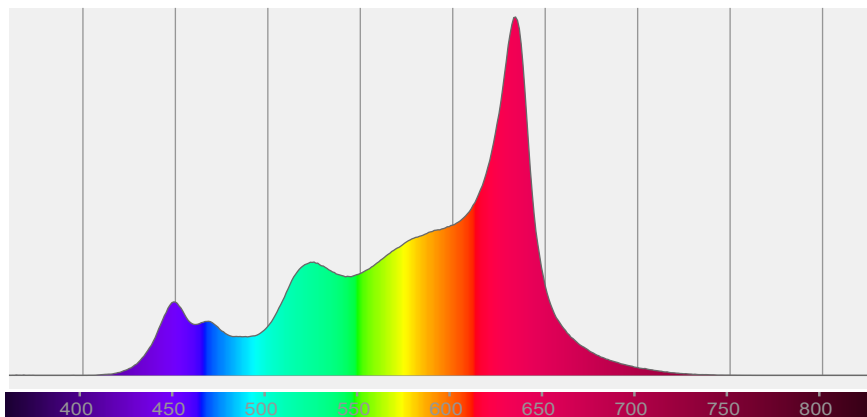

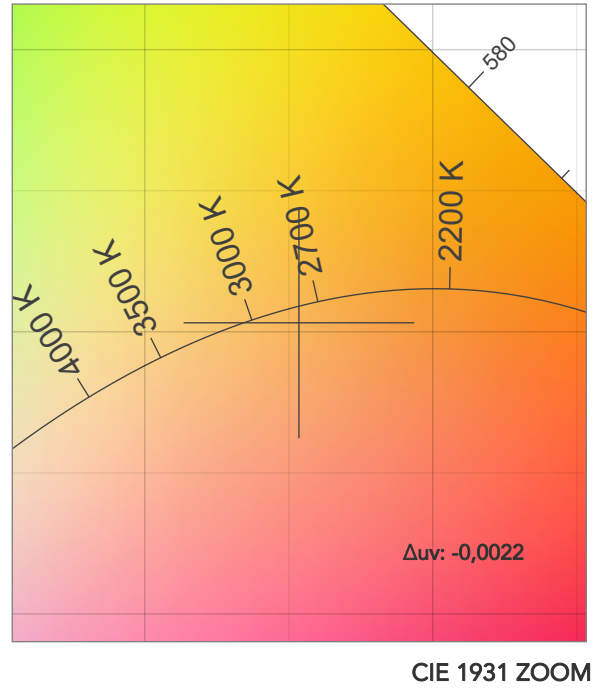
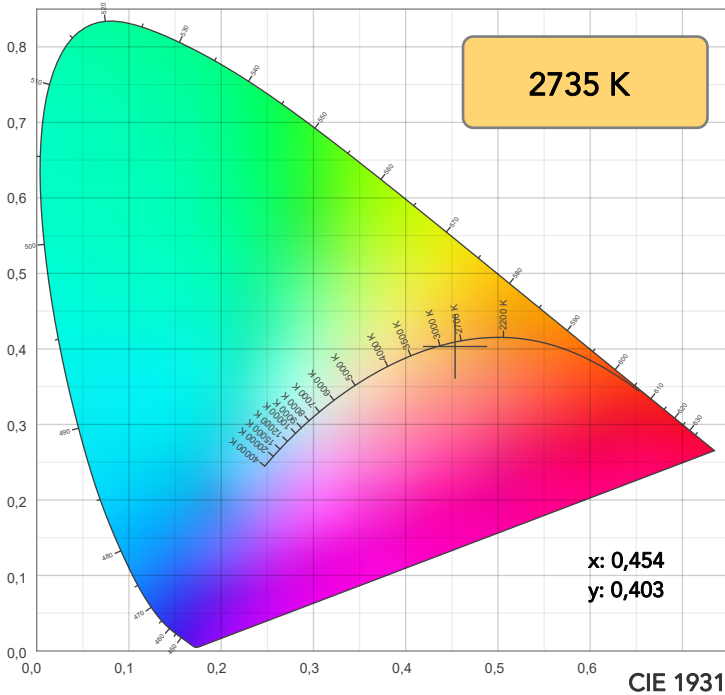

TM30: 93,4

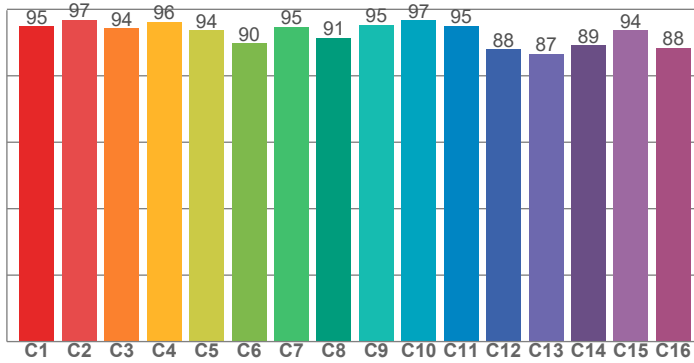

CRI: 95,7 (R1-R8)

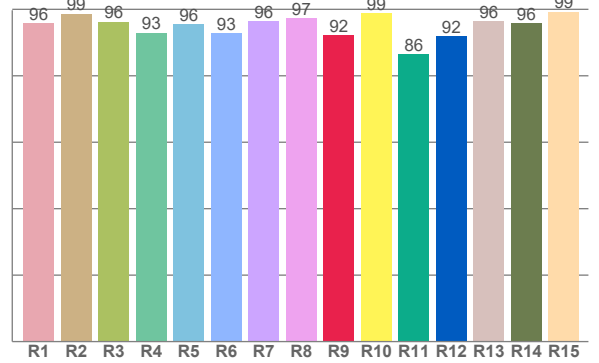

CQS: 93,6

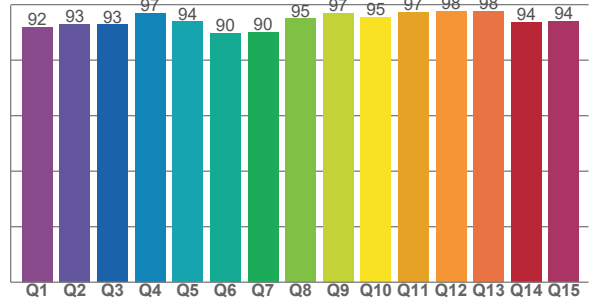

CRI R values, only R1-R8 are used to calculate final CRI value

R1	R2	R3	R4	R5	R6	R7	R8	R9	R10	R11	R12	R13	R14	R15
95,8	98,6	96,3	92,9	95,6	92,8	96,3	97,3	92,1	98,9	86,5	92,0	96,4	95,9	99,3

TM30 C values, 16 binned values out of total of 99 C values

C1	C2	C3	C4	C5	C6	C7	C8	C9	C10	C11	C12	C13	C14	C15	C16
94,8	96,8	94,2	96,1	93,6	89,7	94,6	91,4	95,4	96,7	95,0	88,0	86,6	89,1	93,7	88,4

CQS Q values

Q1	Q2	Q3	Q4	Q5	Q6	Q7	Q8	Q9	Q10	Q11	Q12	Q13	Q14	Q15
92,0	92,9	92,8	96,9	93,9	89,7	90,2	95,0	97,0	95,4	97,4	97,6	97,6	93,8	94,0

COLOR PARAMETERS

Color temperature	Color rendering index	Red component	Color fidelity	Color gamut	Color quality scale	Television lighting index	Color coordinate cie 1931	Color coordinate cie 1931	Color deviation from black body
CCT	CRI	CRI R9	TM30 Rf	TM30 Rg	CQS	TLCI	x	y	Δuv
2735 K	95,7	92,1	93,4	103,8	93,6	84	0,454	0,403	-0,0022

# TM30 DETAILS

**Rf 93,4**  
Fidelity index Rf

**Rg 103,8**  
Gammut index

Hue Bin	R <sub>f</sub>	Graphic shifts (%)	
		Chroma	Hue
1	95	-2%	0%
2	97	0%	1%
3	94	1%	2%
4	96	0%	1%
5	94	3%	4%
6	90	6%	3%
7	95	3%	-1%
8	91	5%	-3%
9	95	2%	-1%
10	97	1%	0%
11	95	2%	2%
12	88	5%	-4%
13	87	4%	-10%
14	89	3%	-8%
15	94	0%	-3%
16	88	-1%	-9%

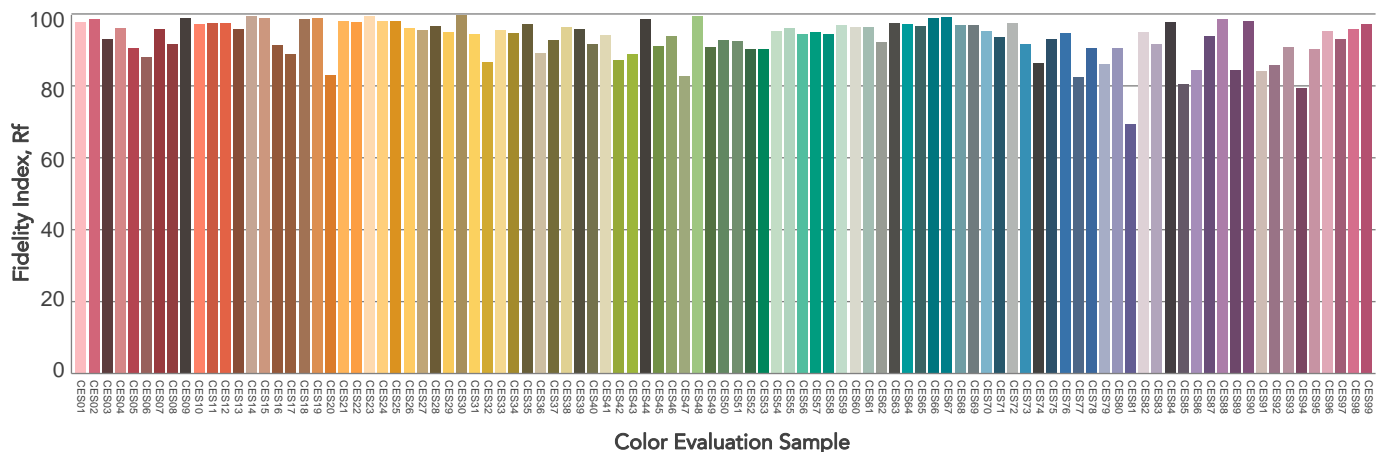
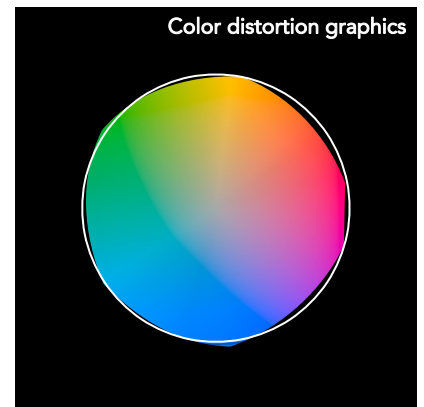
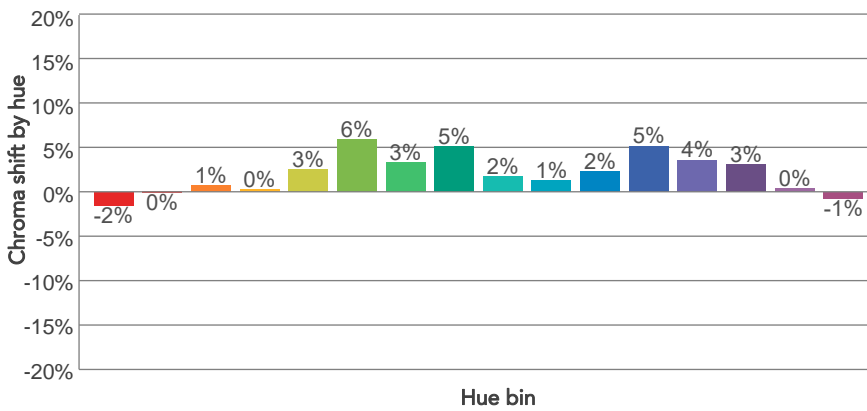
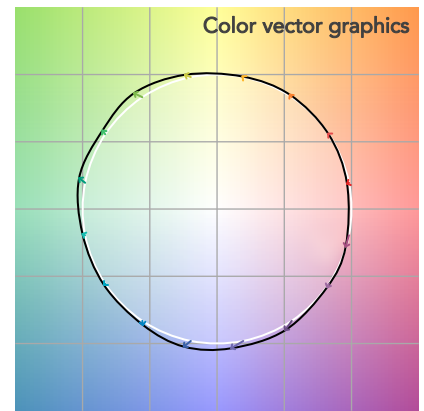
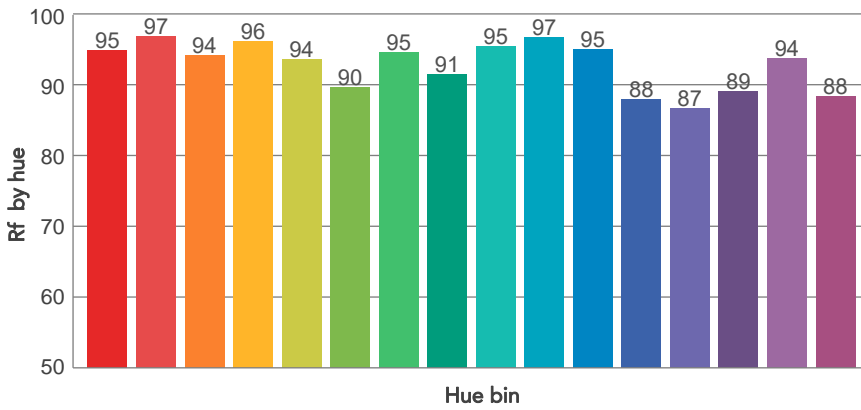
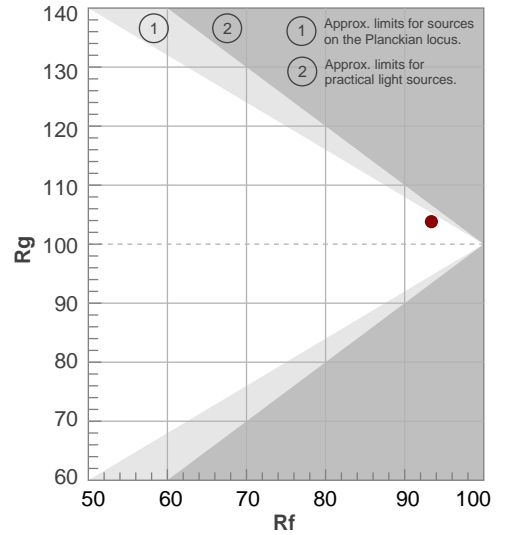

# BEAM DETAILS



Beam angle 50%	Field angle 10%	Cut off angle 2,5%	Intensity ratio in 120° cone	Intensity ratio in 90° cone
52°	73,7°	81,1°	100,0%	99,8%

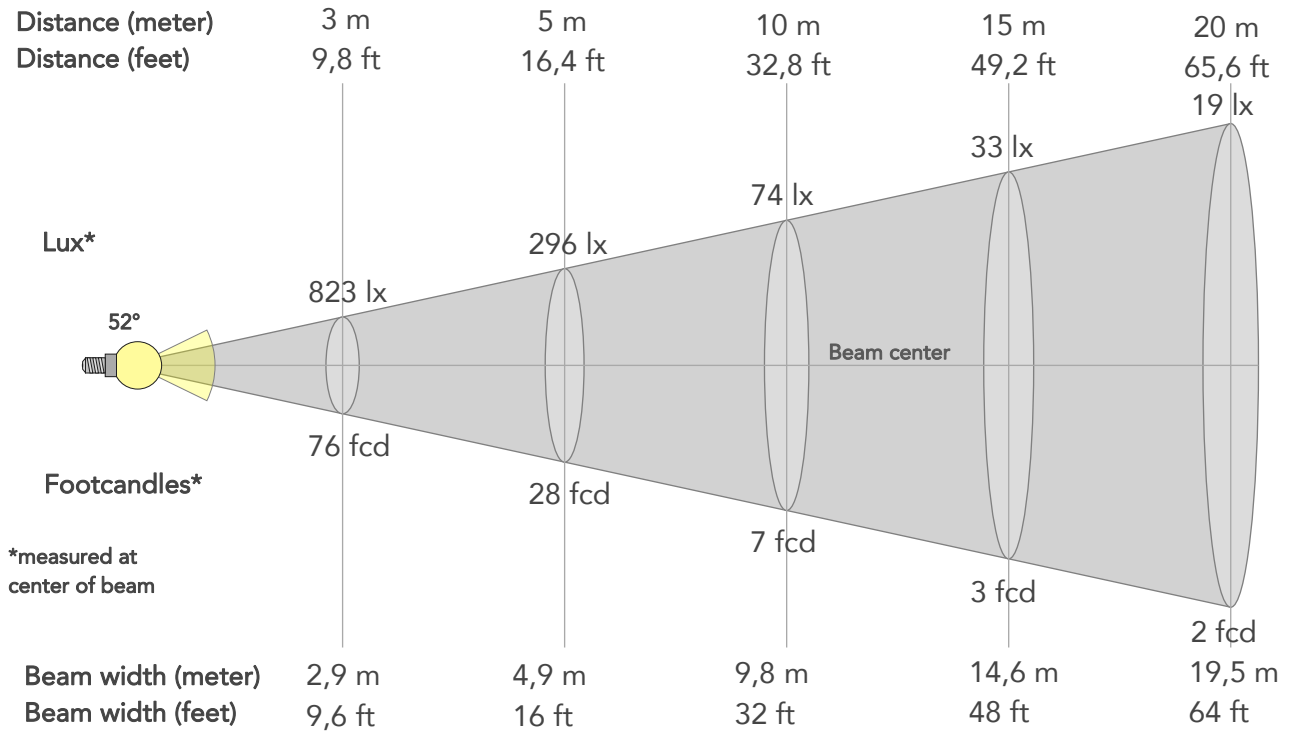

## BEAM INTENSITIES AND WIDTHS

Distance	1m	2m	3m	4m	5m	7,5m	10m	15m	20m	25m	30m	40m	50m
Distance	3,3ft	6,6ft	9,8ft	13,1ft	16,4ft	24,6ft	32,8ft	49,2ft	65,6ft	82ft	98,4ft	131,2ft	164ft
Lux	7406lx	1852lx	823lx	463lx	296lx	132lx	74lx	33lx	19lx	12lx	8lx	5lx	3lx
Footcand.	688fcd	172fcd	76fcd	43fcd	28fcd	12fcd	7fcd	3fcd	2fcd	1fcd	1fcd	0fcd	0fcd
Beam wid.	1m	2m	2,9m	3,9m	4,9m	7,3m	9,8m	14,6m	19,5m	24,4m	29,3m	39m	48,8m
Beam wid.	3,2ft	6,4ft	9,6ft	12,8ft	16ft	24ft	32ft	48ft	64ft	80ft	96ft	127,9ft	159,9ft

## LINEAR DISTRIBUTION DIAGRAM

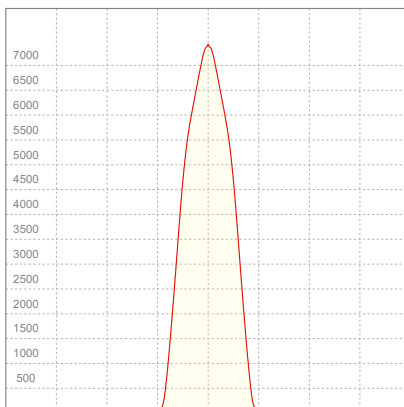

## ELECTRICAL SPECIFICATIONS

Input voltage	Input current	Input power	Effeciency
227V	0,864A	194,8W	25lm/W

## ISO CANDELA DIAGRAM

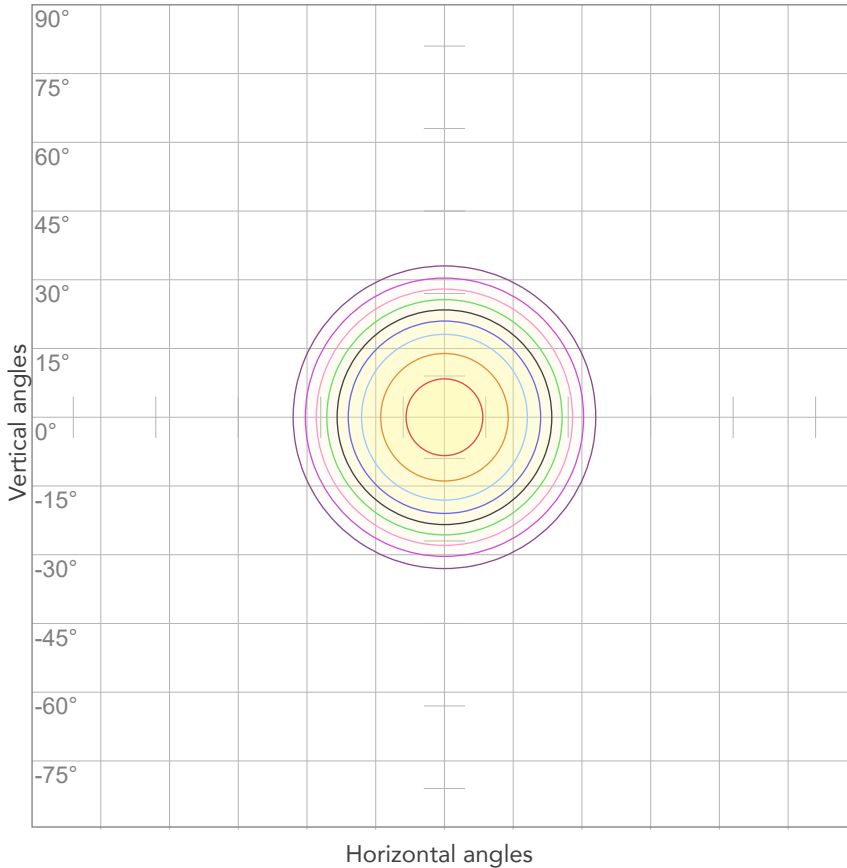

10%	741 cd
20%	1481 cd
30%	2222 cd
40%	2962 cd
50%	3703 cd
60%	4444 cd
70%	5184 cd
80%	5925 cd

Conditions:

Number of c-planes: 2

Candela at center: 7406 cd

## ISO LUX DIAGRAM

MH: 10,0 m

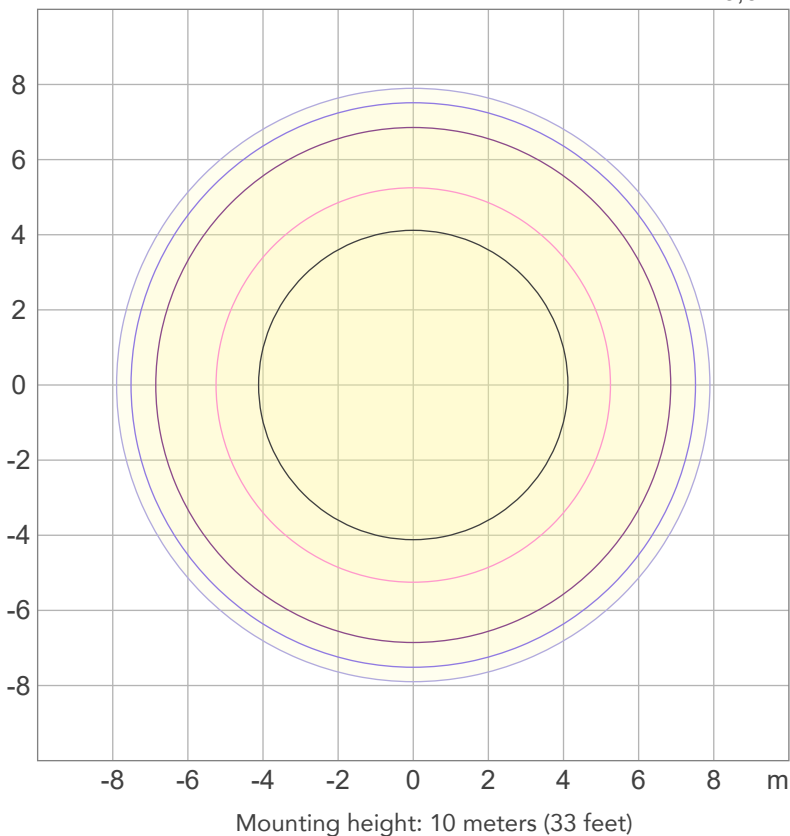

3%	2,22 lx
5%	3,70 lx
10%	7,41 lx
30%	22,2 lx
50%	37,0 lx

Conditions:

Number of c-planes: 2

Lux at center: 74,1 lx

*Lux distribution on a surface when lamp is mounted at 10 meters from the surface.*





Total lumen output:

3572 lm

Peak candela output:

24284 cd

Light quality:

CRI: 95,7

Color temperature:

2767 K

**PRODUCT NAME:**

ECLFRCTPS

**MEASURAMENT CONDITIONS:**

Beam angle:

Med Zoom

Target:

2800K - HB

Operator:

Salvatore Giglio

Date and time:

02/10/2023 17:12:57

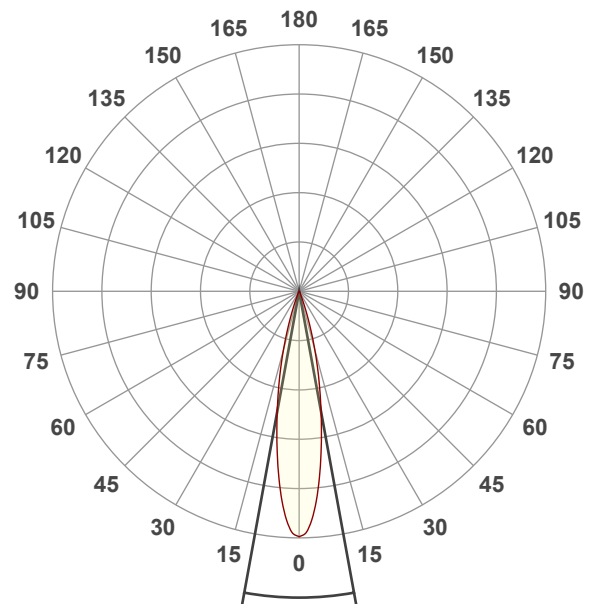

Spectra

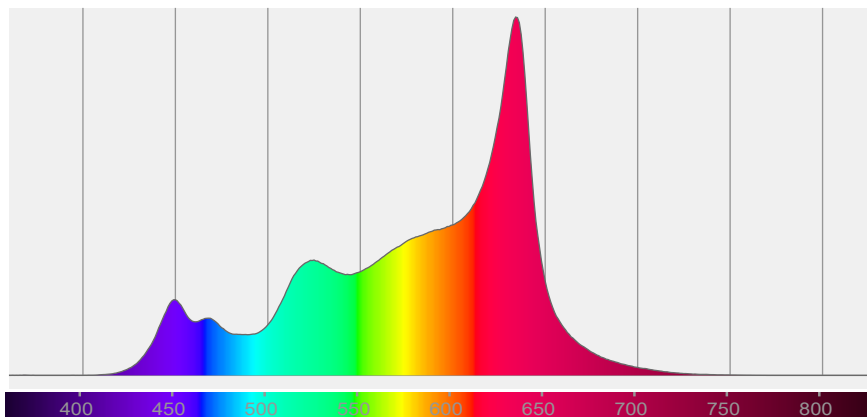

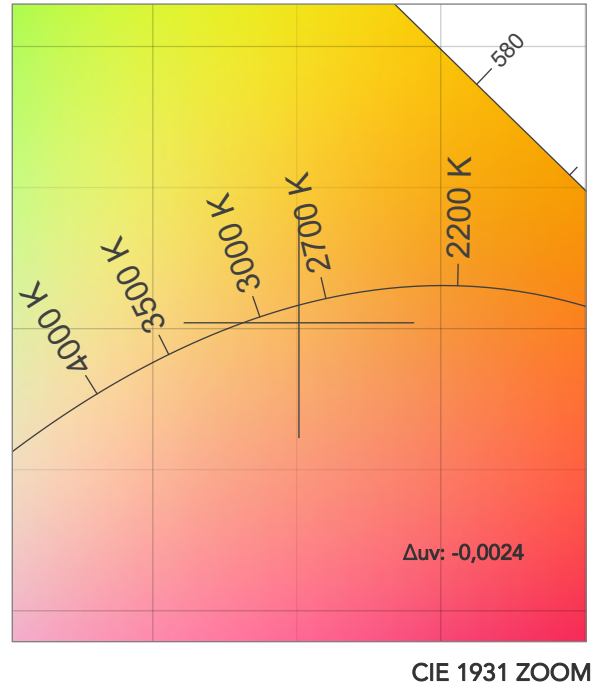
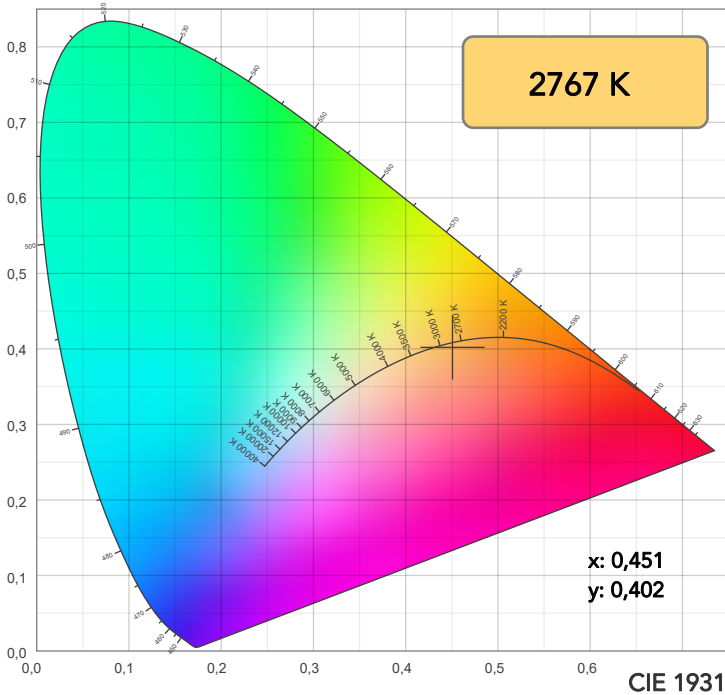

TM30: 93,6

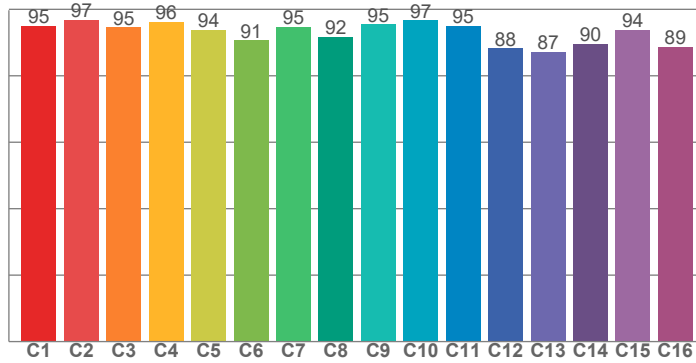

CRI: 95,7 (R1-R8)

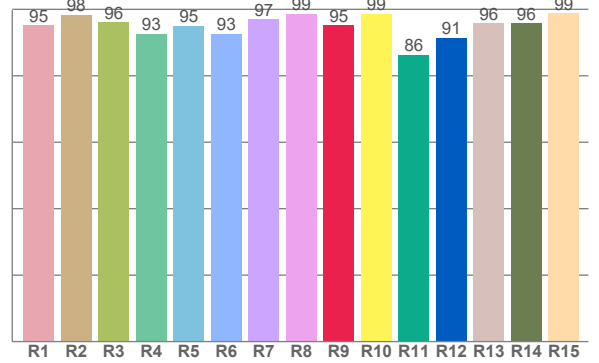

CQS: 94,0

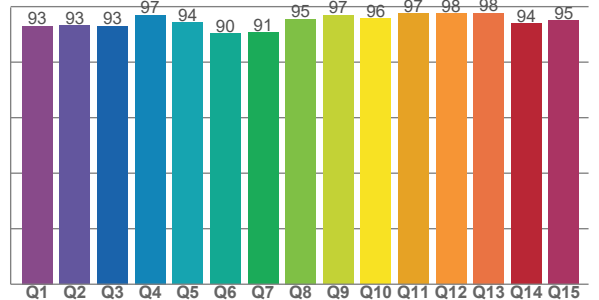

CRI R values, only R1-R8 are used to calculate final CRI value

R1	R2	R3	R4	R5	R6	R7	R8	R9	R10	R11	R12	R13	R14	R15
95,2	98,4	96,0	92,6	95,1	92,6	96,9	98,6	95,2	98,6	86,3	91,5	95,9	95,7	98,7

TM30 C values, 16 binned values out of total of 99 C values

C1	C2	C3	C4	C5	C6	C7	C8	C9	C10	C11	C12	C13	C14	C15	C16
95,1	96,8	94,5	96,3	93,8	90,7	94,8	91,7	95,5	96,7	95,0	88,3	87,1	89,7	93,7	88,8

CQS Q values

Q1	Q2	Q3	Q4	Q5	Q6	Q7	Q8	Q9	Q10	Q11	Q12	Q13	Q14	Q15
93,0	93,2	92,9	97,0	94,3	90,3	90,7	95,5	96,9	95,7	97,4	97,5	97,7	94,0	94,9

COLOR PARAMETERS

Color temperature	Color rendering index	Red component	Color fidelity	Color gamut	Color quality scale	Television lighting index	Color coordinate cie 1931	Color coordinate cie 1931	Color deviation from black body
CCT	CRI	CRI R9	TM30 Rf	TM30 Rg	CQS	TLCI	x	y	Δuv
2767 K	95,7	95,2	93,6	103,8	94,0	85	0,451	0,402	-0,0024

# TM30 DETAILS

**Rf 93,6**  
Fidelity index Rf

**Rg 103,8**  
Gammut index

Hue Bin	R <sub>f</sub>	Graphic shifts (%)	
		Chroma	Hue
1	95	-1%	0%
2	97	0%	0%
3	95	1%	2%
4	96	0%	0%
5	94	2%	4%
6	91	5%	3%
7	95	3%	0%
8	92	5%	-2%
9	95	2%	-1%
10	97	1%	0%
11	95	3%	2%
12	88	5%	-4%
13	87	3%	-9%
14	90	3%	-7%
15	94	0%	-2%
16	89	0%	-8%

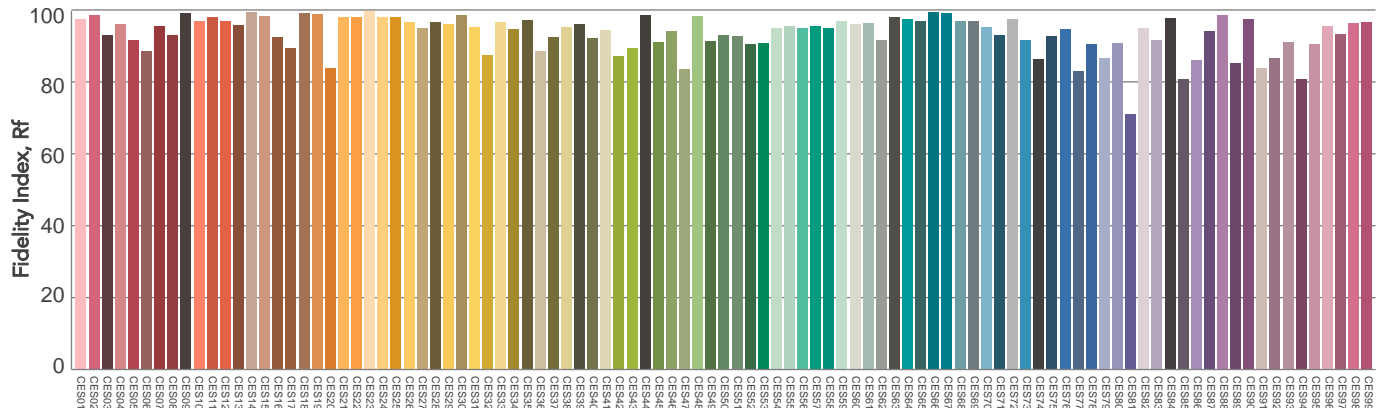
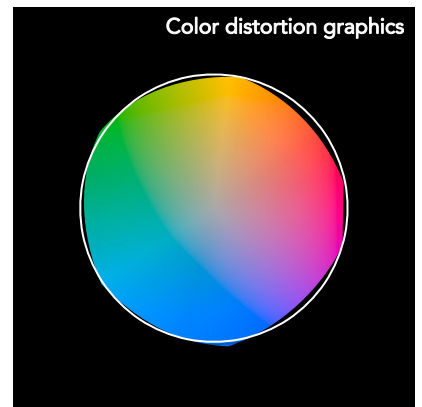
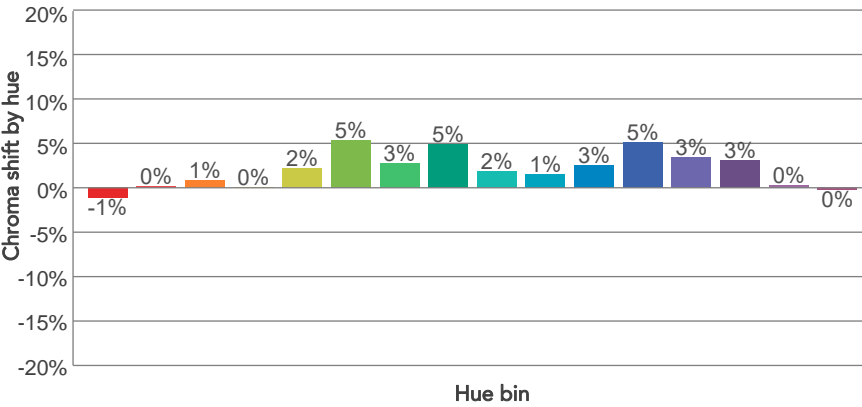
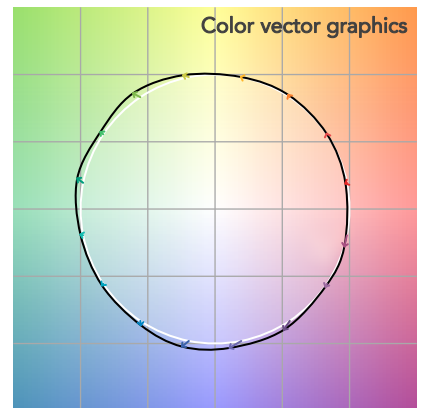
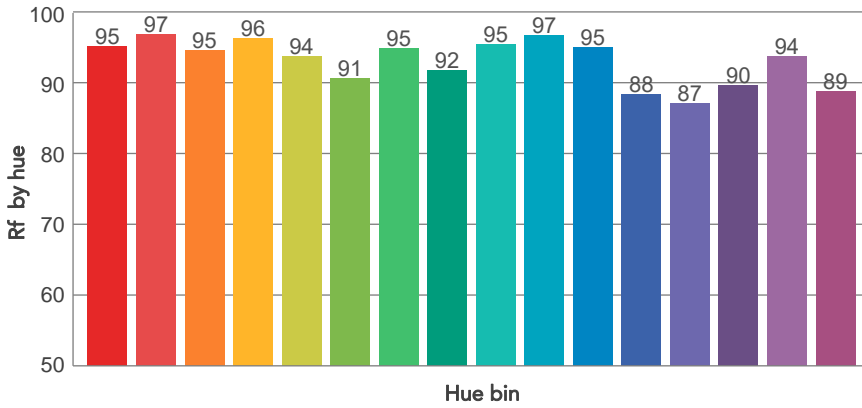
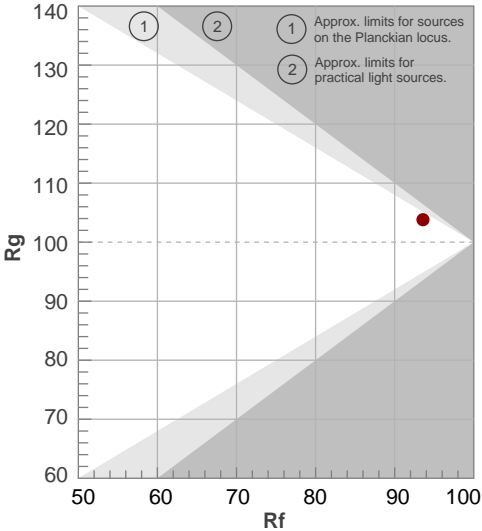

Color Evaluation Sample

# BEAM DETAILS



Beam angle 50%	Field angle 10%	Cut off angle 2,5%	Intensity ratio in 120° cone	Intensity ratio in 90° cone
20,6°	37,4°	45,6°	100,0%	99,9%

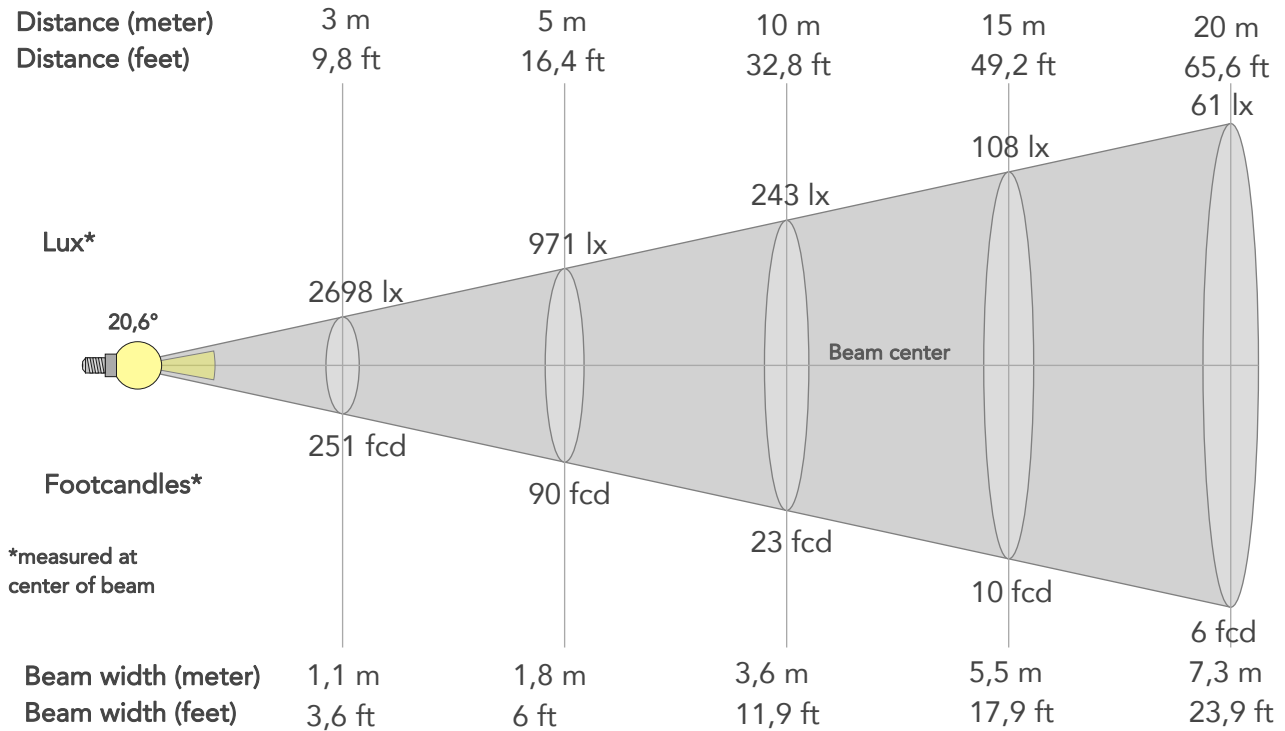

## BEAM INTENSITIES AND WIDTHS

Distance	1m	2m	3m	4m	5m	7,5m	10m	15m	20m	25m	30m	40m	50m
Distance	3,3ft	6,6ft	9,8ft	13,1ft	16,4ft	24,6ft	32,8ft	49,2ft	65,6ft	82ft	98,4ft	131,2ft	164ft
Lux	24284lx	6071lx	2698lx	1518lx	971lx	432lx	243lx	108lx	61lx	39lx	27lx	15lx	10lx
Footcand.	2256fcd	564fcd	251fcd	141fcd	90fcd	40fcd	23fcd	10fcd	6fcd	4fcd	3fcd	1fcd	1fcd
Beam wid.	0,4m	0,7m	1,1m	1,5m	1,8m	2,7m	3,6m	5,5m	7,3m	9,1m	10,9m	14,6m	18,2m
Beam wid.	1,2ft	2,4ft	3,6ft	4,8ft	6ft	9ft	11,9ft	17,9ft	23,9ft	29,9ft	35,8ft	47,8ft	59,7ft

## LINEAR DISTRIBUTION DIAGRAM

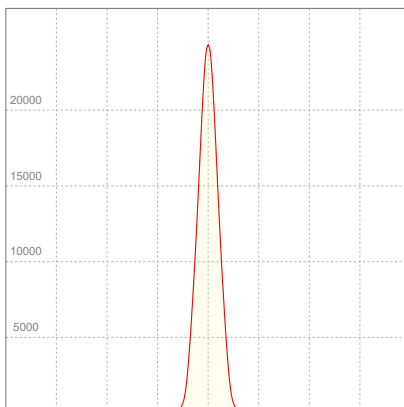

## ELECTRICAL SPECIFICATIONS

Input voltage	Input current	Input power	Effeciency
226V	0,860A	193,5W	18lm/W

## ISO CANDELA DIAGRAM

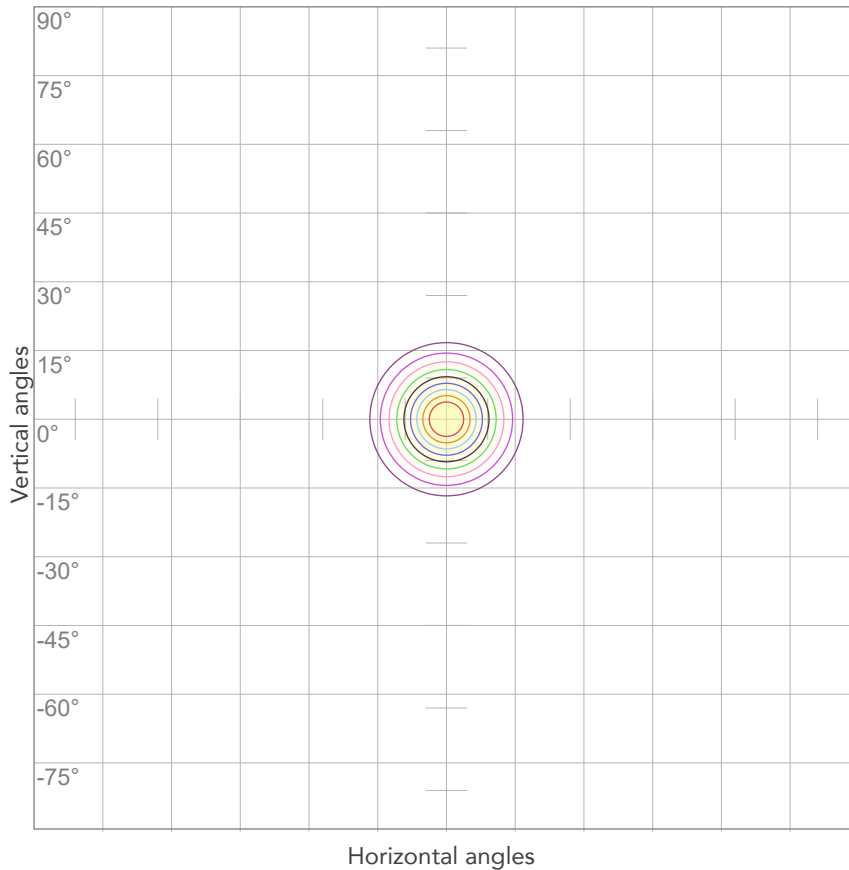

10%	2428 cd
20%	4857 cd
30%	7285 cd
40%	9714 cd
50%	12142 cd
60%	14570 cd
70%	16999 cd
80%	19427 cd

Conditions:

Number of c-planes: 2

Candela at center: 24284 cd

## ISO LUX DIAGRAM

MH: 10,0 m

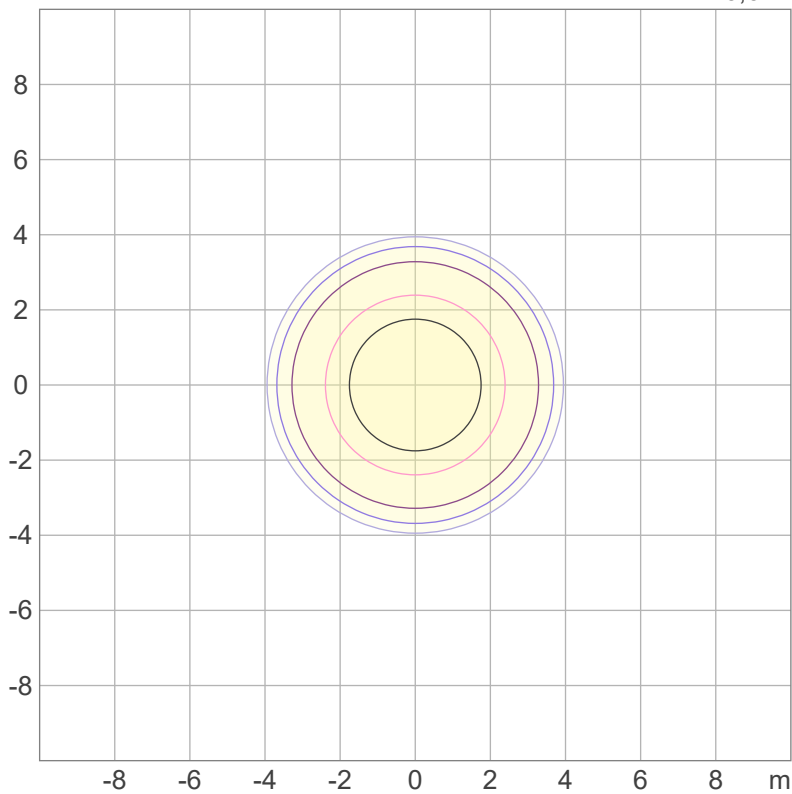

Mounting height: 10 meters (33 feet)

3%	7,29 lx
5%	12,1 lx
10%	24,3 lx
30%	72,9 lx
50%	121 lx

Conditions:

Number of c-planes: 2

Lux at center: 243 lx

*Lux distribution on a surface when lamp is mounted at 10 meters from the surface.*



Total lumen output:

2005 lm

Peak candela output:

58415 cd

Light quality:

CRI: 95,9

Color temperature:

2764 K

**PRODUCT NAME:**

ECLFRCTPS

**MEASURAMENT CONDITIONS:**

Beam angle:

Min Zoom

Target:

2800K - HB

Operator:

Salvatore Giglio

Date and time:

02/10/2023 16:20:06

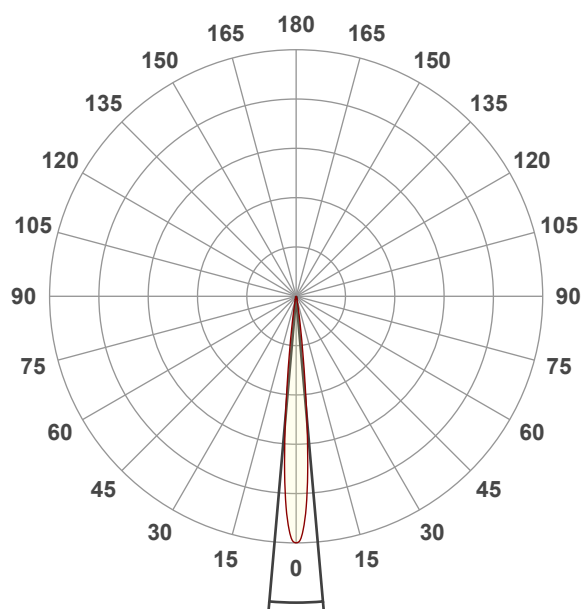

Beam angle 50%: 10°

Field angle 10%: 17°

Cut off angle 2.5%: 23,1°

Spectra

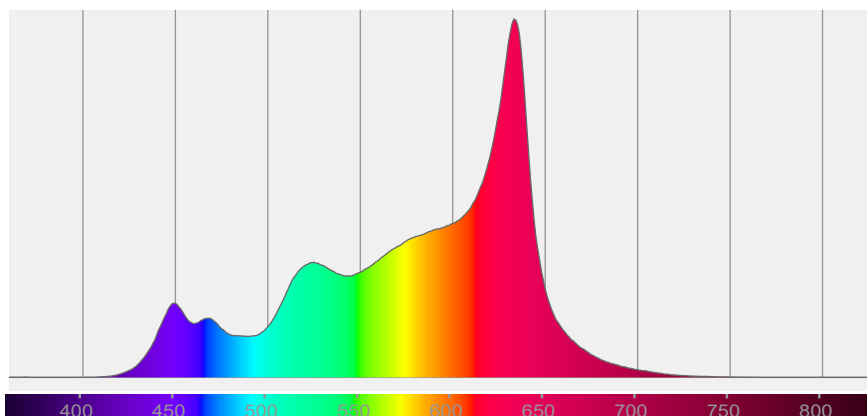

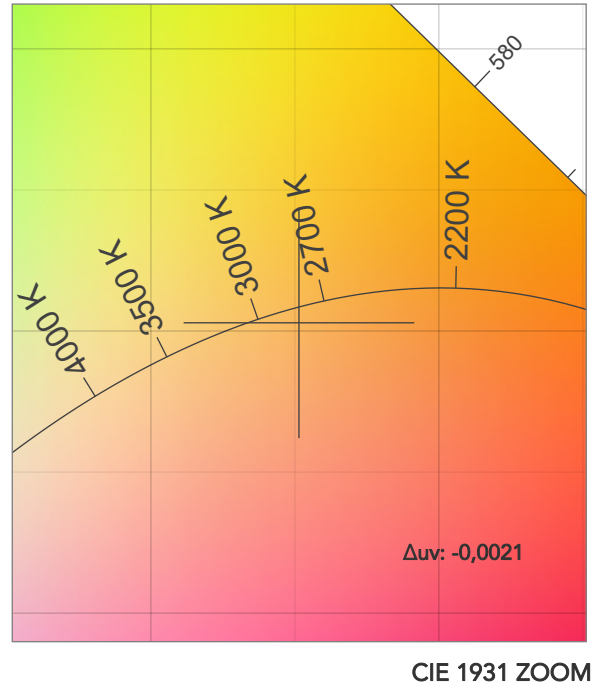
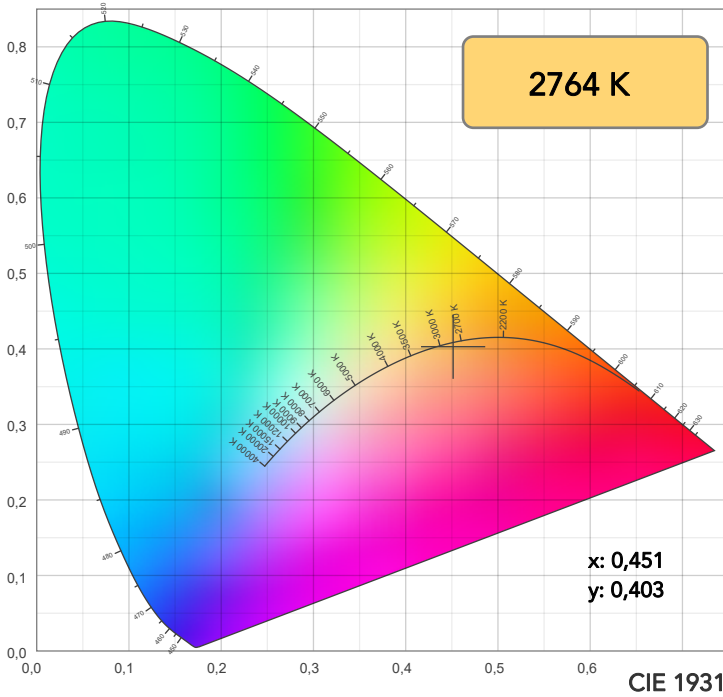

TM30: 93,5

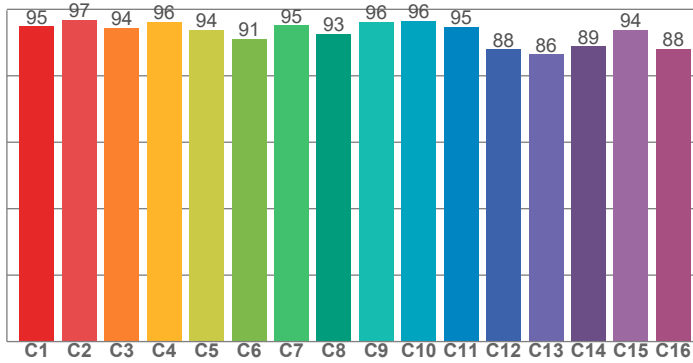

CRI: 95,9 (R1-R8)

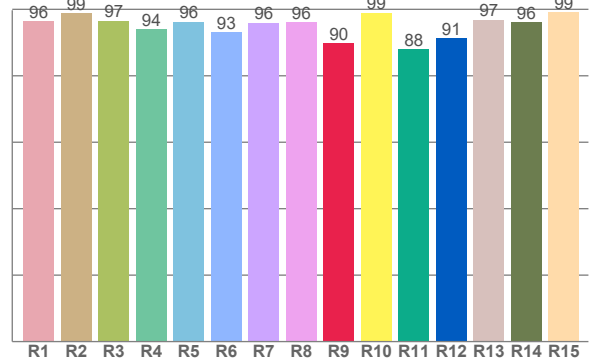

CQS: 93,8

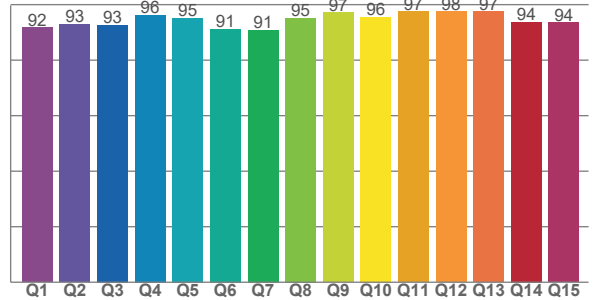

CRI R values, only R1-R8 are used to calculate final CRI value

R1	R2	R3	R4	R5	R6	R7	R8	R9	R10	R11	R12	R13	R14	R15
96,3	98,7	96,6	94,0	96,3	93,0	96,0	96,2	89,8	98,9	88,0	91,3	96,9	96,1	99,1

TM30 C values, 16 binned values out of total of 99 C values

C1	C2	C3	C4	C5	C6	C7	C8	C9	C10	C11	C12	C13	C14	C15	C16
94,9	96,8	94,5	96,3	93,9	91,2	95,2	92,5	96,2	96,4	94,8	88,0	86,4	88,8	93,9	88,1

CQS Q values

Q1	Q2	Q3	Q4	Q5	Q6	Q7	Q8	Q9	Q10	Q11	Q12	Q13	Q14	Q15
91,7	92,9	92,7	96,3	95,2	91,2	90,8	95,1	97,2	95,5	97,5	97,6	97,5	93,8	93,5

COLOR PARAMETERS

Color temperature	Color rendering index	Red component	Color fidelity	Color gamut	Color quality scale	Television lighting index	Color coordinate cie 1931	Color coordinate cie 1931	Color deviation from black body
CCT	CRI	CRI R9	TM30 Rf	TM30 Rg	CQS	TLCI	x	y	Δuv
2764 K	95,9	89,8	93,5	103,1	93,8	84	0,451	0,403	-0,0021

# TM30 DETAILS

**Rf 93,5**  
Fidelity index Rf

**Rg 103,1**  
Gammut index

Hue Bin	R <sub>f</sub>	Graphic shifts (%)	
		Chroma	Hue
1	95	-2%	0%
2	97	0%	1%
3	94	1%	2%
4	96	0%	0%
5	94	2%	4%
6	91	5%	3%
7	95	2%	0%
8	93	4%	-2%
9	96	2%	0%
10	96	1%	1%
11	95	3%	3%
12	88	5%	-4%
13	86	3%	-10%
14	89	3%	-8%
15	94	0%	-3%
16	88	-1%	-9%

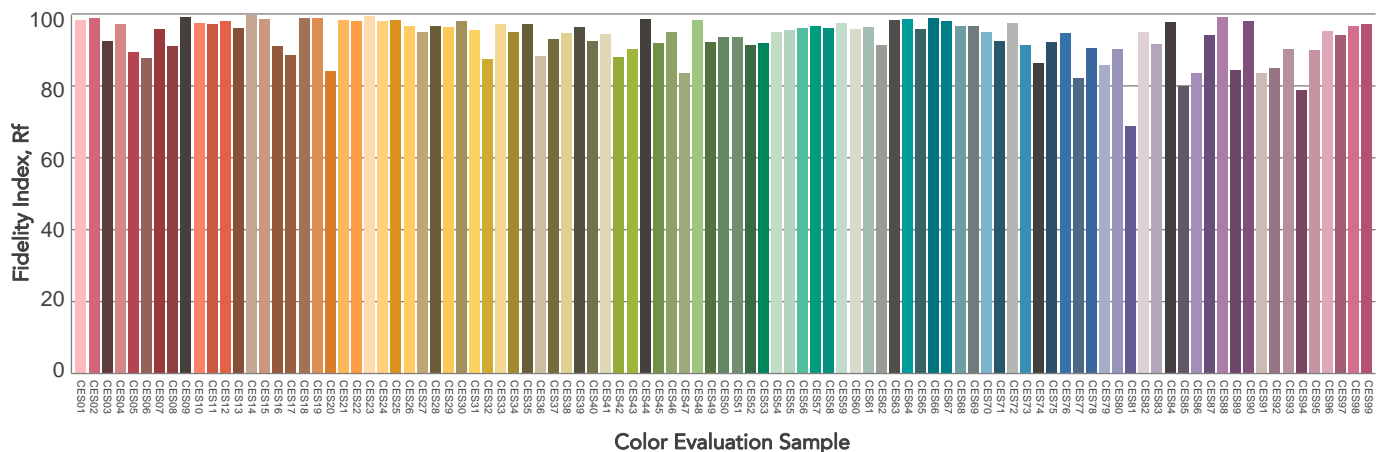
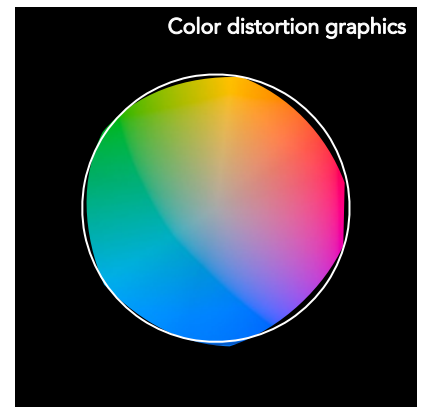
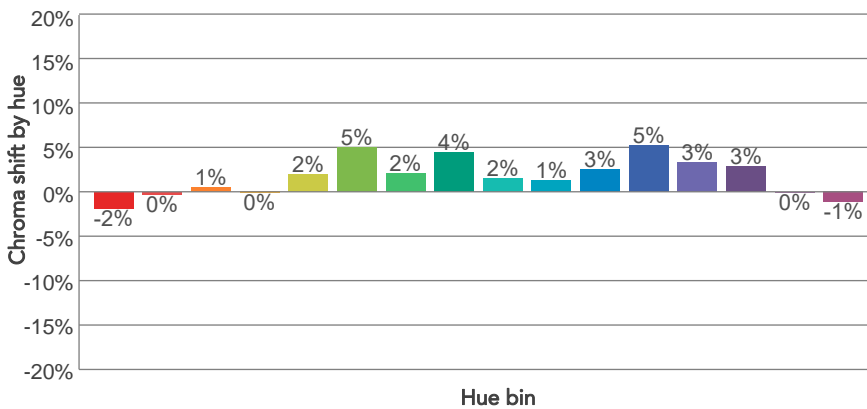
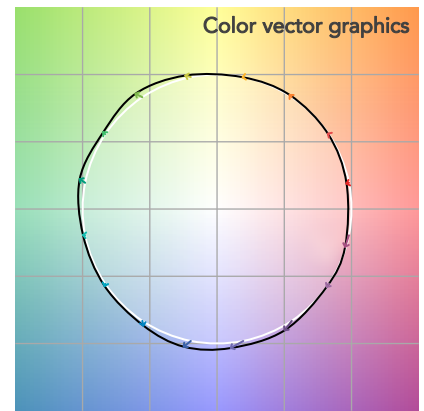
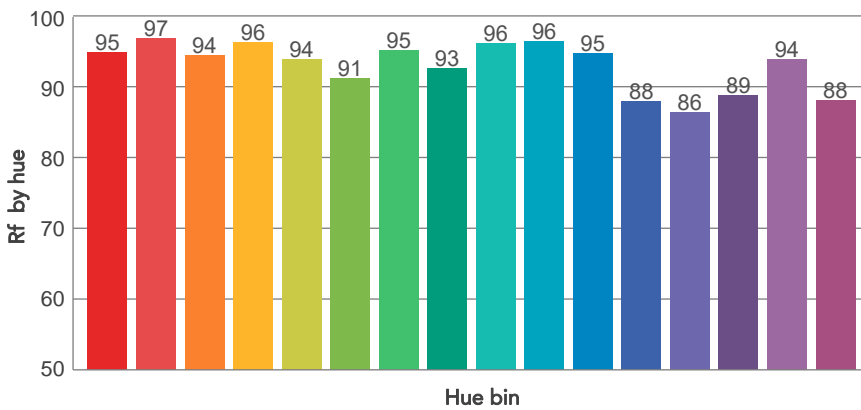
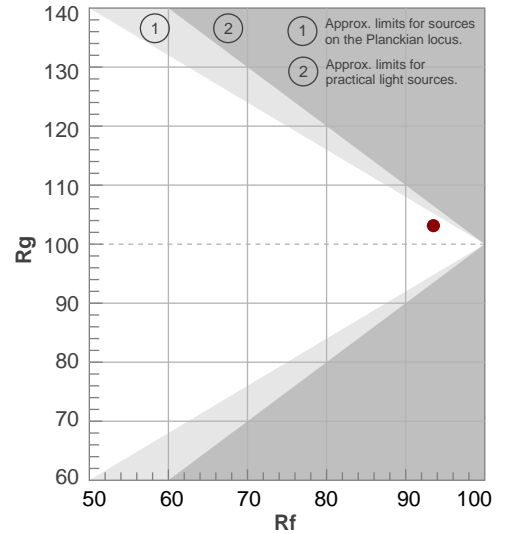



# BEAM DETAILS



Beam angle 50%	Field angle 10%	Cut off angle 2,5%	Intensity ratio in 120° cone	Intensity ratio in 90° cone
10°	17°	23,1°	100,0%	100,0%

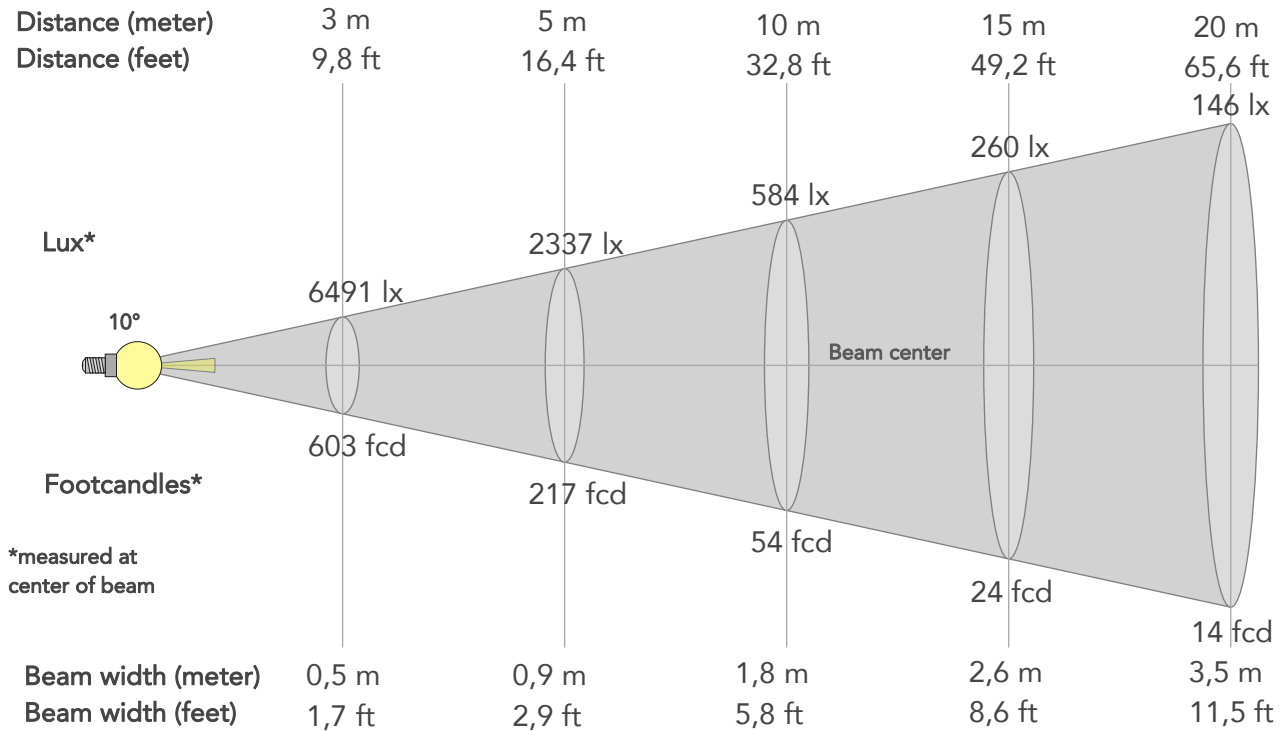

## BEAM INTENSITIES AND WIDTHS

Distance	1m	2m	3m	4m	5m	7,5m	10m	15m	20m	25m	30m	40m	50m
Distance	3,3ft	6,6ft	9,8ft	13,1ft	16,4ft	24,6ft	32,8ft	49,2ft	65,6ft	82ft	98,4ft	131,2ft	164ft
Lux	58415lx	14604lx	6491lx	3651lx	2337lx	1038lx	584lx	260lx	146lx	93lx	65lx	37lx	23lx
Footcand.	5427fcd	1357fcd	603fcd	339fcd	217fcd	96fcd	54fcd	24fcd	14fcd	9fcd	6fcd	3fcd	2fcd
Beam wid.	0,2m	0,4m	0,5m	0,7m	0,9m	1,3m	1,8m	2,6m	3,5m	4,4m	5,3m	7m	8,8m
Beam wid.	0,6ft	1,2ft	1,7ft	2,3ft	2,9ft	4,3ft	5,8ft	8,6ft	11,5ft	14,4ft	17,3ft	23ft	28,8ft

## LINEAR DISTRIBUTION DIAGRAM

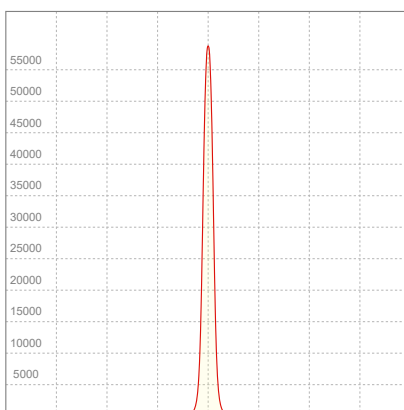

## ELECTRICAL SPECIFICATIONS

Input voltage	Input current	Input power	Effeciency
226V	0,868A	195,4W	10lm/W

## ISO CANDELA DIAGRAM

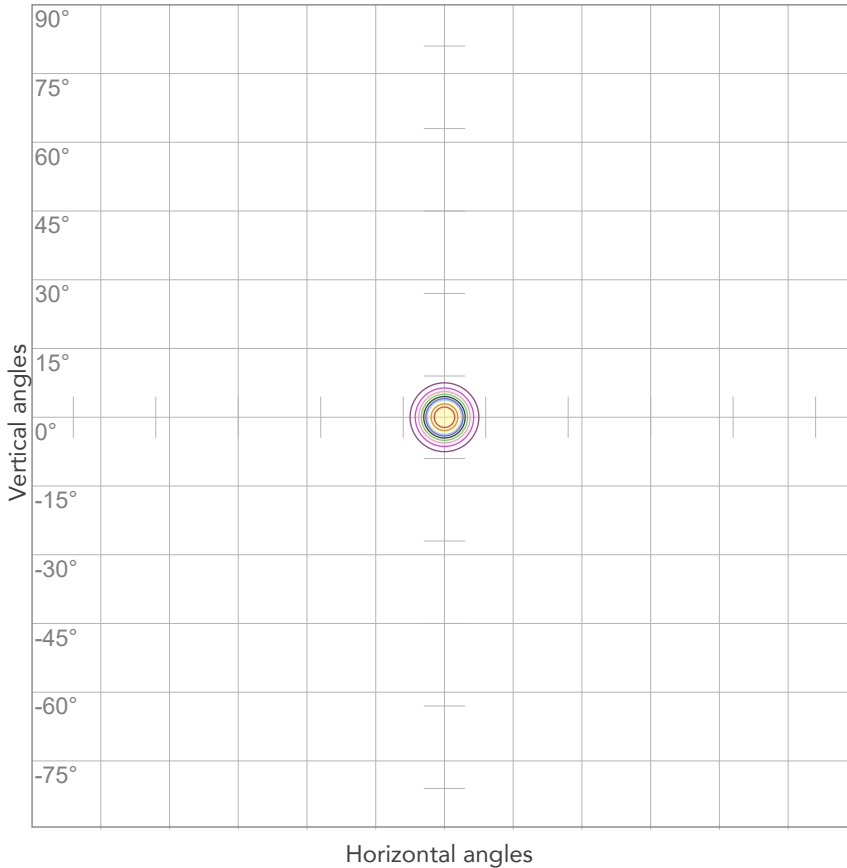

10%	5841 cd
20%	11683 cd
30%	17524 cd
40%	23366 cd
50%	29207 cd
60%	35049 cd
70%	40890 cd
80%	46732 cd

Conditions:

Number of c-planes: 2

Candela at center: 58415 cd

## ISO LUX DIAGRAM

MH: 10,0 m

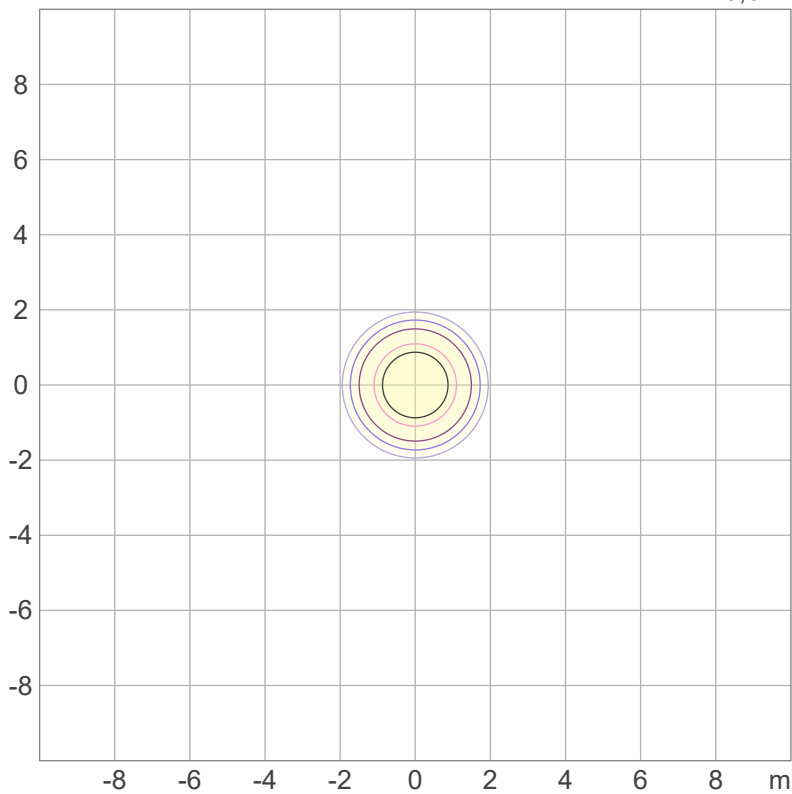

Mounting height: 10 meters (33 feet)

3%	17,5 lx
5%	29,2 lx
10%	58,4 lx
30%	175 lx
50%	292 lx

Conditions:

Number of c-planes: 2

Lux at center: 584 lx

*Lux distribution on a surface when lamp is mounted at 10 meters from the surface.*



Total lumen output:

4965 lm

Peak candela output:

7460 cd

Light quality:

CRI: 93,4

Color temperature:

3114 K

PRODUCT NAME:

ECLFRCTPS

MEASURAMENT CONDITIONS:

Beam angle:

Max Zoom

Target:

3200K - HB

Operator:

Salvatore Giglio

Date and time:

02/10/2023 15:35:29

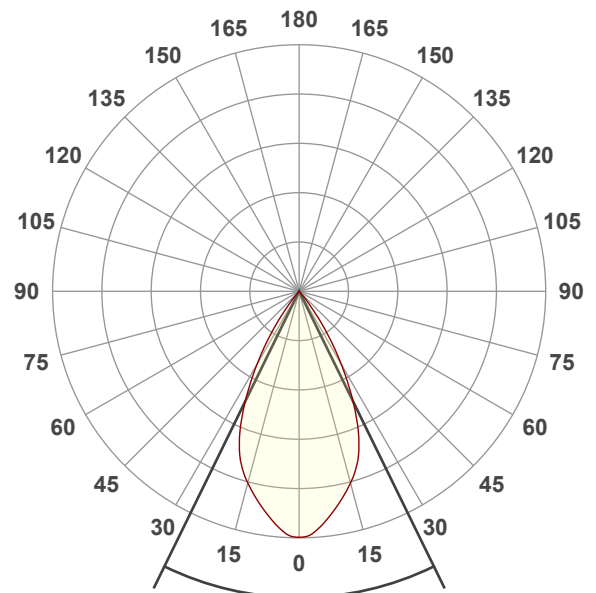

Beam angle 50%: 52,2°

Field angle 10%: 73,8°

Cut off angle 2.5%: 81°

Spectra

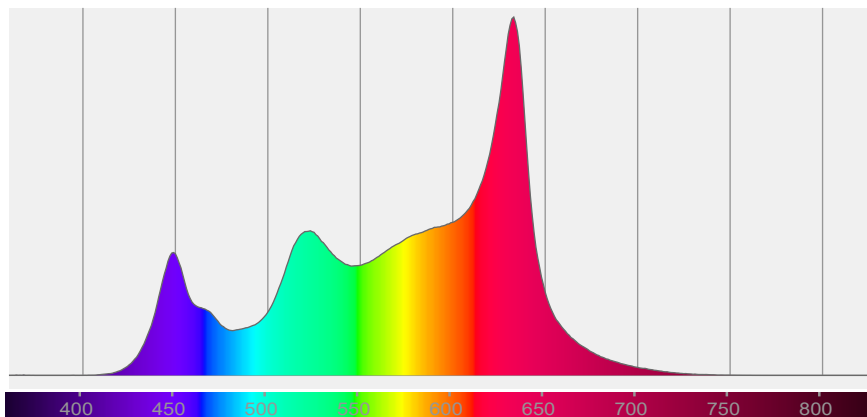

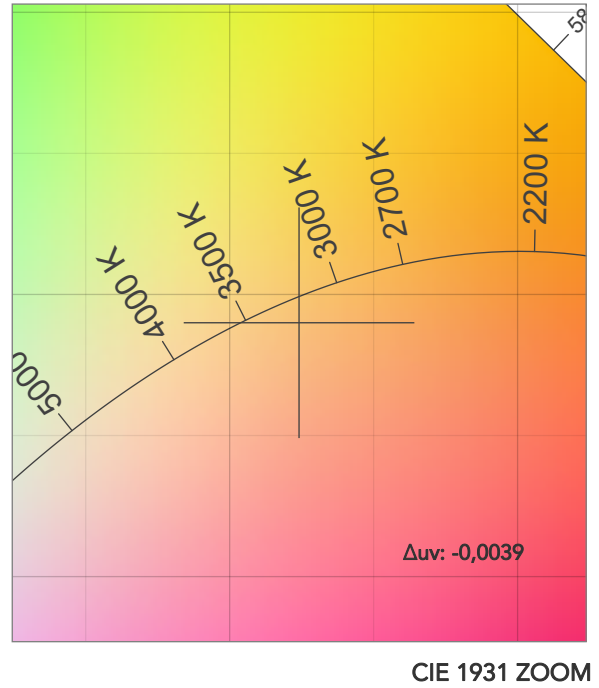
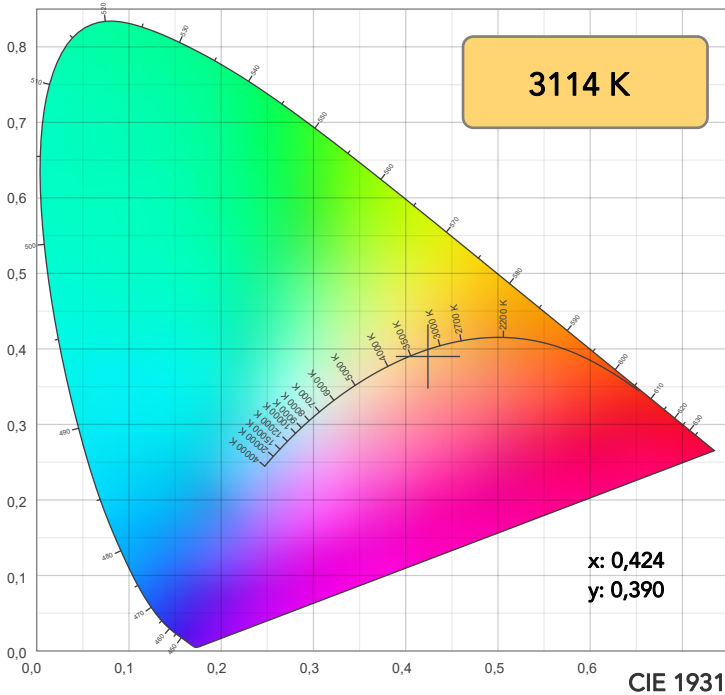

TM30: 92,5

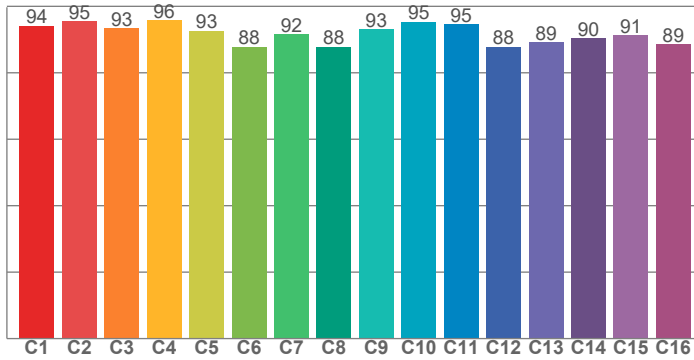

CRI: 93,4 (R1-R8)

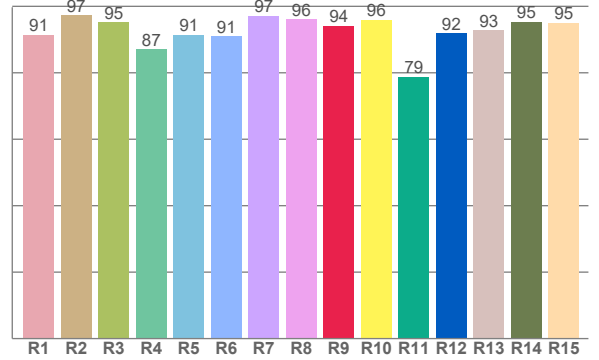

CRI R values, only R1-R8 are used to calculate final CRI value

R1	R2	R3	R4	R5	R6	R7	R8	R9	R10	R11	R12	R13	R14	R15
91,5	97,4	95,2	87,0	91,4	91,1	97,1	96,2	94,2	96,0	78,8	91,8	92,8	95,3	95,1

TM30 C values, 16 binned values out of total of 99 C values

C1	C2	C3	C4	C5	C6	C7	C8	C9	C10	C11	C12	C13	C14	C15	C16
94,2	95,5	93,4	95,8	92,6	87,8	91,6	87,7	93,1	95,3	94,6	87,8	89,1	90,3	91,3	88,6

CQS Q values

Q1	Q2	Q3	Q4	Q5	Q6	Q7	Q8	Q9	Q10	Q11	Q12	Q13	Q14	Q15
94,8	95,5	92,8	96,5	90,6	86,7	91,2	98,1	96,4	96,3	96,3	96,2	96,6	94,3	97,0

CQS: 93,6

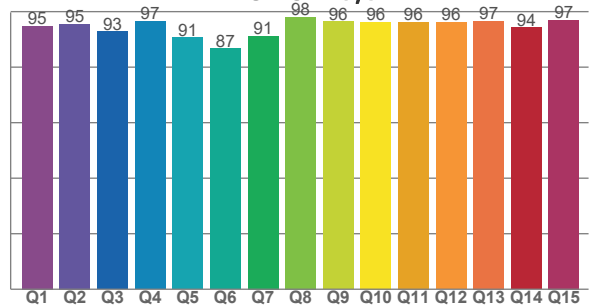

COLOR PARAMETERS

Color temperature	Color rendering index	Red component	Color fidelity	Color gamut	Color quality scale	Television lighting index	Color coordinate cie 1931	Color coordinate cie 1931	Color deviation from black body
CCT	CRI	CRI R9	TM30 Rf	TM30 Rg	CQS	TLCI	x	y	Δuv
3114 K	93,4	94,2	92,5	106,2	93,6	84	0,424	0,390	-0,0039

# TM30 DETAILS



**Rf 92,5**  
Fidelity index Rf

**Rg 106,2**  
Gammut index

Hue Bin	R <sub>f</sub>	Graphic shifts (%)	
		Chroma	Hue
1	94	0%	-1%
2	95	1%	0%
3	93	2%	1%
4	96	2%	1%
5	93	2%	4%
6	88	7%	4%
7	92	5%	-1%
8	88	7%	-3%
9	93	3%	-2%
10	95	1%	-2%
11	95	2%	2%
12	88	6%	-4%
13	89	4%	-7%
14	90	4%	-6%
15	91	2%	-3%
16	89	2%	-8%

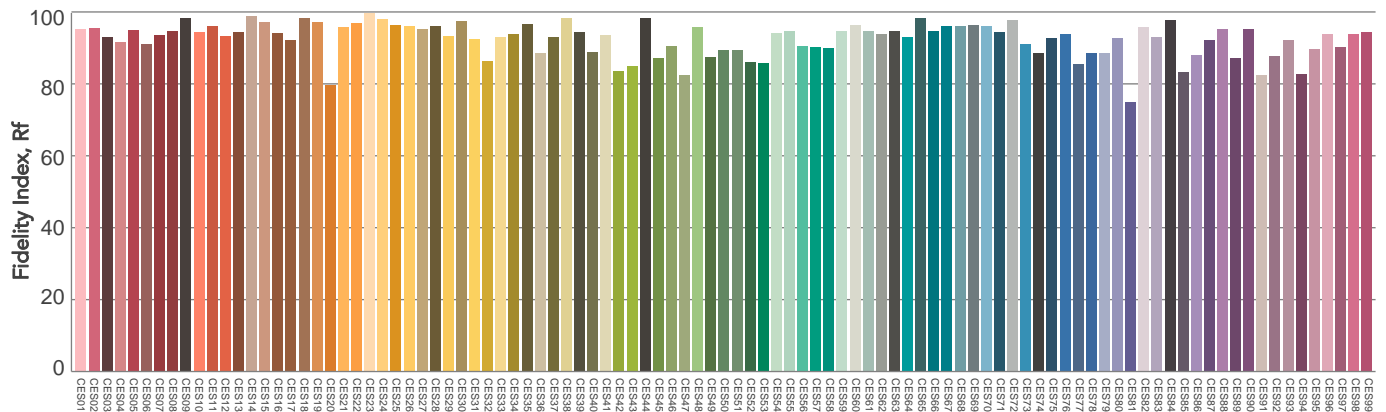
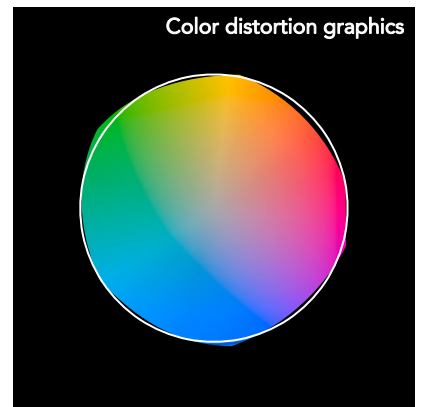
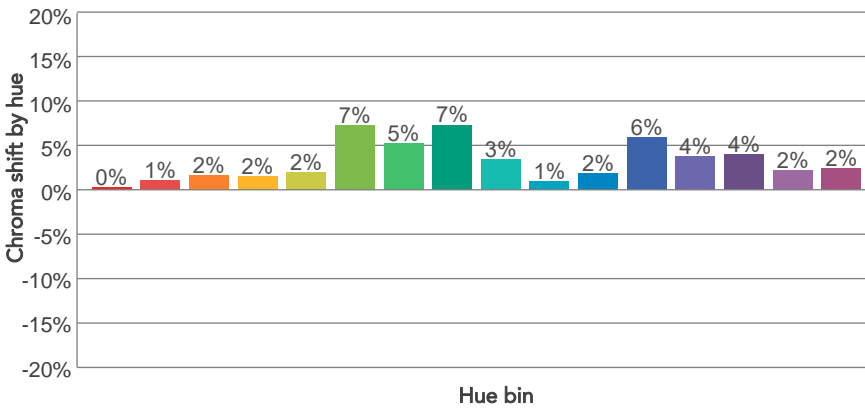
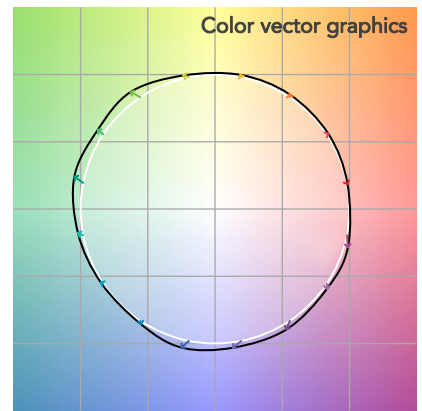
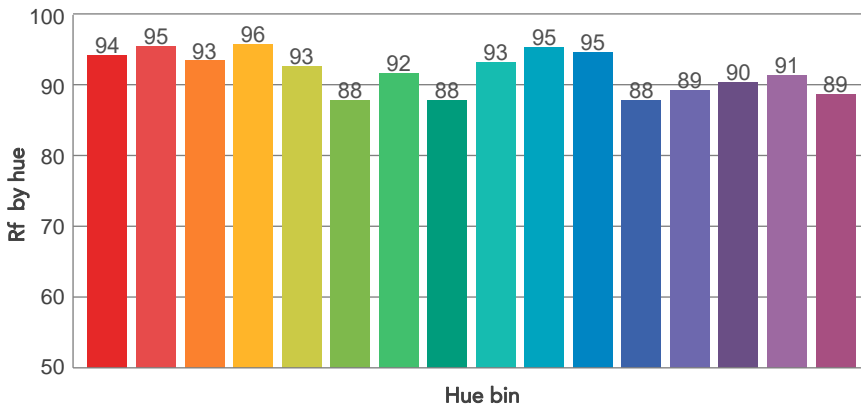
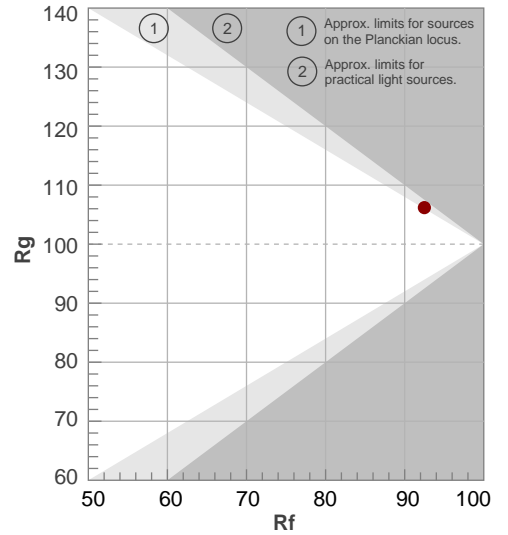

Color Evaluation Sample

# BEAM DETAILS



Beam angle 50%	Field angle 10%	Cut off angle 2,5%	Intensity ratio in 120° cone	Intensity ratio in 90° cone
52,2°	73,8°	81°	100,0%	99,8%

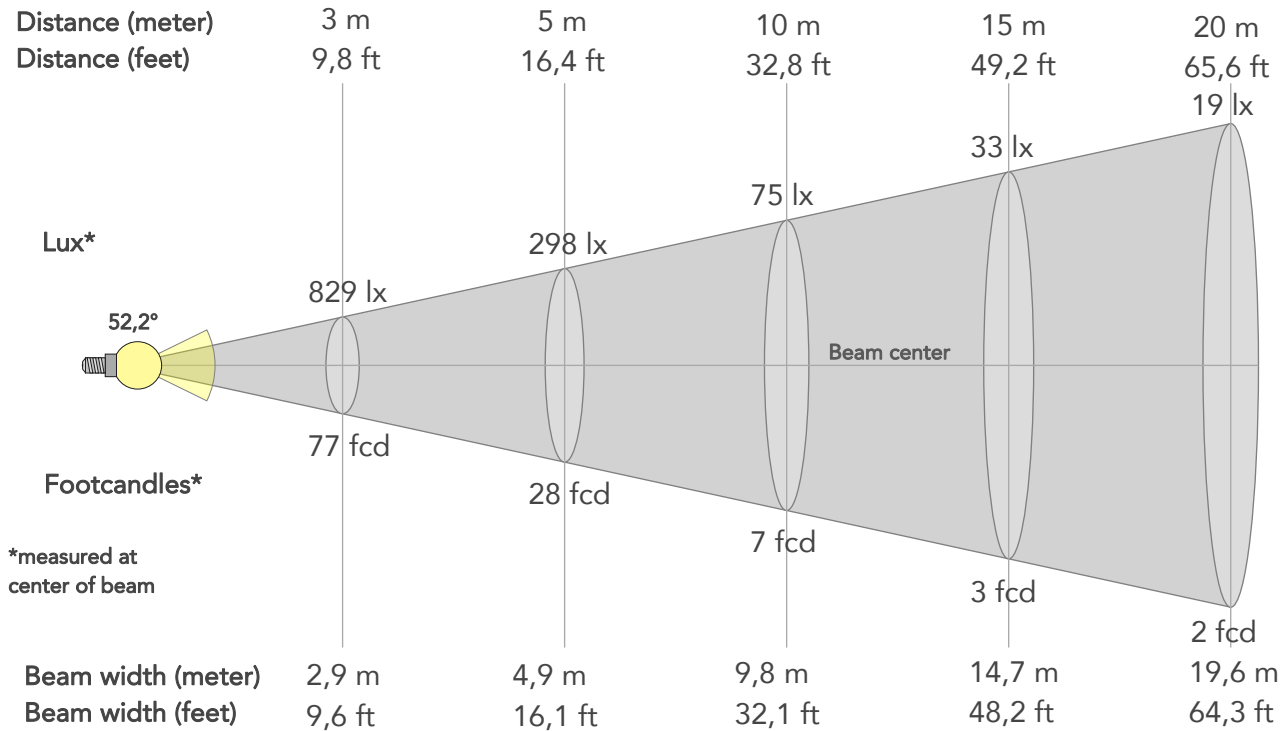

## BEAM INTENSITIES AND WIDTHS

Distance	1m	2m	3m	4m	5m	7,5m	10m	15m	20m	25m	30m	40m	50m
Distance	3,3ft	6,6ft	9,8ft	13,1ft	16,4ft	24,6ft	32,8ft	49,2ft	65,6ft	82ft	98,4ft	131,2ft	164ft
Lux	7460lx	1865lx	829lx	466lx	298lx	133lx	75lx	33lx	19lx	12lx	8lx	5lx	3lx
Footcand.	693fcd	173fcd	77fcd	43fcd	28fcd	12fcd	7fcd	3fcd	2fcd	1fcd	1fcd	0fcd	0fcd
Beam wid.	1m	2m	2,9m	3,9m	4,9m	7,3m	9,8m	14,7m	19,6m	24,5m	29,4m	39,2m	49m
Beam wid.	3,2ft	6,5ft	9,6ft	12,8ft	16,1ft	24,1ft	32,1ft	48,2ft	64,3ft	80,3ft	96,4ft	128,5ft	160,6ft

## LINEAR DISTRIBUTION DIAGRAM

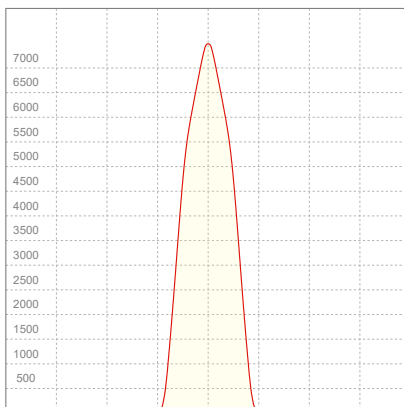

## ELECTRICAL SPECIFICATIONS

Input voltage	Input current	Input power	Effeciency
225V	0,883A	197,5W	25lm/W

## ISO CANDELA DIAGRAM

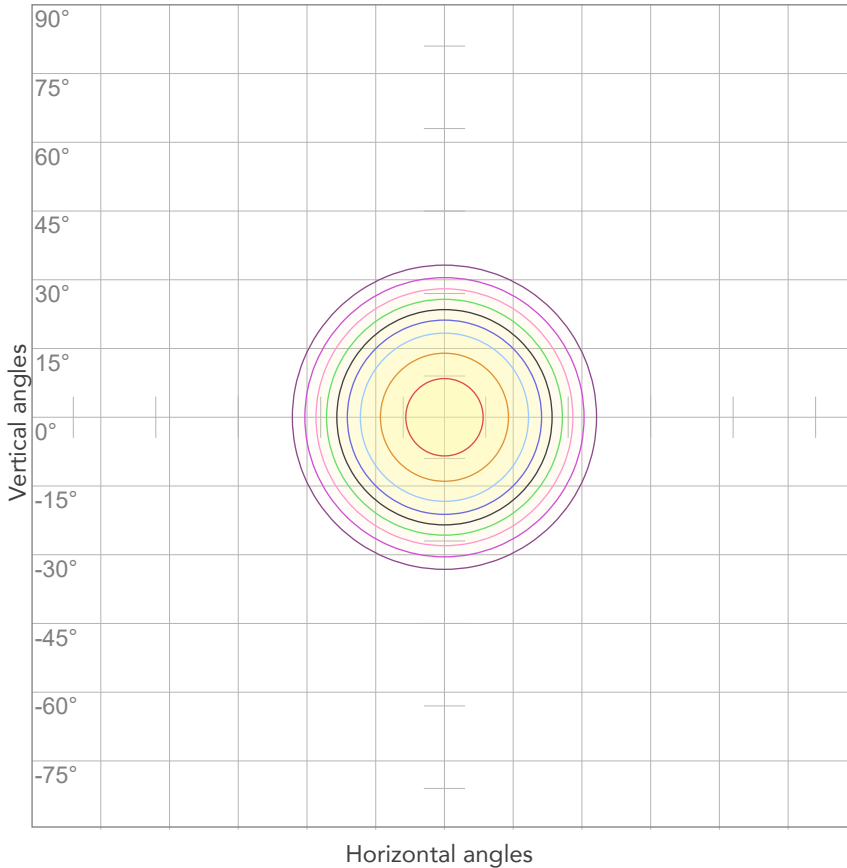

10%	746 cd
20%	1492 cd
30%	2238 cd
40%	2984 cd
50%	3730 cd
60%	4476 cd
70%	5222 cd
80%	5968 cd

Conditions:

Number of c-planes: 2

Candela at center: 7460 cd

## ISO LUX DIAGRAM

MH: 10,0 m

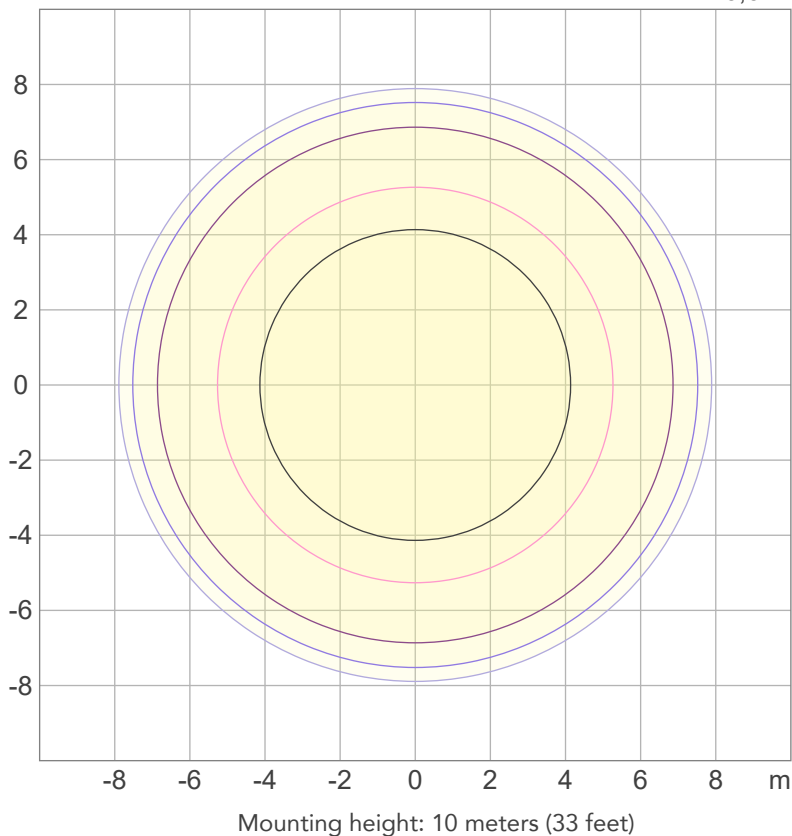

3%	2,24 lx
5%	3,73 lx
10%	7,46 lx
30%	22,4 lx
50%	37,3 lx

Conditions:

Number of c-planes: 2

Lux at center: 74,6 lx

*Lux distribution on a surface when lamp is mounted at 10 meters from the surface.*



Total lumen output:

3503 lm

Peak candela output:

23952 cd

Light quality:

CRI: 92,1

Color temperature:

3149 K

**PRODUCT NAME:**

ECLFRCTPS

**MEASURAMENT CONDITIONS:**

Beam angle:

Med Zoom

Target:

3200K - HB

Operator:

Salvatore Giglio

Date and time:

02/10/2023 17:11:33

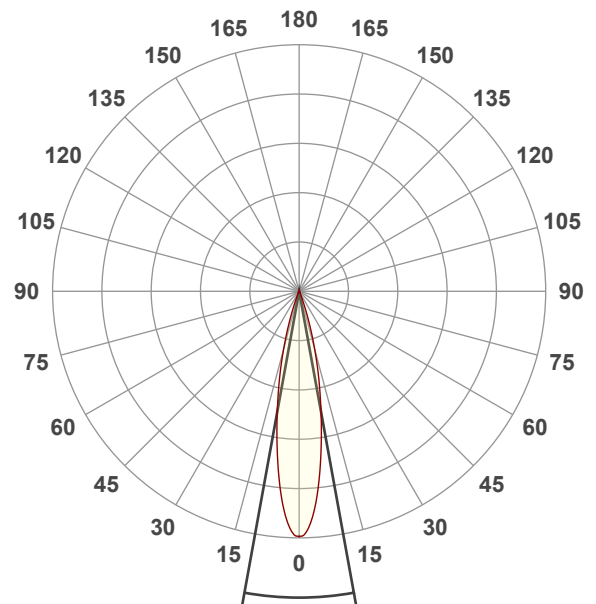

Spectra

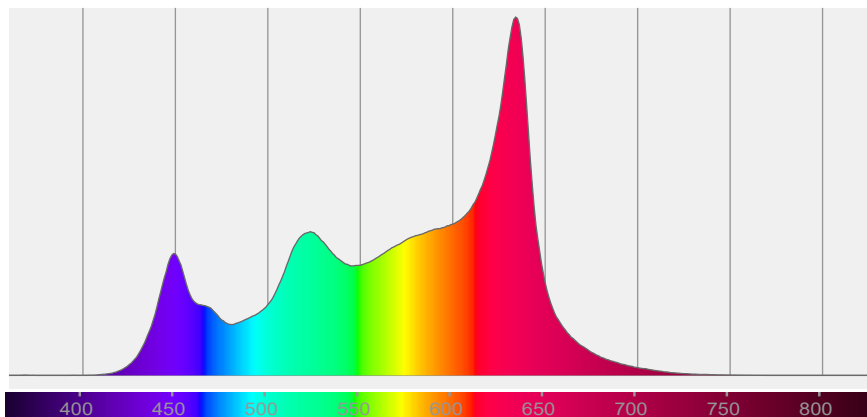



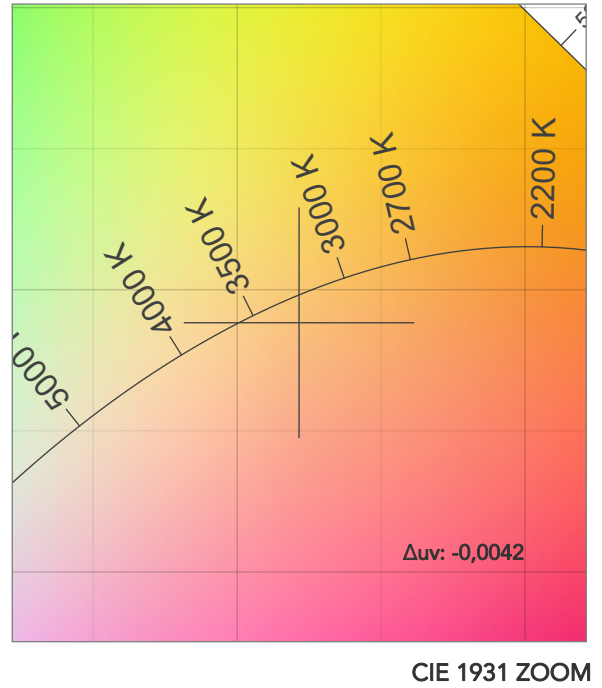
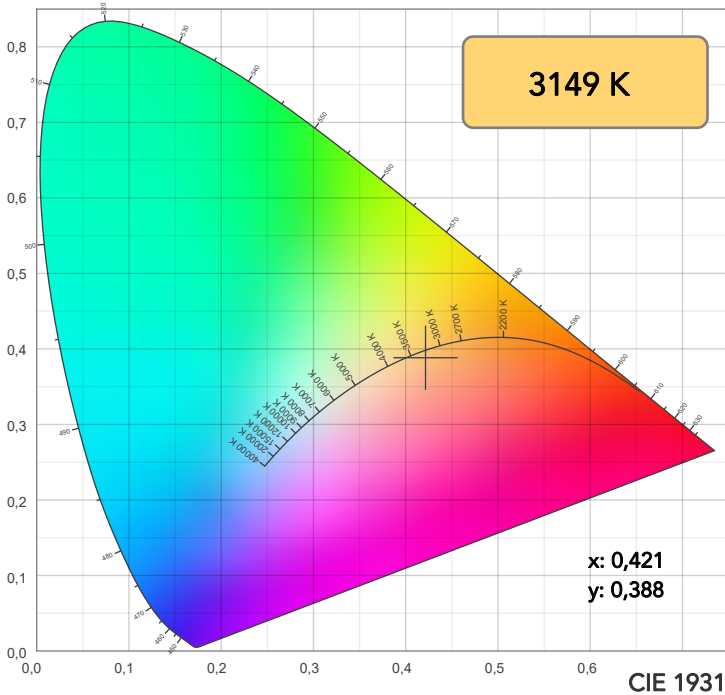

TM30: 92,8

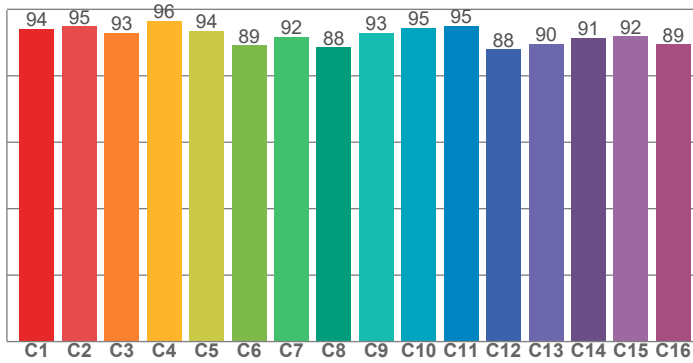

CRI: 92,1 (R1-R8)

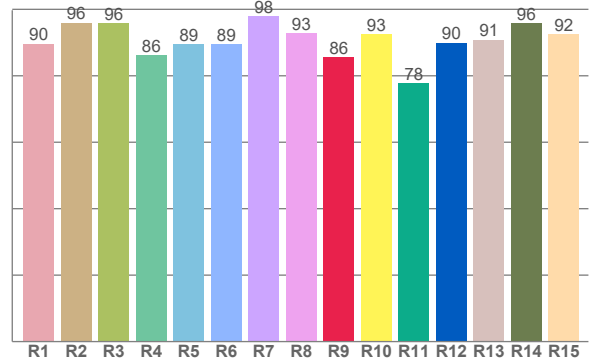

CQS: 94,1

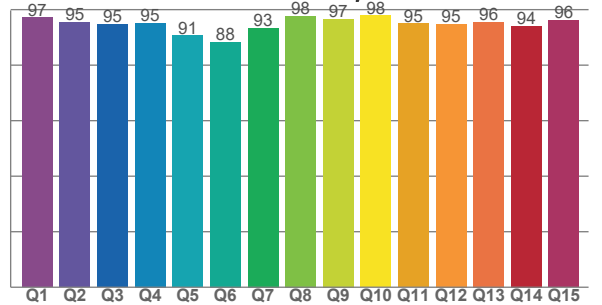

CRI R values, only R1-R8 are used to calculate final CRI value

R1	R2	R3	R4	R5	R6	R7	R8	R9	R10	R11	R12	R13	R14	R15
89,6	96,0	95,8	86,1	89,4	89,4	98,0	92,7	85,5	92,6	77,7	89,9	90,9	95,7	92,4

TM30 C values, 16 binned values out of total of 99 C values

C1	C2	C3	C4	C5	C6	C7	C8	C9	C10	C11	C12	C13	C14	C15	C16
94,1	94,8	92,9	96,5	93,6	89,2	91,8	88,5	92,9	94,5	95,1	88,0	89,6	91,5	91,9	89,5

CQS Q values

Q1	Q2	Q3	Q4	Q5	Q6	Q7	Q8	Q9	Q10	Q11	Q12	Q13	Q14	Q15
97,2	95,4	94,7	95,2	90,6	88,3	93,3	97,7	96,6	97,8	95,0	94,8	95,5	94,1	96,2

COLOR PARAMETERS

Color temperature	Color rendering index	Red component	Color fidelity	Color gamut	Color quality scale	Television lighting index	Color coordinate cie 1931	Color coordinate cie 1931	Color deviation from black body
CCT	CRI	CRI R9	TM30 Rf	TM30 Rg	CQS	TLCI	x	y	Δuv
3149 K	92,1	85,5	92,8	106,0	94,1	86	0,421	0,388	-0,0042

# TM30 DETAILS

**Rf 92,8**  
Fidelity index Rf

**Rg 106,0**  
Gammut index

Hue Bin	R <sub>f</sub>	Graphic shifts (%)	
		Chroma	Hue
1	94	1%	-1%
2	95	2%	-1%
3	93	2%	0%
4	96	1%	-1%
5	94	1%	3%
6	89	6%	4%
7	92	5%	1%
8	88	7%	-2%
9	93	4%	-1%
10	95	2%	-2%
11	95	2%	0%
12	88	6%	-5%
13	90	3%	-7%
14	91	3%	-5%
15	92	2%	-2%
16	89	3%	-7%

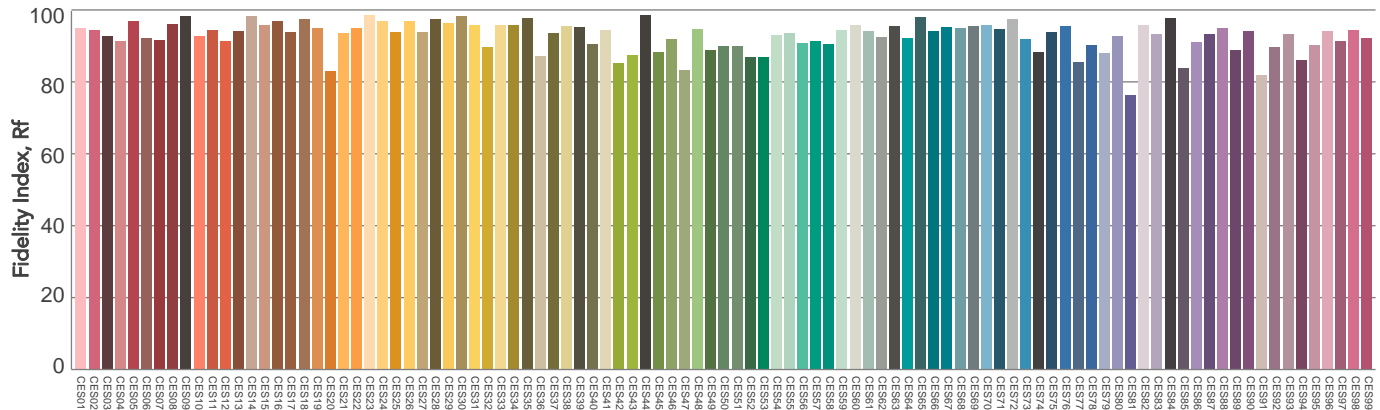
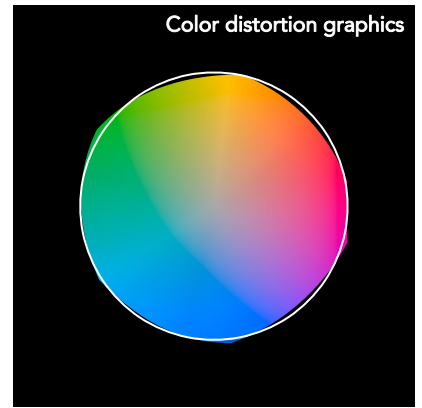
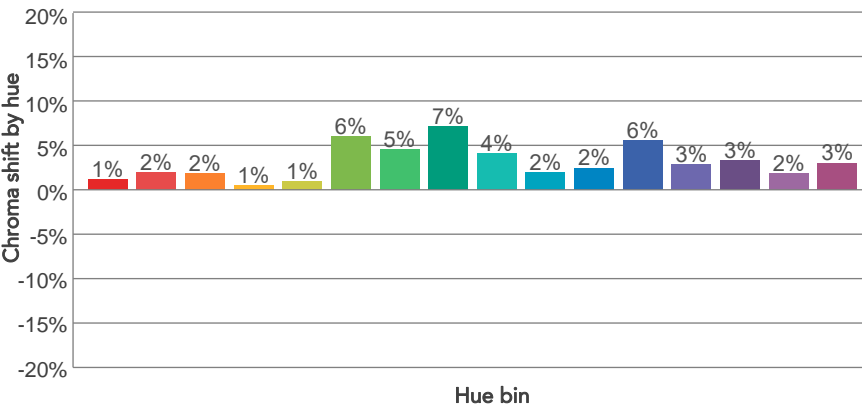
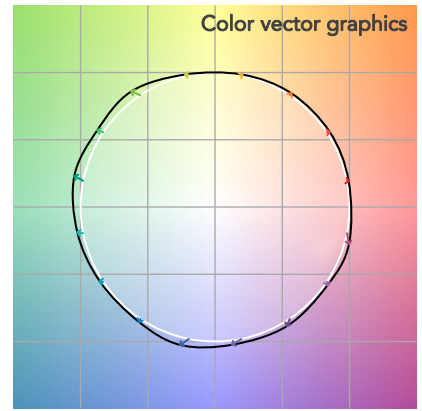
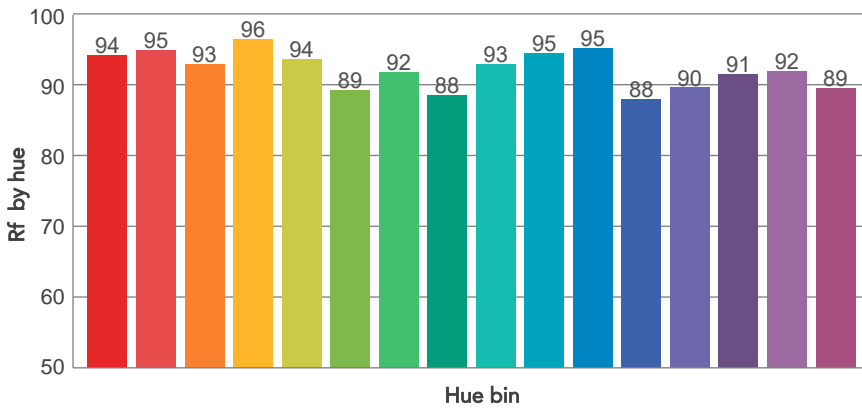
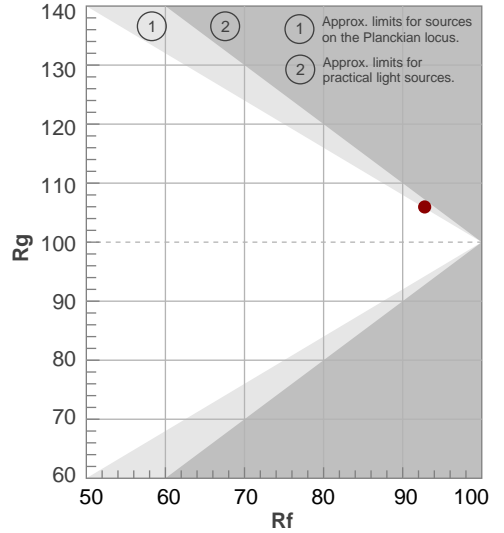

# BEAM DETAILS



Beam angle 50%	Field angle 10%	Cut off angle 2,5%	Intensity ratio in 120° cone	Intensity ratio in 90° cone
20,6°	37,2°	45,4°	100,0%	100,0%

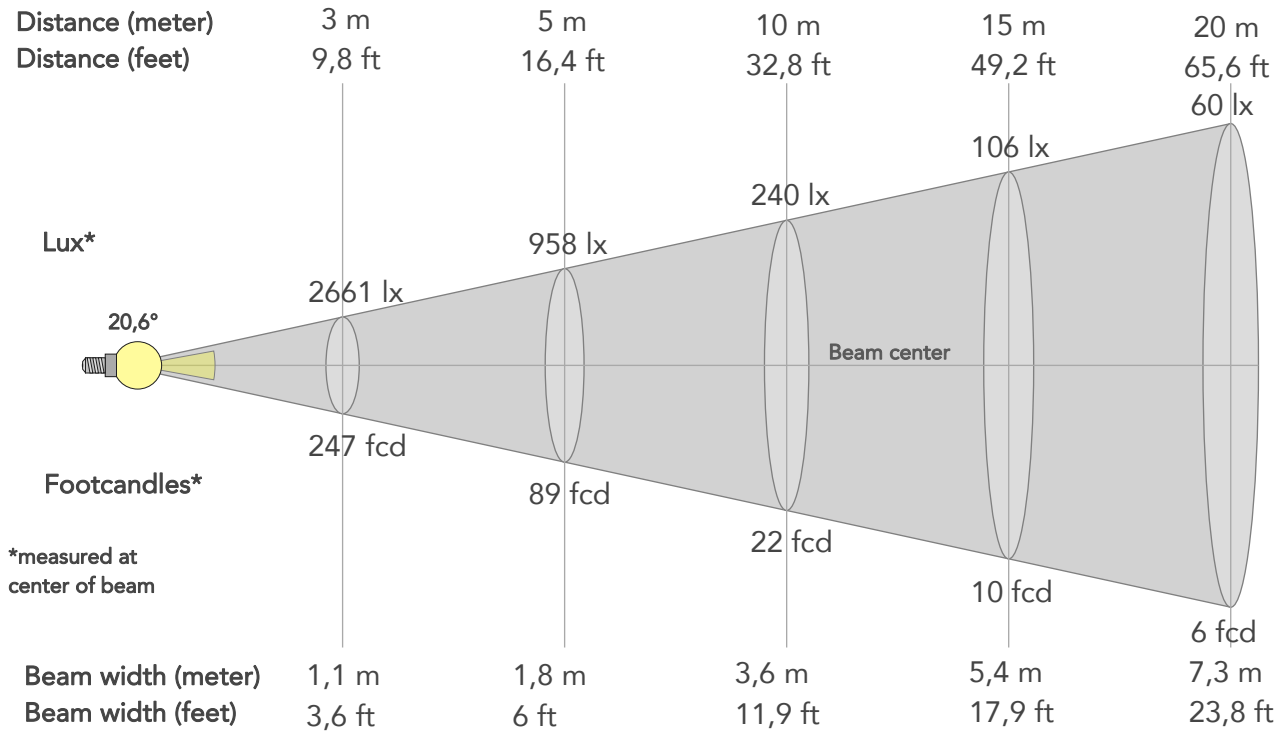

## BEAM INTENSITIES AND WIDTHS

Distance	1m	2m	3m	4m	5m	7,5m	10m	15m	20m	25m	30m	40m	50m
Distance	3,3ft	6,6ft	9,8ft	13,1ft	16,4ft	24,6ft	32,8ft	49,2ft	65,6ft	82ft	98,4ft	131,2ft	164ft
Lux	23952lx	5988lx	2661lx	1497lx	958lx	426lx	240lx	106lx	60lx	38lx	27lx	15lx	10lx
Footcand.	2225fcd	556fcd	247fcd	139fcd	89fcd	40fcd	22fcd	10fcd	6fcd	4fcd	2fcd	1fcd	1fcd
Beam wid.	0,4m	0,7m	1,1m	1,5m	1,8m	2,7m	3,6m	5,4m	7,3m	9,1m	10,9m	14,5m	18,1m
Beam wid.	1,2ft	2,4ft	3,6ft	4,8ft	6ft	8,9ft	11,9ft	17,9ft	23,8ft	29,8ft	35,7ft	47,6ft	59,5ft

## LINEAR DISTRIBUTION DIAGRAM

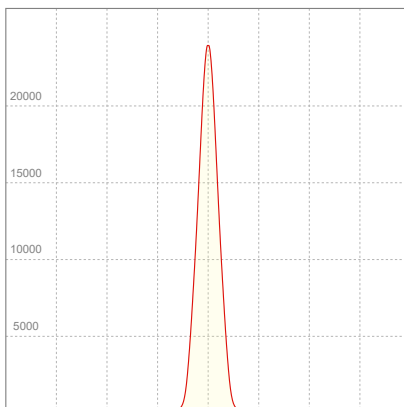

## ELECTRICAL SPECIFICATIONS

Input voltage	Input current	Input power	Effeciency
227V	0,860A	193,7W	18lm/W

## ISO CANDELA DIAGRAM

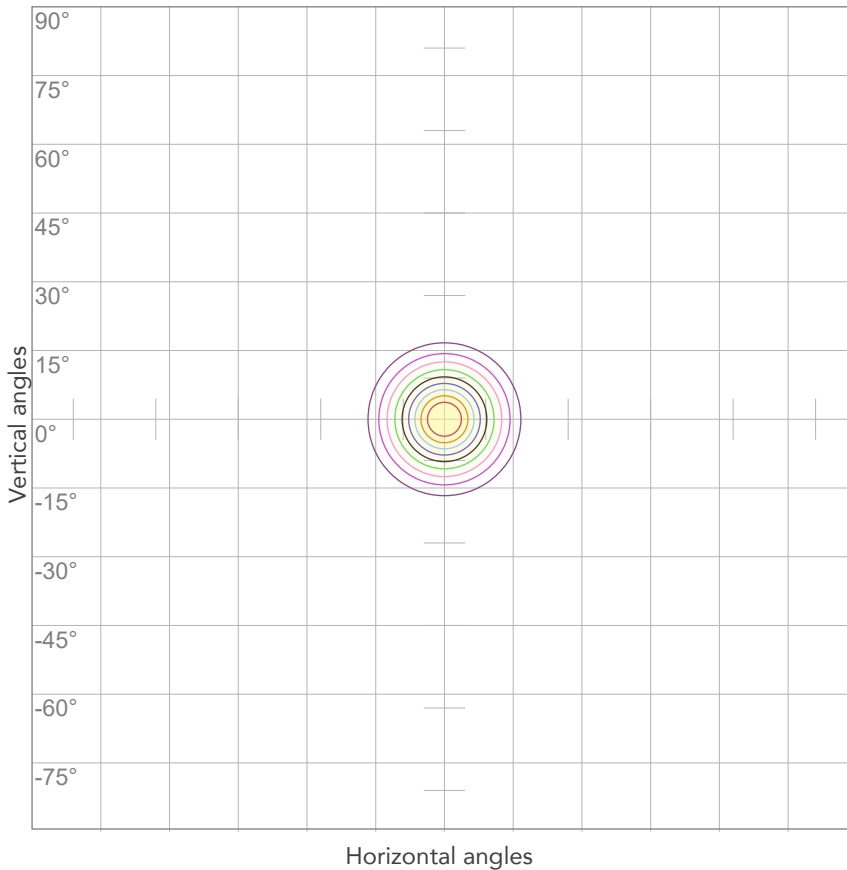

10%	2395 cd
20%	4790 cd
30%	7186 cd
40%	9581 cd
50%	11976 cd
60%	14371 cd
70%	16766 cd
80%	19162 cd

Conditions:

Number of c-planes: 2

Candela at center: 23952 cd

## ISO LUX DIAGRAM

MH: 10,0 m

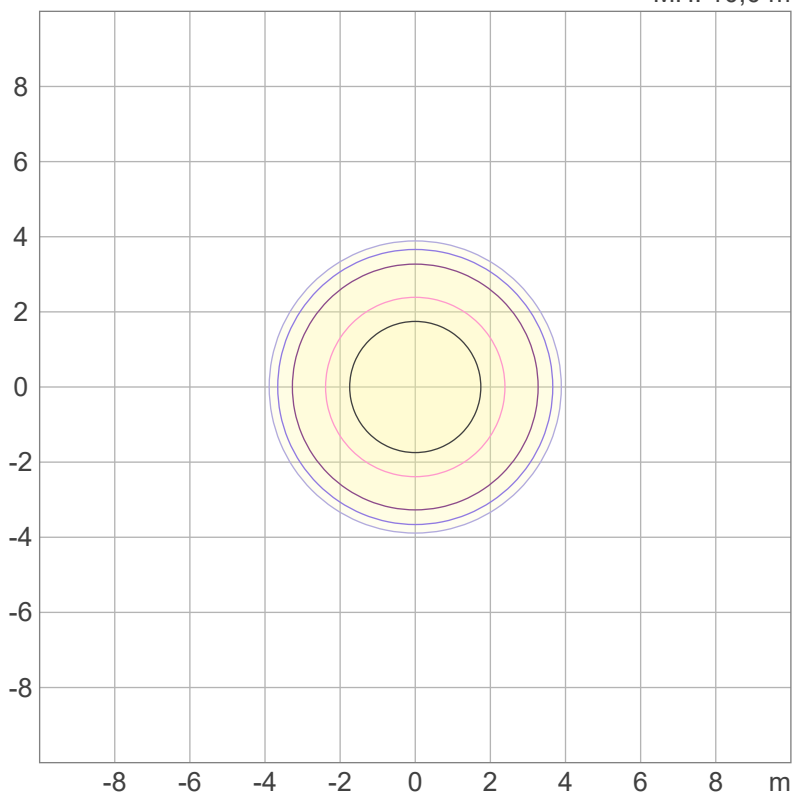

Mounting height: 10 meters (33 feet)

3%	7,19 lx
5%	12,0 lx
10%	24,0 lx
30%	71,9 lx
50%	120 lx

Conditions:

Number of c-planes: 2

Lux at center: 240 lx

*Lux distribution on a surface when lamp is mounted at 10 meters from the surface.*



Total lumen output:

1909 lm

Peak candela output:

56208 cd

Light quality:

CRI: 92,0

Color temperature:

3197 K

**PRODUCT NAME:**

ECLFRCTPS

**MEASURAMENT CONDITIONS:**

Beam angle:

Min Zoom

Target:

3200K - HB

Operator:

Salvatore Giglio

Date and time:

02/10/2023 17:18:33

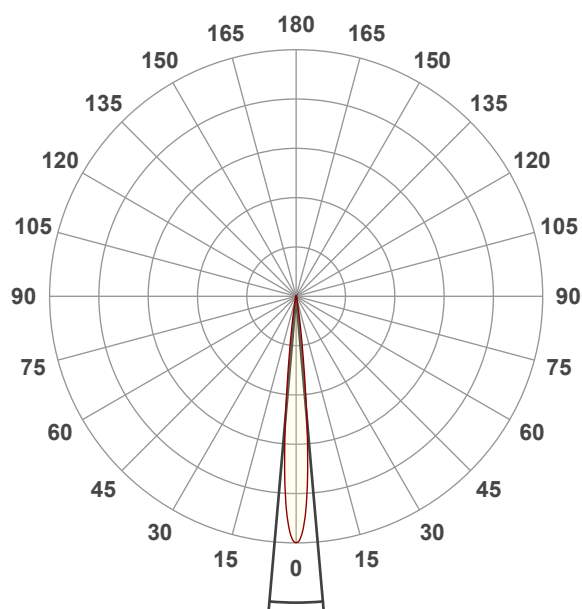

Beam angle 50%: 10°

Field angle 10%: 16,9°

Cut off angle 2.5%: 23°

Spectra

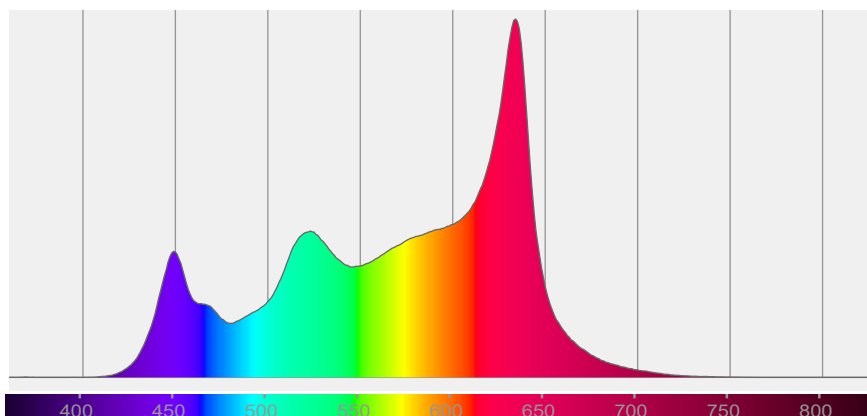

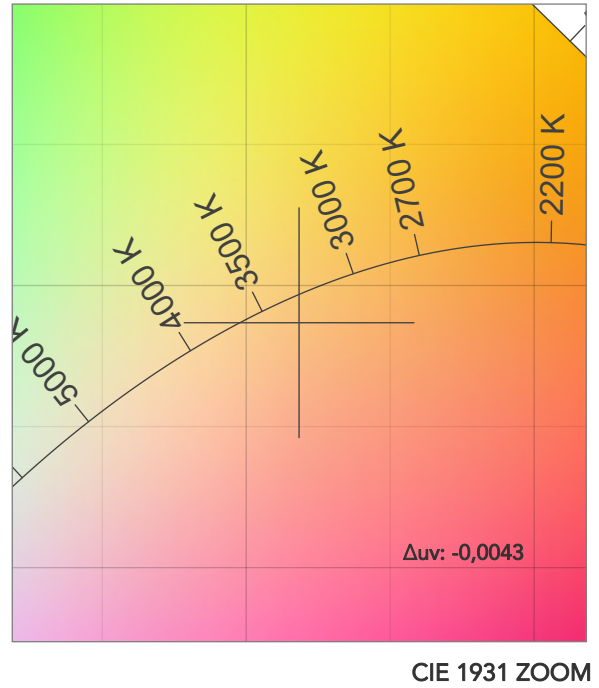
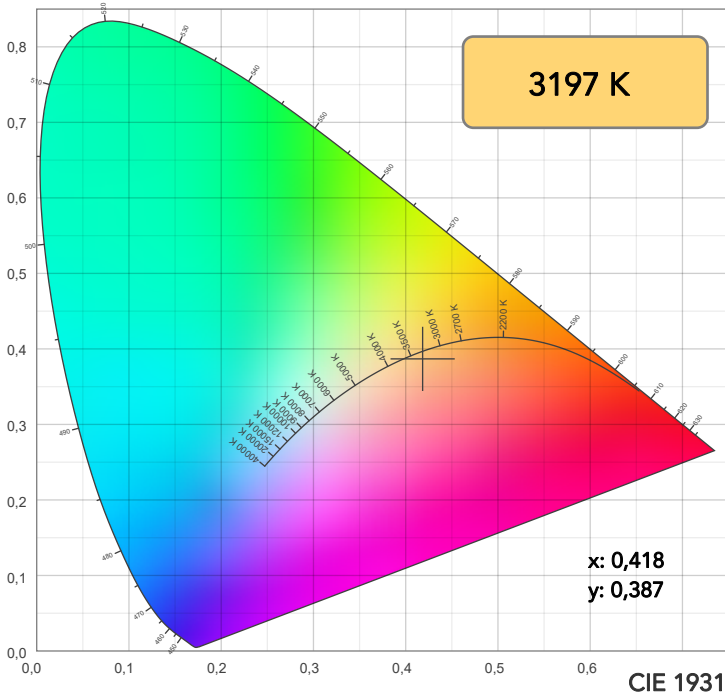

TM30: 92,8

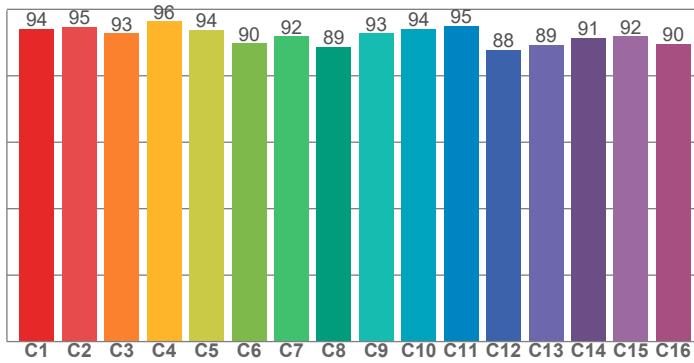

CRI: 92,0 (R1-R8)

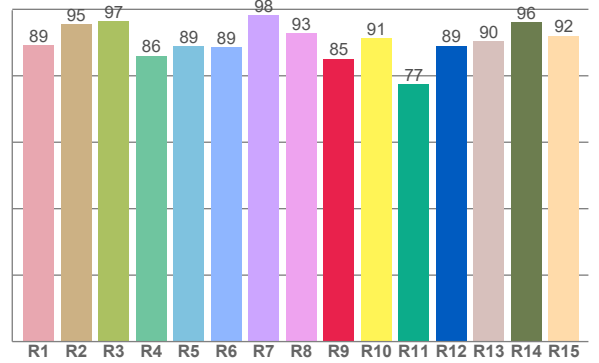

CRI R values, only R1-R8 are used to calculate final CRI value

R1	R2	R3	R4	R5	R6	R7	R8	R9	R10	R11	R12	R13	R14	R15
89,2	95,5	96,5	86,0	88,9	88,7	98,3	92,7	85,1	91,3	77,5	89,1	90,4	96,1	92,1

TM30 C values, 16 binned values out of total of 99 C values

C1	C2	C3	C4	C5	C6	C7	C8	C9	C10	C11	C12	C13	C14	C15	C16
94,1	94,7	92,7	96,3	93,9	89,7	91,8	88,7	92,8	94,1	95,0	87,8	89,3	91,4	91,9	89,6

CQS Q values

Q1	Q2	Q3	Q4	Q5	Q6	Q7	Q8	Q9	Q10	Q11	Q12	Q13	Q14	Q15
97,3	95,4	95,5	94,7	90,7	89,0	94,3	97,3	96,9	98,3	94,6	94,6	95,5	94,0	95,9

CQS: 94,3

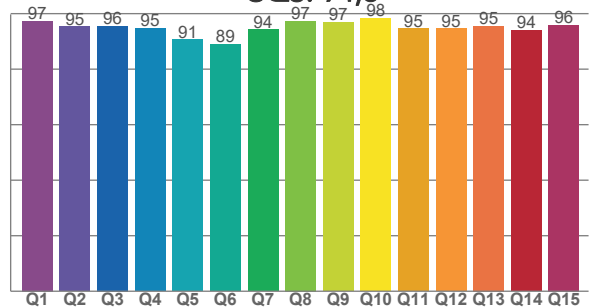

COLOR PARAMETERS

Color temperature	Color rendering index	Red component	Color fidelity	Color gamut	Color quality scale	Television lighting index	Color coordinate cie 1931	Color coordinate cie 1931	Color deviation from black body
CCT	CRI	CRI R9	TM30 Rf	TM30 Rg	CQS	TLCI	x	y	Δuv
3197 K	92,0	85,1	92,8	105,7	94,3	86	0,418	0,387	-0,0043

# TM30 DETAILS

**Rf 92,8**  
Fidelity index Rf

**Rg 105,7**  
Gammut index

Hue Bin	R <sub>f</sub>	Graphic shifts (%)	
		Chroma	Hue
1	94	1%	0%
2	95	2%	-1%
3	93	2%	-1%
4	96	0%	-1%
5	94	0%	2%
6	90	6%	4%
7	92	4%	2%
8	89	7%	-2%
9	93	4%	-1%
10	94	2%	-2%
11	95	3%	0%
12	88	6%	-6%
13	89	3%	-8%
14	91	3%	-5%
15	92	2%	-2%
16	90	3%	-7%

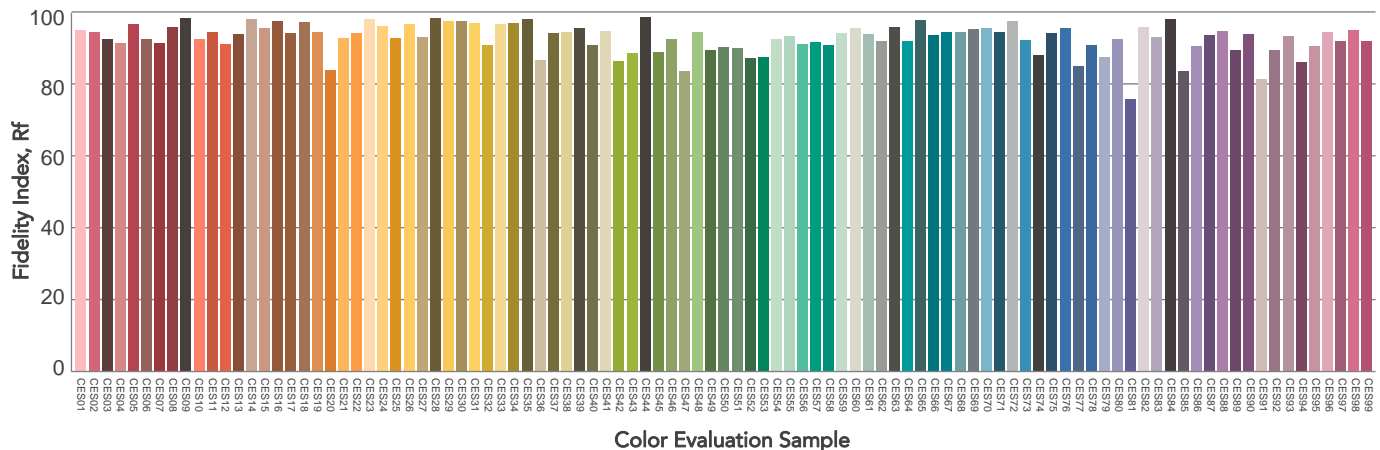
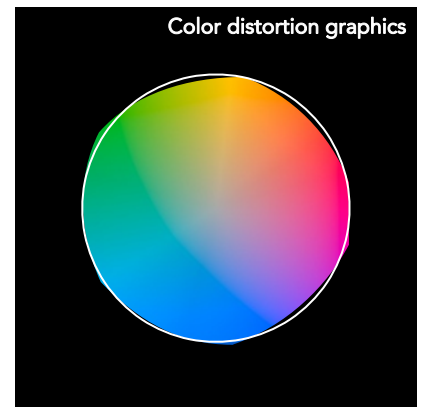
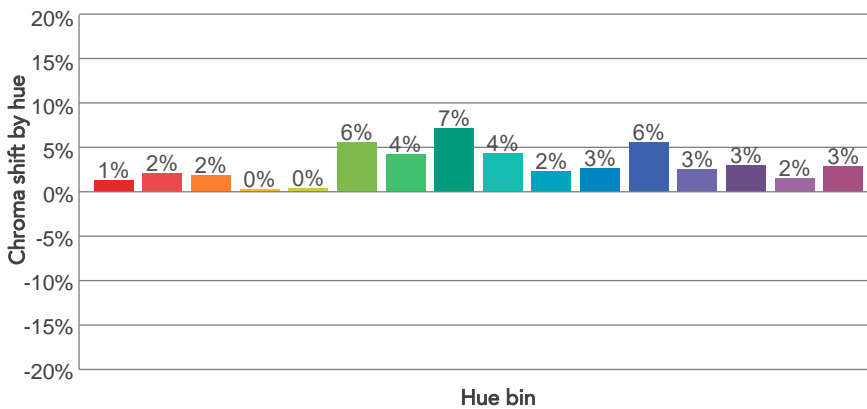
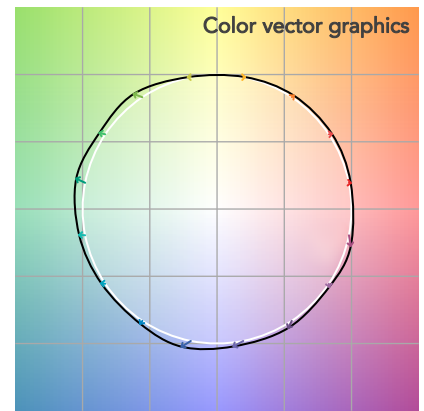
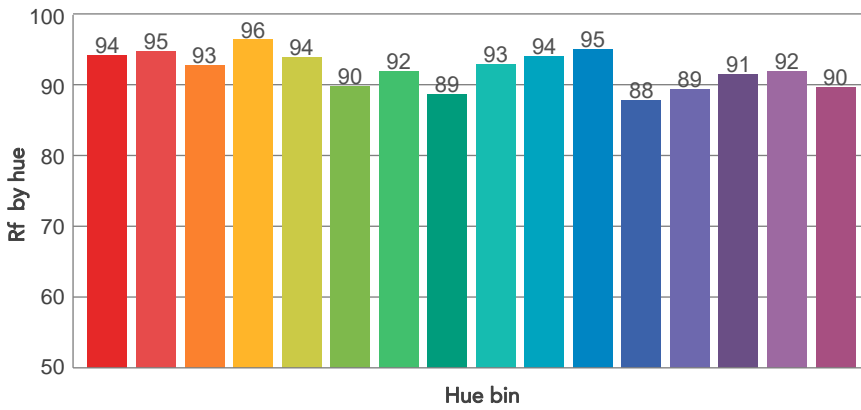
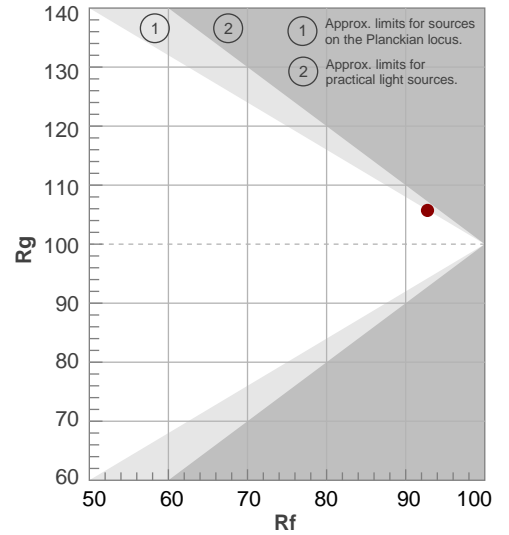

# BEAM DETAILS



Beam angle 50%	Field angle 10%	Cut off angle 2,5%	Intensity ratio in 120° cone	Intensity ratio in 90° cone
10°	16,9°	23°	100,0%	100,0%

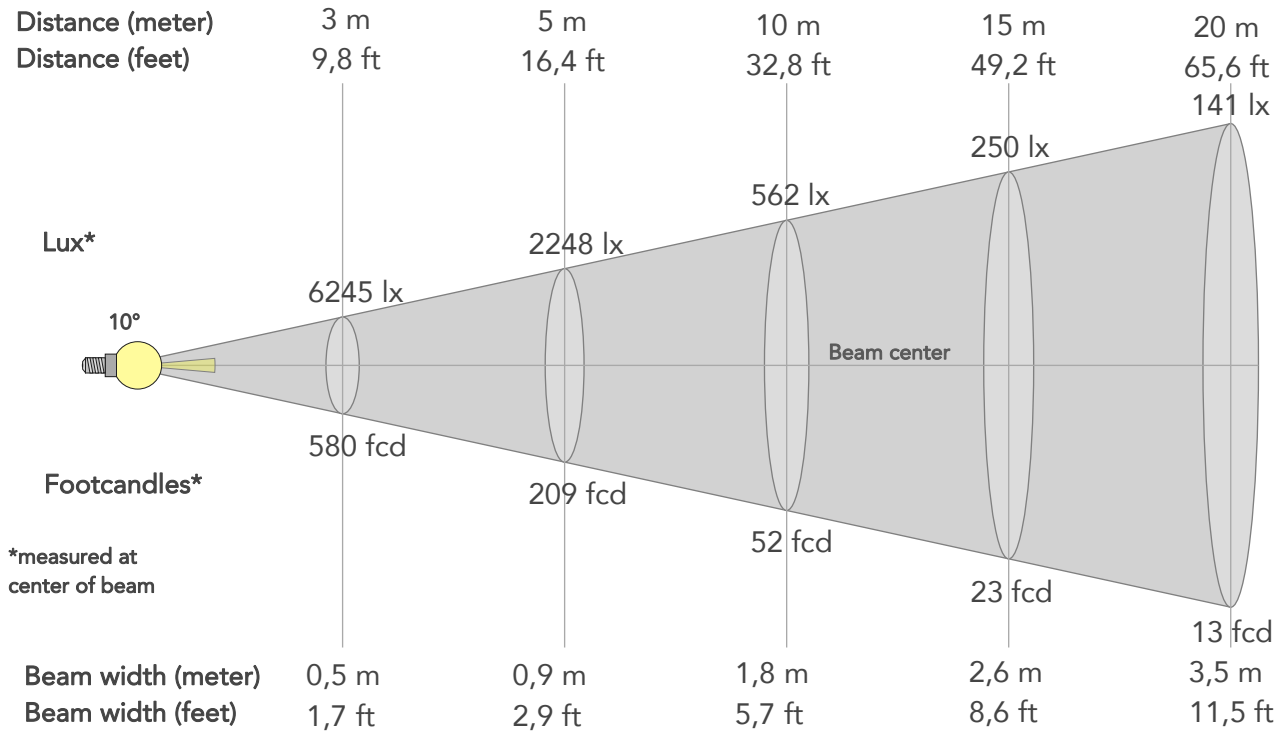

## BEAM INTENSITIES AND WIDTHS

Distance	1m	2m	3m	4m	5m	7,5m	10m	15m	20m	25m	30m	40m	50m
Distance	3,3ft	6,6ft	9,8ft	13,1ft	16,4ft	24,6ft	32,8ft	49,2ft	65,6ft	82ft	98,4ft	131,2ft	164ft
Lux	56208lx	14052lx	6245lx	3513lx	2248lx	999lx	562lx	250lx	141lx	90lx	62lx	35lx	22lx
Footcand.	5222fcd	1305fcd	580fcd	326fcd	209fcd	93fcd	52fcd	23fcd	13fcd	8fcd	6fcd	3fcd	2fcd
Beam wid.	0,2m	0,4m	0,5m	0,7m	0,9m	1,3m	1,8m	2,6m	3,5m	4,4m	5,3m	7m	8,8m
Beam wid.	0,6ft	1,2ft	1,7ft	2,3ft	2,9ft	4,3ft	5,7ft	8,6ft	11,5ft	14,4ft	17,2ft	23ft	28,7ft

## LINEAR DISTRIBUTION DIAGRAM

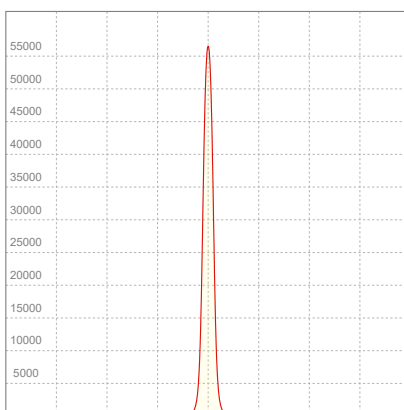

## ELECTRICAL SPECIFICATIONS

Input voltage	Input current	Input power	Effeciency
226V	0,863A	194,1W	10lm/W



## ISO CANDELA DIAGRAM

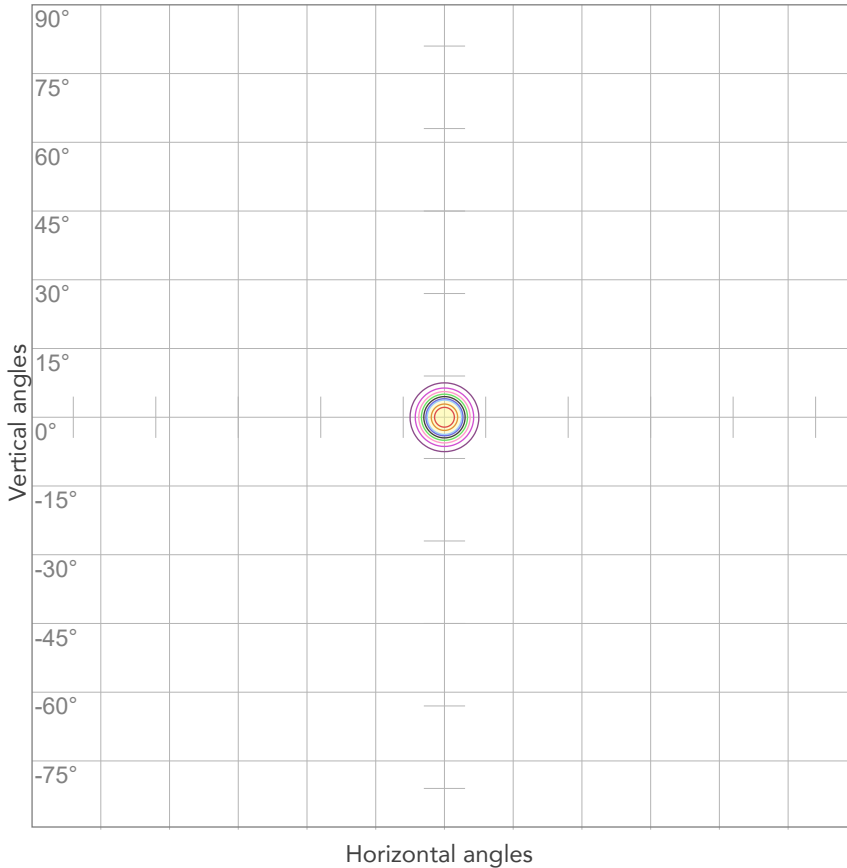

10%	5621 cd
20%	11242 cd
30%	16862 cd
40%	22483 cd
50%	28104 cd
60%	33725 cd
70%	39345 cd
80%	44966 cd

Conditions:

Number of c-planes: 2

Candela at center: 56208 cd

## ISO LUX DIAGRAM

MH: 10,0 m

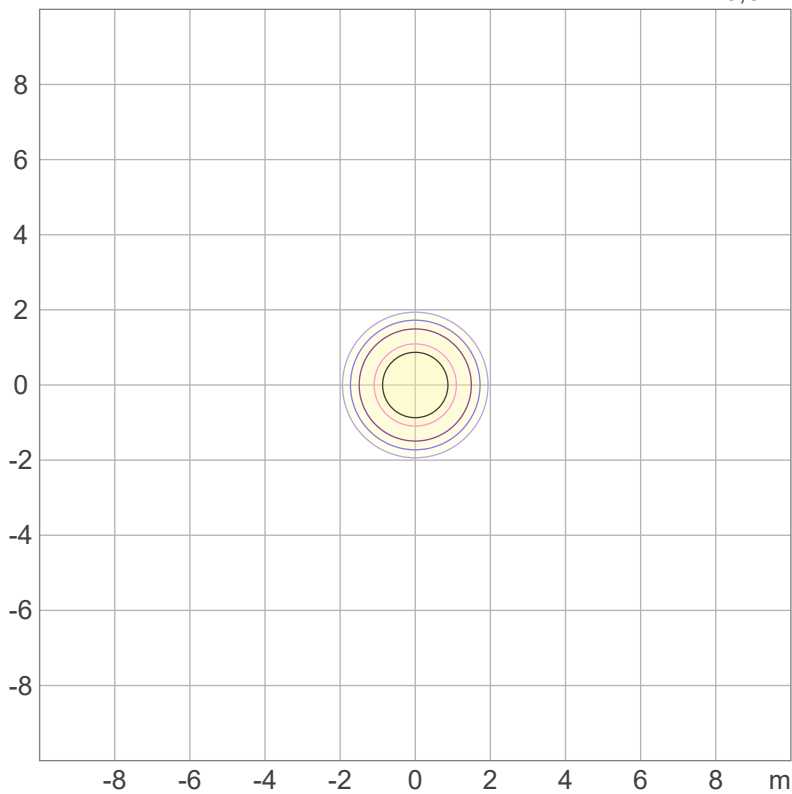

Mounting height: 10 meters (33 feet)

3%	16,9 lx
5%	28,1 lx
10%	56,2 lx
30%	169 lx
50%	281 lx

Conditions:

Number of c-planes: 2

Lux at center: 562 lx

*Lux distribution on a surface when lamp is mounted at 10 meters from the surface.*



Total lumen output:

4795 lm

Peak candela output:

7162 cd

Light quality:

CRI: 95,3

Color temperature:

3957 K

PRODUCT NAME:

ECLFRCTPS

MEASURAMENT CONDITIONS:

Beam angle:

Max Zoom

Target:

4000K - HB

Operator:

Salvatore Giglio

Date and time:

02/10/2023 16:57:06

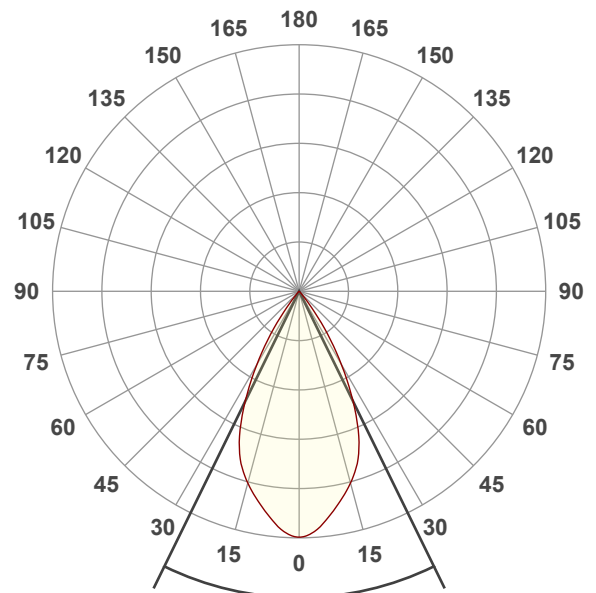

Beam angle 50%: 52,2°

Field angle 10%: 73,8°

Cut off angle 2.5%: 81°

Spectra

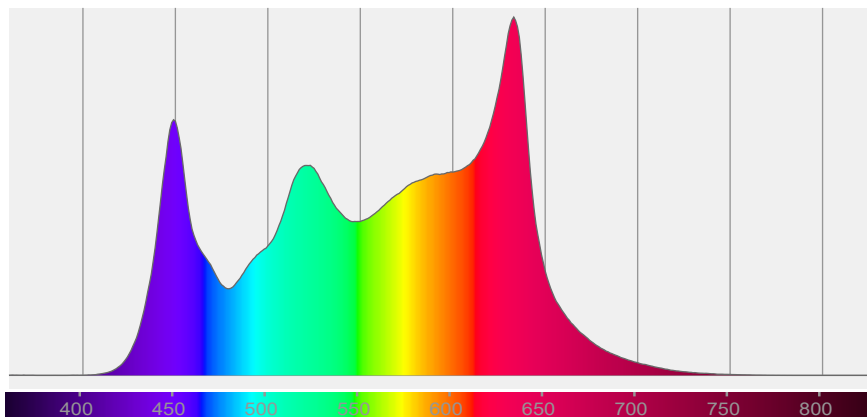

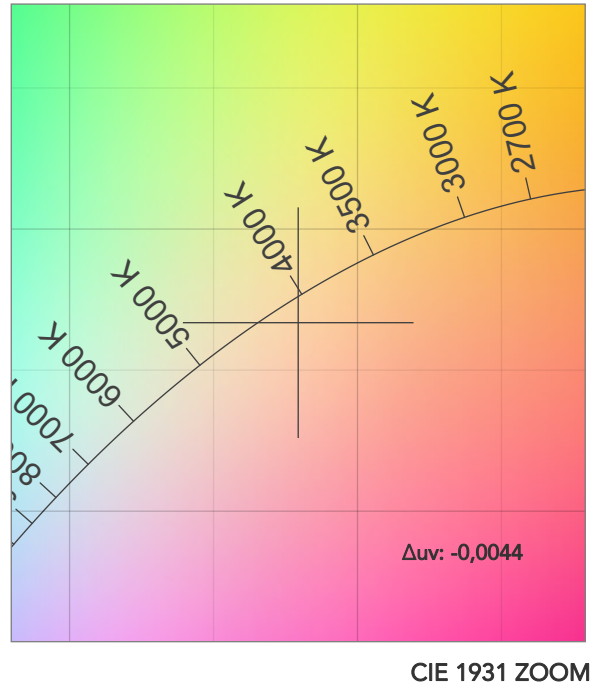
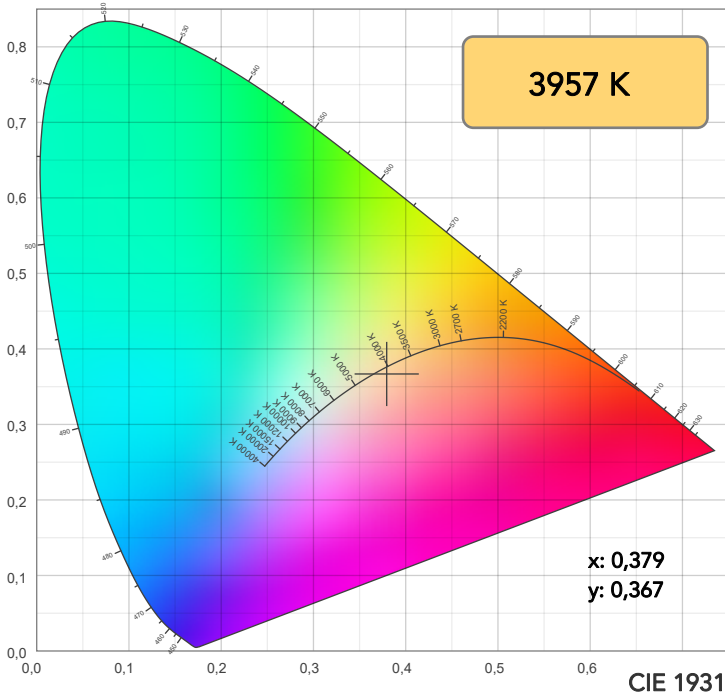

TM30: 93,7

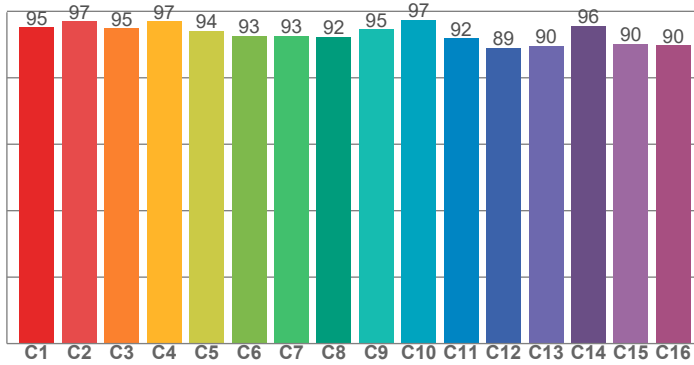

CRI: 95,3 (R1-R8)

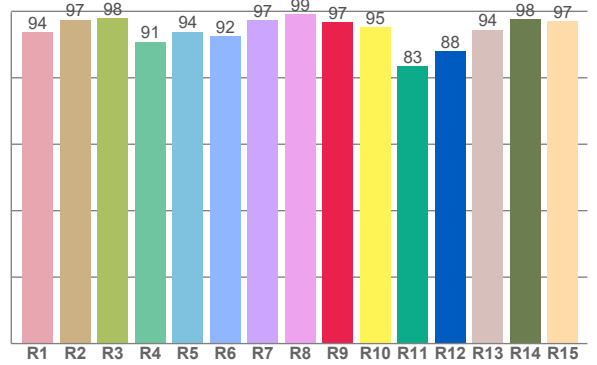

CRI R values, only R1-R8 are used to calculate final CRI value

R1	R2	R3	R4	R5	R6	R7	R8	R9	R10	R11	R12	R13	R14	R15
93,8	97,4	97,8	90,8	93,9	92,5	97,3	99,0	96,7	95,2	83,5	87,9	94,5	97,5	97,1

TM30 C values, 16 binned values out of total of 99 C values

C1	C2	C3	C4	C5	C6	C7	C8	C9	C10	C11	C12	C13	C14	C15	C16
95,2	97,0	94,9	97,0	94,2	92,7	92,7	92,4	94,6	97,4	91,9	89,0	89,6	95,6	90,2	89,8

CQS Q values

Q1	Q2	Q3	Q4	Q5	Q6	Q7	Q8	Q9	Q10	Q11	Q12	Q13	Q14	Q15
96,1	98,1	93,1	98,8	95,8	93,4	97,0	99,2	98,5	98,5	98,3	99,2	99,2	96,4	96,9

CQS: 96,6

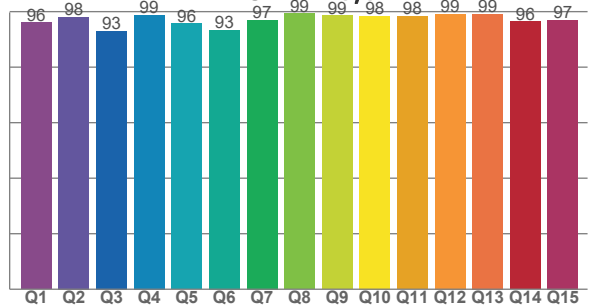

COLOR PARAMETERS

Color temperature	Color rendering index	Red component	Color fidelity	Color gamut	Color quality scale	Television lighting index	Color coordinate cie 1931	Color coordinate cie 1931	Color deviation from black body
CCT	CRI	CRI R9	TM30 Rf	TM30 Rg	CQS	TLCI	x	y	$\Delta uv$
3957 K	95,3	96,7	93,7	103,8	96,6	88	0,379	0,367	-0,0044

# TM30 DETAILS



**Rf 93,7**  
Fidelity index Rf

**Rg 103,8**  
Gammut index

Hue Bin	R <sub>f</sub>	Graphic shifts (%)	
		Chroma	Hue
1	95	-1%	0%
2	97	1%	0%
3	95	1%	1%
4	97	0%	-1%
5	94	-1%	1%
6	93	4%	3%
7	93	4%	2%
8	92	3%	1%
9	95	3%	1%
10	97	1%	0%
11	92	4%	3%
12	89	4%	0%
13	90	4%	-6%
14	96	2%	1%
15	90	2%	-6%
16	90	2%	-6%

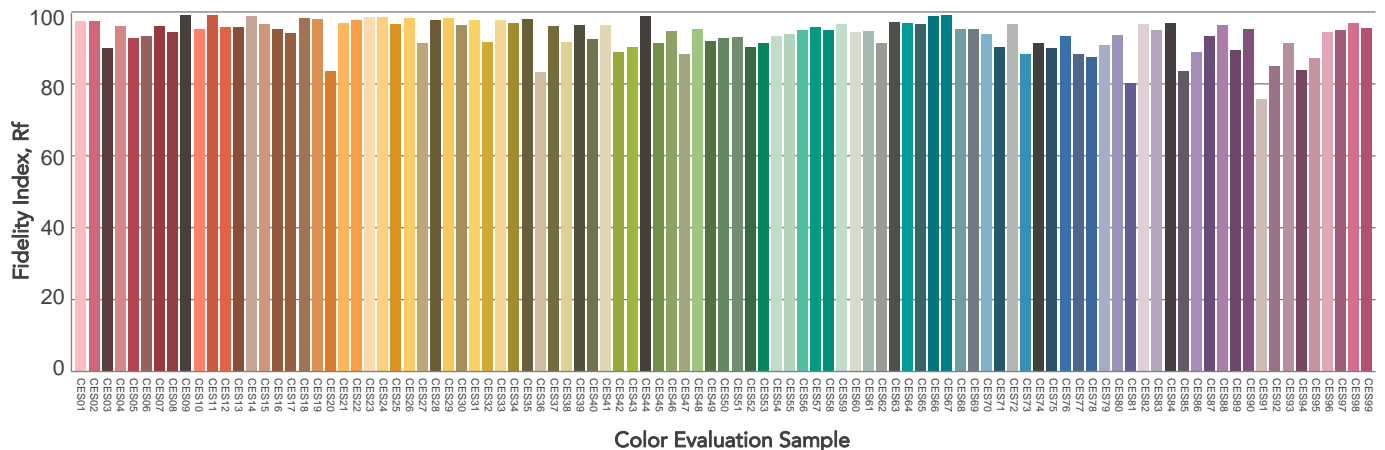
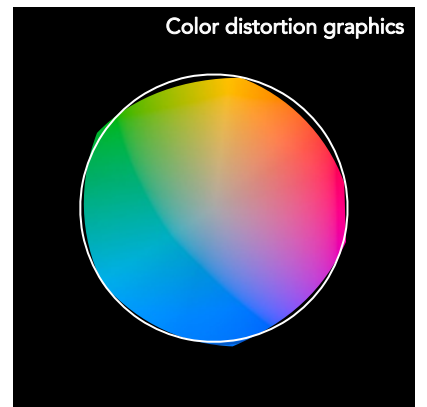
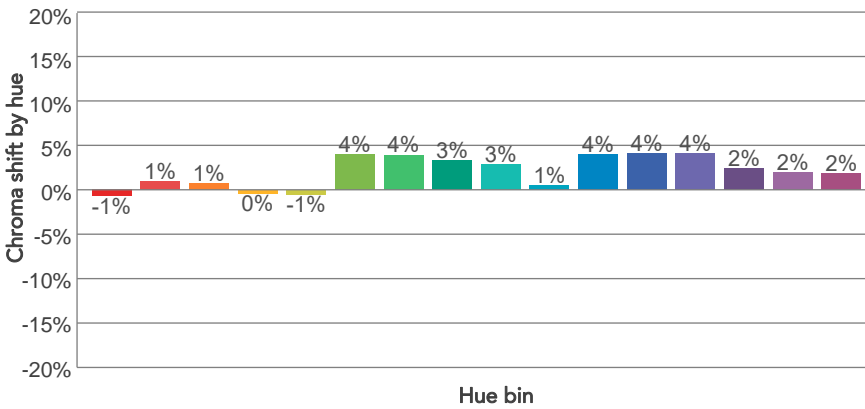
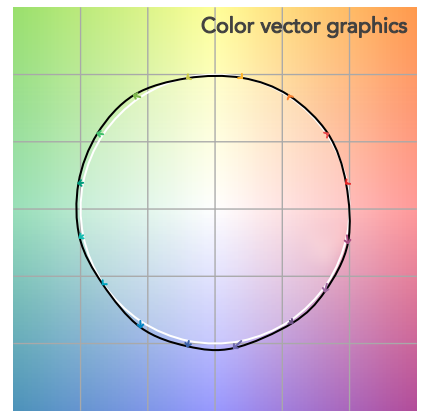
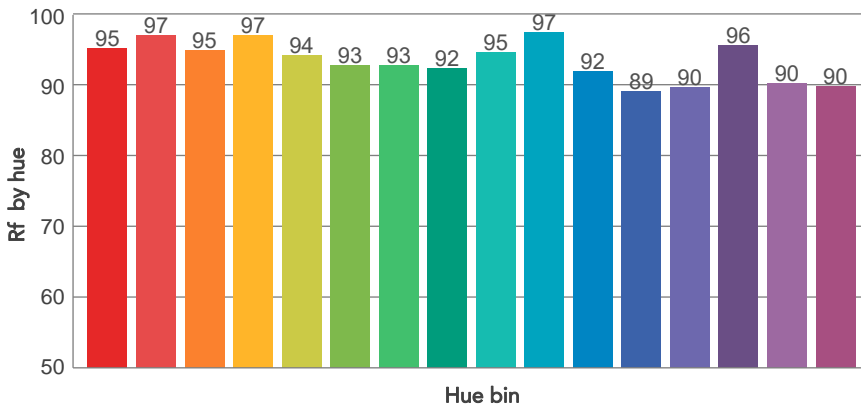
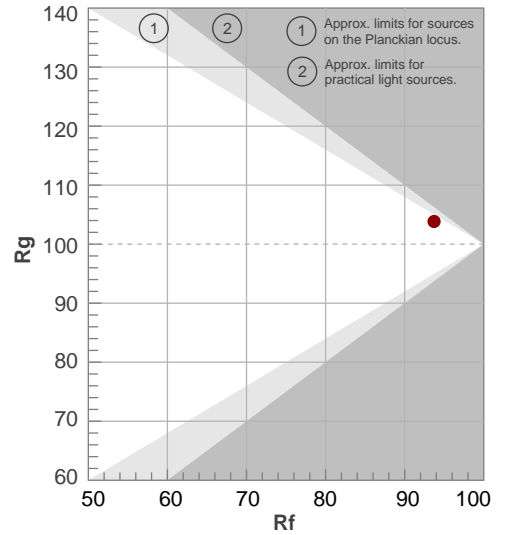

# BEAM DETAILS



Beam angle 50%	Field angle 10%	Cut off angle 2,5%	Intensity ratio in 120° cone	Intensity ratio in 90° cone
52,2°	73,8°	81°	100,0%	99,6%

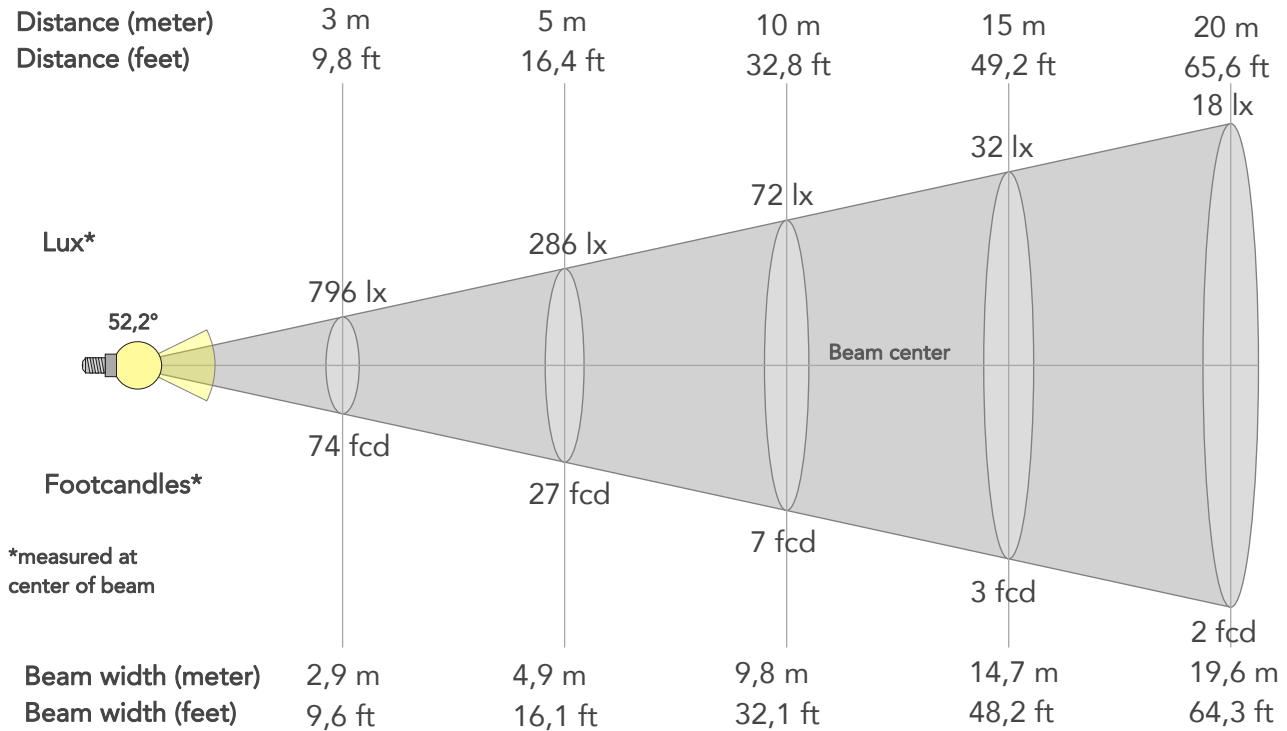

## BEAM INTENSITIES AND WIDTHS

Distance	1m	2m	3m	4m	5m	7,5m	10m	15m	20m	25m	30m	40m	50m
Distance	3,3ft	6,6ft	9,8ft	13,1ft	16,4ft	24,6ft	32,8ft	49,2ft	65,6ft	82ft	98,4ft	131,2ft	164ft
Lux	7162lx	1791lx	796lx	448lx	286lx	127lx	72lx	32lx	18lx	11lx	8lx	4lx	3lx
Footcand.	665fcd	166fcd	74fcd	42fcd	27fcd	12fcd	7fcd	3fcd	2fcd	1fcd	1fcd	0fcd	0fcd
Beam wid.	1m	2m	2,9m	3,9m	4,9m	7,3m	9,8m	14,7m	19,6m	24,5m	29,4m	39,2m	49m
Beam wid.	3,2ft	6,5ft	9,6ft	12,8ft	16,1ft	24,1ft	32,1ft	48,2ft	64,3ft	80,4ft	96,4ft	128,6ft	160,7ft

## LINEAR DISTRIBUTION DIAGRAM

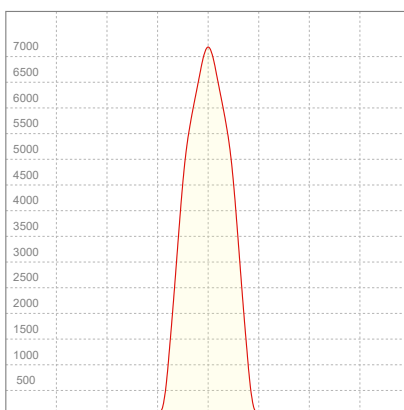

## ELECTRICAL SPECIFICATIONS

Input voltage	Input current	Input power	Effeciency
227V	0,864A	194,9W	25lm/W

## ISO CANDELA DIAGRAM

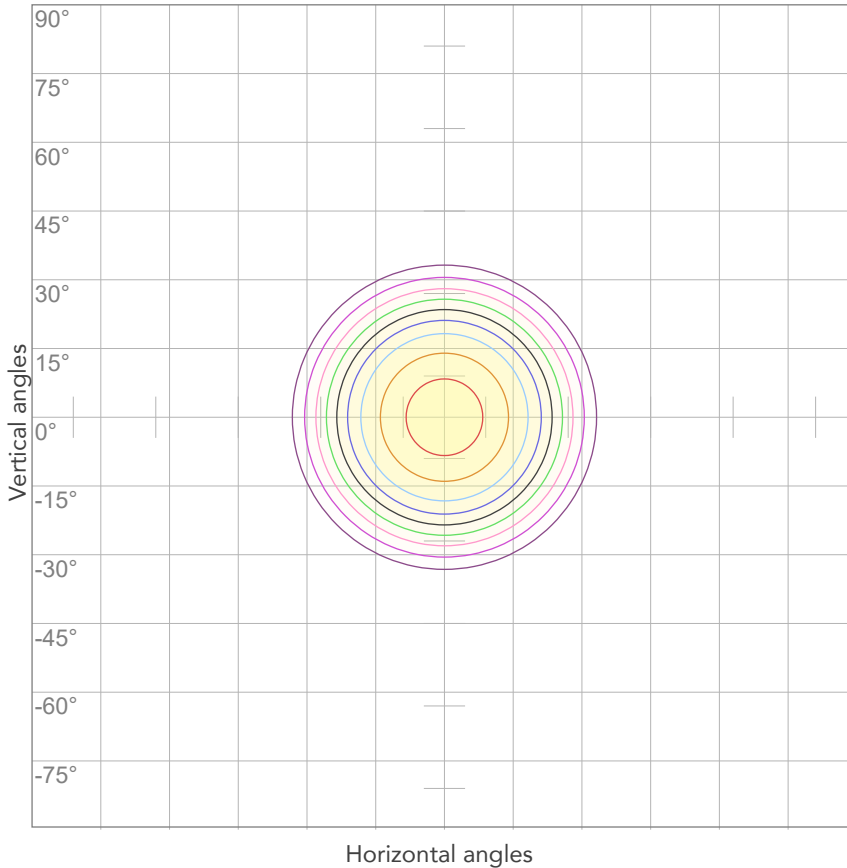

10%	716 cd
20%	1432 cd
30%	2149 cd
40%	2865 cd
50%	3581 cd
60%	4297 cd
70%	5013 cd
80%	5730 cd

Conditions:

Number of c-planes: 2

Candela at center: 7162 cd

## ISO LUX DIAGRAM

MH: 10,0 m

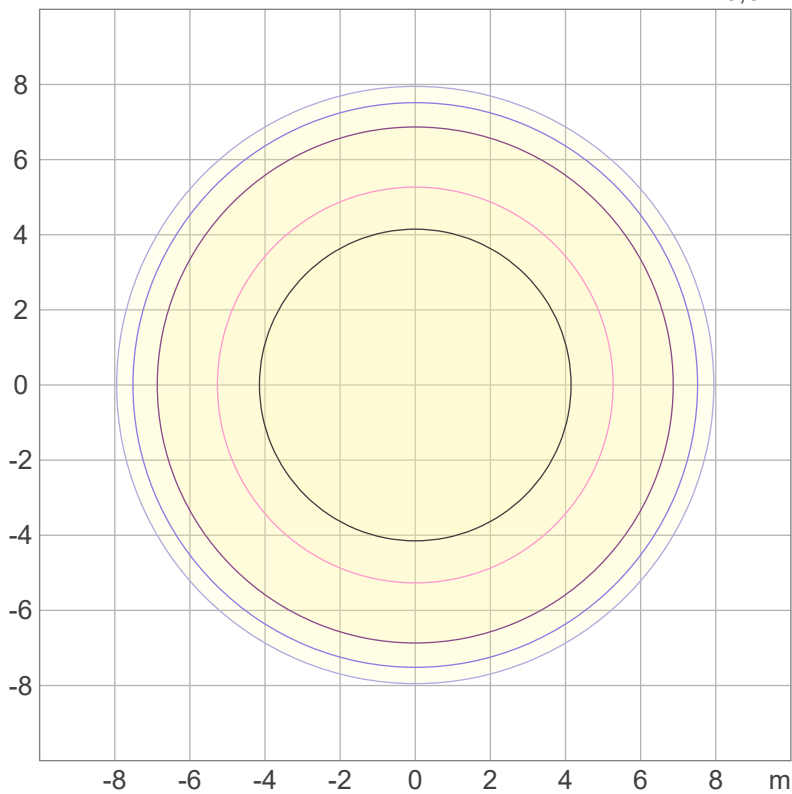

Mounting height: 10 meters (33 feet)

3%	2,15 lx
5%	3,58 lx
10%	7,16 lx
30%	21,5 lx
50%	35,8 lx

Conditions:

Number of c-planes: 2

Lux at center: 71,6 lx

*Lux distribution on a surface when lamp is mounted at 10 meters from the surface.*



Total lumen output:

3520 lm

Peak candela output:

23723 cd

Light quality:

CRI: 95,4

Color temperature:

3961 K

PRODUCT NAME:

ECLFRCTPS

MEASURAMENT CONDITIONS:

Beam angle:

Med Zoom

Target:

4000K - HB

Operator:

Salvatore Giglio

Date and time:

02/10/2023 17:10:05

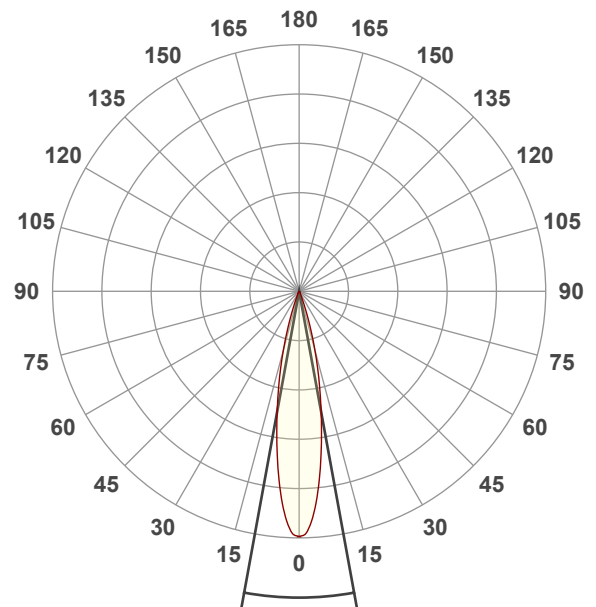

Spectra

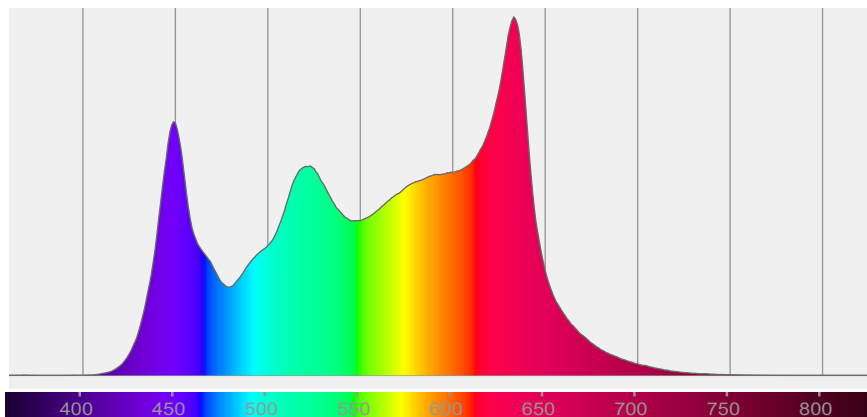

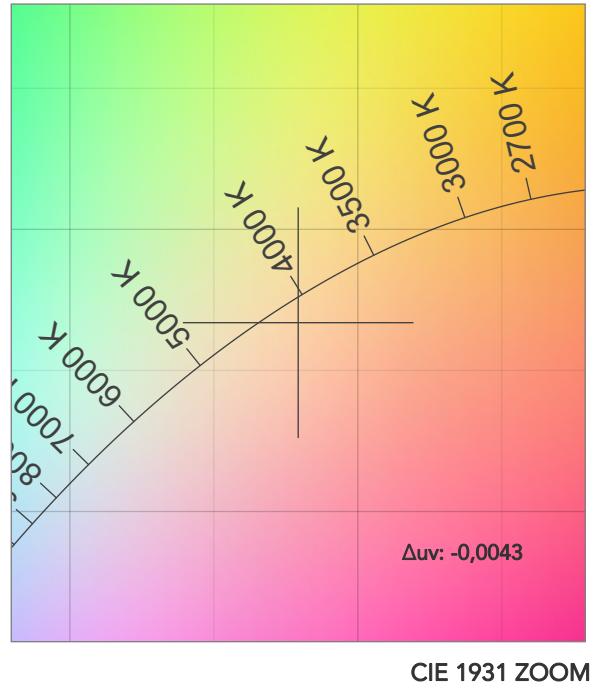
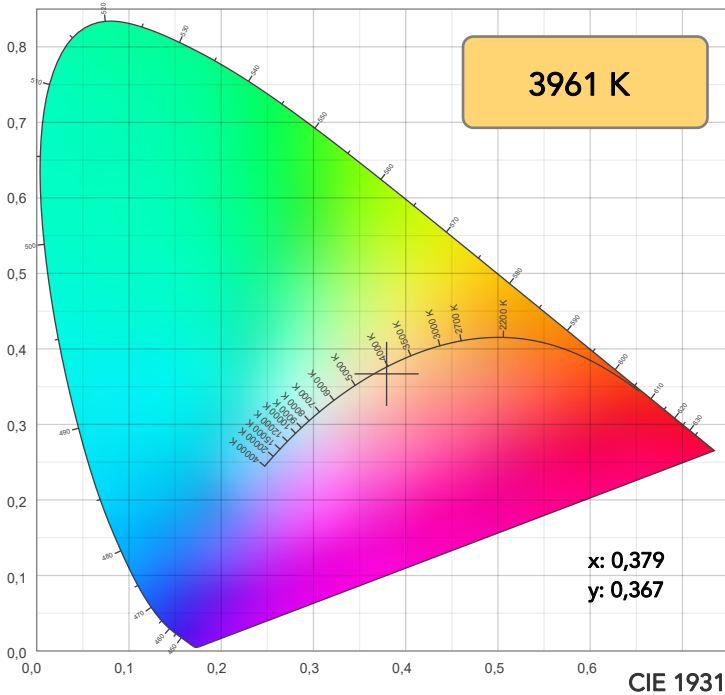

TM30: 93,8

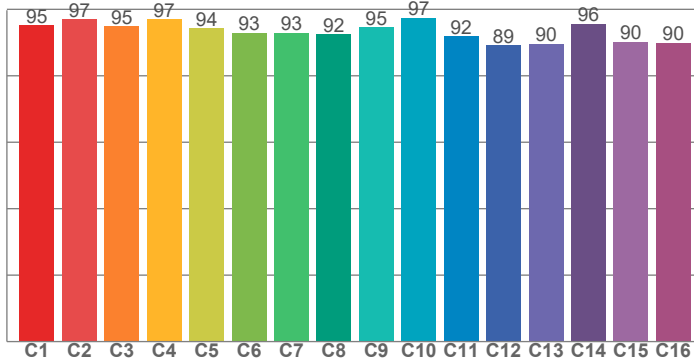

CRI: 95,4 (R1-R8)

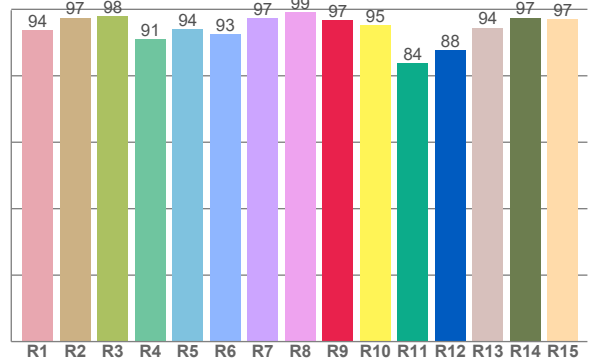

CRI R values, only R1-R8 are used to calculate final CRI value

R1	R2	R3	R4	R5	R6	R7	R8	R9	R10	R11	R12	R13	R14	R15
93,8	97,4	97,8	91,1	94,0	92,5	97,4	99,1	96,8	95,2	83,9	87,7	94,5	97,5	97,0

TM30 C values, 16 binned values out of total of 99 C values

C1	C2	C3	C4	C5	C6	C7	C8	C9	C10	C11	C12	C13	C14	C15	C16
95,2	97,0	94,9	97,0	94,3	92,9	92,8	92,5	94,6	97,4	91,9	89,1	89,6	95,6	90,2	89,8

CQS Q values

Q1	Q2	Q3	Q4	Q5	Q6	Q7	Q8	Q9	Q10	Q11	Q12	Q13	Q14	Q15
96,1	98,0	93,2	98,7	96,1	93,7	97,1	99,2	98,5	98,5	98,3	99,1	99,2	96,4	97,0

CQS: 96,7

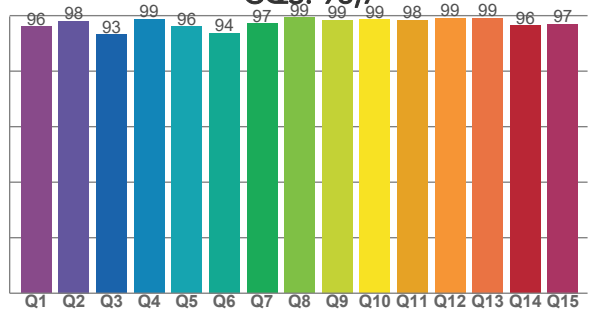

COLOR PARAMETERS

Color temperature	Color rendering index	Red component	Color fidelity	Color gamut	Color quality scale	Television lighting index	Color coordinate cie 1931	Color coordinate cie 1931	Color deviation from black body
CCT	CRI	CRI R9	TM30 Rf	TM30 Rg	CQS	TLCI	x	y	Δuv
3961 K	95,4	96,8	93,8	103,7	96,7	88	0,379	0,367	-0,0043



# TM30 DETAILS

**Rf 93,8**  
Fidelity index Rf

**Rg 103,7**  
Gammut index

Hue Bin	R <sub>f</sub>	Graphic shifts (%)	
		Chroma	Hue
1	95	-1%	0%
2	97	1%	0%
3	95	1%	1%
4	97	-1%	-1%
5	94	-1%	1%
6	93	4%	3%
7	93	4%	2%
8	92	3%	1%
9	95	3%	1%
10	97	1%	0%
11	92	4%	3%
12	89	4%	0%
13	90	4%	-7%
14	96	2%	1%
15	90	2%	-5%
16	90	2%	-5%

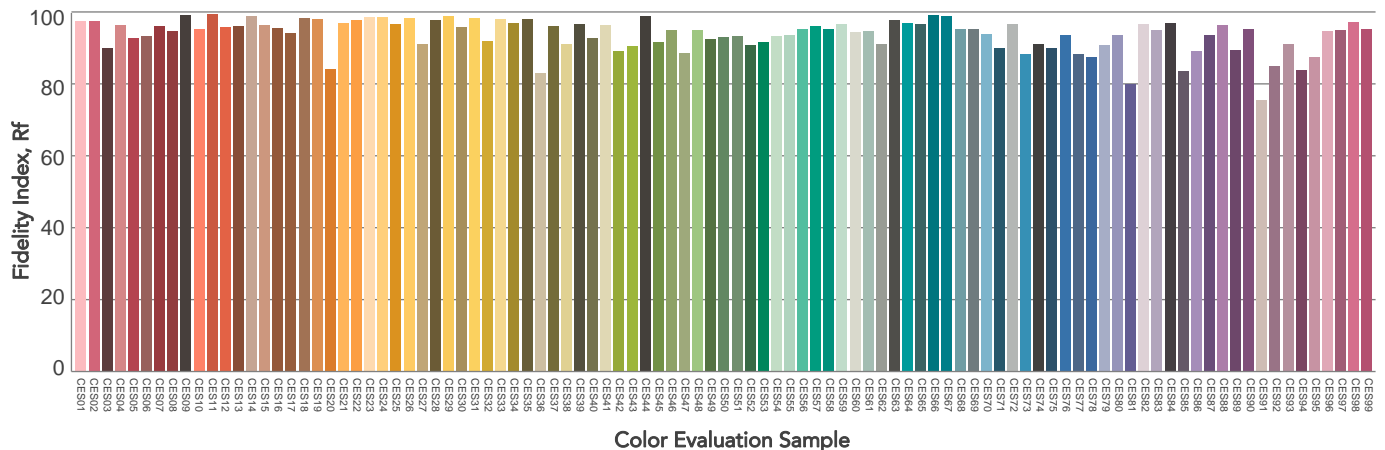
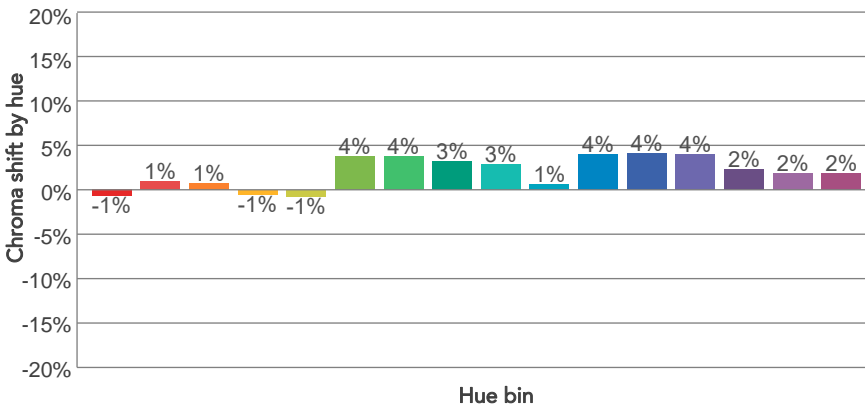
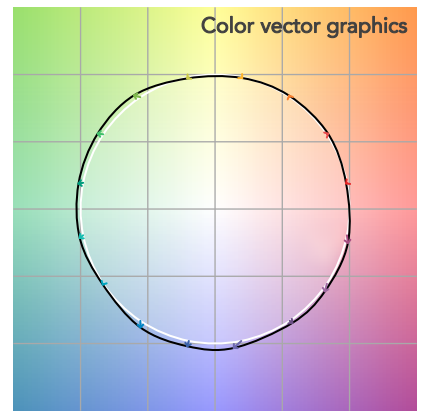
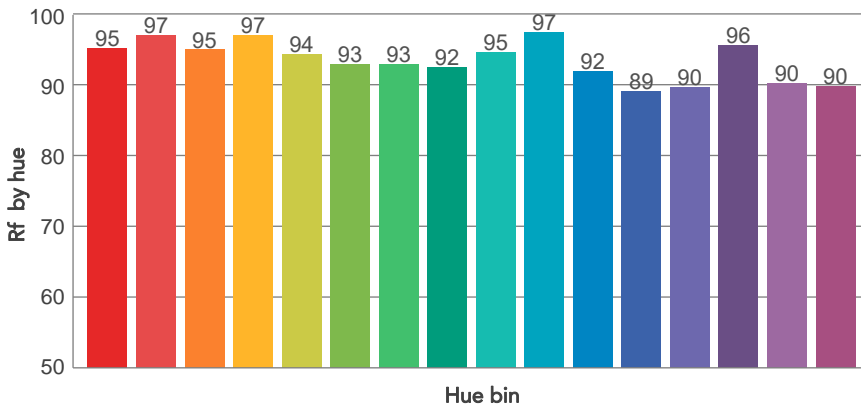
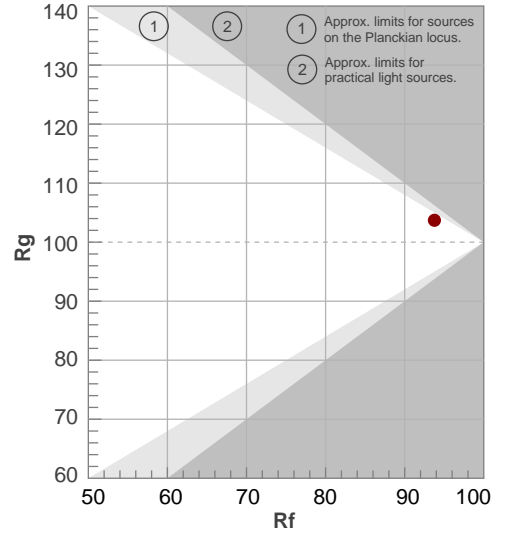

# BEAM DETAILS



Beam angle 50%	Field angle 10%	Cut off angle 2,5%	Intensity ratio in 120° cone	Intensity ratio in 90° cone
20,7°	37,4°	45,9°	100,0%	99,9%

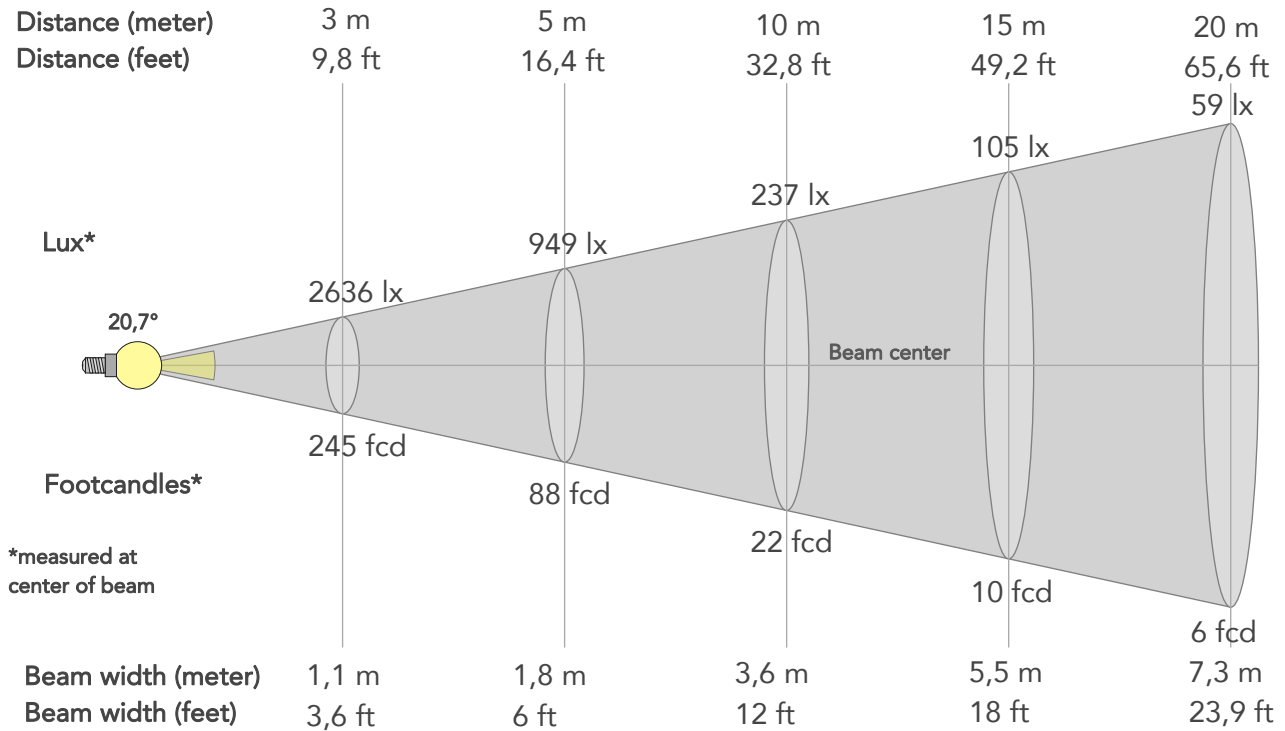

## BEAM INTENSITIES AND WIDTHS

Distance	1m	2m	3m	4m	5m	7,5m	10m	15m	20m	25m	30m	40m	50m
Distance	3,3ft	6,6ft	9,8ft	13,1ft	16,4ft	24,6ft	32,8ft	49,2ft	65,6ft	82ft	98,4ft	131,2ft	164ft
Lux	23723lx	5931lx	2636lx	1483lx	949lx	422lx	237lx	105lx	59lx	38lx	26lx	15lx	9lx
Footcand.	2204fcd	551fcd	245fcd	138fcd	88fcd	39fcd	22fcd	10fcd	6fcd	4fcd	2fcd	1fcd	1fcd
Beam wid.	0,4m	0,7m	1,1m	1,5m	1,8m	2,7m	3,6m	5,5m	7,3m	9,1m	10,9m	14,6m	18,2m
Beam wid.	1,2ft	2,4ft	3,6ft	4,8ft	6ft	9ft	12ft	18ft	23,9ft	29,9ft	35,9ft	47,9ft	59,8ft

## LINEAR DISTRIBUTION DIAGRAM

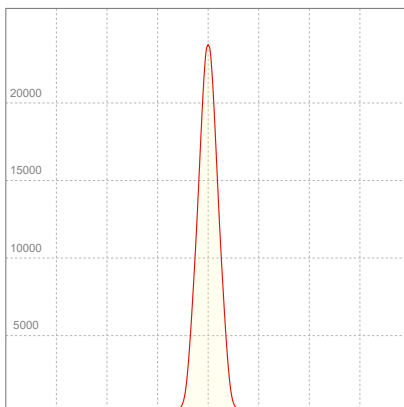

## ELECTRICAL SPECIFICATIONS

Input voltage	Input current	Input power	Effeciency
227V	0,862A	194,4W	18lm/W

## ISO CANDELA DIAGRAM

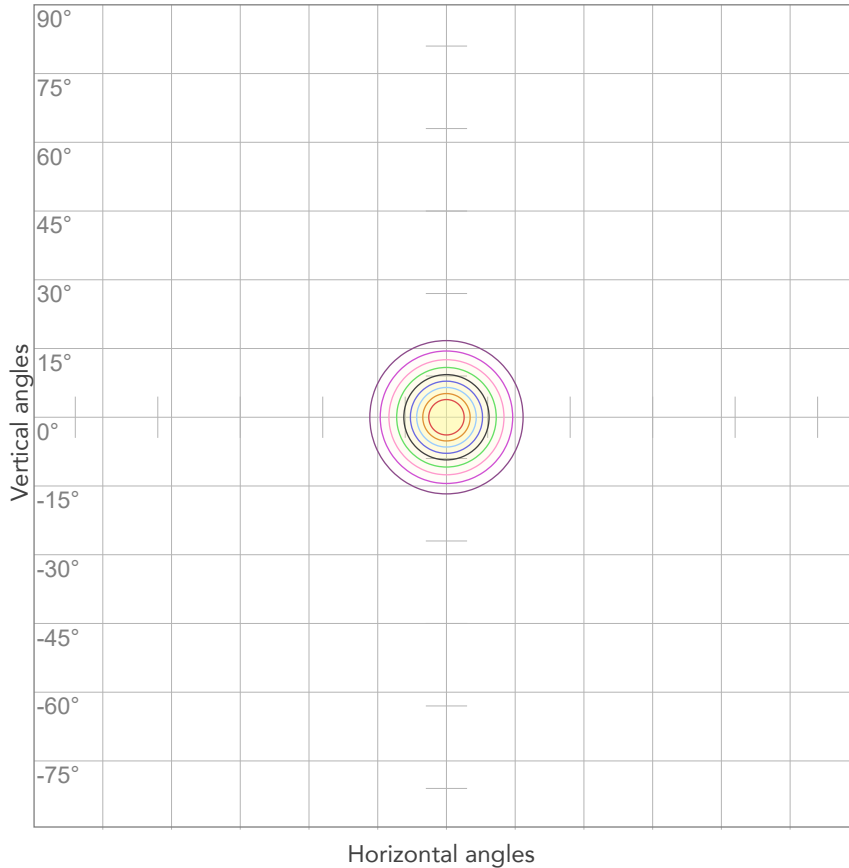

10%	2372 cd
20%	4745 cd
30%	7117 cd
40%	9489 cd
50%	11861 cd
60%	14234 cd
70%	16606 cd
80%	18978 cd

Conditions:

Number of c-planes: 2

Candela at center: 23723 cd

## ISO LUX DIAGRAM

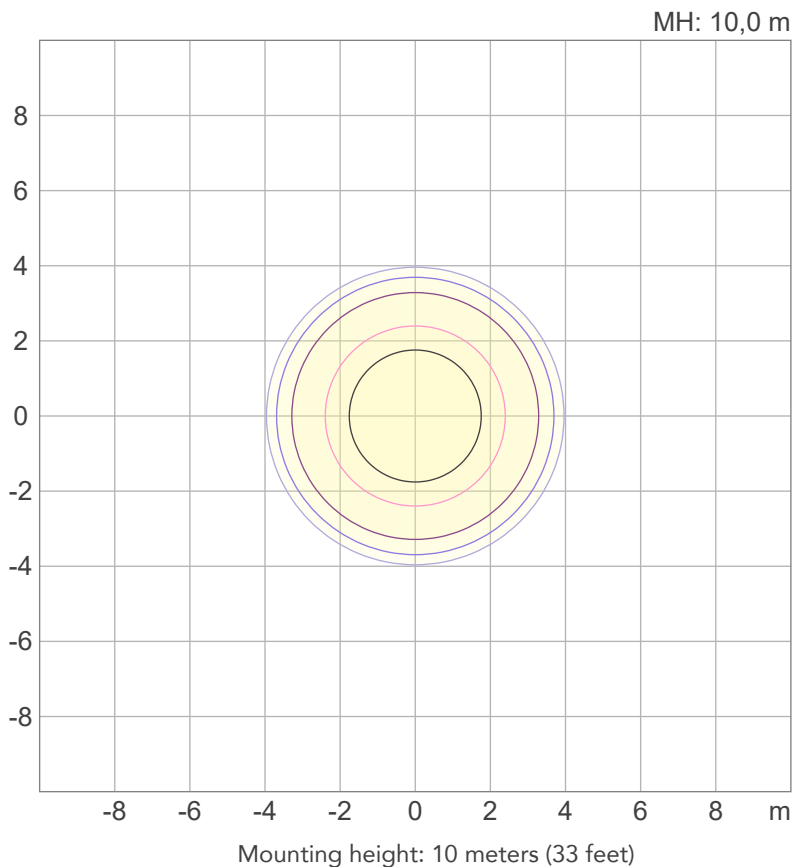

3%	7,12 lx
5%	11,9 lx
10%	23,7 lx
30%	71,2 lx
50%	119 lx

Conditions:

Number of c-planes: 2

Lux at center: 237 lx

*Lux distribution on a surface when lamp is mounted at 10 meters from the surface.*



Total lumen output:

1922 lm

Peak candela output:

56756 cd

Light quality:

CRI: 95,5

Color temperature:

4025 K

**PRODUCT NAME:**

ECLFRCTPS

**MEASURAMENT CONDITIONS:**

Beam angle:

Min Zoom

Target:

4000K - HB

Operator:

Salvatore Giglio

Date and time:

02/10/2023 16:22:00

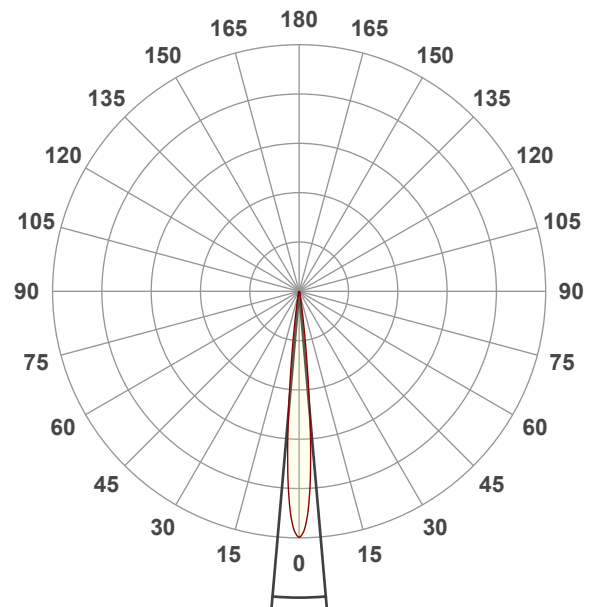

Beam angle 50%: 10°

Field angle 10%: 16,9°

Cut off angle 2.5%: 23,1°

Spectra

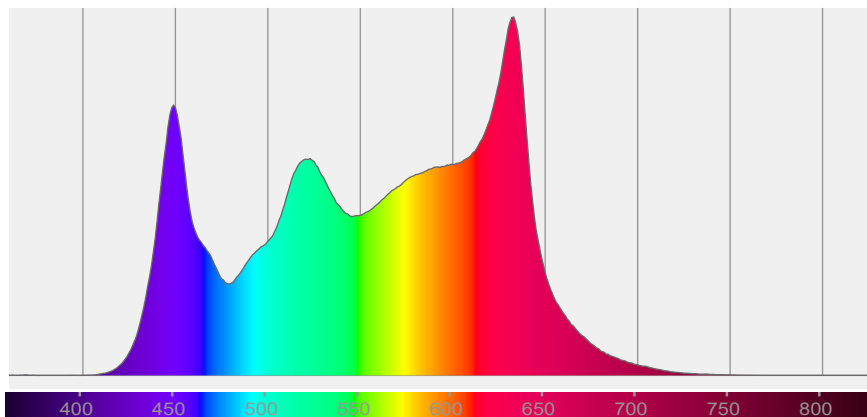

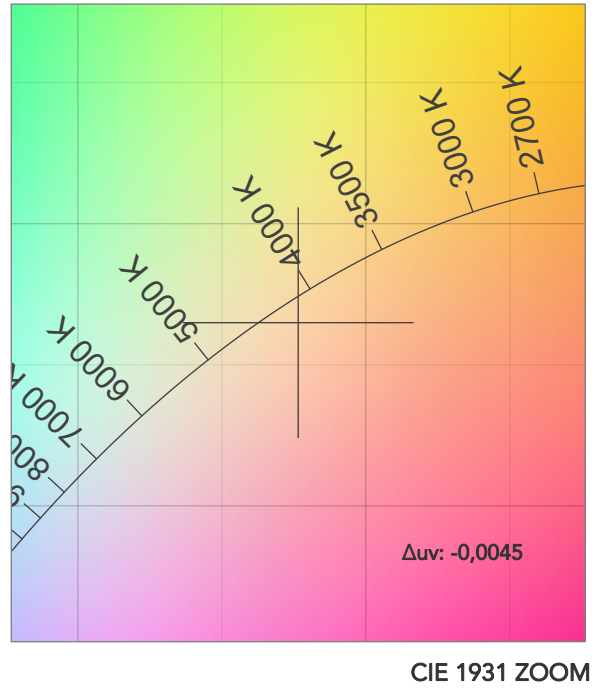
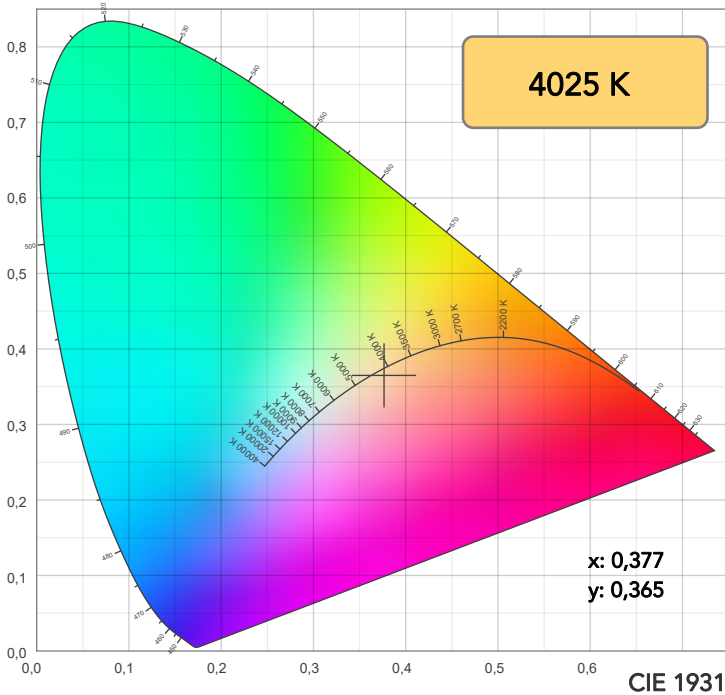

TM30: 93,7

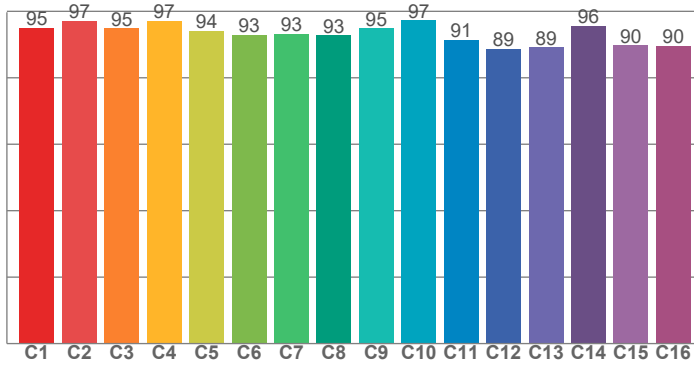

CRI: 95,5 (R1-R8)

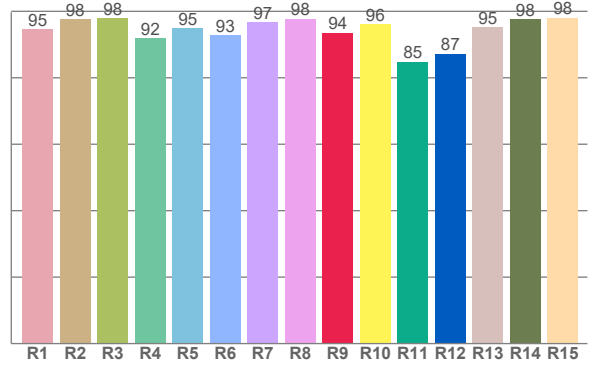

CRI R values, only R1-R8 are used to calculate final CRI value

R1	R2	R3	R4	R5	R6	R7	R8	R9	R10	R11	R12	R13	R14	R15
94,6	97,7	98,0	91,9	94,8	92,8	96,7	97,7	93,6	96,0	84,8	87,2	95,2	97,7	98,1

TM30 C values, 16 binned values out of total of 99 C values

C1	C2	C3	C4	C5	C6	C7	C8	C9	C10	C11	C12	C13	C14	C15	C16
95,0	97,1	94,9	97,1	94,1	92,9	93,1	92,8	94,9	97,2	91,4	88,8	89,2	95,6	89,7	89,6

CQS Q values

Q1	Q2	Q3	Q4	Q5	Q6	Q7	Q8	Q9	Q10	Q11	Q12	Q13	Q14	Q15
95,2	98,1	92,4	97,8	96,7	93,9	96,9	99,7	98,6	98,0	99,1	99,6	98,7	96,1	96,0

CQS: 96,5

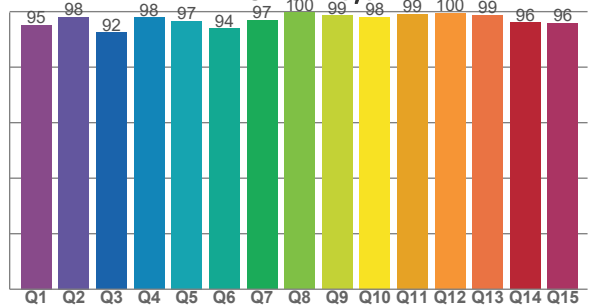

COLOR PARAMETERS

Color temperature	Color rendering index	Red component	Color fidelity	Color gamut	Color quality scale	Television lighting index	Color coordinate cie 1931	Color coordinate cie 1931	Color deviation from black body
CCT	CRI	CRI R9	TM30 Rf	TM30 Rg	CQS	TLCI	x	y	Δuv
4025 K	95,5	93,6	93,7	103,5	96,5	87	0,377	0,365	-0,0045

# TM30 DETAILS

**Rf 93,7**  
Fidelity index Rf

**Rg 103,5**  
Gammut index

Hue Bin	R <sub>f</sub>	Graphic shifts (%)	
		Chroma	Hue
1	95	-1%	0%
2	97	1%	0%
3	95	1%	2%
4	97	0%	0%
5	94	-1%	1%
6	93	4%	3%
7	93	4%	2%
8	93	3%	1%
9	95	3%	2%
10	97	0%	1%
11	91	4%	3%
12	89	4%	0%
13	89	4%	-7%
14	96	3%	1%
15	90	2%	-6%
16	90	1%	-6%

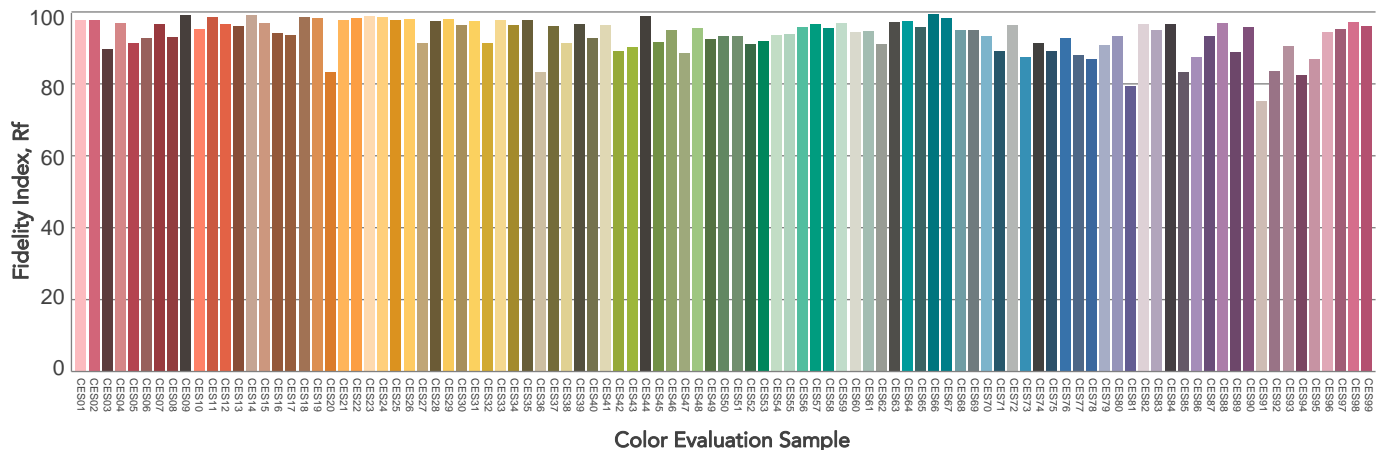
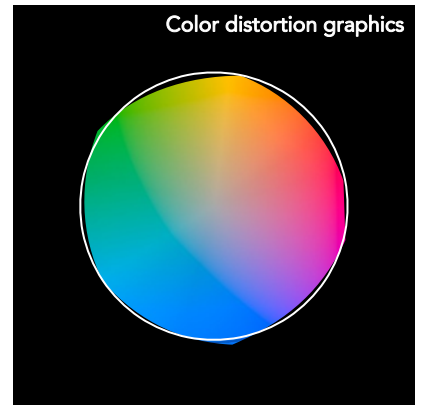
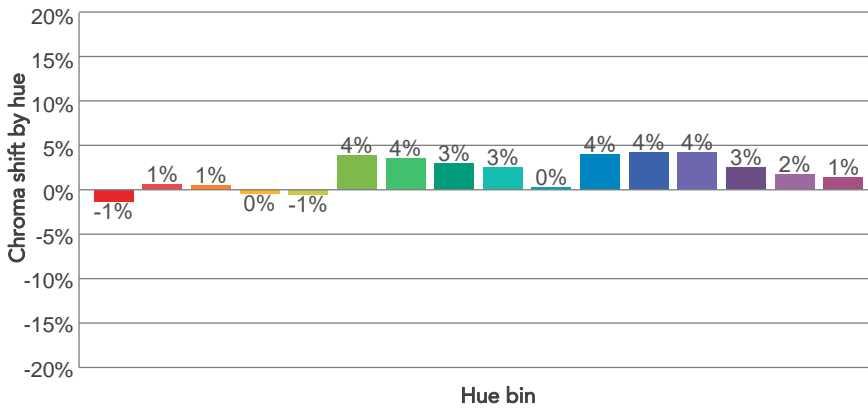
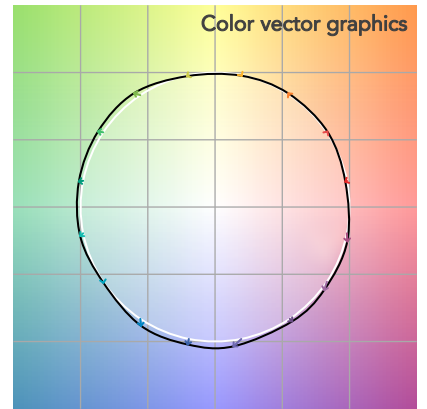
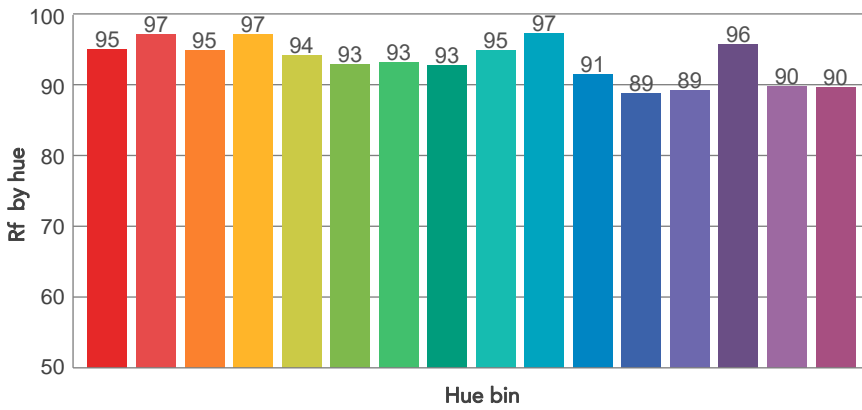
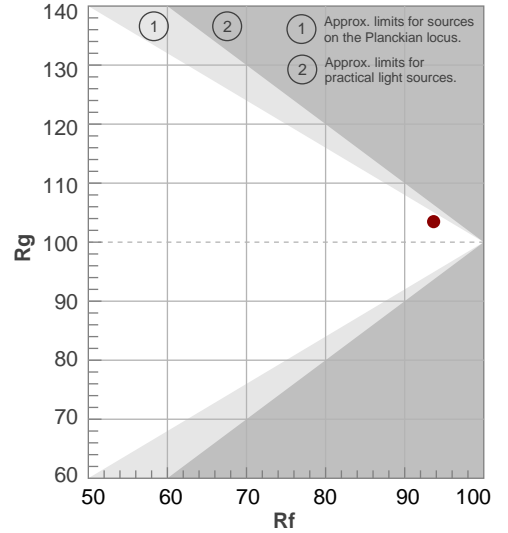

# BEAM DETAILS



Beam angle 50%	Field angle 10%	Cut off angle 2,5%	Intensity ratio in 120° cone	Intensity ratio in 90° cone
10°	16,9°	23,1°	100,0%	100,0%

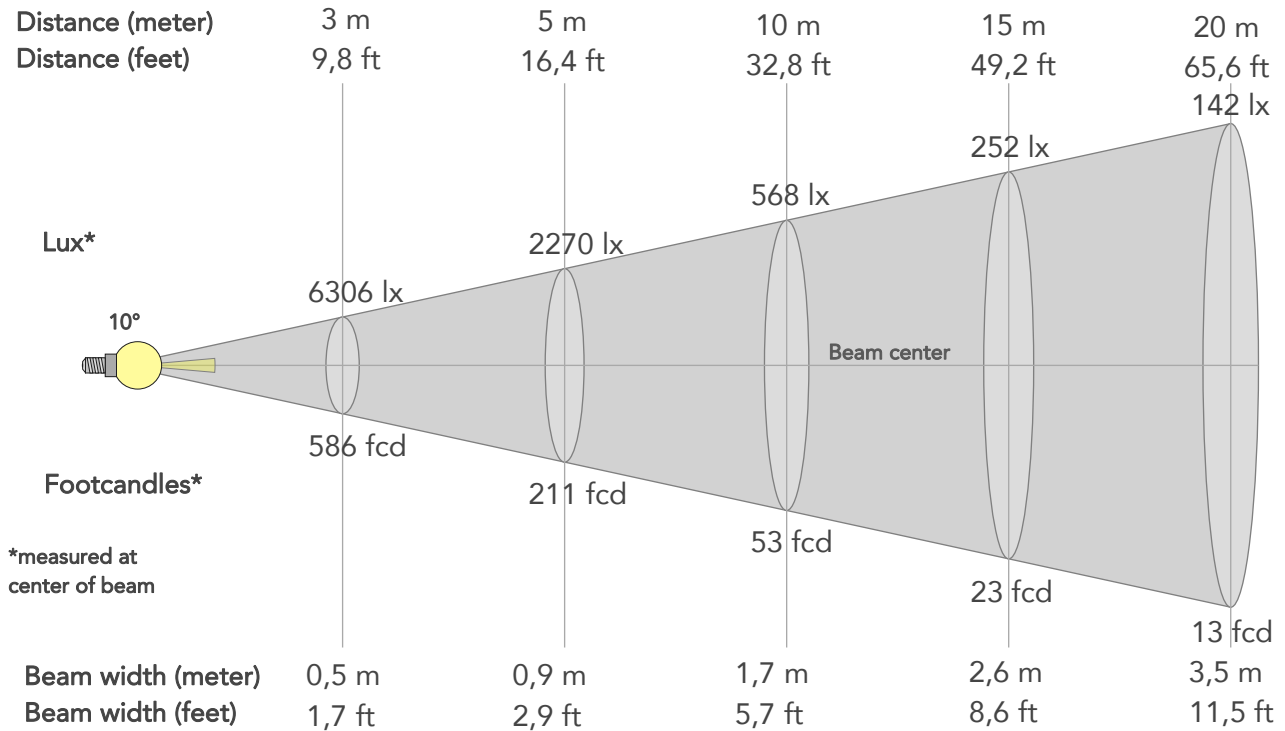

## BEAM INTENSITIES AND WIDTHS

Distance	1m	2m	3m	4m	5m	7,5m	10m	15m	20m	25m	30m	40m	50m
Distance	3,3ft	6,6ft	9,8ft	13,1ft	16,4ft	24,6ft	32,8ft	49,2ft	65,6ft	82ft	98,4ft	131,2ft	164ft
Lux	56756lx	14189lx	6306lx	3547lx	2270lx	1009lx	568lx	252lx	142lx	91lx	63lx	35lx	23lx
Footcand.	5273fcd	1318fcd	586fcd	330fcd	211fcd	94fcd	53fcd	23fcd	13fcd	8fcd	6fcd	3fcd	2fcd
Beam wid.	0,2m	0,3m	0,5m	0,7m	0,9m	1,3m	1,7m	2,6m	3,5m	4,4m	5,2m	7m	8,7m
Beam wid.	0,6ft	1,2ft	1,7ft	2,3ft	2,9ft	4,3ft	5,7ft	8,6ft	11,5ft	14,3ft	17,2ft	22,9ft	28,7ft

## LINEAR DISTRIBUTION DIAGRAM

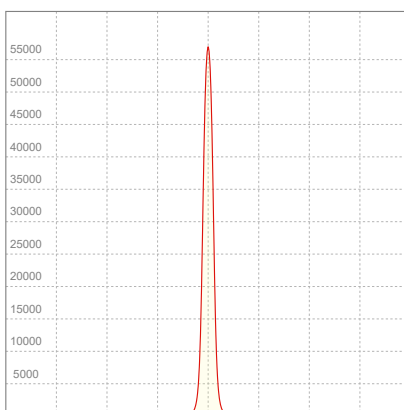

## ELECTRICAL SPECIFICATIONS

Input voltage	Input current	Input power	Effeciency
226V	0,872A	195,9W	10lm/W

## ISO CANDELA DIAGRAM

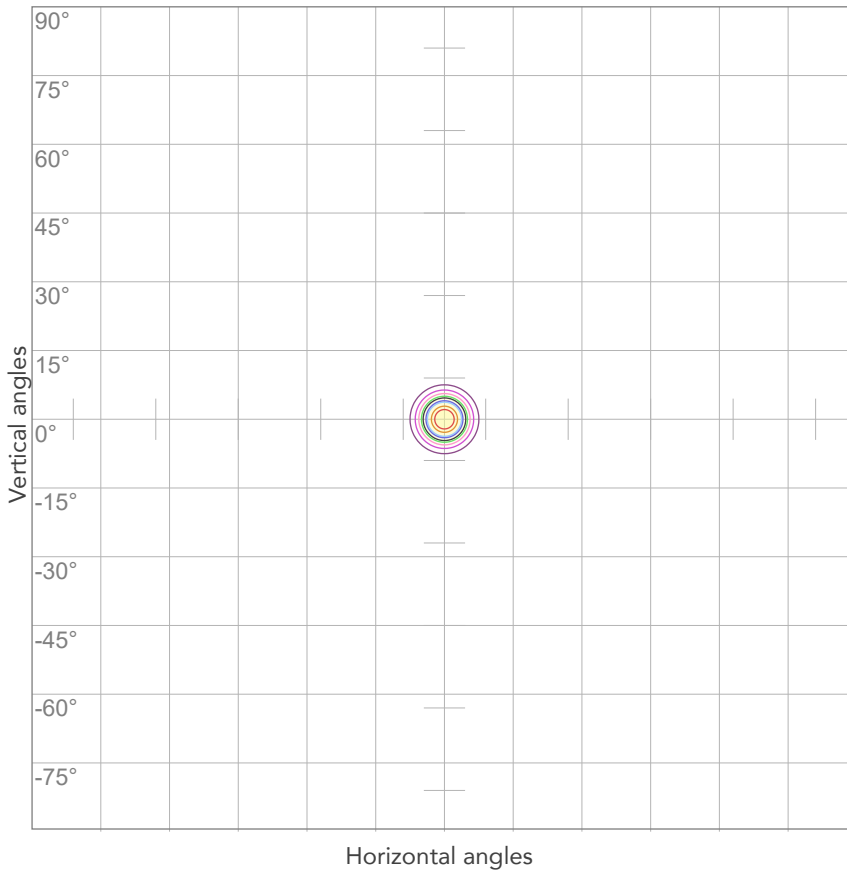

10%	5676 cd
20%	11351 cd
30%	17027 cd
40%	22702 cd
50%	28378 cd
60%	34053 cd
70%	39729 cd
80%	45405 cd

Conditions:

Number of c-planes: 2

Candela at center: 56756 cd

## ISO LUX DIAGRAM

MH: 10,0 m

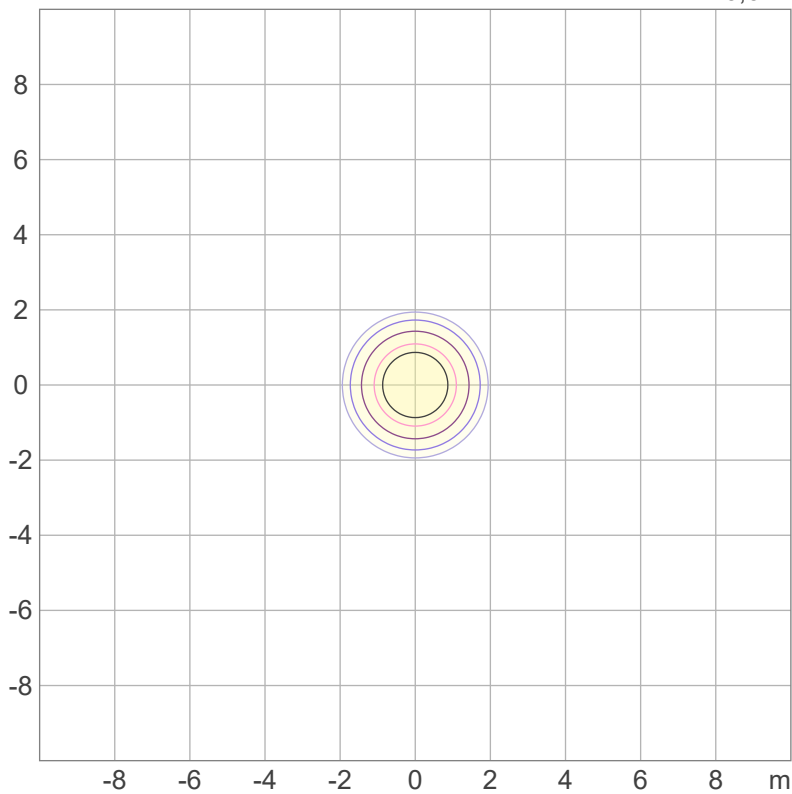

3%	17,0 lx
5%	28,4 lx
10%	56,8 lx
30%	170 lx
50%	284 lx

Conditions:

Number of c-planes: 2

Lux at center: 568 lx

*Lux distribution on a surface when lamp is mounted at 10 meters from the surface.*





Total lumen output:

4857 lm

Peak candela output:

7250 cd

Light quality:

CRI: 92,6

Color temperature:

5405 K

PRODUCT NAME:

ECLFRCTPS

MEASURAMENT CONDITIONS:

Beam angle:

Max Zoom

Target:

5600K - HB

Operator:

Salvatore Giglio

Date and time:

02/10/2023 15:13:14

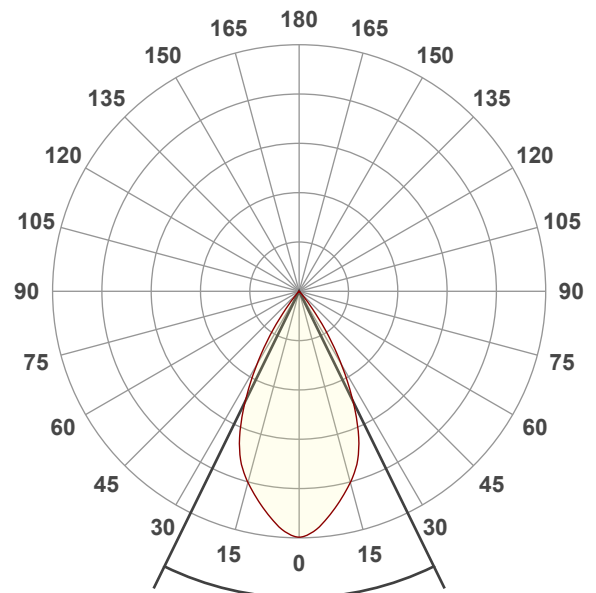

Beam angle 50%: 52,2°

Field angle 10%: 73,7°

Cut off angle 2.5%: 81,8°

Spectra

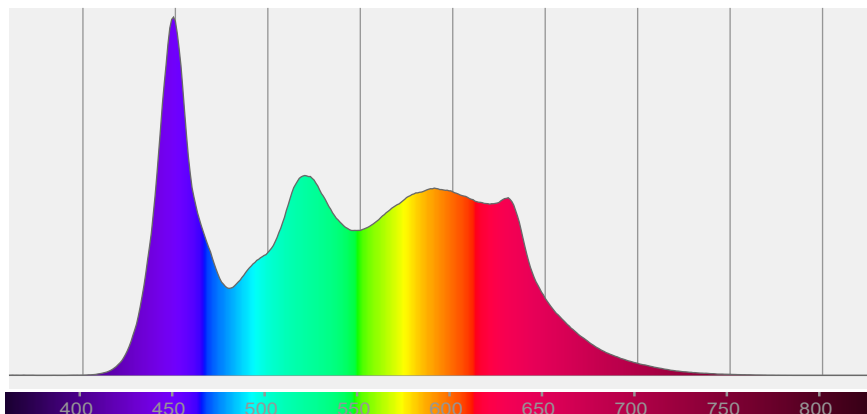

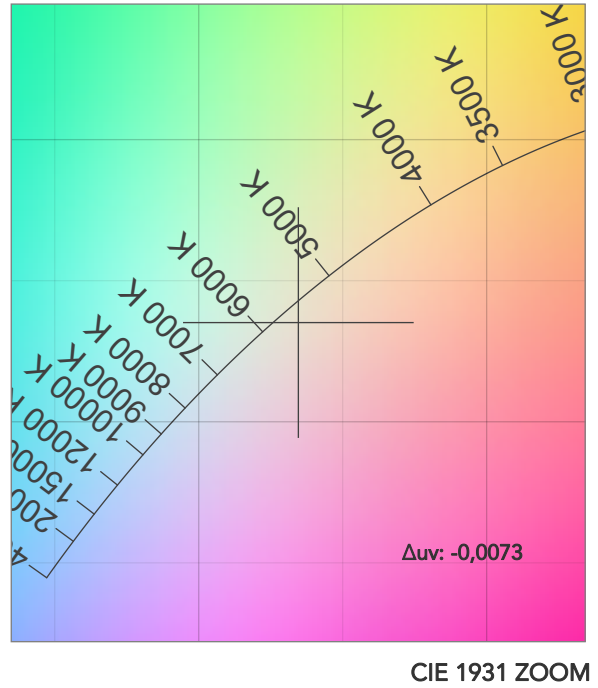
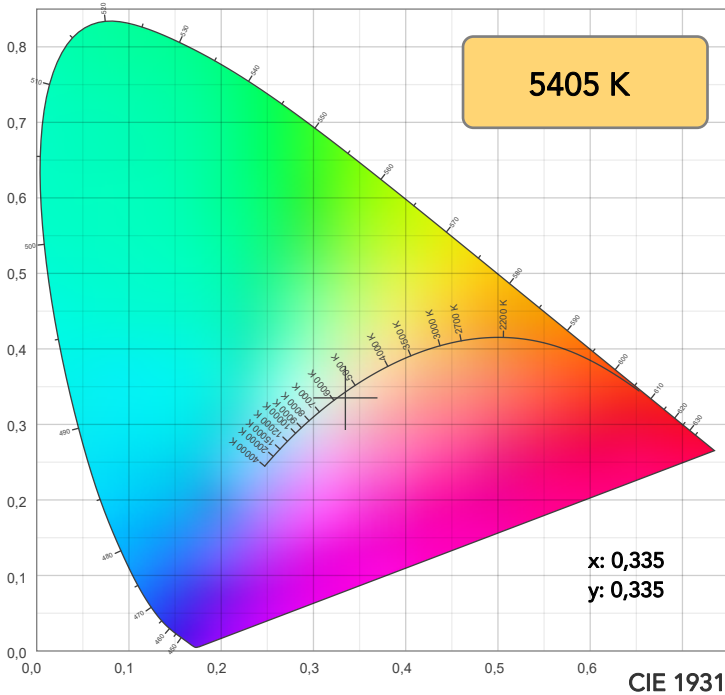

TM30: 89,4

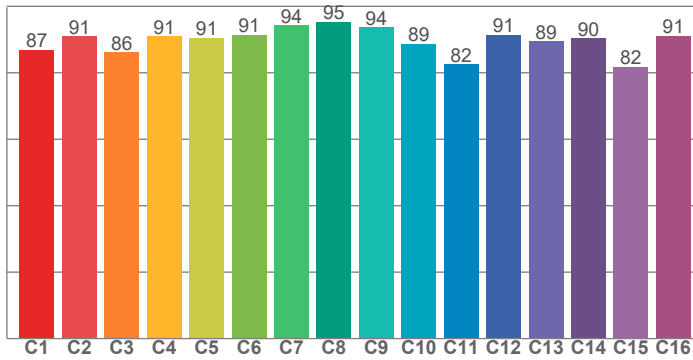

CRI: 92,6 (R1-R8)

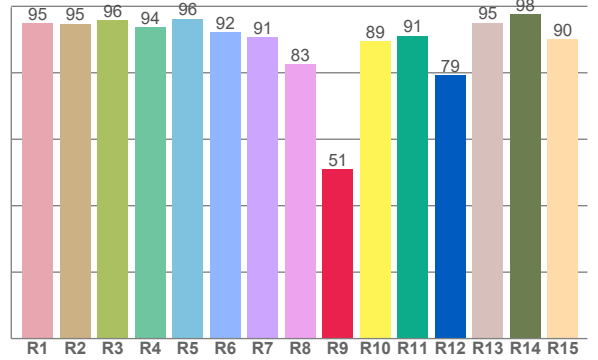

CQS: 89,1

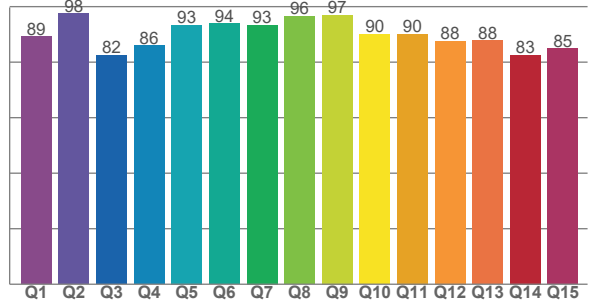

CRI R values, only R1-R8 are used to calculate final CRI value

R1	R2	R3	R4	R5	R6	R7	R8	R9	R10	R11	R12	R13	R14	R15
95,0	94,8	95,8	93,7	96,3	92,1	90,7	82,6	50,9	89,4	91,1	79,2	95,1	97,7	90,2

TM30 C values, 16 binned values out of total of 99 C values

C1	C2	C3	C4	C5	C6	C7	C8	C9	C10	C11	C12	C13	C14	C15	C16
86,8	91,0	86,1	91,0	90,6	91,5	94,3	95,3	93,7	88,7	82,5	91,3	89,5	90,4	81,7	91,2

CQS Q values

Q1	Q2	Q3	Q4	Q5	Q6	Q7	Q8	Q9	Q10	Q11	Q12	Q13	Q14	Q15
89,2	97,6	82,5	86,0	93,4	93,9	93,5	96,5	96,9	90,0	90,1	87,7	87,8	82,6	85,0

COLOR PARAMETERS

Color temperature	Color rendering index	Red component	Color fidelity	Color gamut	Color quality scale	Television lighting index	Color coordinate cie 1931	Color coordinate cie 1931	Color deviation from black body
CCT	CRI	CRI R9	TM30 Rf	TM30 Rg	CQS	TLCI	x	y	Δuv
5405 K	92,6	50,9	89,4	101,8	89,1	83	0,335	0,335	-0,0073

# TM30 DETAILS

**Rf 89,4**  
Fidelity index Rf

**Rg 101,8**  
Gammut index

Hue Bin	R <sub>f</sub>	Graphic shifts (%)	
		Chroma	Hue
1	87	-7%	-1%
2	91	-3%	5%
3	86	-1%	8%
4	91	1%	5%
5	91	2%	4%
6	91	6%	2%
7	94	3%	-1%
8	95	0%	0%
9	94	-2%	3%
10	89	-2%	6%
11	82	2%	10%
12	91	4%	3%
13	89	7%	-4%
14	90	5%	-3%
15	82	5%	-16%
16	91	-1%	-5%

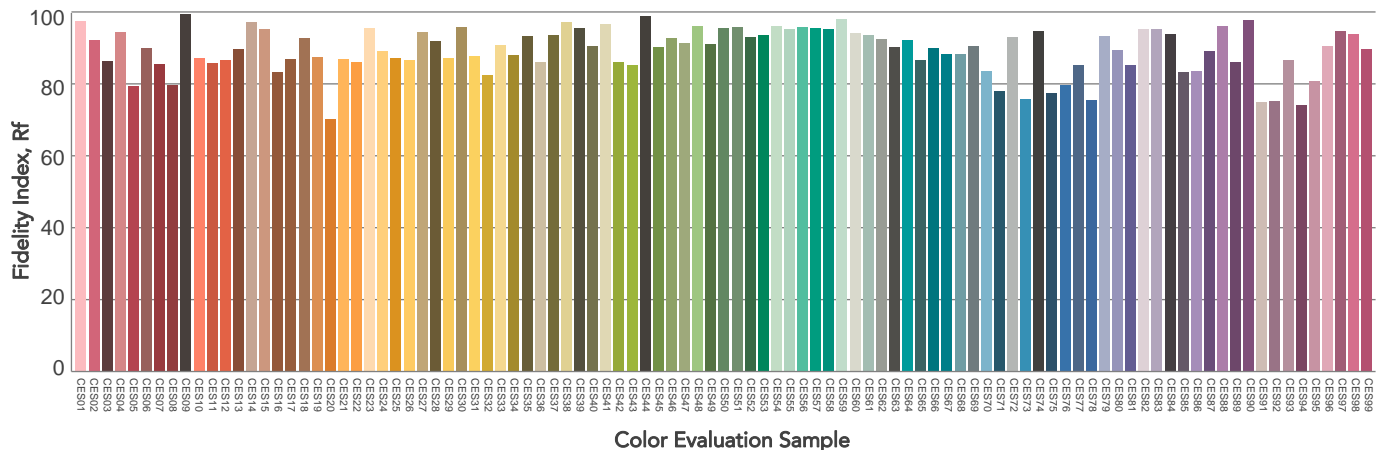
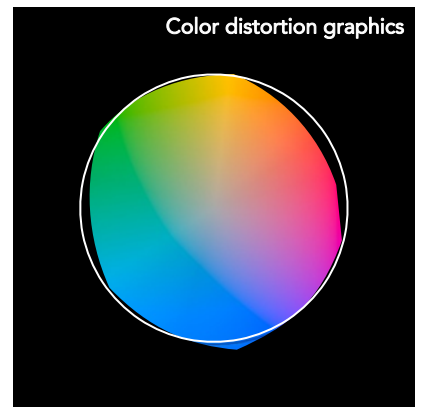
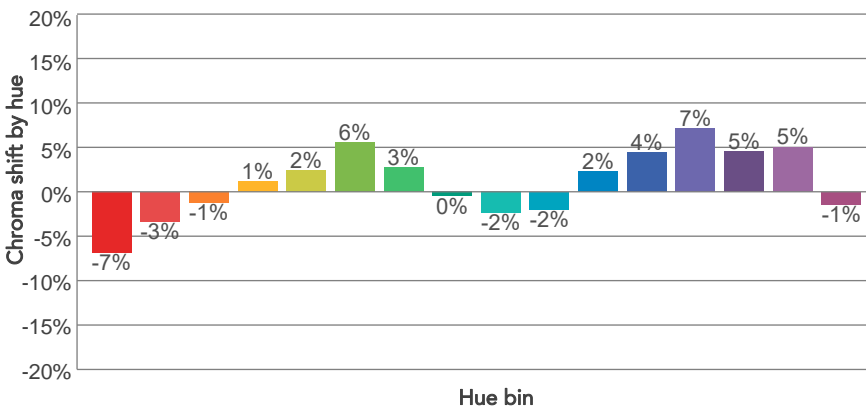
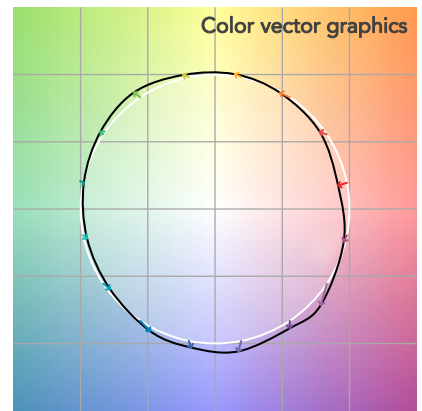
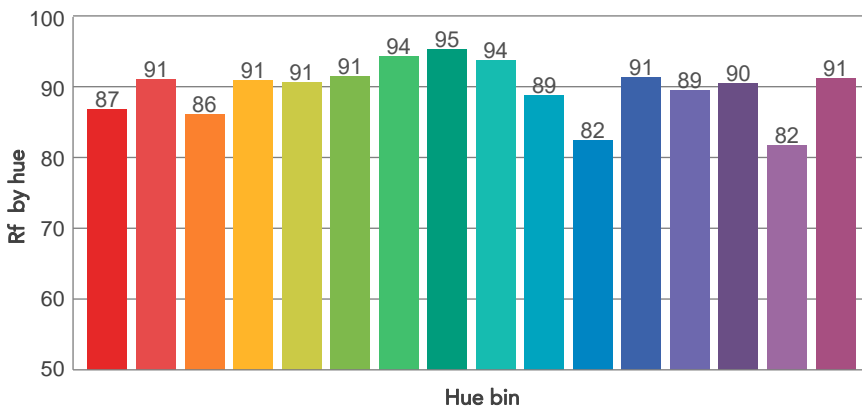
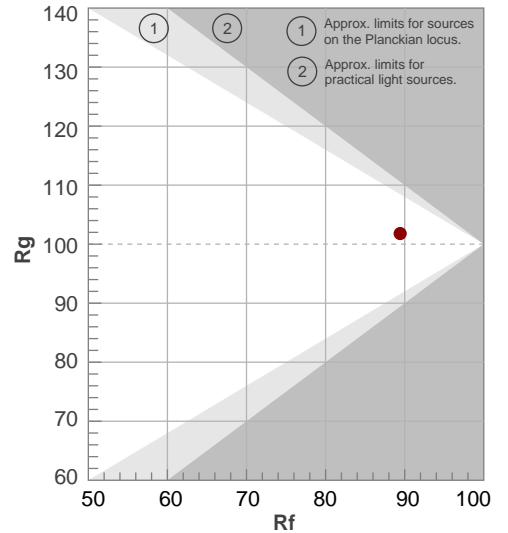

# BEAM DETAILS



Beam angle 50%	Field angle 10%	Cut off angle 2,5%	Intensity ratio in 120° cone	Intensity ratio in 90° cone
52,2°	73,7°	81,8°	100,0%	99,4%

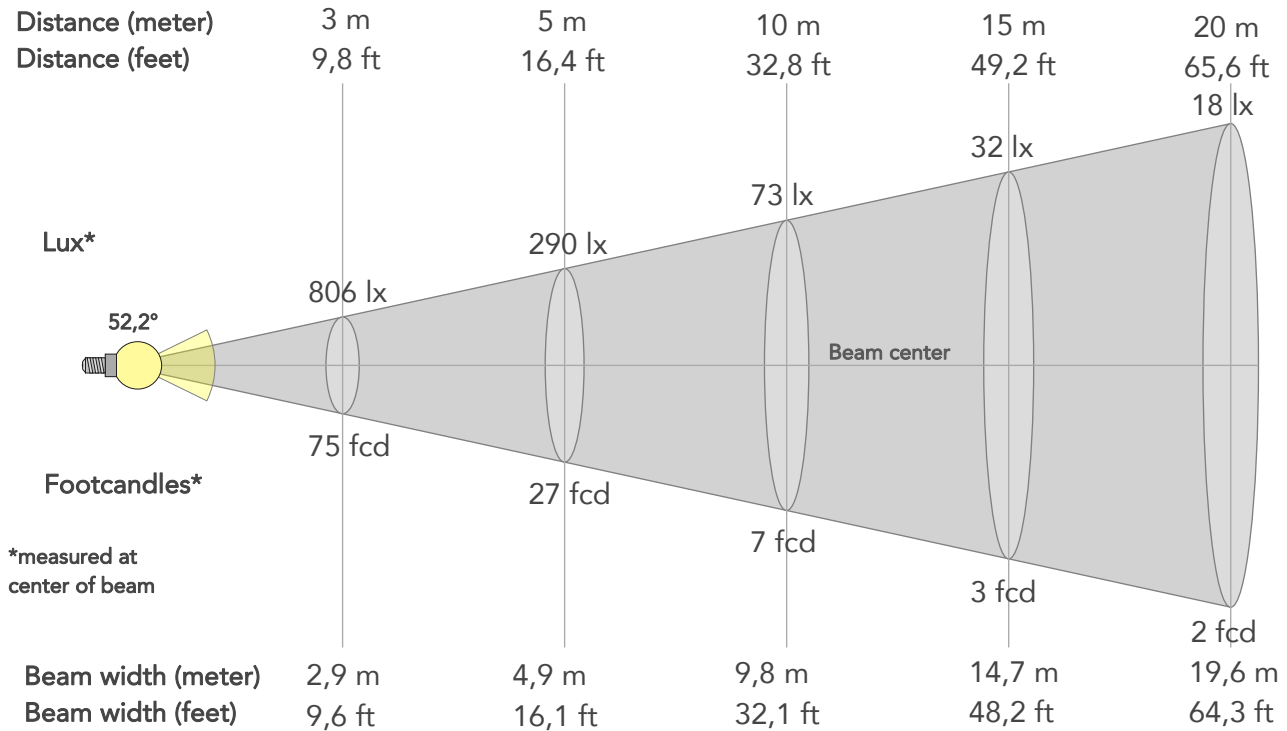

## BEAM INTENSITIES AND WIDTHS

Distance	1m	2m	3m	4m	5m	7,5m	10m	15m	20m	25m	30m	40m	50m
Distance	3,3ft	6,6ft	9,8ft	13,1ft	16,4ft	24,6ft	32,8ft	49,2ft	65,6ft	82ft	98,4ft	131,2ft	164ft
Lux	7250lx	1813lx	806lx	453lx	290lx	129lx	73lx	32lx	18lx	12lx	8lx	5lx	3lx
Footcand.	674fcd	168fcd	75fcd	42fcd	27fcd	12fcd	7fcd	3fcd	2fcd	1fcd	1fcd	0fcd	0fcd
Beam wid.	1m	2m	2,9m	3,9m	4,9m	7,3m	9,8m	14,7m	19,6m	24,5m	29,4m	39,2m	49m
Beam wid.	3,2ft	6,5ft	9,6ft	12,8ft	16,1ft	24,1ft	32,1ft	48,2ft	64,3ft	80,3ft	96,4ft	128,5ft	160,6ft

## LINEAR DISTRIBUTION DIAGRAM

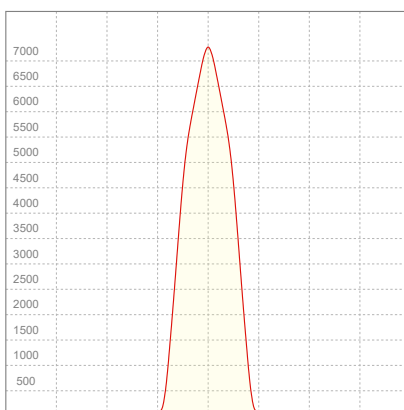

## ELECTRICAL SPECIFICATIONS

Input voltage	Input current	Input power	Effeciency
226V	0,883A	198,3W	24lm/W

## ISO CANDELA DIAGRAM

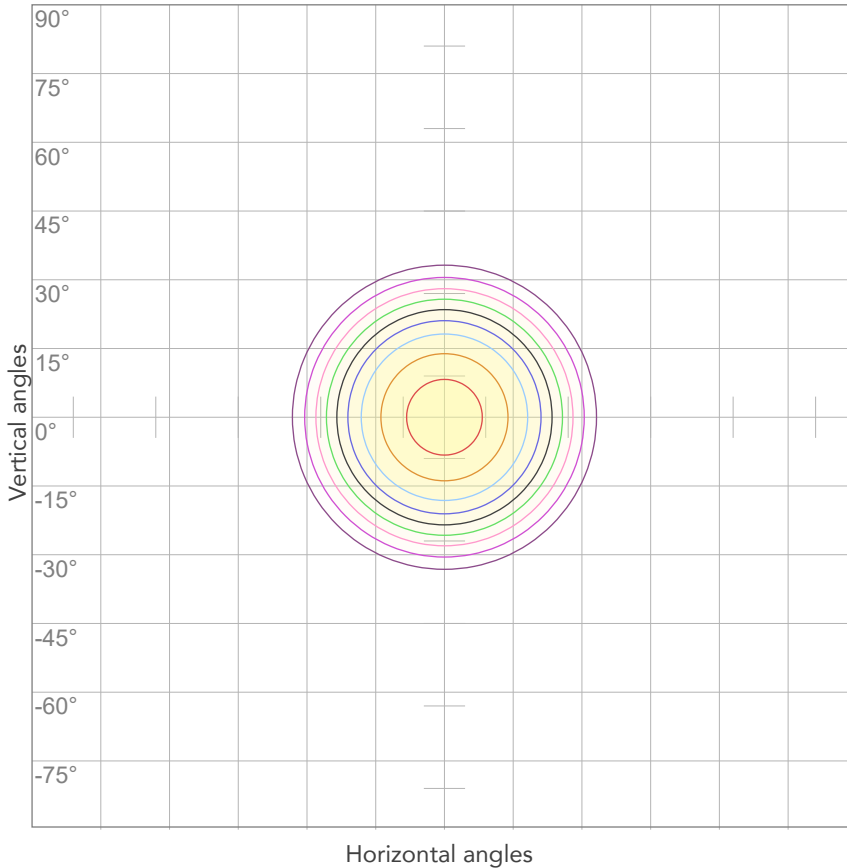

10%	725 cd
20%	1450 cd
30%	2175 cd
40%	2900 cd
50%	3625 cd
60%	4350 cd
70%	5075 cd
80%	5800 cd

Conditions:

Number of c-planes: 2

Candela at center: 7250 cd

## ISO LUX DIAGRAM

MH: 10,0 m

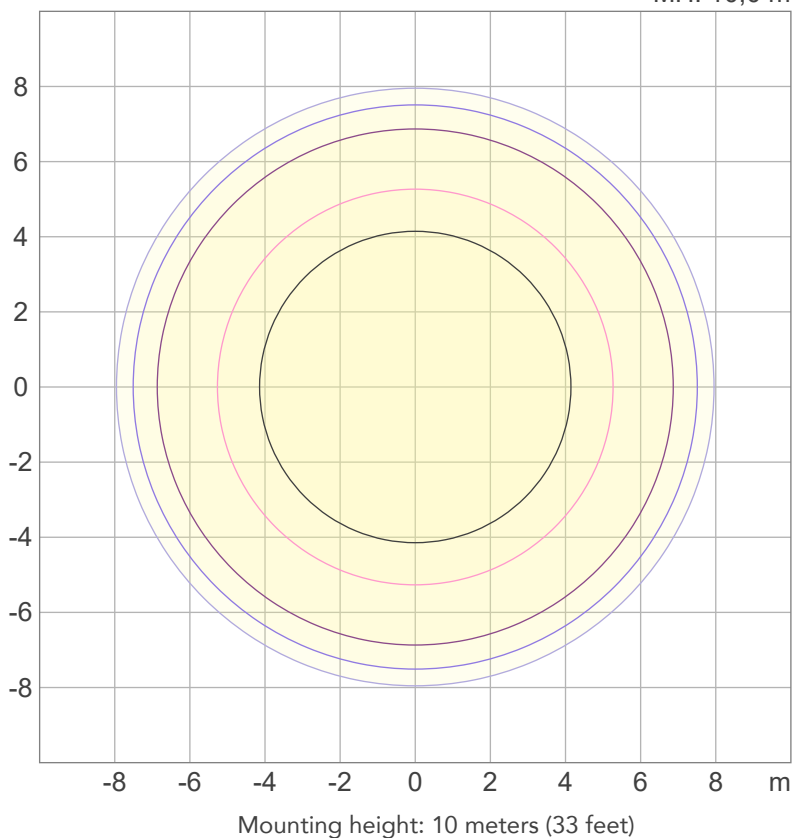

3%	2,18 lx
5%	3,63 lx
10%	7,25 lx
30%	21,8 lx
50%	36,3 lx

Conditions:

Number of c-planes: 2

Lux at center: 72,5 lx

*Lux distribution on a surface when lamp is mounted at 10 meters from the surface.*



Total lumen output:

3563 lm

Peak candela output:

23842 cd

Light quality:

CRI: 92,2

Color temperature:

5573 K

**PRODUCT NAME:**

ECLFRCTPS

**MEASURAMENT CONDITIONS:**

Beam angle:

Med Zoom

Target:

5600K - HB

Operator:

Salvatore Giglio

Date and time:

02/10/2023 17:06:39

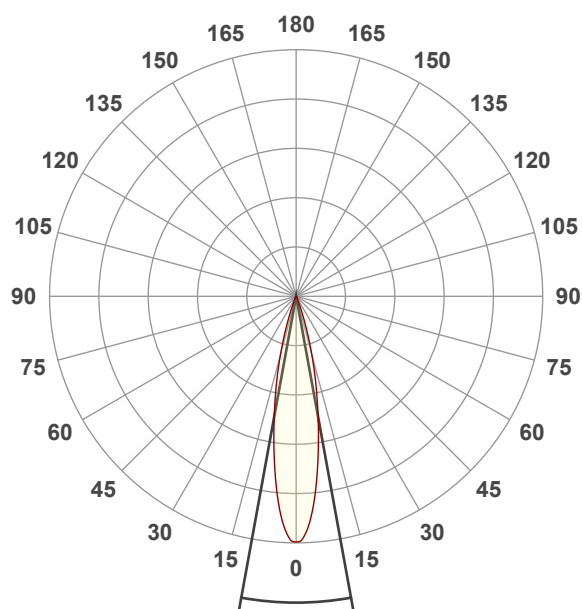

Beam angle 50%: 20,6°

Field angle 10%: 37,3°

Cut off angle 2.5%: 46°

Spectra

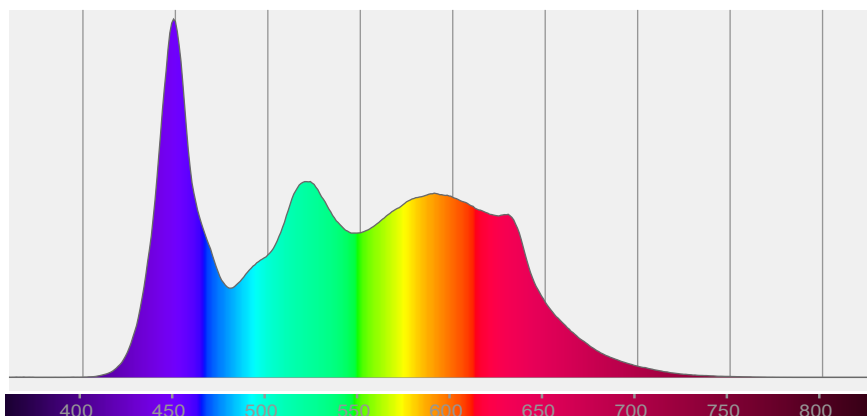

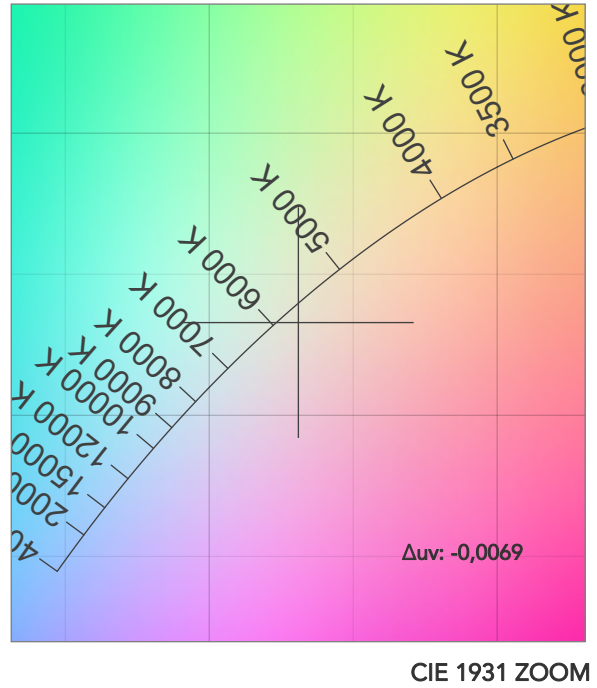
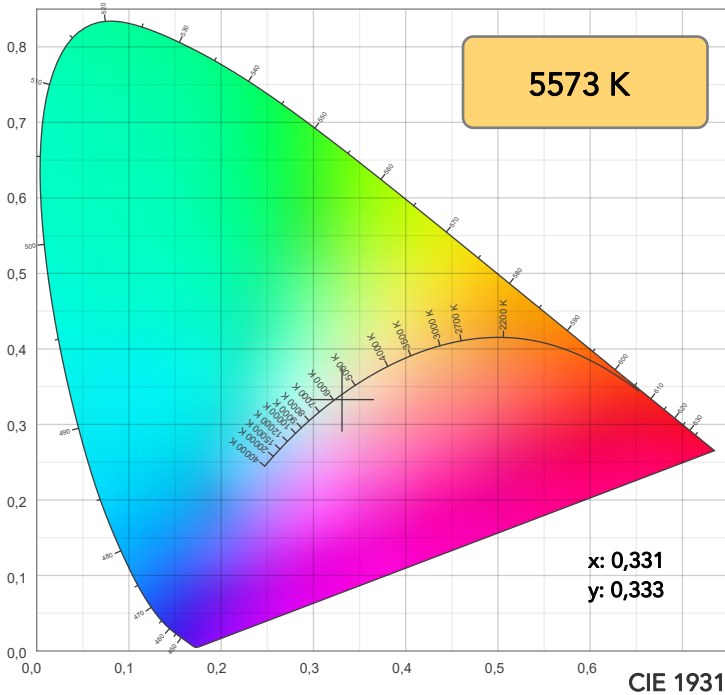

TM30: 89,2

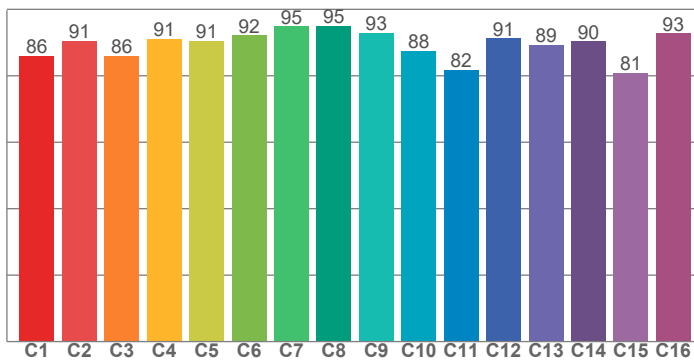

CRI: 92,2 (R1-R8)

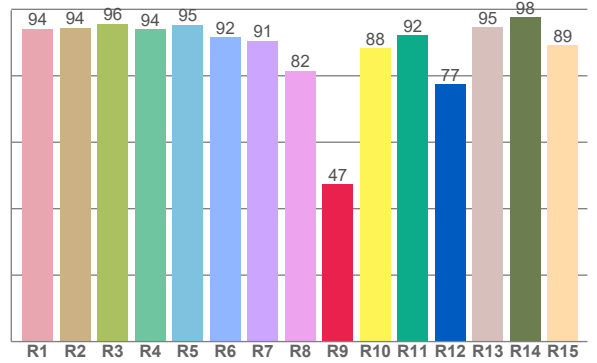

CQS: 88,5

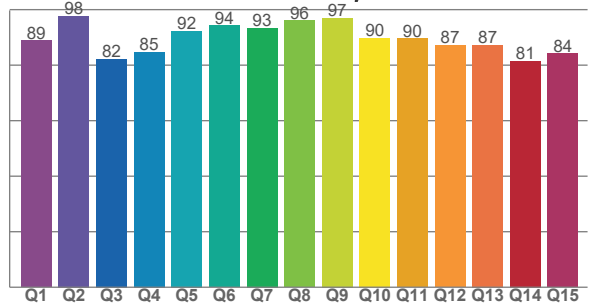

CRI R values, only R1-R8 are used to calculate final CRI value

R1	R2	R3	R4	R5	R6	R7	R8	R9	R10	R11	R12	R13	R14	R15
94,2	94,5	95,6	94,0	95,4	91,7	90,6	81,5	47,3	88,4	92,3	77,4	94,6	97,7	89,2

TM30 C values, 16 binned values out of total of 99 C values

C1	C2	C3	C4	C5	C6	C7	C8	C9	C10	C11	C12	C13	C14	C15	C16
85,9	90,5	85,9	91,0	90,6	92,2	94,8	95,1	93,0	87,5	81,8	91,3	89,4	90,3	80,8	92,8

CQS Q values

Q1	Q2	Q3	Q4	Q5	Q6	Q7	Q8	Q9	Q10	Q11	Q12	Q13	Q14	Q15
88,8	97,7	82,1	84,8	92,3	94,2	93,4	96,1	97,0	89,8	89,5	87,2	87,2	81,5	84,1

COLOR PARAMETERS

Color temperature	Color rendering index	Red component	Color fidelity	Color gamut	Color quality scale	Television lighting index	Color coordinate cie 1931	Color coordinate cie 1931	Color deviation from black body
CCT	CRI	CRI R9	TM30 Rf	TM30 Rg	CQS	TLCI	x	y	Δuv
5573 K	92,2	47,3	89,2	101,1	88,5	83	0,331	0,333	-0,0069

# TM30 DETAILS

**Rf 89,2**  
Fidelity index Rf

**Rg 101,1**  
Gammut index

Hue Bin	R <sub>f</sub>	Graphic shifts (%)	
		Chroma	Hue
1	86	-7%	-1%
2	91	-4%	5%
3	86	-2%	8%
4	91	1%	5%
5	91	2%	4%
6	92	5%	2%
7	95	2%	0%
8	95	-1%	0%
9	93	-3%	4%
10	88	-2%	7%
11	82	2%	11%
12	91	5%	3%
13	89	7%	-4%
14	90	4%	-3%
15	81	5%	-16%
16	93	-2%	-3%

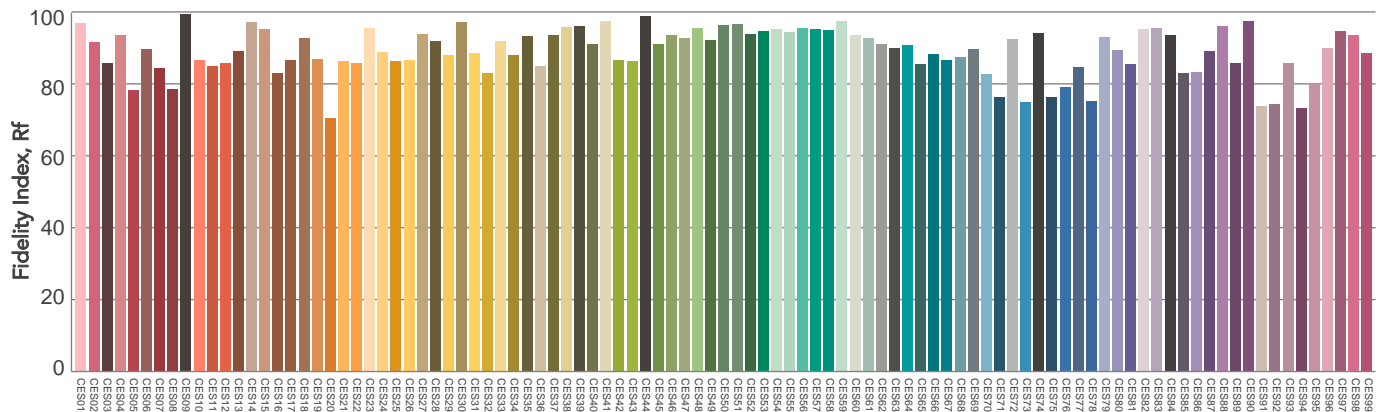
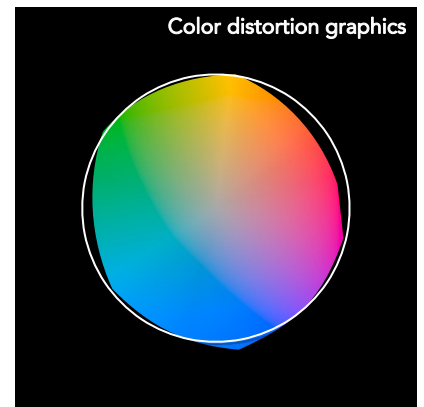
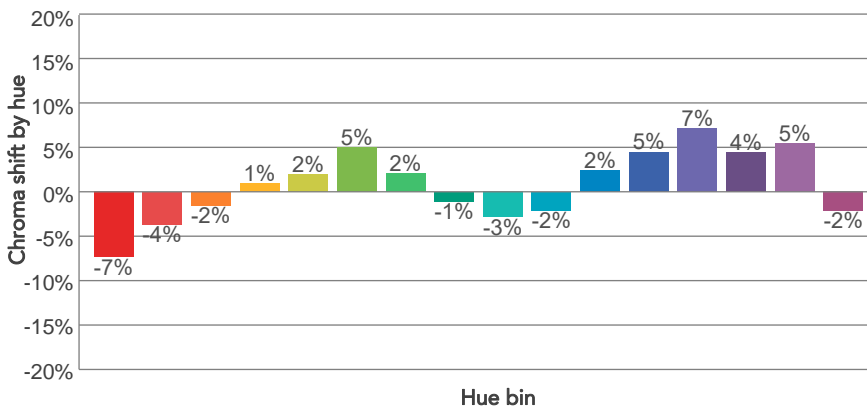
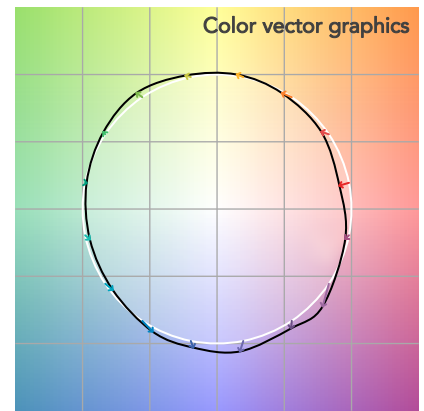
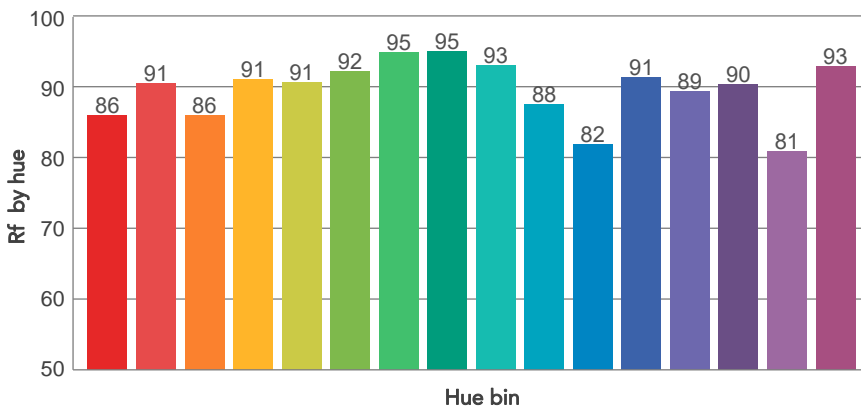
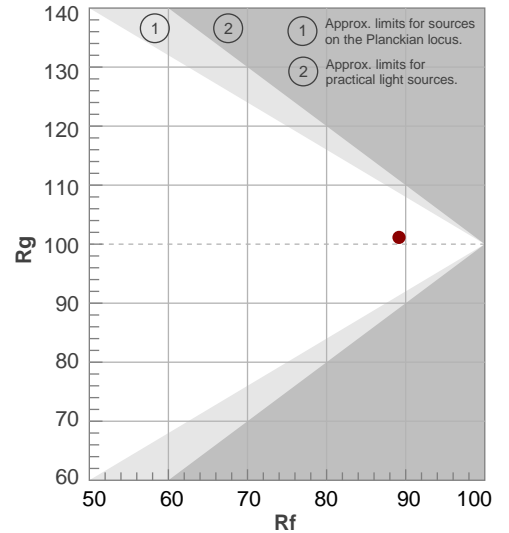



# BEAM DETAILS



Beam angle 50%	Field angle 10%	Cut off angle 2,5%	Intensity ratio in 120° cone	Intensity ratio in 90° cone
20,6°	37,3°	46°	100,0%	99,9%

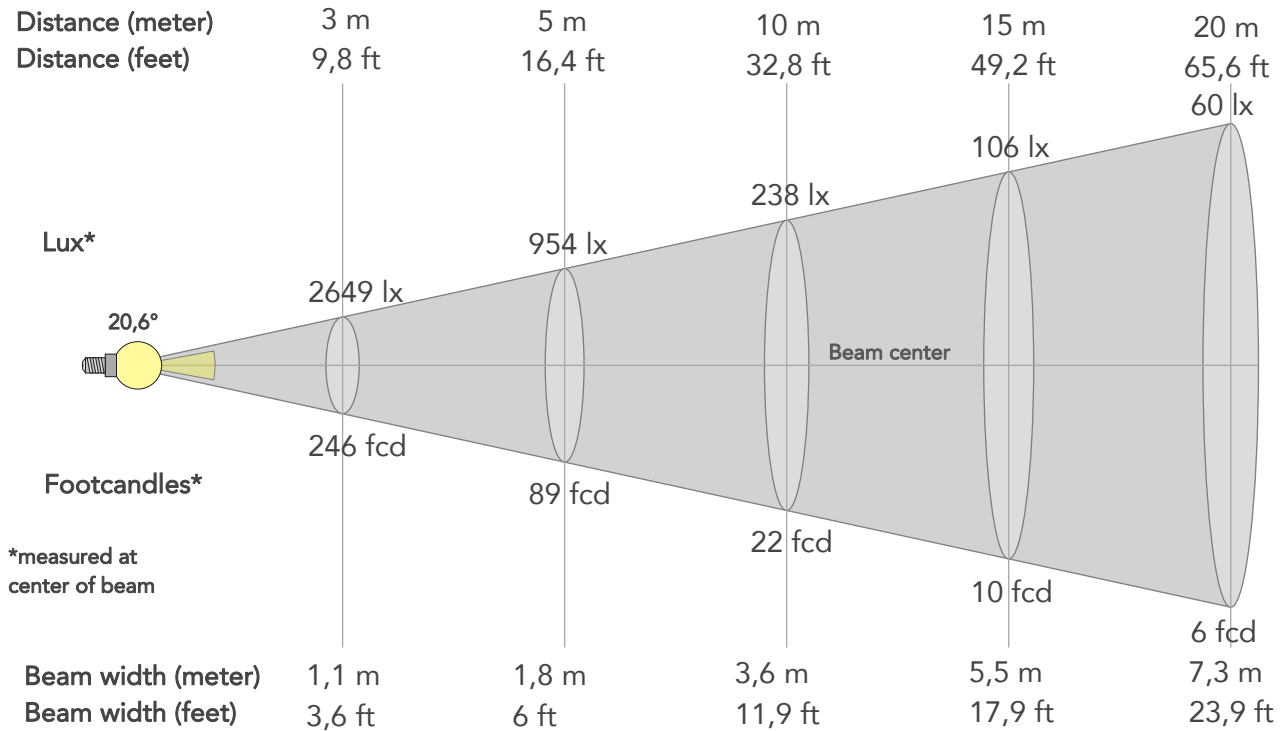

## BEAM INTENSITIES AND WIDTHS

Distance	1m	2m	3m	4m	5m	7,5m	10m	15m	20m	25m	30m	40m	50m
Distance	3,3ft	6,6ft	9,8ft	13,1ft	16,4ft	24,6ft	32,8ft	49,2ft	65,6ft	82ft	98,4ft	131,2ft	164ft
Lux	23842lx	5960lx	2649lx	1490lx	954lx	424lx	238lx	106lx	60lx	38lx	26lx	15lx	10lx
Footcand.	2215fcd	554fcd	246fcd	138fcd	89fcd	39fcd	22fcd	10fcd	6fcd	4fcd	2fcd	1fcd	1fcd
Beam wid.	0,4m	0,7m	1,1m	1,5m	1,8m	2,7m	3,6m	5,5m	7,3m	9,1m	10,9m	14,6m	18,2m
Beam wid.	1,2ft	2,4ft	3,6ft	4,8ft	6ft	9ft	11,9ft	17,9ft	23,9ft	29,9ft	35,8ft	47,8ft	59,7ft

## LINEAR DISTRIBUTION DIAGRAM

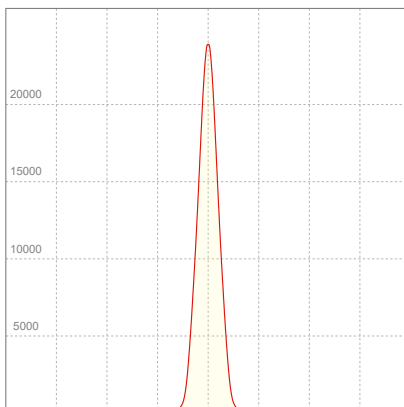

## ELECTRICAL SPECIFICATIONS

Input voltage	Input current	Input power	Effeciency
227V	0,867A	195,6W	18lm/W

## ISO CANDELA DIAGRAM

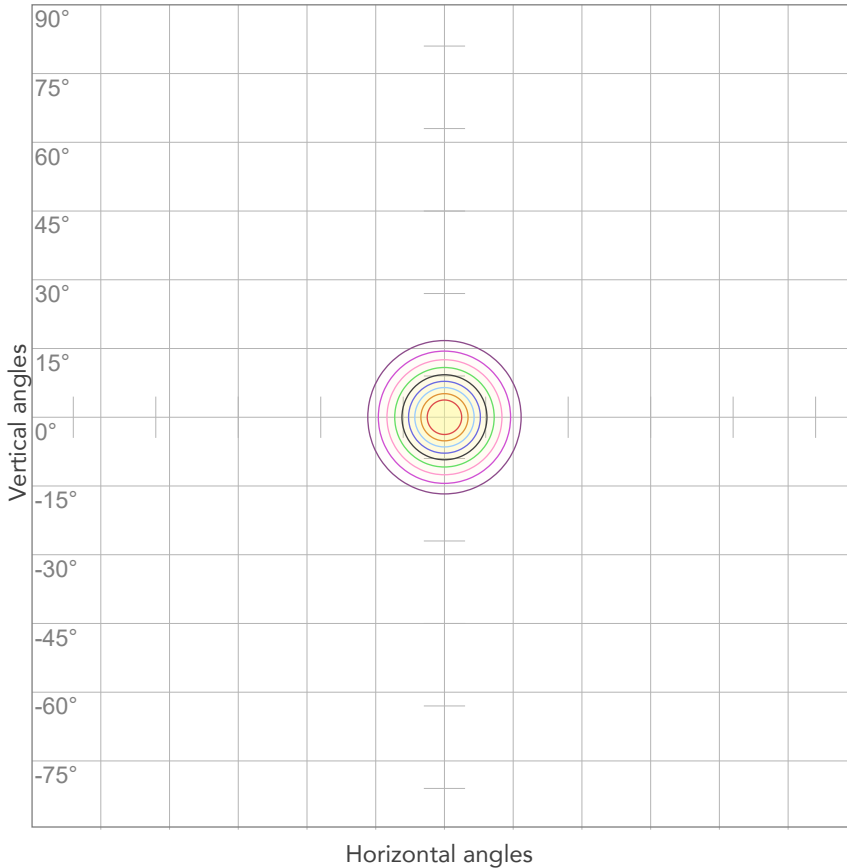

10%	2384 cd
20%	4768 cd
30%	7153 cd
40%	9537 cd
50%	11921 cd
60%	14305 cd
70%	16689 cd
80%	19074 cd

Conditions:

Number of c-planes: 2

Candela at center: 23842 cd

## ISO LUX DIAGRAM

MH: 10,0 m

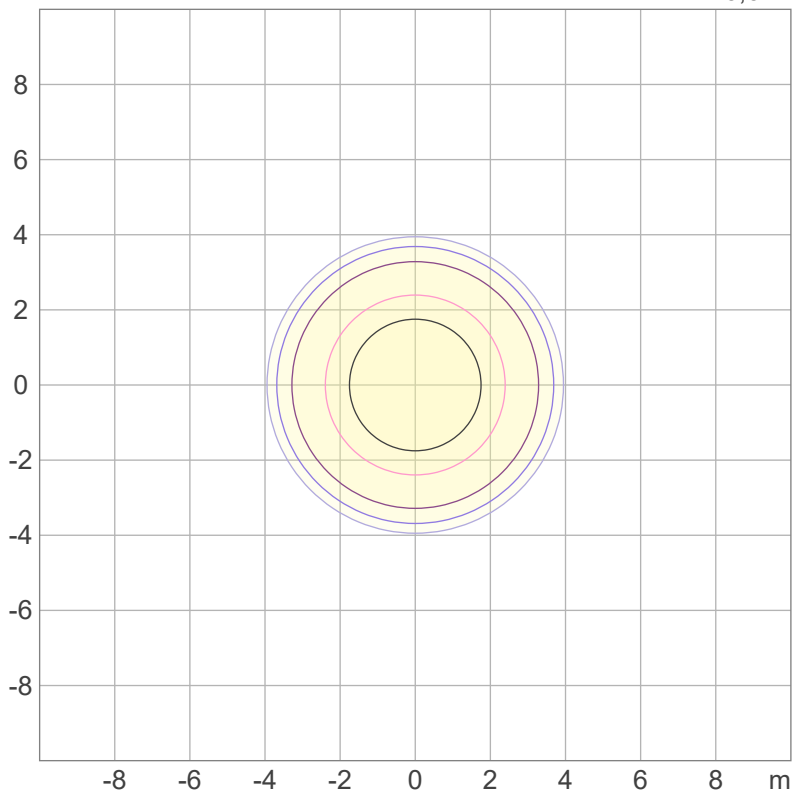

Mounting height: 10 meters (33 feet)

3%	7,15 lx
5%	11,9 lx
10%	23,8 lx
30%	71,5 lx
50%	119 lx

Conditions:

Number of c-planes: 2

Lux at center: 238 lx

*Lux distribution on a surface when lamp is mounted at 10 meters from the surface.*



Total lumen output:

1993 lm

Peak candela output:

56054 cd

Light quality:

CRI: 92,2

Color temperature:

5563 K

**PRODUCT NAME:**

ECLFRCTPS

**MEASURAMENT CONDITIONS:**

Beam angle:

Min Zoom

Target:

5600K - HB

Operator:

Salvatore Giglio

Date and time:

02/10/2023 16:27:23

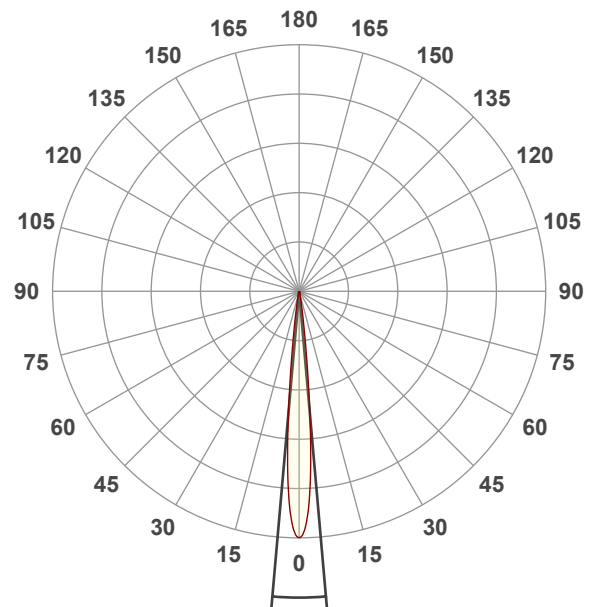

Beam angle 50%: 10°

Field angle 10%: 17°

Cut off angle 2.5%: 23,6°

Spectra

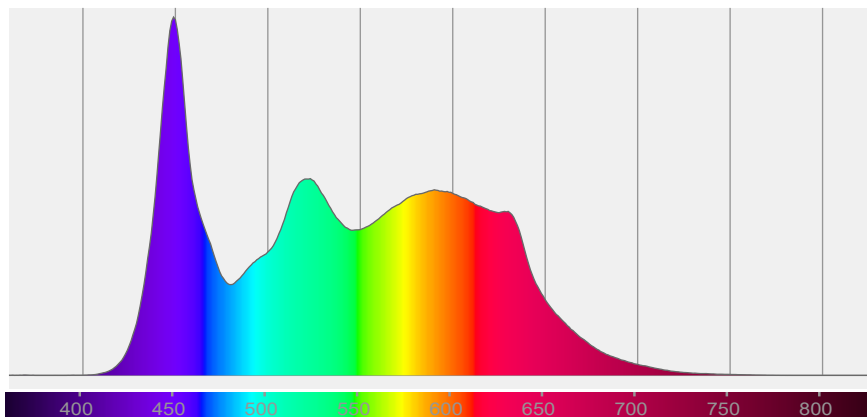

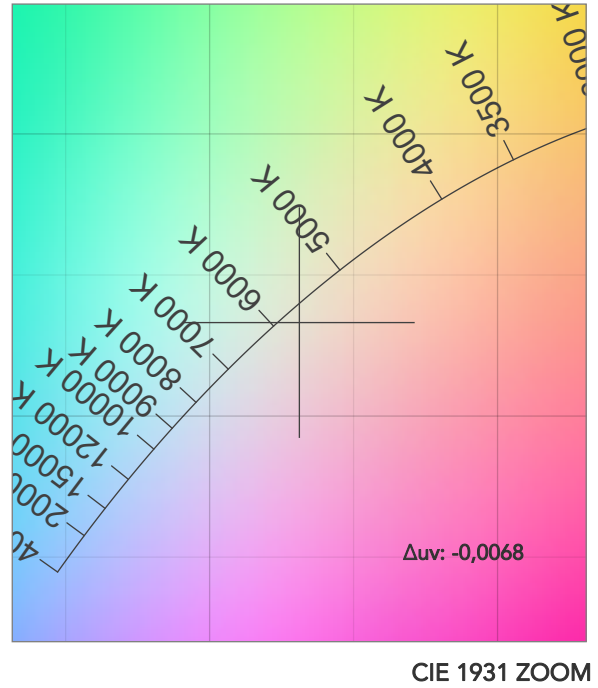
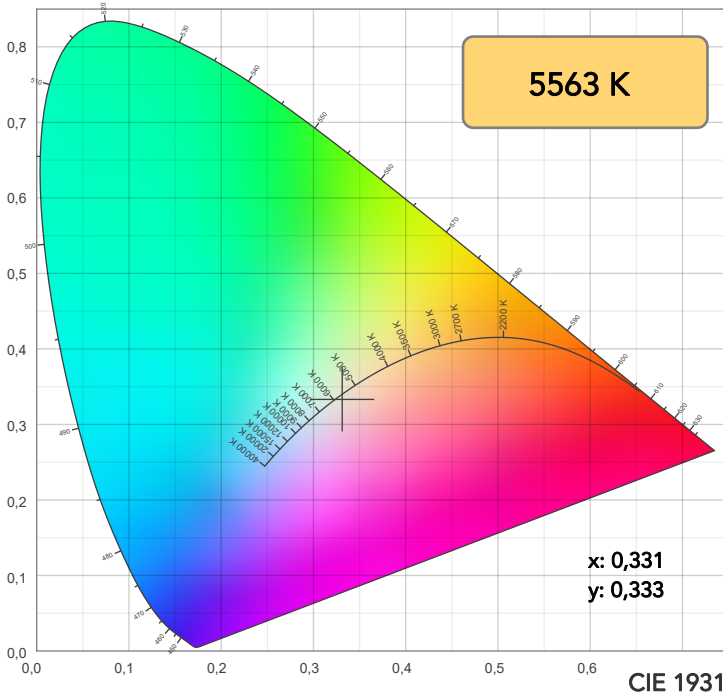

TM30: 89,2

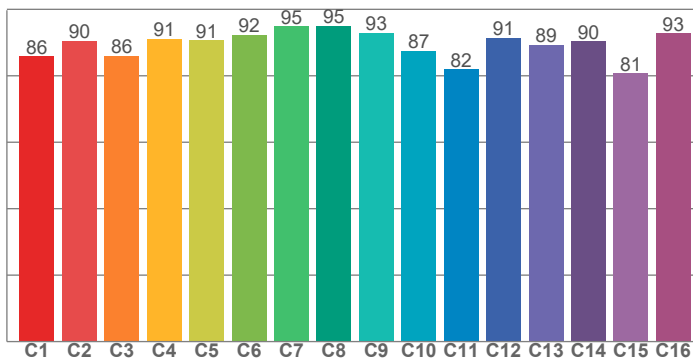

CRI: 92,2 (R1-R8)

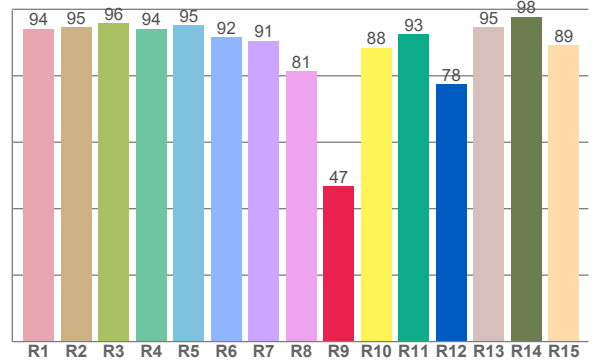

CQS: 88,5

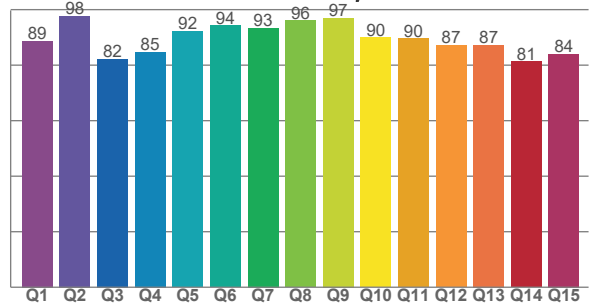

CRI R values, only R1-R8 are used to calculate final CRI value

R1	R2	R3	R4	R5	R6	R7	R8	R9	R10	R11	R12	R13	R14	R15
94,1	94,5	95,7	94,1	95,3	91,7	90,5	81,3	46,7	88,5	92,5	77,5	94,5	97,8	89,2

TM30 C values, 16 binned values out of total of 99 C values

C1	C2	C3	C4	C5	C6	C7	C8	C9	C10	C11	C12	C13	C14	C15	C16
85,8	90,5	85,9	91,1	90,7	92,4	94,9	95,0	92,9	87,5	81,9	91,4	89,3	90,3	80,7	92,8

CQS Q values

Q1	Q2	Q3	Q4	Q5	Q6	Q7	Q8	Q9	Q10	Q11	Q12	Q13	Q14	Q15
88,7	97,8	82,2	84,7	92,2	94,3	93,5	96,1	97,0	89,9	89,5	87,1	87,2	81,3	84,0

COLOR PARAMETERS

Color temperature	Color rendering index	Red component	Color fidelity	Color gamut	Color quality scale	Television lighting index	Color coordinate cie 1931	Color coordinate cie 1931	Color deviation from black body
CCT	CRI	CRI R9	TM30 Rf	TM30 Rg	CQS	TLCI	x	y	Δuv
5563 K	92,2	46,7	89,2	101,0	88,5	83	0,331	0,333	-0,0068

# TM30 DETAILS

**Rf 89,2**  
Fidelity index Rf

**Rg 101,0**  
Gammut index

Hue Bin	R <sub>f</sub>	Graphic shifts (%)	
		Chroma	Hue
1	86	-7%	-1%
2	90	-4%	5%
3	86	-2%	8%
4	91	1%	5%
5	91	2%	4%
6	92	5%	2%
7	95	2%	0%
8	95	-1%	0%
9	93	-3%	4%
10	87	-2%	7%
11	82	2%	11%
12	91	5%	3%
13	89	7%	-4%
14	90	4%	-4%
15	81	5%	-17%
16	93	-2%	-3%

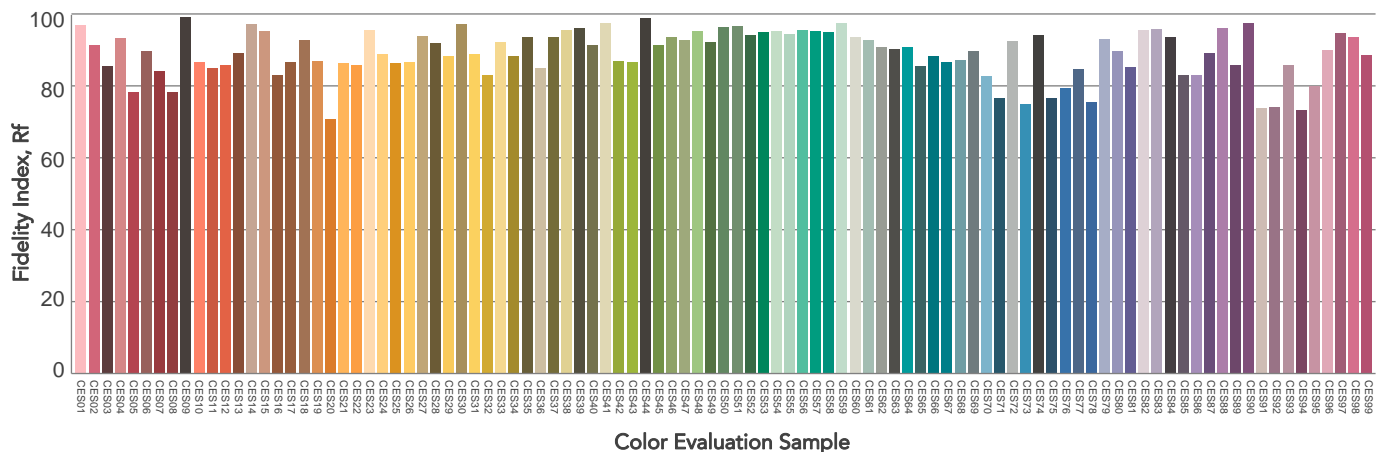
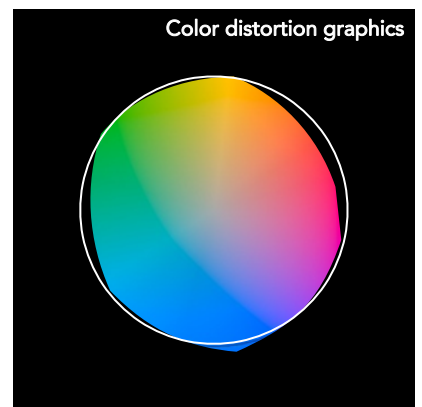
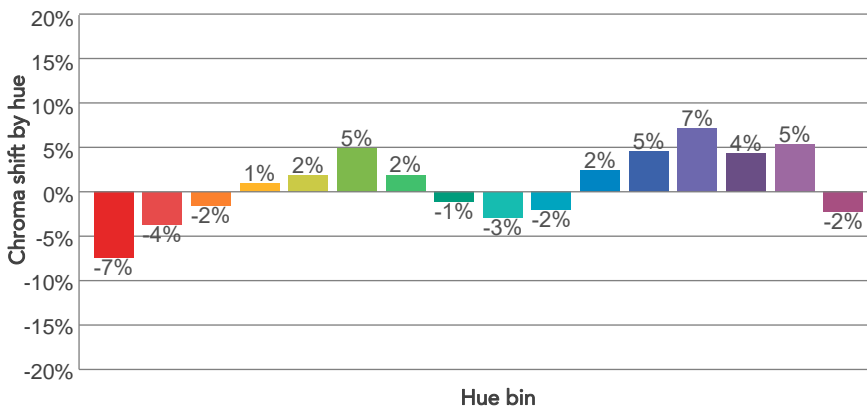
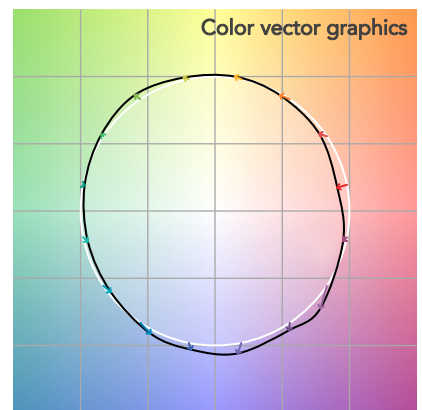
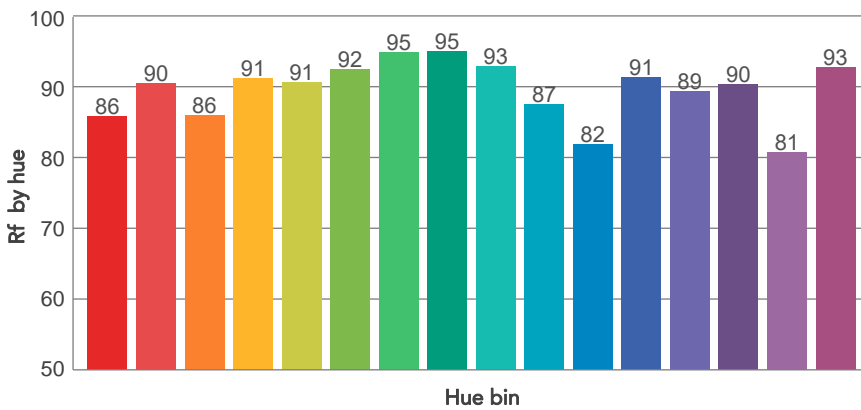
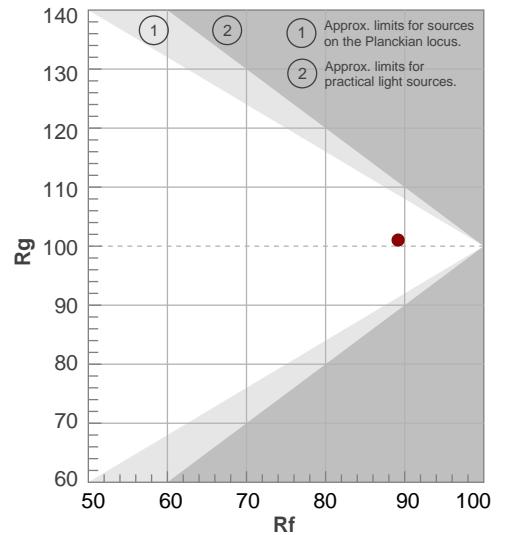

# BEAM DETAILS



Beam angle 50%	Field angle 10%	Cut off angle 2,5%	Intensity ratio in 120° cone	Intensity ratio in 90° cone
10°	17°	23,6°	100,0%	100,0%

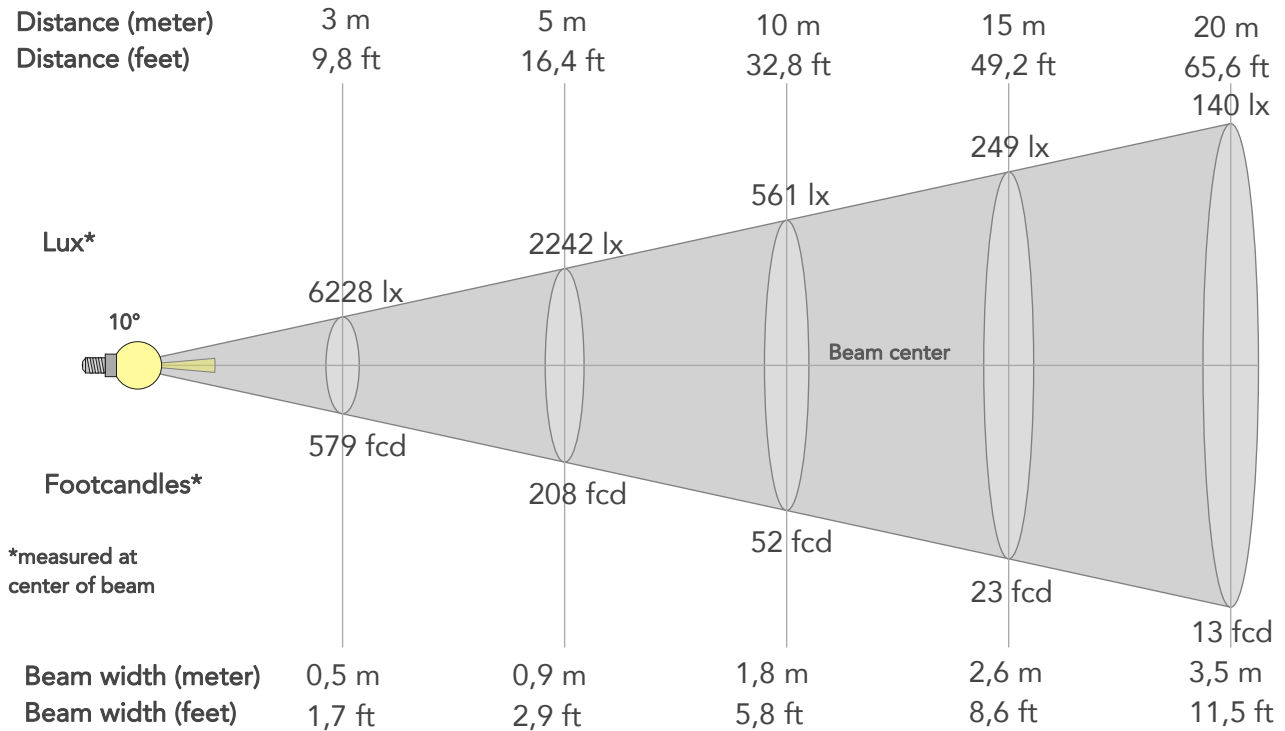

## BEAM INTENSITIES AND WIDTHS

Distance	1m	2m	3m	4m	5m	7,5m	10m	15m	20m	25m	30m	40m	50m
Distance	3,3ft	6,6ft	9,8ft	13,1ft	16,4ft	24,6ft	32,8ft	49,2ft	65,6ft	82ft	98,4ft	131,2ft	164ft
Lux	56054lx	14014lx	6228lx	3503lx	2242lx	997lx	561lx	249lx	140lx	90lx	62lx	35lx	22lx
Footcand.	5208fcd	1302fcd	579fcd	325fcd	208fcd	93fcd	52fcd	23fcd	13fcd	8fcd	6fcd	3fcd	2fcd
Beam wid.	0,2m	0,4m	0,5m	0,7m	0,9m	1,3m	1,8m	2,6m	3,5m	4,4m	5,3m	7m	8,8m
Beam wid.	0,6ft	1,2ft	1,7ft	2,3ft	2,9ft	4,3ft	5,8ft	8,6ft	11,5ft	14,4ft	17,3ft	23ft	28,8ft

## LINEAR DISTRIBUTION DIAGRAM

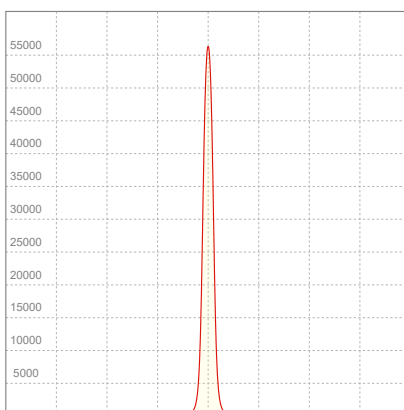

## ELECTRICAL SPECIFICATIONS

Input voltage	Input current	Input power	Effeciency
227V	0,869A	196W	10lm/W

## ISO CANDELA DIAGRAM

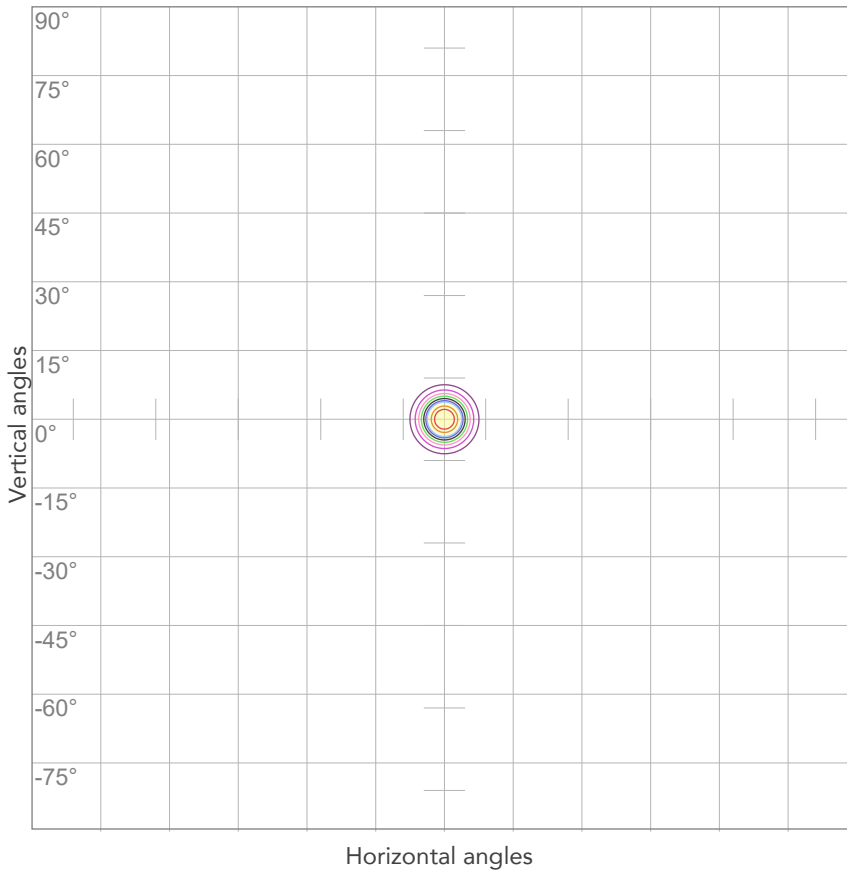

10%	5605 cd
20%	11211 cd
30%	16816 cd
40%	22422 cd
50%	28027 cd
60%	33633 cd
70%	39238 cd
80%	44843 cd

Conditions:

Number of c-planes: 2

Candela at center: 56054 cd

## ISO LUX DIAGRAM

MH: 10,0 m

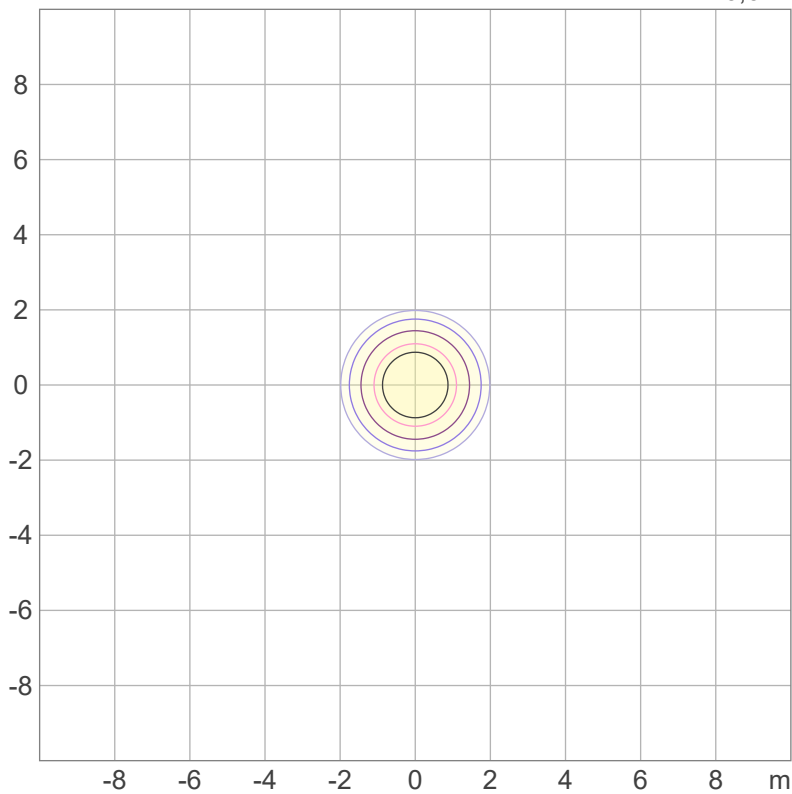

Mounting height: 10 meters (33 feet)

3%	16,8 lx
5%	28,0 lx
10%	56,1 lx
30%	168 lx
50%	280 lx

Conditions:

Number of c-planes: 2

Lux at center: 561 lx

*Lux distribution on a surface when lamp is mounted at 10 meters from the surface.*



Total lumen output:

4737 lm

Peak candela output:

7075 cd

Light quality:

CRI: 91,0

Color temperature:

6068 K

PRODUCT NAME:

ECLFRCTPS

MEASURAMENT CONDITIONS:

Beam angle:

Max Zoom

Target:

6000K - HB

Operator:

Salvatore Giglio

Date and time:

02/10/2023 16:59:09

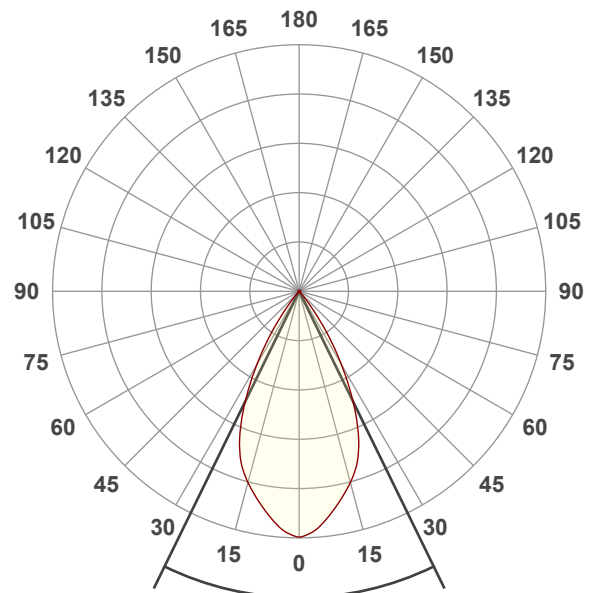

Beam angle 50%: 52,1°

Field angle 10%: 73,8°

Cut off angle 2.5%: 82,2°

Spectra

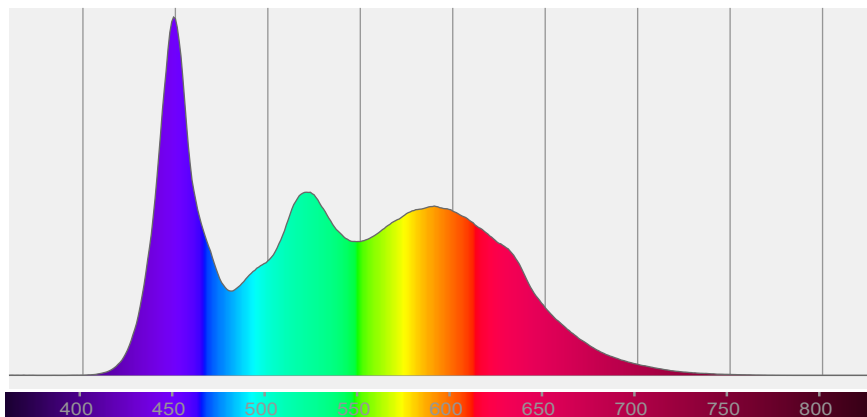



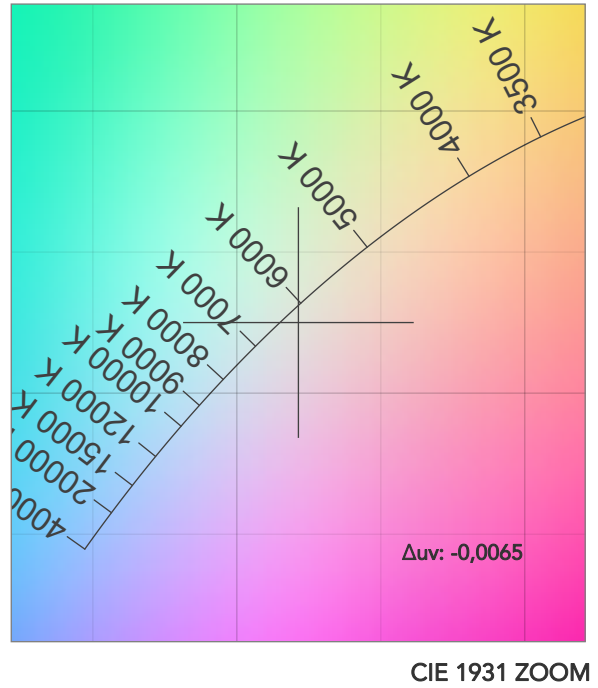
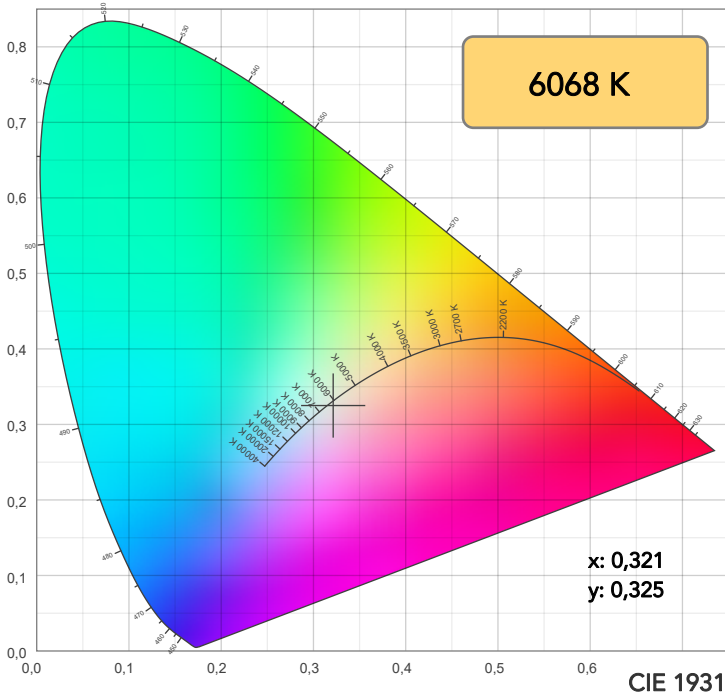

TM30: 88,1

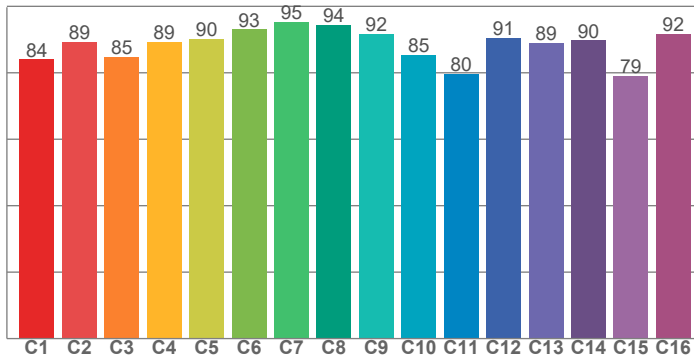

CRI: 91,0 (R1-R8)

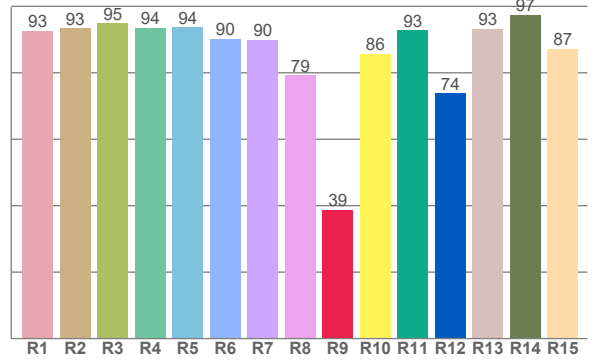

CQS: 87,1

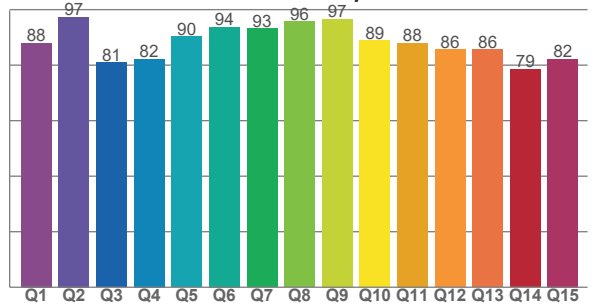

CRI R values, only R1-R8 are used to calculate final CRI value

R1	R2	R3	R4	R5	R6	R7	R8	R9	R10	R11	R12	R13	R14	R15
92,6	93,4	94,9	93,6	93,7	90,2	90,0	79,3	38,7	85,7	92,9	73,9	93,3	97,5	87,2

TM30 C values, 16 binned values out of total of 99 C values

C1	C2	C3	C4	C5	C6	C7	C8	C9	C10	C11	C12	C13	C14	C15	C16
84,0	89,3	84,7	89,3	90,3	93,1	95,3	94,3	91,7	85,3	79,7	90,5	89,0	89,7	79,1	91,8

CQS Q values

Q1	Q2	Q3	Q4	Q5	Q6	Q7	Q8	Q9	Q10	Q11	Q12	Q13	Q14	Q15
88,0	97,3	80,9	82,3	90,3	93,7	93,2	95,7	96,7	88,8	88,1	85,7	85,7	78,5	82,2

COLOR PARAMETERS

Color temperature	Color rendering index	Red component	Color fidelity	Color gamut	Color quality scale	Television lighting index	Color coordinate cie 1931	Color coordinate cie 1931	Color deviation from black body
CCT	CRI	CRI R9	TM30 Rf	TM30 Rg	CQS	TLCI	x	y	Δuv
6068 K	91,0	38,7	88,1	100,4	87,1	80	0,321	0,325	-0,0065

# TM30 DETAILS

**Rf 88,1**  
Fidelity index Rf

**Rg 100,4**  
Gammut index

Hue Bin	R <sub>f</sub>	Graphic shifts (%)	
		Chroma	Hue
1	84	-8%	-1%
2	89	-4%	5%
3	85	-2%	8%
4	89	1%	6%
5	90	1%	3%
6	93	4%	1%
7	95	3%	0%
8	94	-2%	0%
9	92	-4%	5%
10	85	-2%	8%
11	80	2%	12%
12	91	5%	4%
13	89	8%	-3%
14	90	4%	-4%
15	79	6%	-18%
16	92	-3%	-4%

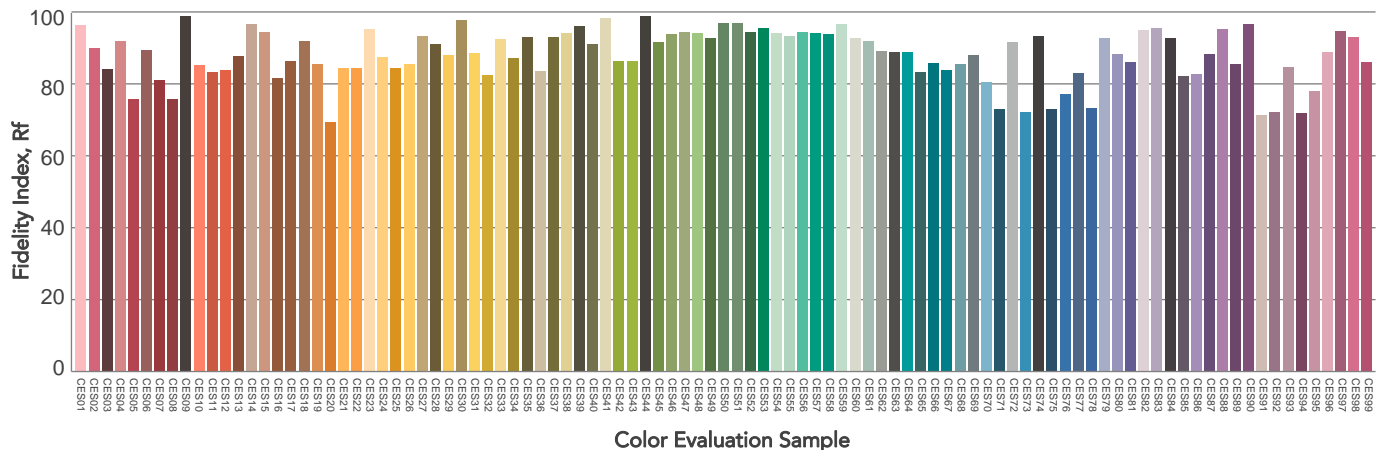
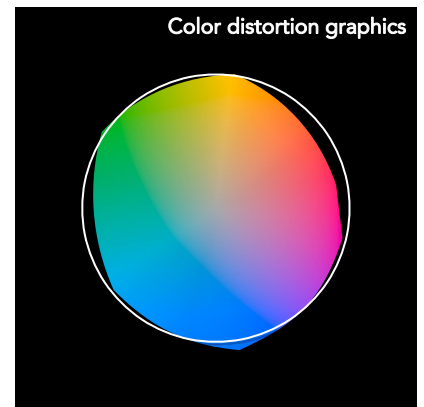
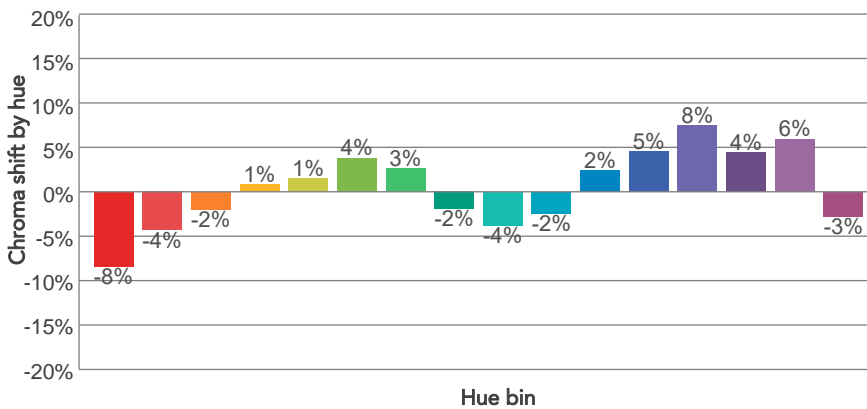
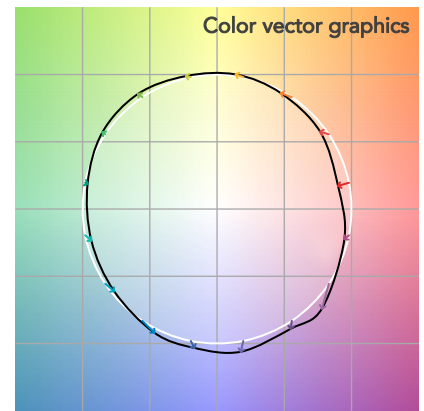
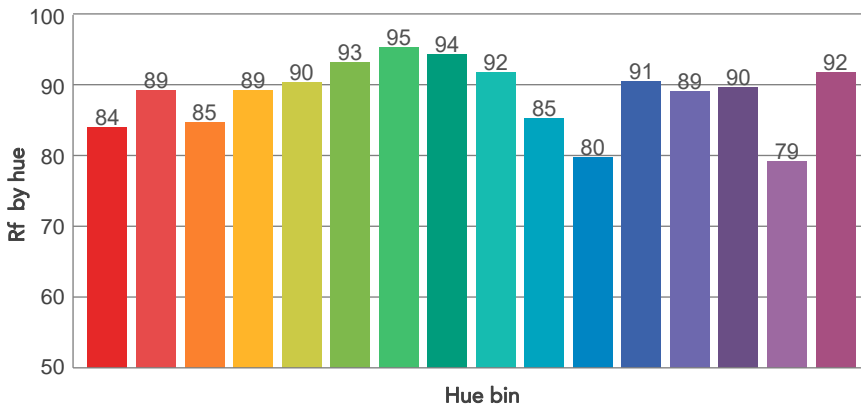
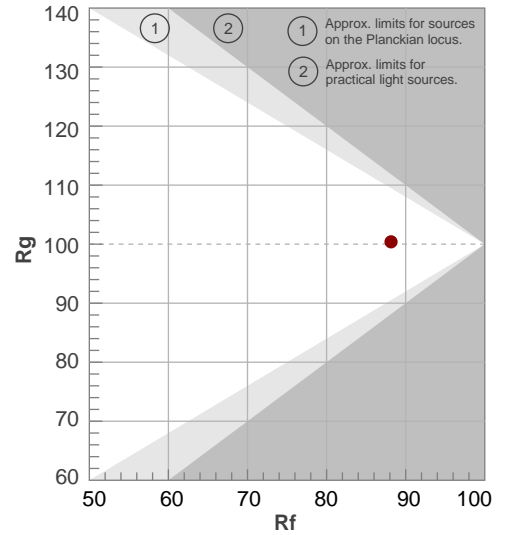

# BEAM DETAILS



Beam angle 50%	Field angle 10%	Cut off angle 2,5%	Intensity ratio in 120° cone	Intensity ratio in 90° cone
52,1°	73,8°	82,2°	100,0%	99,5%

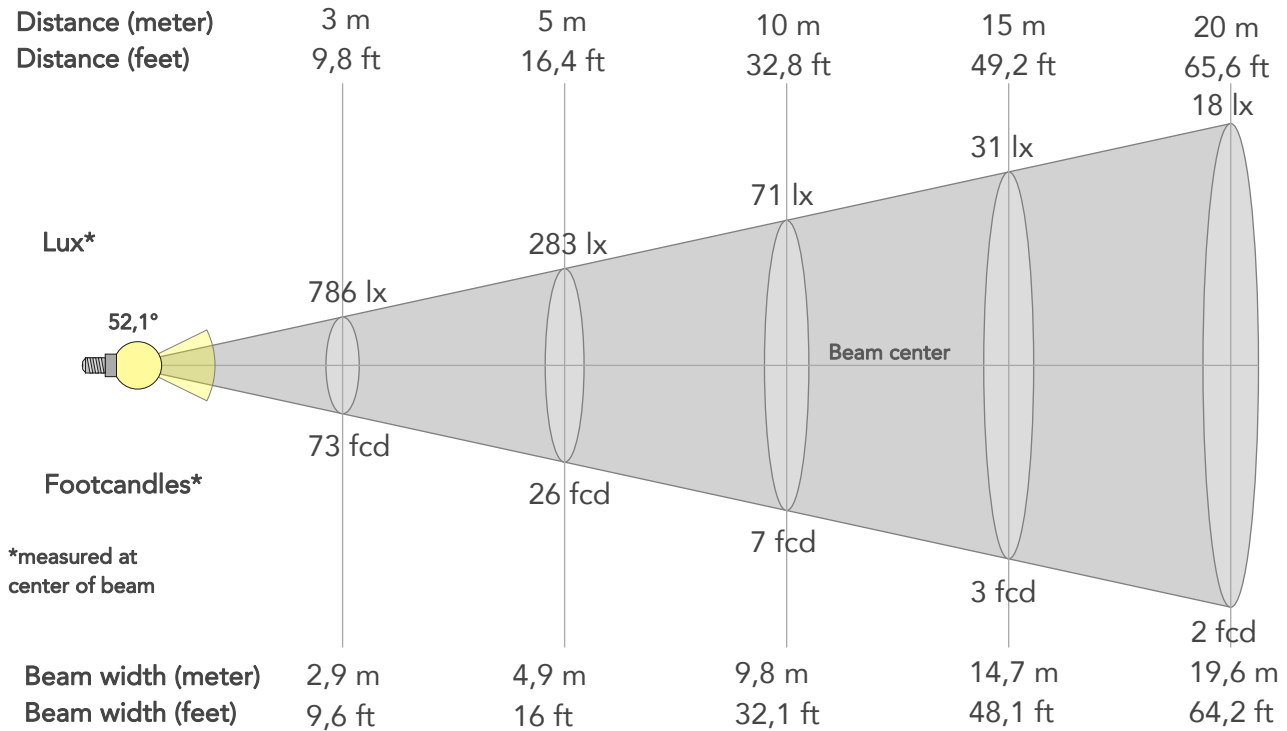

## BEAM INTENSITIES AND WIDTHS

Distance	1m	2m	3m	4m	5m	7,5m	10m	15m	20m	25m	30m	40m	50m
Distance	3,3ft	6,6ft	9,8ft	13,1ft	16,4ft	24,6ft	32,8ft	49,2ft	65,6ft	82ft	98,4ft	131,2ft	164ft
Lux	7075lx	1769lx	786lx	442lx	283lx	126lx	71lx	31lx	18lx	11lx	8lx	4lx	3lx
Footcand.	657fcd	164fcd	73fcd	41fcd	26fcd	12fcd	7fcd	3fcd	2fcd	1fcd	1fcd	0fcd	0fcd
Beam wid.	1m	2m	2,9m	3,9m	4,9m	7,3m	9,8m	14,7m	19,6m	24,5m	29,3m	39,1m	48,9m
Beam wid.	3,2ft	6,5ft	9,6ft	12,8ft	16ft	24,1ft	32,1ft	48,1ft	64,2ft	80,2ft	96,3ft	128,3ft	160,4ft

## LINEAR DISTRIBUTION DIAGRAM

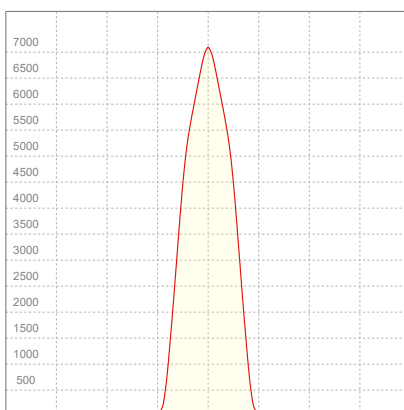

## ELECTRICAL SPECIFICATIONS

Input voltage	Input current	Input power	Effeciency
227V	0,863A	195W	24lm/W

## ISO CANDELA DIAGRAM

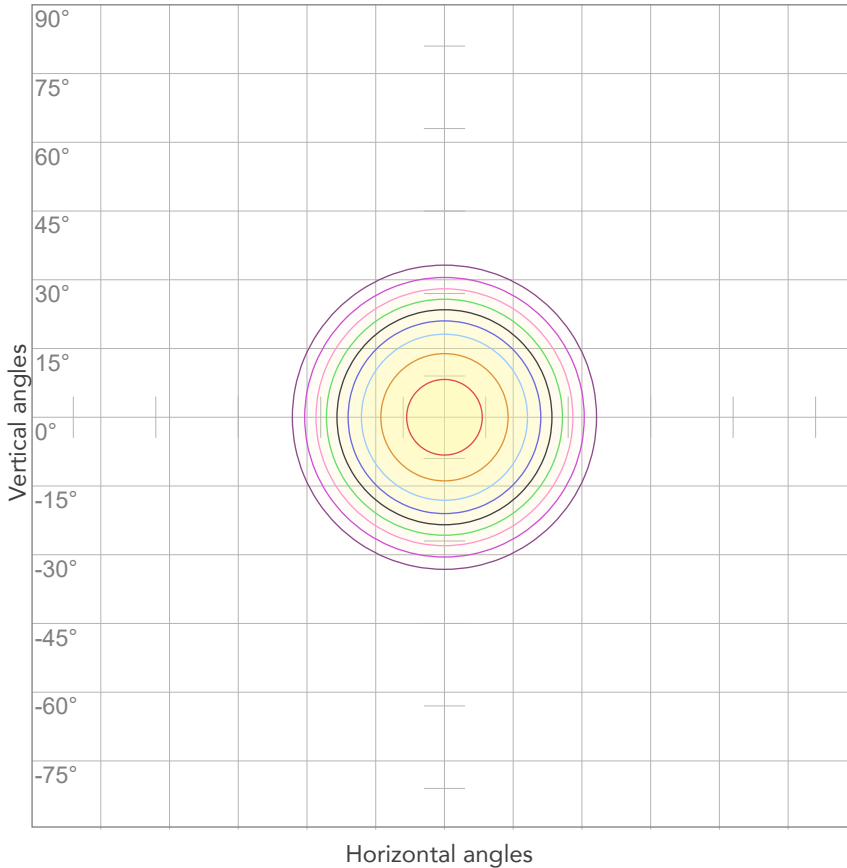

10%	708 cd
20%	1415 cd
30%	2123 cd
40%	2830 cd
50%	3538 cd
60%	4245 cd
70%	4953 cd
80%	5660 cd

Conditions:

Number of c-planes: 2

Candela at center: 7075 cd

## ISO LUX DIAGRAM

MH: 10,0 m

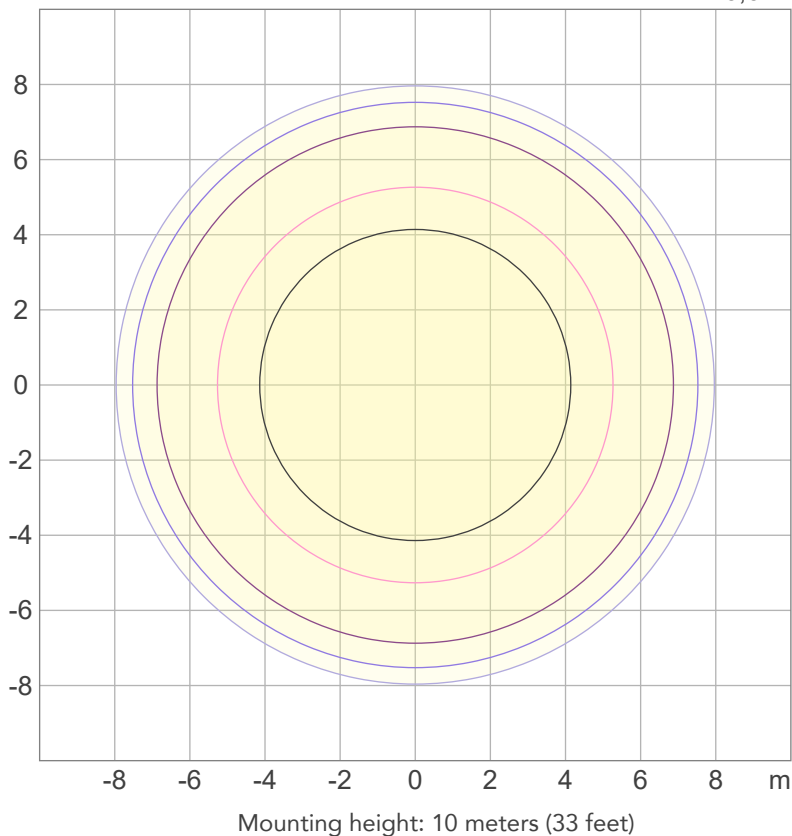

3%	2,12 lx
5%	3,54 lx
10%	7,08 lx
30%	21,2 lx
50%	35,4 lx

Conditions:

Number of c-planes: 2

Lux at center: 70,8 lx

*Lux distribution on a surface when lamp is mounted at 10 meters from the surface.*



Total lumen output:

3510 lm

Peak candela output:

23616 cd

Light quality:

CRI: 90,8

Color temperature:

6013 K

PRODUCT NAME:

ECLFRCTPS

MEASURAMENT CONDITIONS:

Beam angle:

Med Zoom

Target:

6000K - HB

Operator:

Salvatore Giglio

Date and time:

02/10/2023 17:08:27

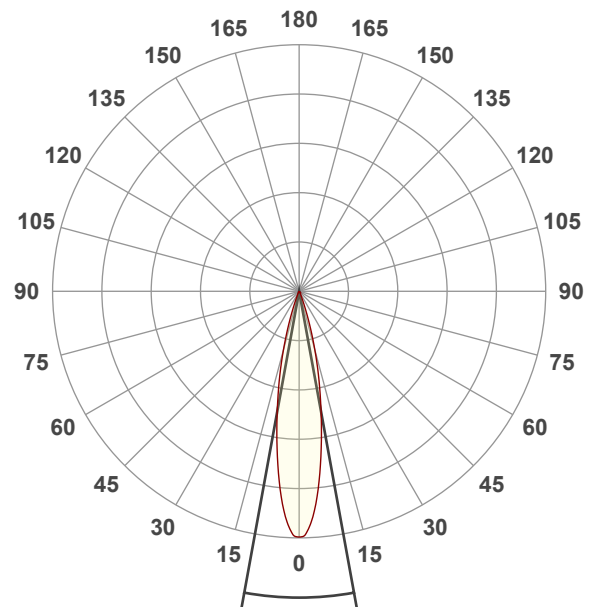

Beam angle 50%: 20,6°

Field angle 10%: 37,3°

Cut off angle 2.5%: 45,8°

Spectra

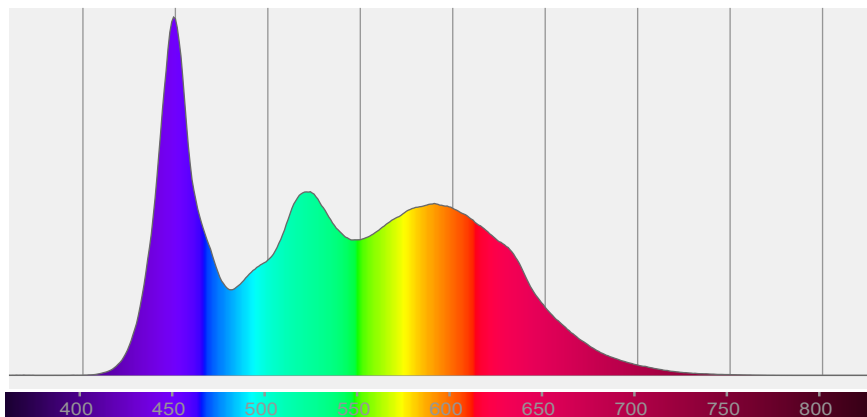

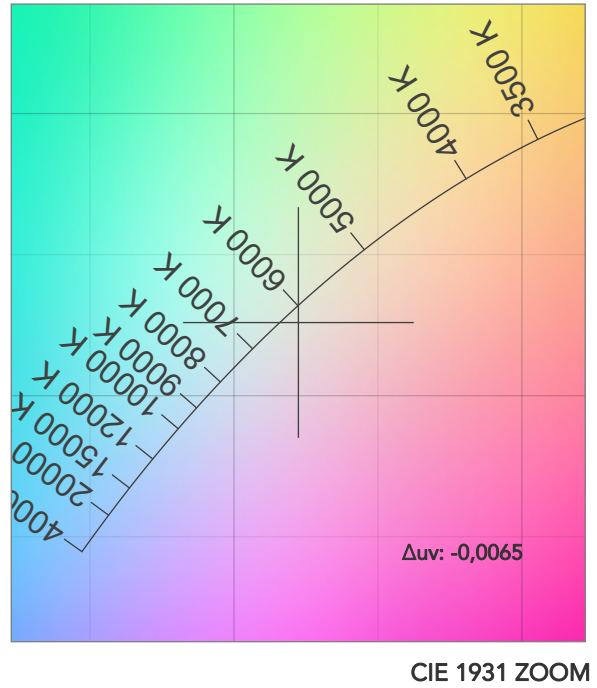
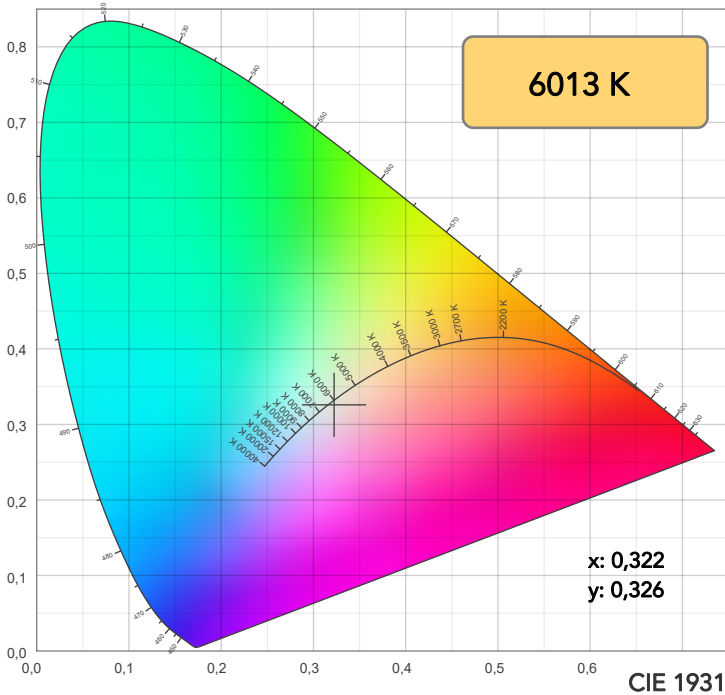

**TM30: 88,0**

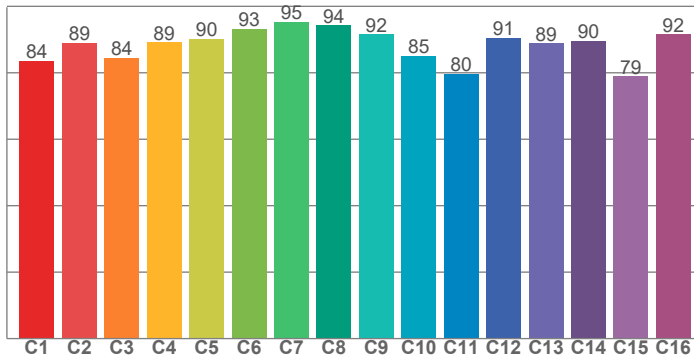

**CRI: 90,8 (R1-R8)**

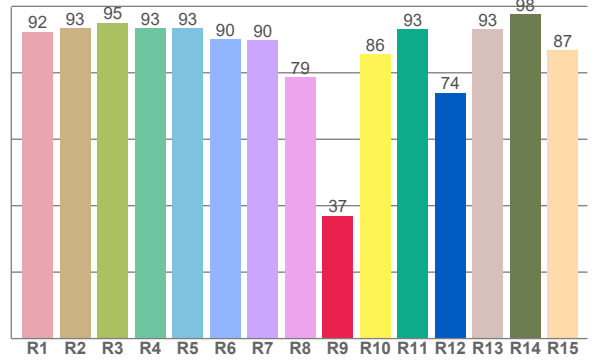

**CQS: 86,8**

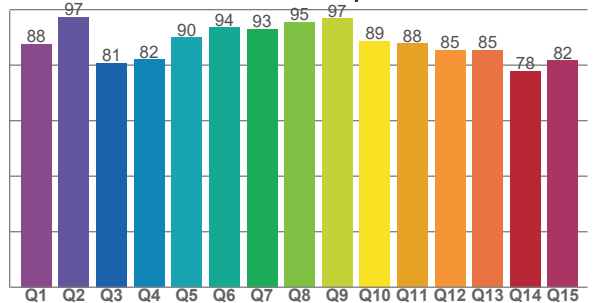

CRI R values, only R1-R8 are used to calculate final CRI value

R1	R2	R3	R4	R5	R6	R7	R8	R9	R10	R11	R12	R13	R14	R15
92,3	93,4	95,1	93,5	93,4	90,2	89,8	78,6	37,0	85,6	93,2	74,0	93,1	97,6	86,8

TM30 C values, 16 binned values out of total of 99 C values

C1	C2	C3	C4	C5	C6	C7	C8	C9	C10	C11	C12	C13	C14	C15	C16
83,6	89,0	84,5	89,2	90,3	93,2	95,4	94,2	91,6	85,1	79,7	90,6	88,9	89,5	78,9	91,5

CQS Q values

Q1	Q2	Q3	Q4	Q5	Q6	Q7	Q8	Q9	Q10	Q11	Q12	Q13	Q14	Q15
87,6	97,4	80,8	82,1	90,0	93,5	93,1	95,4	96,8	88,8	87,8	85,3	85,3	78,0	81,7

**COLOR PARAMETERS**

Color temperature	Color rendering index	Red component	Color fidelity	Color gamut	Color quality scale	Television lighting index	Color coordinate cie 1931	Color coordinate cie 1931	Color deviation from black body
CCT	CRI	CRI R9	TM30 Rf	TM30 Rg	CQS	TLCI	x	y	Δuv
6013 K	90,8	37,0	88,0	100,2	86,8	79	0,322	0,326	-0,0065

# TM30 DETAILS

**Rf 88,0**  
Fidelity index Rf

**Rg 100,2**  
Gammut index

Hue Bin	R <sub>f</sub>	Graphic shifts (%)	
		Chroma	Hue
1	84	-9%	-1%
2	89	-4%	5%
3	84	-2%	9%
4	89	1%	6%
5	90	1%	3%
6	93	4%	1%
7	95	2%	0%
8	94	-2%	0%
9	92	-4%	5%
10	85	-2%	8%
11	80	2%	12%
12	91	5%	3%
13	89	8%	-4%
14	90	4%	-4%
15	79	6%	-18%
16	92	-3%	-4%

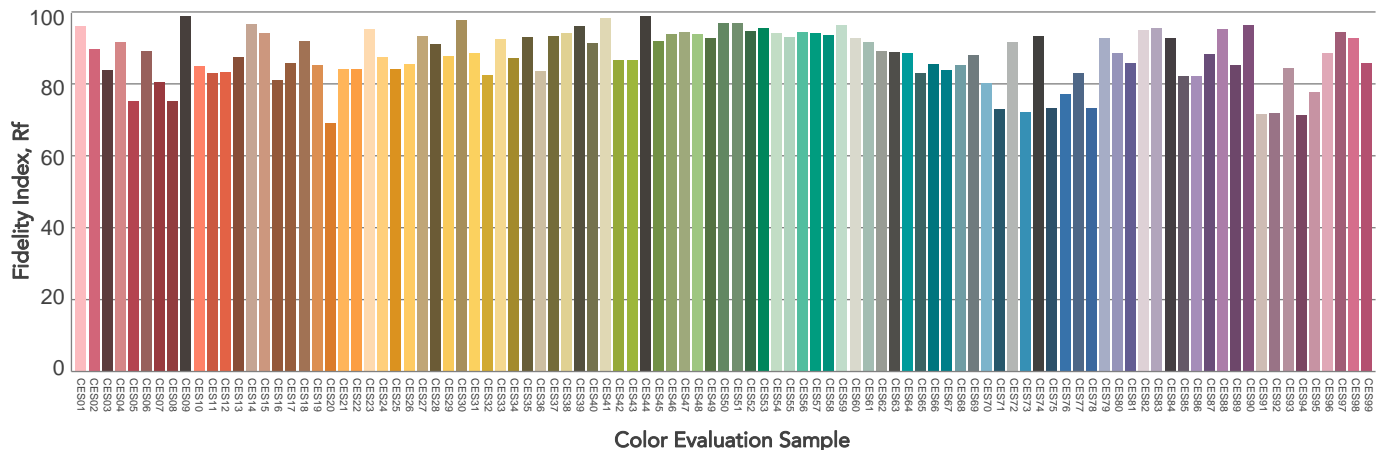
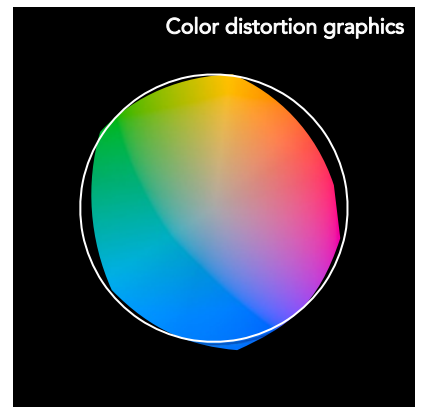
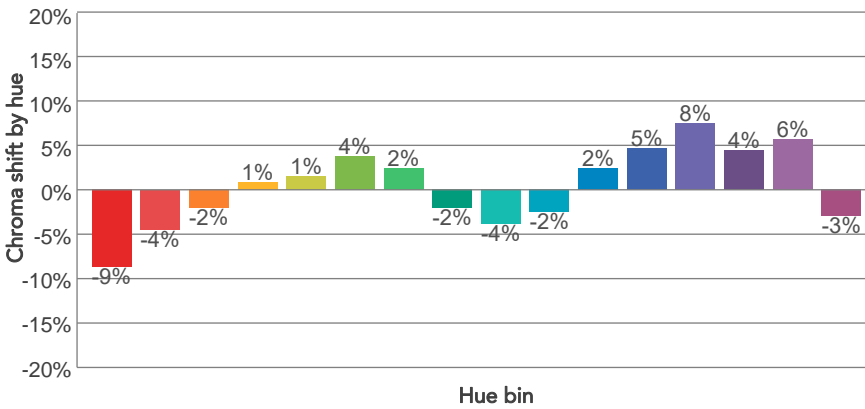
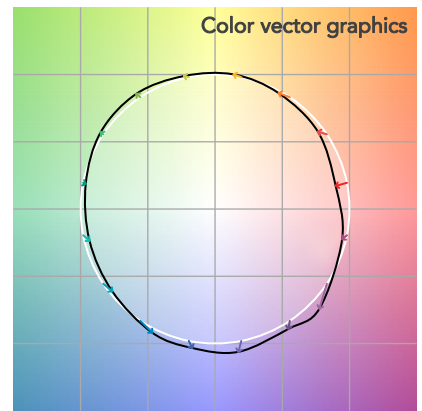
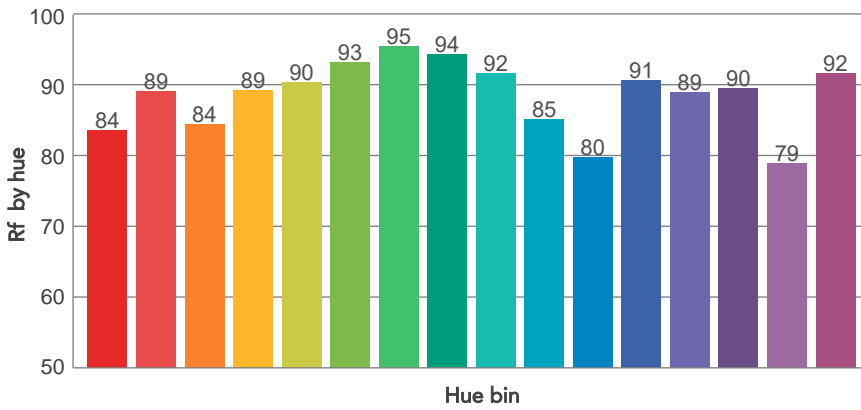
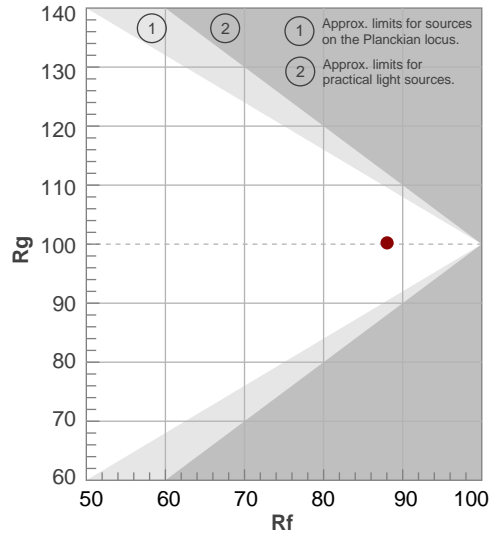

# BEAM DETAILS



Beam angle 50%	Field angle 10%	Cut off angle 2,5%	Intensity ratio in 120° cone	Intensity ratio in 90° cone
20,6°	37,3°	45,8°	100,0%	99,9%

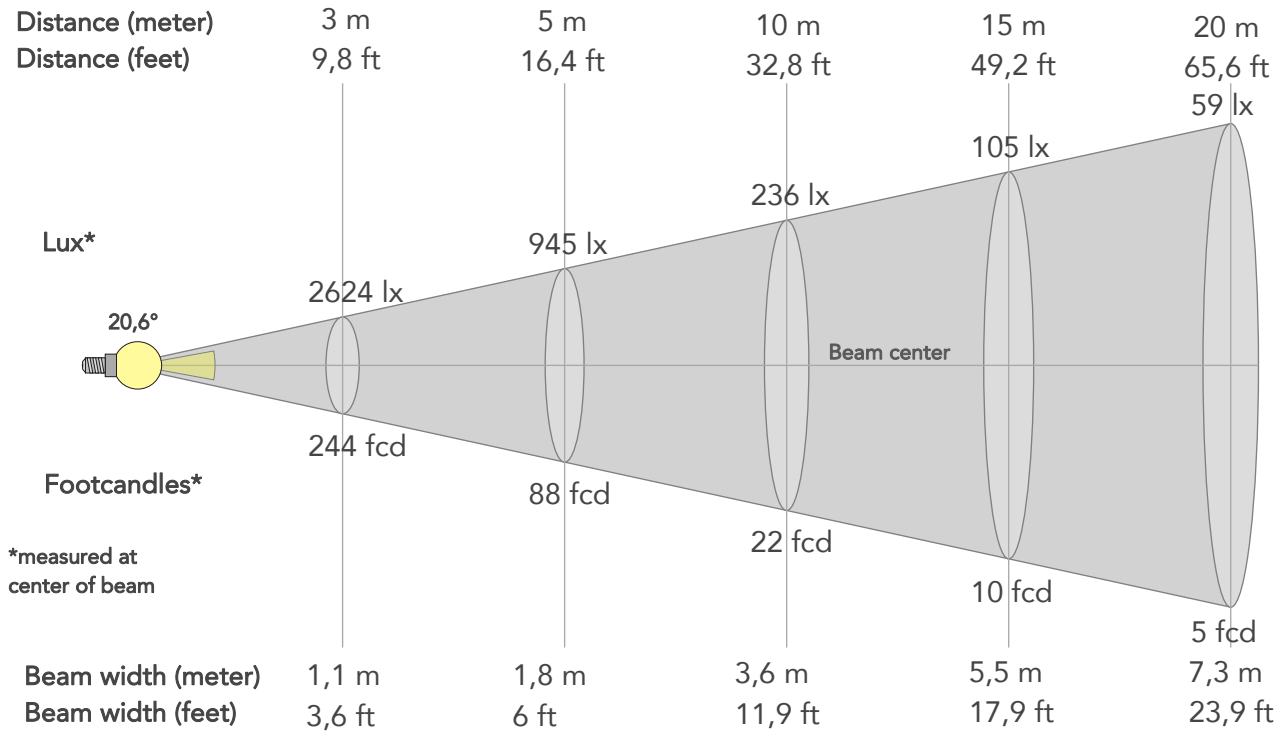

## BEAM INTENSITIES AND WIDTHS

Distance	1m	2m	3m	4m	5m	7,5m	10m	15m	20m	25m	30m	40m	50m
Distance	3,3ft	6,6ft	9,8ft	13,1ft	16,4ft	24,6ft	32,8ft	49,2ft	65,6ft	82ft	98,4ft	131,2ft	164ft
Lux	23616lx	5904lx	2624lx	1476lx	945lx	420lx	236lx	105lx	59lx	38lx	26lx	15lx	9lx
Footcand.	2194fcd	549fcd	244fcd	137fcd	88fcd	39fcd	22fcd	10fcd	5fcd	4fcd	2fcd	1fcd	1fcd
Beam wid.	0,4m	0,7m	1,1m	1,5m	1,8m	2,7m	3,6m	5,5m	7,3m	9,1m	10,9m	14,6m	18,2m
Beam wid.	1,2ft	2,4ft	3,6ft	4,8ft	6ft	9ft	11,9ft	17,9ft	23,9ft	29,9ft	35,8ft	47,8ft	59,7ft

## LINEAR DISTRIBUTION DIAGRAM

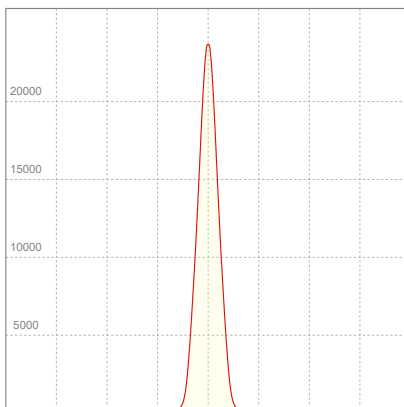

## ELECTRICAL SPECIFICATIONS

Input voltage	Input current	Input power	Effeciency
226V	0,866A	195W	18lm/W



## ISO CANDELA DIAGRAM

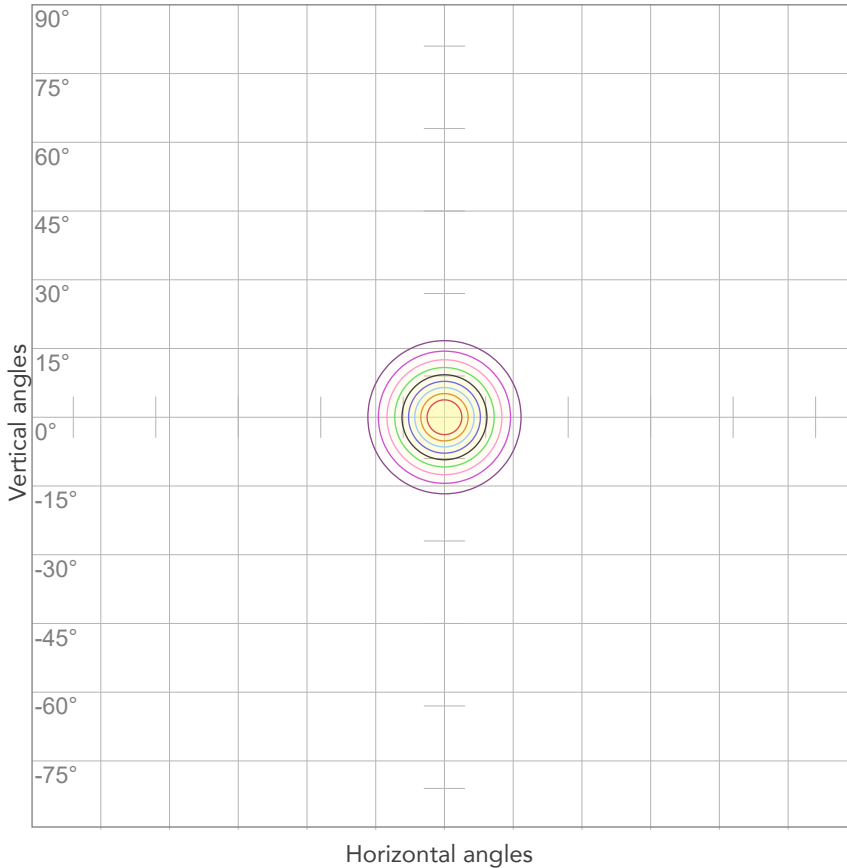

10%	2362 cd
20%	4723 cd
30%	7085 cd
40%	9447 cd
50%	11808 cd
60%	14170 cd
70%	16531 cd
80%	18893 cd

Conditions:

Number of c-planes: 2

Candela at center: 23616 cd

## ISO LUX DIAGRAM

MH: 10,0 m

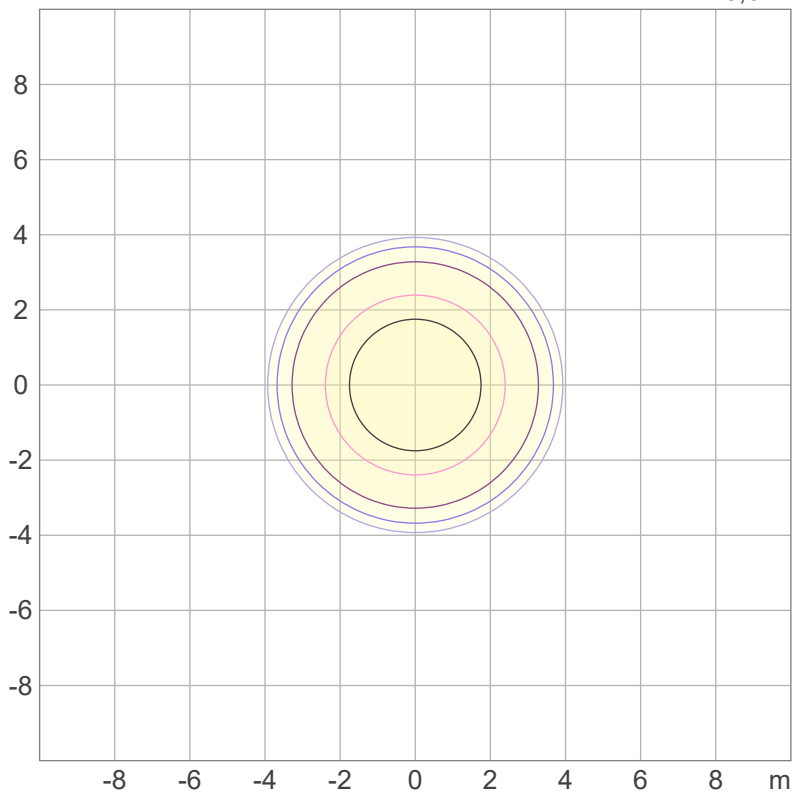

Mounting height: 10 meters (33 feet)

3%	7,08 lx
5%	11,8 lx
10%	23,6 lx
30%	70,8 lx
50%	118 lx

Conditions:

Number of c-planes: 2

Lux at center: 236 lx

*Lux distribution on a surface when lamp is mounted at 10 meters from the surface.*



Total lumen output:

1978 lm

Peak candela output:

56143 cd

Light quality:

CRI: 90,9

Color temperature:

6096 K

PRODUCT NAME:

ECLFRCTPS

MEASURAMENT CONDITIONS:

Beam angle:

Min Zoom

Target:

6000K - HB

Operator:

Salvatore Giglio

Date and time:

02/10/2023 16:29:00

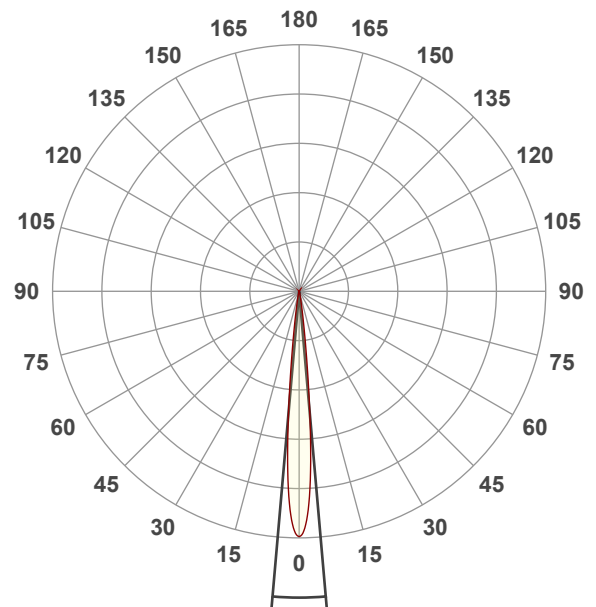

Beam angle 50%: 10°

Field angle 10%: 16,9°

Cut off angle 2.5%: 23,5°

Spectra

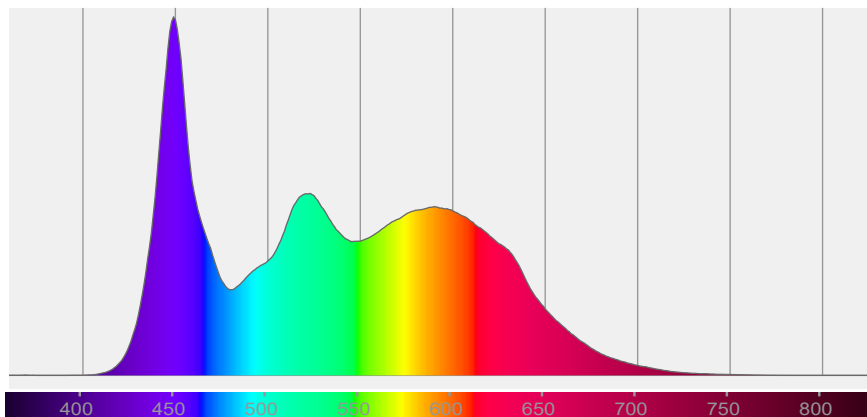

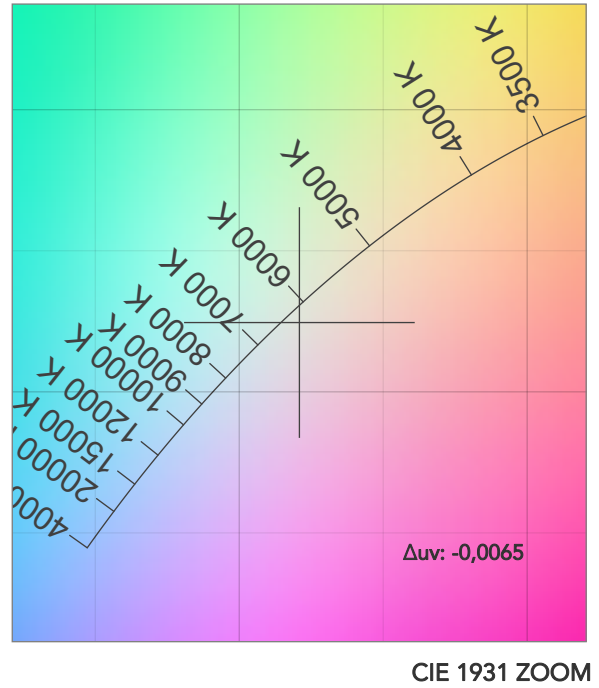
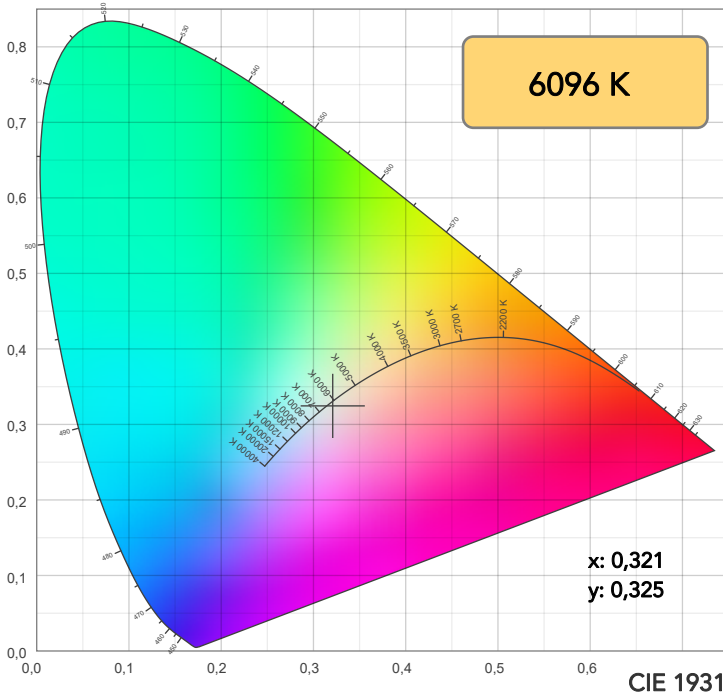

TM30: 88,0

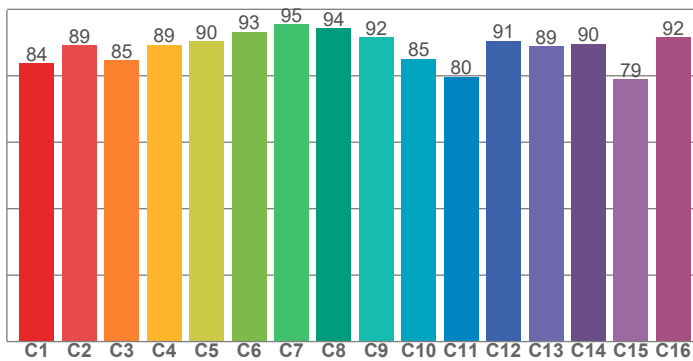

CRI: 90,9 (R1-R8)

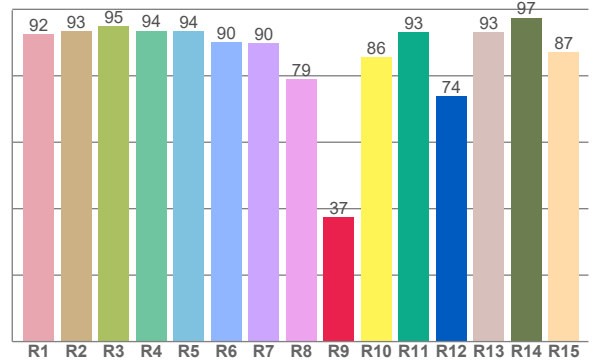

CQS: 86,9

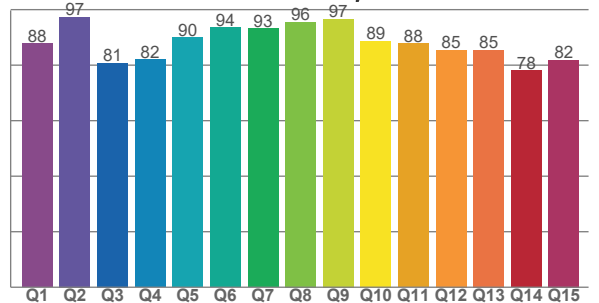

CRI R values, only R1-R8 are used to calculate final CRI value

R1	R2	R3	R4	R5	R6	R7	R8	R9	R10	R11	R12	R13	R14	R15
92,5	93,4	95,0	93,6	93,5	90,1	89,9	78,9	37,5	85,6	93,2	73,9	93,2	97,5	87,0

TM30 C values, 16 binned values out of total of 99 C values

C1	C2	C3	C4	C5	C6	C7	C8	C9	C10	C11	C12	C13	C14	C15	C16
83,7	89,1	84,6	89,2	90,3	93,3	95,4	94,2	91,5	85,0	79,6	90,6	88,9	89,6	78,9	91,6

CQS Q values

Q1	Q2	Q3	Q4	Q5	Q6	Q7	Q8	Q9	Q10	Q11	Q12	Q13	Q14	Q15
87,7	97,4	80,8	82,0	90,0	93,6	93,2	95,5	96,7	88,7	87,8	85,4	85,4	78,1	81,8

COLOR PARAMETERS

Color temperature	Color rendering index	Red component	Color fidelity	Color gamut	Color quality scale	Television lighting index	Color coordinate cie 1931	Color coordinate cie 1931	Color deviation from black body
CCT	CRI	CRI R9	TM30 Rf	TM30 Rg	CQS	TLCI	x	y	Δuv
6096 K	90,9	37,5	88,0	100,2	86,9	79	0,321	0,325	-0,0065

# TM30 DETAILS

**Rf 88,0**  
Fidelity index Rf

**Rg 100,2**  
Gammut index

Hue Bin	R <sub>f</sub>	Graphic shifts (%)	
		Chroma	Hue
1	84	-9%	-1%
2	89	-4%	5%
3	85	-2%	8%
4	89	1%	6%
5	90	1%	3%
6	93	4%	1%
7	95	2%	0%
8	94	-2%	0%
9	92	-4%	5%
10	85	-2%	8%
11	80	2%	12%
12	91	5%	4%
13	89	8%	-4%
14	90	4%	-4%
15	79	6%	-18%
16	92	-3%	-4%

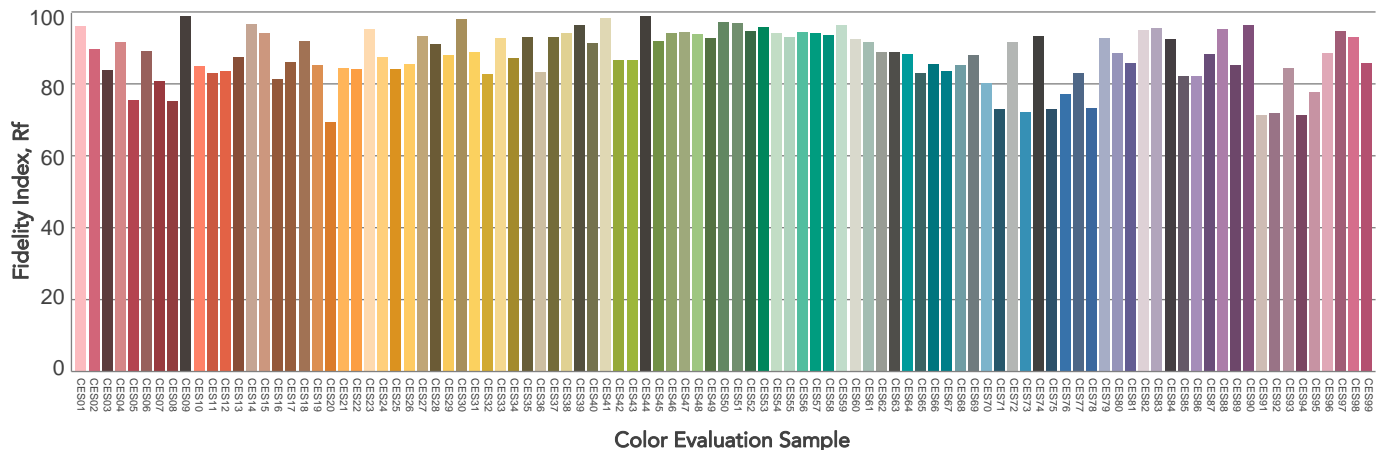
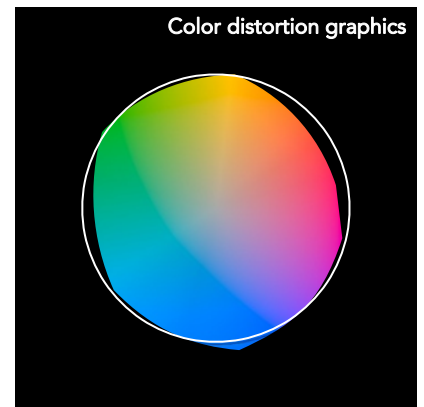
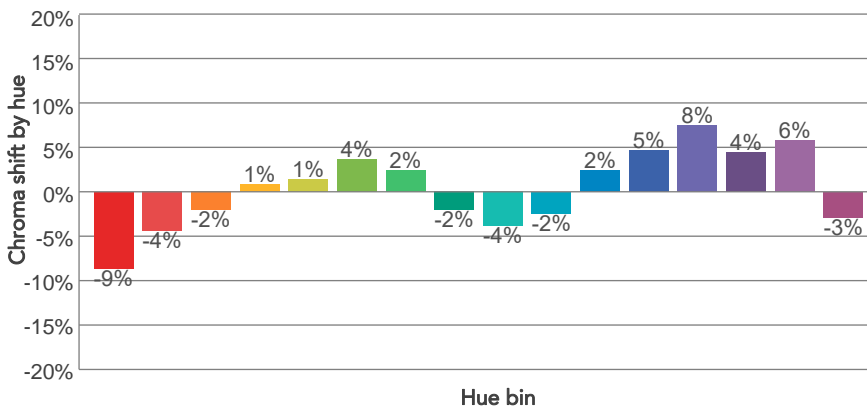
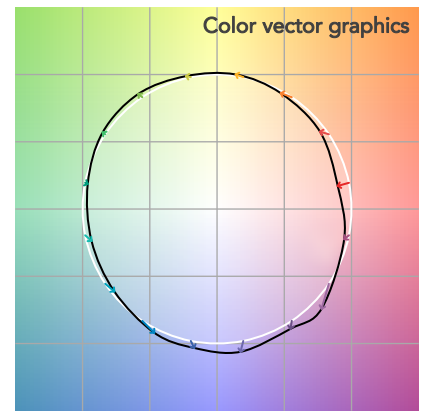
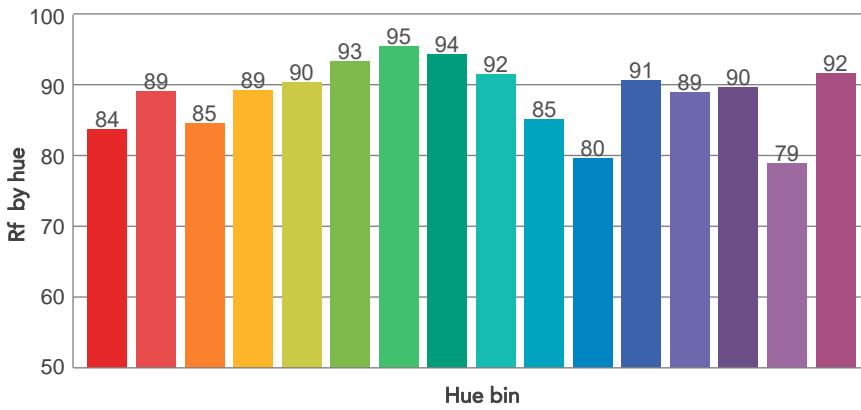
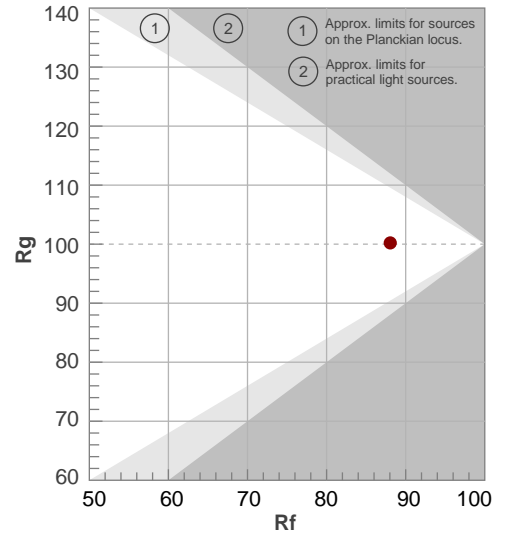

# BEAM DETAILS



Beam angle 50%	Field angle 10%	Cut off angle 2,5%	Intensity ratio in 120° cone	Intensity ratio in 90° cone
10°	16,9°	23,5°	100,0%	100,0%

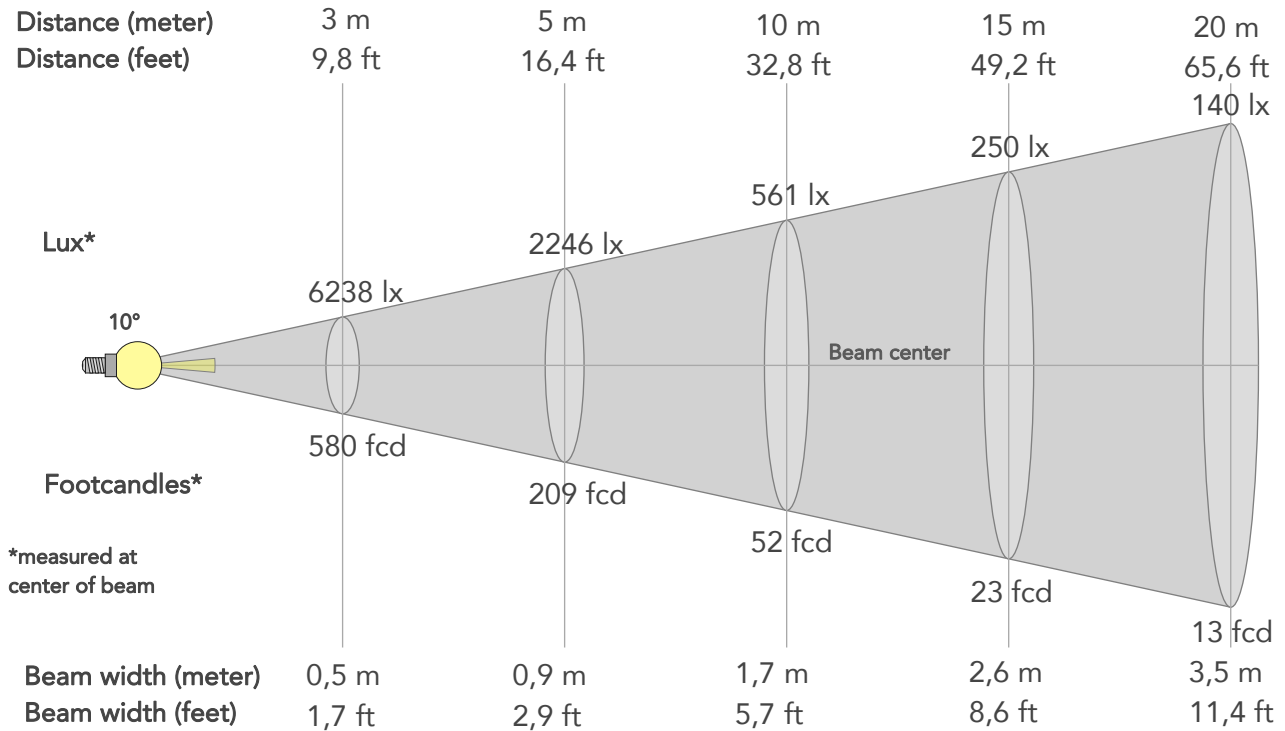

## BEAM INTENSITIES AND WIDTHS

Distance	1m	2m	3m	4m	5m	7,5m	10m	15m	20m	25m	30m	40m	50m
Distance	3,3ft	6,6ft	9,8ft	13,1ft	16,4ft	24,6ft	32,8ft	49,2ft	65,6ft	82ft	98,4ft	131,2ft	164ft
Lux	56143lx	14036lx	6238lx	3509lx	2246lx	998lx	561lx	250lx	140lx	90lx	62lx	35lx	22lx
Footcand.	5216fcd	1304fcd	580fcd	326fcd	209fcd	93fcd	52fcd	23fcd	13fcd	8fcd	6fcd	3fcd	2fcd
Beam wid.	0,2m	0,3m	0,5m	0,7m	0,9m	1,3m	1,7m	2,6m	3,5m	4,4m	5,2m	7m	8,7m
Beam wid.	0,6ft	1,2ft	1,7ft	2,3ft	2,9ft	4,3ft	5,7ft	8,6ft	11,4ft	14,3ft	17,2ft	22,9ft	28,6ft

## LINEAR DISTRIBUTION DIAGRAM

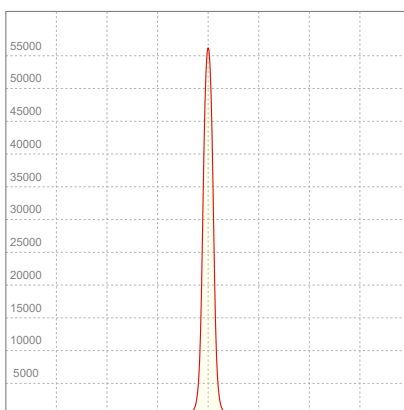

## ELECTRICAL SPECIFICATIONS

Input voltage	Input current	Input power	Effeciency
227V	0,868A	195,8W	10lm/W

## ISO CANDELA DIAGRAM

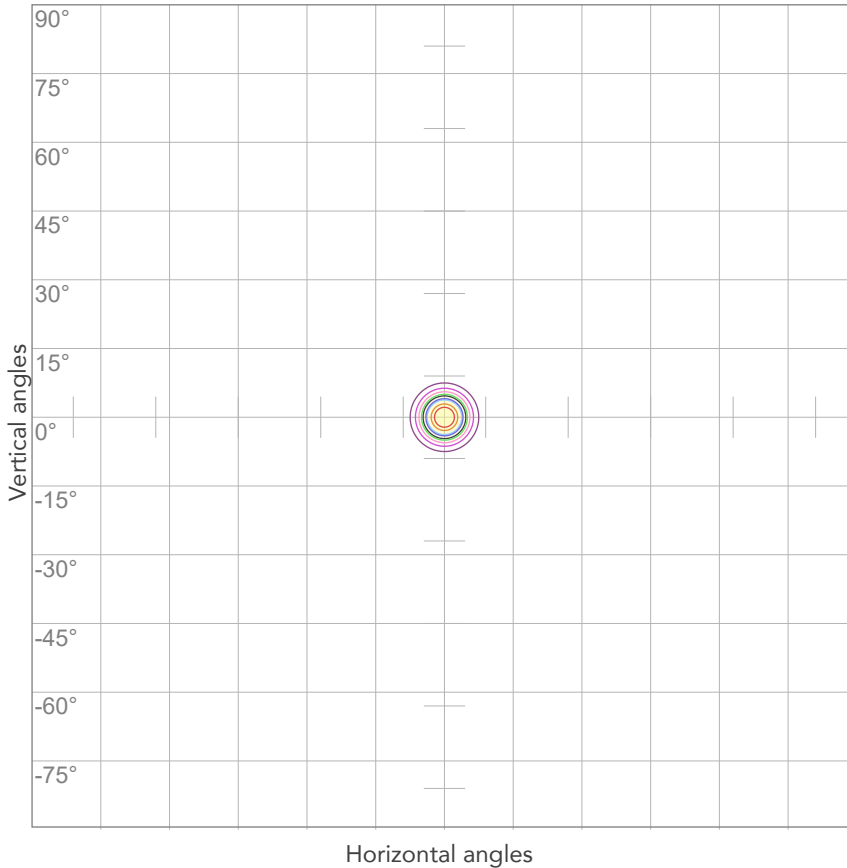

10%	5614 cd
20%	11229 cd
30%	16843 cd
40%	22457 cd
50%	28072 cd
60%	33686 cd
70%	39300 cd
80%	44915 cd

Conditions:

Number of c-planes: 2

Candela at center: 56143 cd

## ISO LUX DIAGRAM

MH: 10,0 m

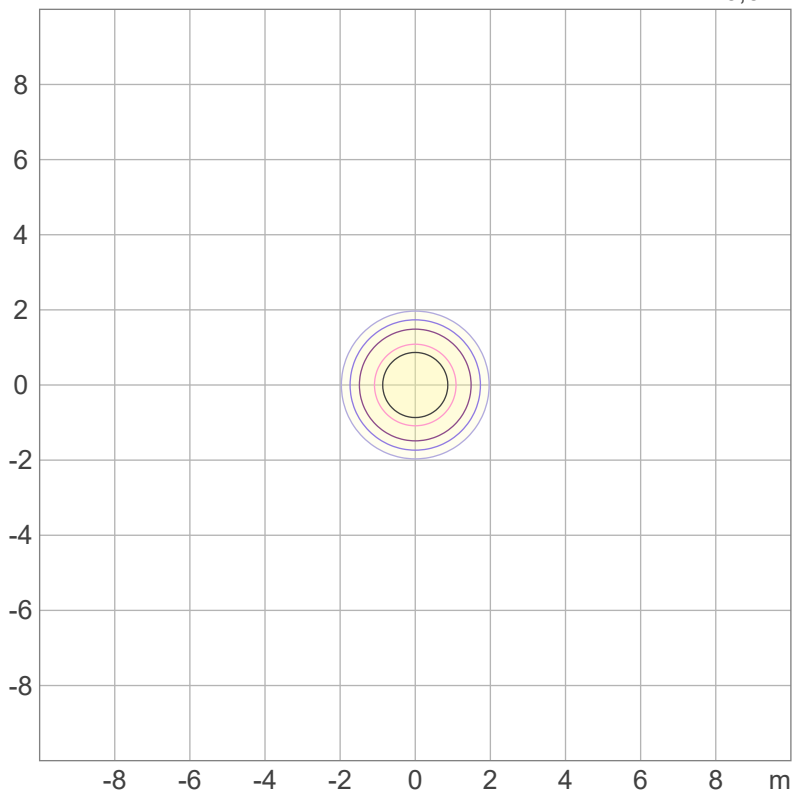

Mounting height: 10 meters (33 feet)

3%	16,8 lx
5%	28,1 lx
10%	56,1 lx
30%	168 lx
50%	281 lx

Conditions:

Number of c-planes: 2

Lux at center: 561 lx

*Lux distribution on a surface when lamp is mounted at 10 meters from the surface.*