

ROBE

Robin Arianne 6™

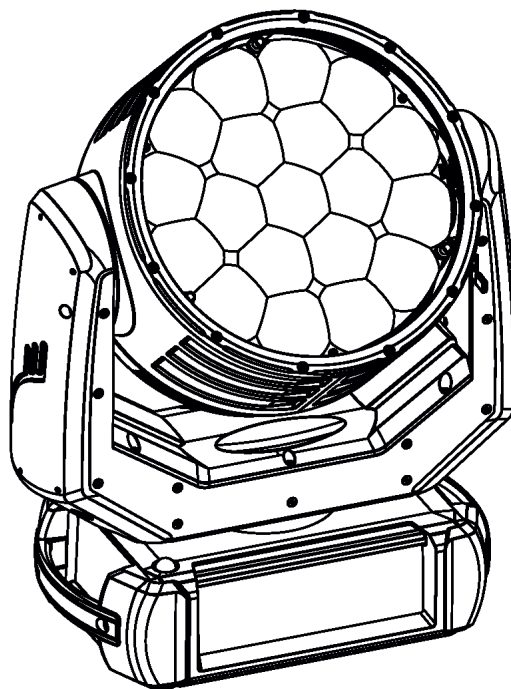

ROBE
Innovative
Technology

QR code for user manual



USER MANUAL

ROBE® lighting s.r.o. • Czech Republic • www.robe.cz

Version 1.0

Robin Arianne 6

Table of contents

1. Safety instructions	3
2. Operating determination	4
3. Fixture exterior view	6
4. Installation	7
4.1 Connection to the mains	7
4.2 Rigging the fixture	8
4.3 DMX-512 connection.....	11
4.4 Ethernet connection	12
4.5 Wireless DMX operation	14
5. Checking the IP65 integrity of the fixture	15
6. Operating the fixture at ambient temperatures below 0°C	17
7. Standby mode	18
8. Remotely controllable functions	19
9. Control menu map	21
10. Control menu	25
10.1 Tab "Address"	28
10.2 Tab "Information"	29
10.3 Tab "Personality"	31
10.4 Tab "Manual Control"	33
10.5 Tab "Stand-alone"	33
10.6 Tab "Service"	34
11. Software update	36
12. RDM	37
13. NFC	38
14. Error and information messages	39
15. Cleaning	40
16. Maintenance	42
16.1 Torques for watertight covers	44
16.2 Torques of Pan/Tilt motors screws	47
16.3 Checking and replacing the silica gel desiccants	48
17. Robe Ethernet Access Portal (REAP)	55
18. Technical Specifications	63
19. ChangeLog	66

**FOR YOUR OWN SAFETY, PLEASE READ THIS USER MANUAL CAREFULLY
BEFORE YOU INITIAL START - UP**

This device has left our premises in absolutely perfect condition. In order to maintain this condition and to ensure a safe operation, it is absolutely necessary for the user to follow the safety instructions and warnings in this manual.

The manufacturer will not accept liability for any resulting damages caused by the non-observance of this manual or any unauthorized modification to the device.

Please consider that damages caused by manual modifications to the device are not subject to warranty.

The Robin Arianne 6 was designed for outdoor use and it is intended for professional application only. It is not for household use.

1. Safety instructions

CAUTION!

Disconnect the fixture from mains before removing any cover of the fixture. With a high voltage you can suffer a dangerous electric shock when touching alive wires and electrical parts under covers!

Make sure that the available voltage is not higher than stated on the rear panel of the fixture. This fixture should be operated only from the type of power source indicated on the marking label. If you are not sure of the type of power supplied, consult your authorized distributor or local power company.

Always disconnect the fixture from AC power before cleaning or servicing any part of the fixture.

The power plug has to be accessible after installing the fixture. Do not overload wall outlets and extension cords as this can result in fire or electric shock.

Do not allow anything to rest on the power cord. Do not locate this fixture where the cord may be damaged by persons walking on it.

Make sure that the power cord is never crimped or damaged by sharp edges. Check the fixture and the power cord from time to time.

Refer servicing to qualified service personnel.

This fixture falls under protection class I. Therefore this fixture has to be connected to a mains socket outlet with a protective earthing connection.

Do not connect this fixture to a dimmer pack.

During the initial start-up some smoke or smell may arise. This is a normal process and does not necessarily mean that the device is defective.

The housing of the fixture becomes hot during its operation.

For replacement use fuse and battery of same type and rating only.

***LED light emission. Risk of eye injury.
Do not look straight at the fixture's LED source during operation. The intense light beam may damage your eyes. Sensitive persons may suffer an epileptic shock.
Provide advance notice that strobe lighting is in use.***

CAUTION! Risk group 2, RG-2



***Do not view the light output with optical instruments or any device that may concentrate the beam.
The light source contains blue LEDs.***

2. Operating determination

WARNING! This unit does not contain an ON/OFF switch. Always disconnect the power input cable from mains to completely remove power from unit when not in use or before cleaning or servicing the unit.

Avoid brute force when installing or operating the device.

Never lift the fixture by holding it at the fixture head as the mechanics may be damaged. Always hold the fixture at the transport handles.

When choosing the installation spot, please make sure that the device is not exposed to extreme heat or dust.

Make sure that the area below the installation place is blocked when rigging, derigging or servicing the fixture.

Always secure the fixture with an appropriate safety wire.

Only operate the fixture after having checked that the housing is firmly closed and all screws are tightly fastened.

Do not block the front cover glass with any object when the fixture is under operation.

The fixture becomes very hot during operation. Allow the fixture to cool approximately 30 minutes prior to manipulate with it.

To avoid damage of an internal optical system of the fixture, never let the sunlight (or other light source) lights directly to the lens array, even when the fixture is not working

Operate the device only after having familiarized with its functions. Do not permit operation by persons not qualified for operating the device.

The fixture housing never must be covered with cloth or other materials during its operation. Do not block fans or fans ventilation slots with any object. Fans and ventilation slots must remain clean.

Please consider that unauthorized modifications on the device are forbidden due to safety reasons!

Potential foggy front lens array does not influence function of the fixture and does not subject to complaint.

Please use only an original ROBE packaging (paper box, loader case or foam shell) for transporting the device, otherwise potential damage of the device during its transport will not subject to warranty.

***The fixture must not come into contact with sea water (salt water).
Damages or corrosion issues resulting from salt water will void
the manufactures warranty and will not be subject to any warranty
claims or repairs.***

The product (covers and cables) must not be exposed to a high frequency electromagnetic field higher than 3V/m.

Immunity of the equipment is designed according to the standard EN 55035 Electromagnetic compatibility of multimedia equipment - Immunity requirements.

The installation company should check levels of possible interferences above levels given by this standard (e.g. transmitters in surrounding area) before installing the equipment.

Emission of the equipment complies with the standard EN55032 Electromagnetic compatibility of multimedia equipment – Emission Requirements according to class A.

Emission of the equipment complies with the standard EN55032 Electromagnetic compatibility of multimedia equipment – Emission Requirements according to class A.

Contains FCC ID: 2A6PL-DMXRDMRW001

Contains IC: 29573-DMXRDMRW001

This device complies with part 15 of the FCC Rules. Operation is subject to the following two conditions: (1) This device may not cause harmful interference, and (2) this device must accept any interference received, including interference that may cause undesired operation.

Changes or modifications not expressly approved by the party responsible for compliance could void the user's authority to operate the equipment.

The [Device] wireless operation is safe and complies to RF Exposure requirements

This equipment has been tested and found to comply with the limits for a Class A digital device, pursuant to part 15 of the FCC Rules. These limits are designed to provide reasonable protection against harmful interference in a residential installation. This equipment generates, uses and can radiate radio frequency energy and, if not installed and used in accordance with the instructions, may cause harmful interference to radio communications. However, there is no guarantee that interference will not occur in a particular installation. If this equipment does cause harmful interference to radio or television reception, which can be determined by turning the equipment off and on, the user is encouraged to try to correct the interference by one or more of the following measures:

- Reorient or relocate the receiving antenna.
- Increase the separation between the equipment and receiver.
- Connect the equipment into an outlet on a circuit different from that to which the receiver is connected.
- Consult the dealer or an experienced radio/TV technician for help.

3. Fixture exterior view

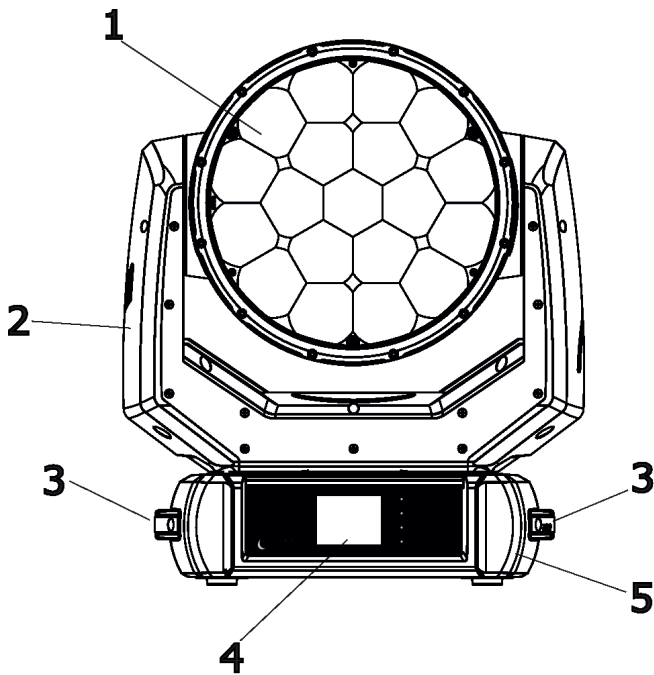

- 1 - Lens array
- 2 - Yoke
- 3 - Handles
- 4 - Control panel
- 5 - Base
- 6 - Ethernet OUT
- 7 - Ethernet IN
- 8 - Power
- 9 - Cover of fuse and battery holders
- 10 - DMX IN
- 11 - DMX OUT
- 12- Tilt lock

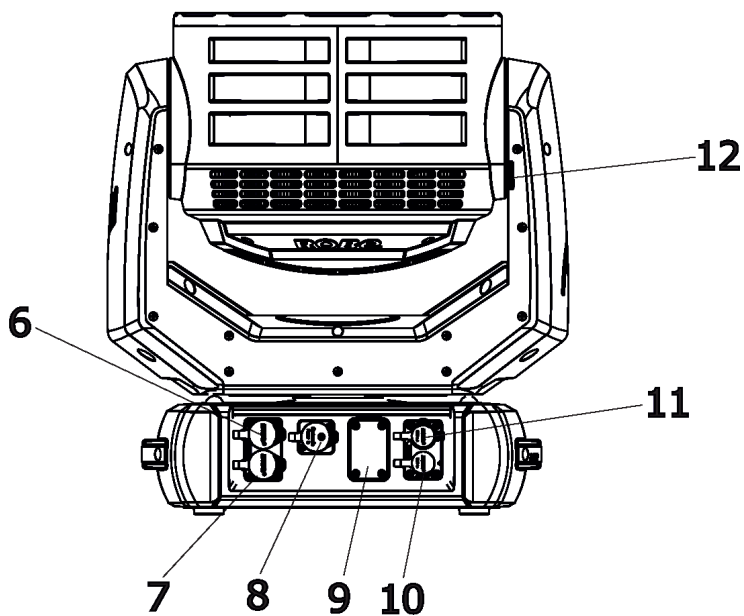

The head has to be locked for transportation - the tilt lock latch (12) has to be in the locked position. To unlock the head, move the latch to unlock position before operating the fixture.

The ENTER/DISPLAY ON button also serves for switching the display on (for a while) when the fixture is disconnected from the mains.

4. Installation



Fixtures must be installed by a qualified electrician in accordance with all national and local electrical and construction codes and regulations.

The Robin Arianne 6's panel connectors are dust and water protected according to IP 65 by mating with related cable connectors. They cannot stay disconnected outdoor.

All unused panel connectors have to be sealed by the rubber caps.

Visually check panel connectors on accidental water leaks before connecting related cable connectors.

If some water will appear in panel connectors, do not connect cable connectors, especially power!

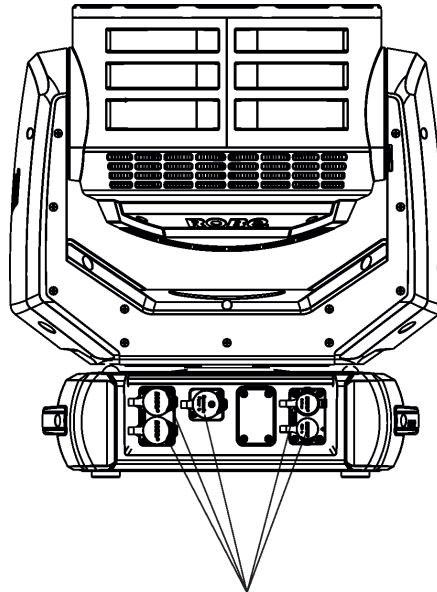

The rubber caps have to be placed on unused connectors.

4.1 Connection to the mains

**For protection from electric shock, the fixture must be earthed!
The fixture has to be connected to an electric outlet which is equipped with a residual-current device (residual-current circuit breaker)!**

Wiring and connection work must be carried out by a qualified electrician.

The Robin Arianne 6 is equipped with auto-switching power supply that automatically adjusts to any 50-60Hz AC power source from 100-240 Volts.

Mains cable powerCON TRUE1 In/open ended is enclosed to the fixture. We recommend to install cord end-sleeves 1.5 x 8 (cross section in mm² x length in mm) on the cords of the mains cable. If you need to install a power plug on the mains cable to allow connection to power outlets, install a grounding-type (earthed) plug, following the plug manufacturer's instructions. If you have any doubts about proper installation, consult a qualified electrician. Connection to mains has to keep IP 65 protection rating.

Core (EU)	Core (US)	Connection	Plug Terminal Marking
Brown	Black	Live	L
Light blue	White	Neutral	N
Yellow/Green	Green	Earth	

This device falls under class one and must be earthed (grounded)!

Ensure all connections and the power plug on the cable are properly sealed.

To apply power, first check that the head pan and tilt locks are released.

4.2 Rigging the fixture

A structure intended for installation of the fixture (s) must safely hold weight of the fixture(s) placed on it. The structure has to be certificated to the purpose.

The fixture (fixtures) must be installed in accordance with national and local electrical and construction codes and regulations.

For overhead installation, the fixture must be always secured with a safety wire.

When rigging, derigging or servicing the fixture staying in the area below the installation place, on bridges, under high working places and other endangered areas is forbidden.

Allow the fixture to cool for ten minutes before handling.

Fixture should be installed in areas outside walking paths, seating areas, or away from areas where unauthorized personnel might reach the fixture by hand.

IMPORTANT! OVERHEAD RIGGING REQUIRES EXTENSIVE EXPERIENCE, including calculating working load limits, installation material being used, and periodic safety inspection of all installation material and the projector. If you lack these qualifications, do not attempt the installation yourself, but use a help of professional companies.

CAUTION: Fixtures may cause severe injuries when crashing down! If you have doubts concerning the safety of a possible installation, do not install the fixture!

The fixture has to be installed out of the reach of public.

The fixture must never be fixed swinging freely on the truss.

Danger of fire !
When installing the device, make sure there is no highly inflammable material (decoration articles, etc.) in a distance of min. 0.5 m.

CAUTION!
Use 2 appropriate clamps to rig the fixture on the truss.
Follow the instructions mentioned at the bottom of the base.
Make sure that the device is fixed properly! Ensure that the structure (truss) to which you are attaching the fixtures is secure.

For securing the fixture to the truss, install a safety wire which can hold at least 10 times the weight of the fixture.

Truss installation

1. Bolt Clamps (4) to the Omega adaptors (1) with M12 bolts and lock nuts through the hole in the Omega adaptors.
2. Fasten the Omega adaptors on the bottom of the base by means of the quick-lock fasteners (2) and tighten them fully clockwise.
3. Install the fixture on the truss.
4. Pull a safety wire (3) through the carrying handle (7) and the truss (6) as shown on the picture below in a suitable position so that the maximum fall of the fixture will be 20 cm. Fasten a snap hook in the attachment point (5).

Use only the safety wire with a snap hooks with screw lock gates.

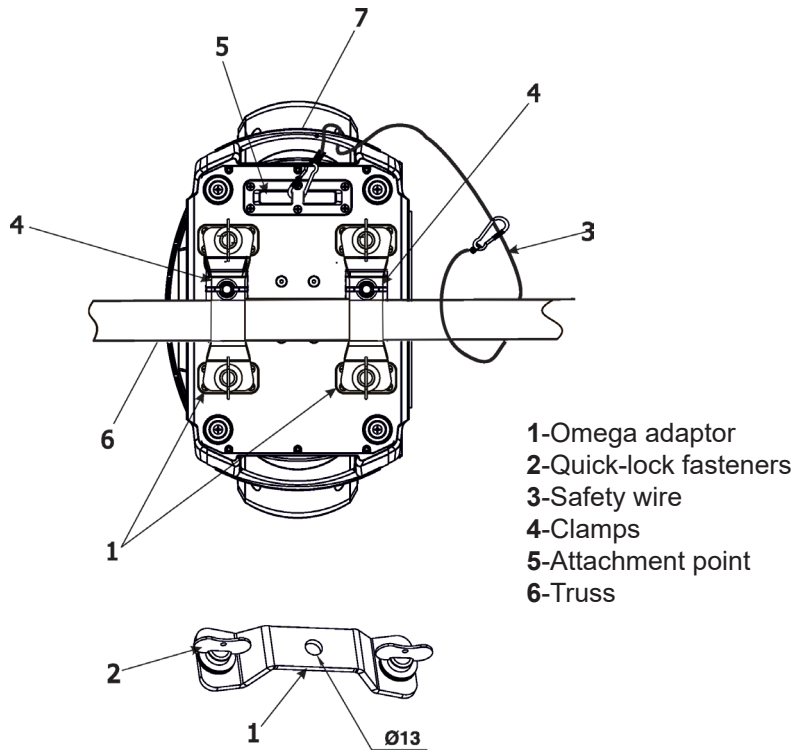

Available positions of Omega holders

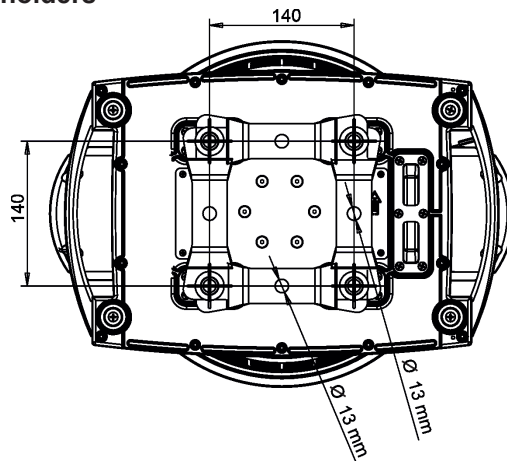

Note:

Surface corrosion of the Omega adaptors may occur, especially if this fixture has been used outdoors. Surface corrosion will not affect the safety of the Omega adaptors. Omega adaptors corrosion is not covered by the warranty.

Allowed installation positions of the Arianne 6

*Caution for side mounting!
 Panel connectors must face to the ground.*

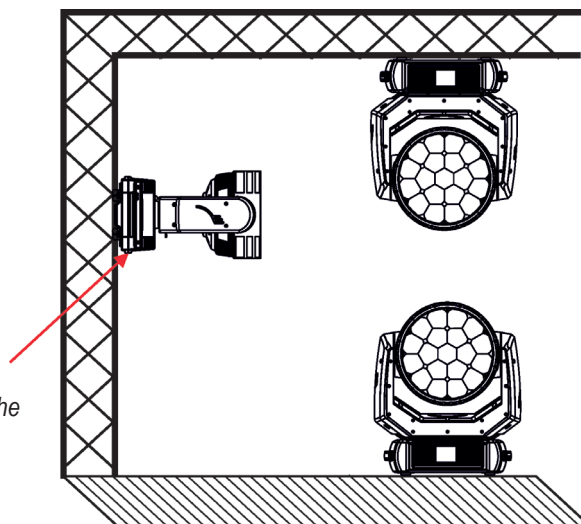

Note for open-air installation: if the fixture stands on the ground, min. distance of 4" (10cm) between the fixture base and the ground has to be kept.

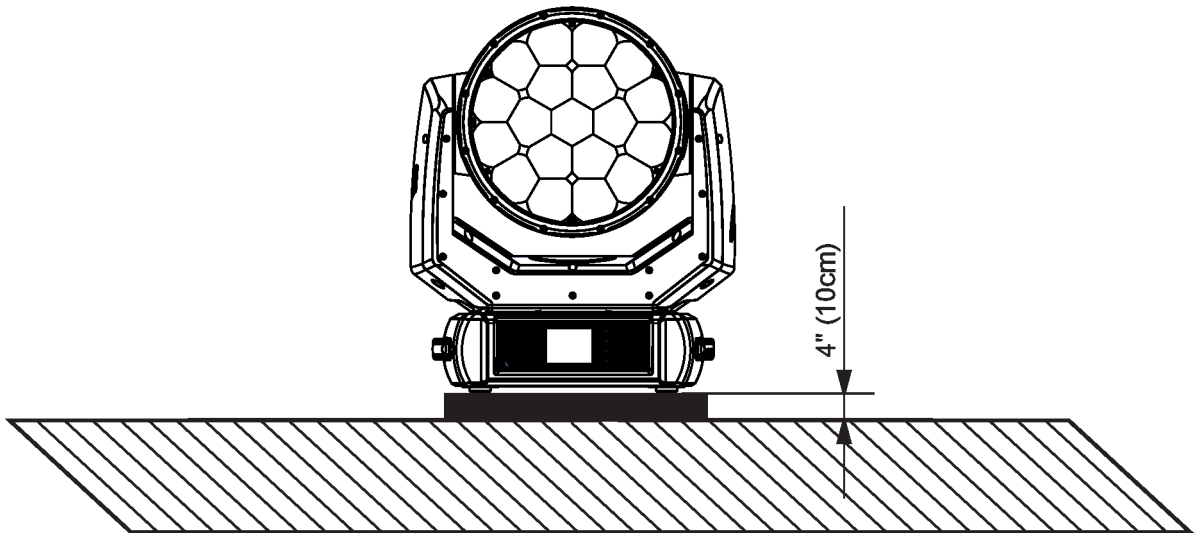

***When installing fixtures side-by-side,
avoid illuminating one fixture with another!***

***DANGER TO LIFE!
Before taking into operation for the first time, the installation has to be approved by
an expert!***

***In order to protect the internal parts of the head from the sun, the function
PARKING POSITION must be switched ON before switching the fixture off.***

The PARKING POSITION function is located on the Power/Special functions channel (120-129 DMX). If the function is on, the fixture will automatically detect via G-sensor whether the fixture is on the floor or hangs on the truss or is mounted sideways on the truss and moves the pan and tilt to the position (including movement of zoom to the front part of the head) in which the head will always face down. Owing this position of the fixture head, there is not chance to burn internal parts of the head by the sun light.

4.3 DMX-512 connection

The fixture is equipped with 5-pin XLR sockets for DMX input and output.

Only use a shielded twisted-pair cable designed for RS-485 and 5-pin XLR plugs and connectors in order to connect the controller with the fixture or one fixture with another.

To keep declared IP rating of the XLR panel connectors, all used XLR connectors and cables have to meet IP 65 rating.

DMX output

XLR socket (female)



- 1 - Shield
- 2 - Signal (-)
- 3 - Signal (+)
- 4 - Not connected
- 5 - Not connected

DMX input

XLR socket (male)

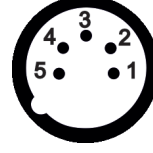

- 1 - Shield
- 2 - Signal (-)
- 3 - Signal (+)
- 4 - Not connected
- 5 - Not connected

Building a serial DMX chain:

Connect the DMX output of the first fixture in the DMX chain with the DMX input of the next fixture. Always connect one output with the input of the next fixture until all fixtures are connected. Up to 32 fixtures can be connected.

Caution: At the last fixture, the DMX cable has to be terminated with a terminator. Solder a 120 Ω resistor between Signal (-) and Signal (+) into 5-pin XLR plug and plug it into DMX output of the last fixture.

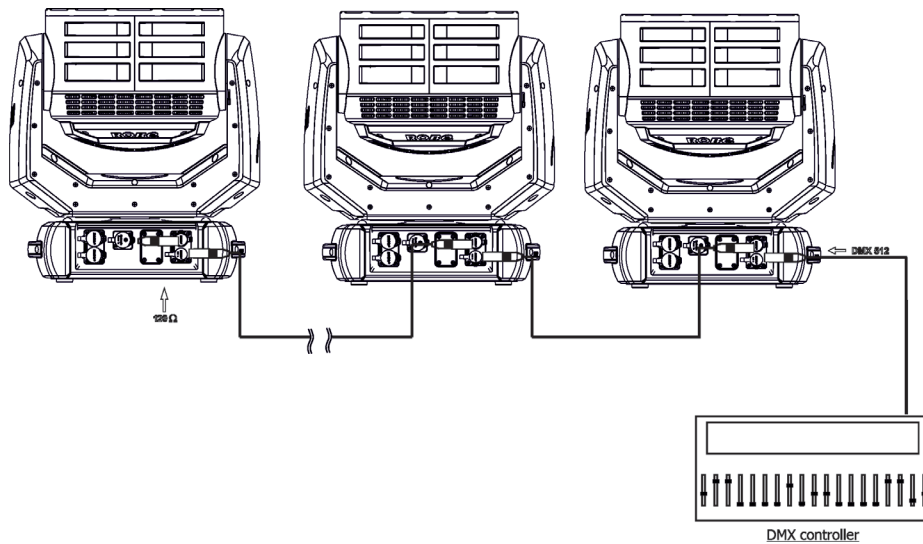

The Robin Arianne 6's panel connectors are dust and water protected according to IP 65 by mating with related cable connectors. They cannot stay disconnected outdoor. All unused panel connectors have to be sealed by the rubber caps.

4.4 Ethernet connection

To keep declared IP rating of the fixture, all used RJ45 and XLR connectors and cables have to meet IP 65 rating.

The fixtures on a data link are connected to the Ethernet with appropriate communication protocol (e.g. ArtNet). The control software running on your PC (or light console) has to support Art-Net protocol.

Art-Net communication protocol is a 10 Base T Ethernet protocol based on the TCP/IP. Its purpose is to allow transfer of large amounts of DMX 512 data over a wide area using standard network technology.

IP address is the Internet protocol address. The IP uniquely identifies any node (fixture) on a network.

The Universe is a single DMX 512 frame of 512 channels.

The Robin Arianne 6 is equipped with two 8-pin RJ-45 socket for Ethernet input. Use a network cable category 5 (with four “twisted” wire pairs) and standard RJ-45 plugs in order to connect the fixture to the network.

RJ-45 socket (front view):

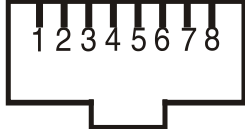

- | | |
|------------------|------------------|
| 1- TD+ | 5- Not connected |
| 2- TD- | 6- RX- |
| 3- RX+ | 7- Not connected |
| 4- Not connected | 8- Not connected |

RJ-45 plug (front view):

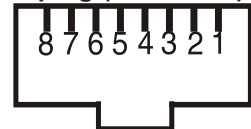

Patch cables that connect fixtures to the hubs or LAN sockets are wired 1:1, that is, pins with the same numbers are connected together:



If only the fixture and the computer are to be interconnected, no hubs or other active components are needed. A cross-cable has to be used:



If the fixture is connected with active Ethernet socket (e.g. switch) the network icon  will appear at the bottom right corner of the screen:

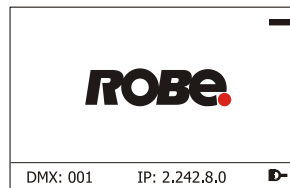

Ethernet operation

Connect the fixtures to the Ethernet network.

Option “Artnet (gMa1, gMa2 or sACN)” has to be selected from “Ethernet Mode” menu on the fixture.

Set IP address (002.xxx.xxx.xxx / 010.xxx.xxx.xxx) and the Universe.

(DMX address=76)

IP address=002.168.002.004
Universe=1

(DMX address=51)

IP address=002.168.002.003
Universe=1

(DMX address=26)

IP address=002.168.002.002
Universe=1

(DMX address=1)

IP address=002.168.002.001
Universe=1

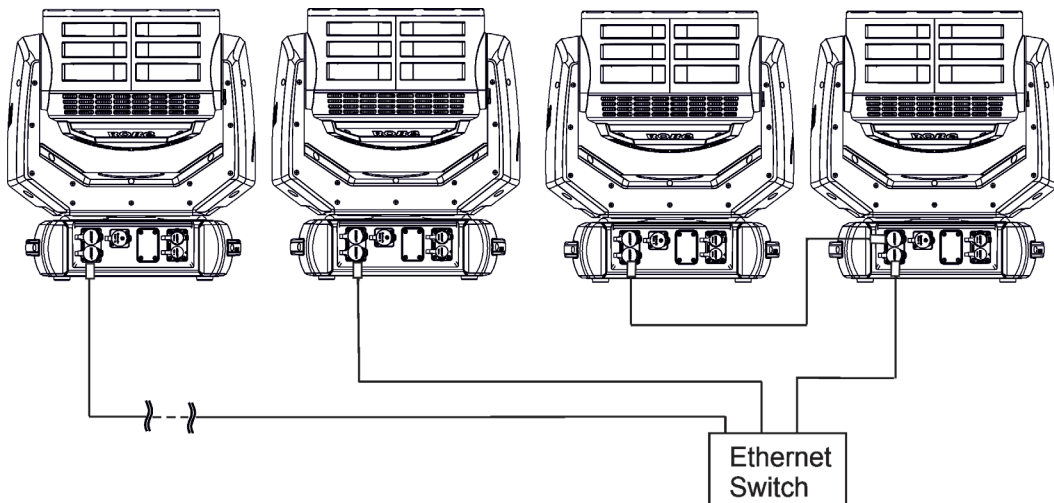

An advised PC setting: IP address: 002.xxx.xxx.xxx / 010.xxx.xxx.xxx (Different from fixture IP addresses)
NET mask: 255.0.0.0

The Arianne 6 is equipped with Ethernet Pass Through Switch which sustains Ethernet integrity, when the fixture has no power, it automatically maintains network connectivity.

If you use the Ethernet IN-OUT way for the Ethernet connection, max. 8 fixtures can be connected in the IN-OUT line

Ethernet / DMX operation

Option "Artnet" (gMal or gMA2 or sACN) has to be selected from "Ethernet Mode" menu at first fixture.

Option "Ethernet To DMX" has to be selected from the menu "Ethernet Mode" at the first fixture (connected to the Ethernet) in the fixture chain, next fixtures have standard DMX setting.

Connect the Ethernet-input of the first fixture in the data chain with the network. Connect the DMX output of this fixture with the input of the next fixture until all fixtures are connected to the DMX chain.

Caution: At the last fixture, the DMX chain has to be terminated with a terminator. Solder a 120 Ω resistor between Signal (-) and Signal (+) into a XLR-plug and connect it in the DMX-output of the last fixture.

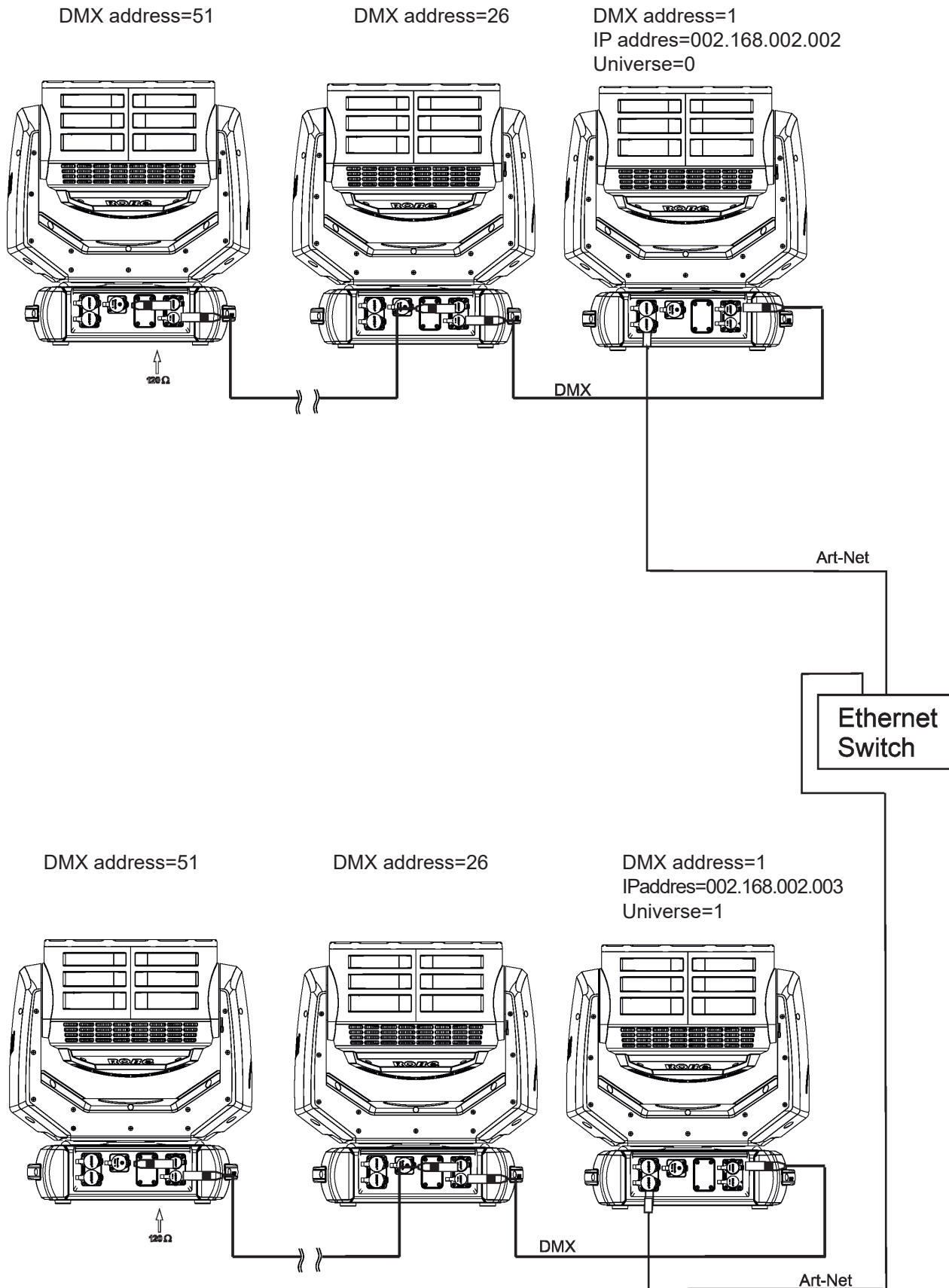

4.5 Wireless DMX operation

The integrated wireless DMX/RDM module allows receiving wireless DMX. The ROBE wireless DMX/RDM module has full support for wireless communication protocols at entertainment market. Modul is based on well known LumenRadio RF technology, with implemented wire interface for connection with Robe products. RF output for MCX interface antenna as standard output

The item " Wireless " from the menu "DMX Input" allows you to activate receiving of wireless DMX (Personality--> DMX Input -->Wireless.). First two options from the "DMX Input" menu are stated in DMX chart as well (channel Power/Special functions , range of 10-19 DMX). If DMX input option is changed by DMX command, the change is permanently written into fixture's memory.

DMX range of 10-19 switching fixture to the wired/wireless operation is active only during first 10 seconds after switching the fixture on.

After switching the fixture on, the fixture checks both modes of receiving DMX in the following order:

1. For the first five seconds, the fixture receives DMX signal from the wired input. If the Power/Special functions channel is set at some DMX input option, the fixture will receive DMX value according to this option. If DMX input option is set to the wired input , this option is saved and checking procedure is finished. If DMX input option is not set, the fixture continues next 5 seconds in scanning wireless DMX signal-see point 2.
2. For the next 5 seconds the fixture receives wireless DMX signal and again detects if the Power/Special functions channel is set at some DMX input option, if not, the fixture will take option which is set in the fixture menu "DMX Input".

To link the fixture with DMX transmitter.

The fixture can be only linked with the transmitter by running the link procedure at DMX transmitter . After linking , the level of DMX signal (0-100 %) is displayed in the menu item "Wireless State" (Information -->Wireless State).

To unlink the fixture from DMX transmitter.

The fixture can be unlinked from receiver via the menu item " Unlink Wireless Adapter" (Information--> Wireless State --> Unlink Wireless Adapter).

Note: If the option "Wireless In/XLR Out" is selected (Personality--> DMX Input -->Wireless In/XLR Out), the fixture receives wireless DMX and sends the signal to its wired DMX output. The fixture behaves as " Wireless/Wired" adaptor.

Example:

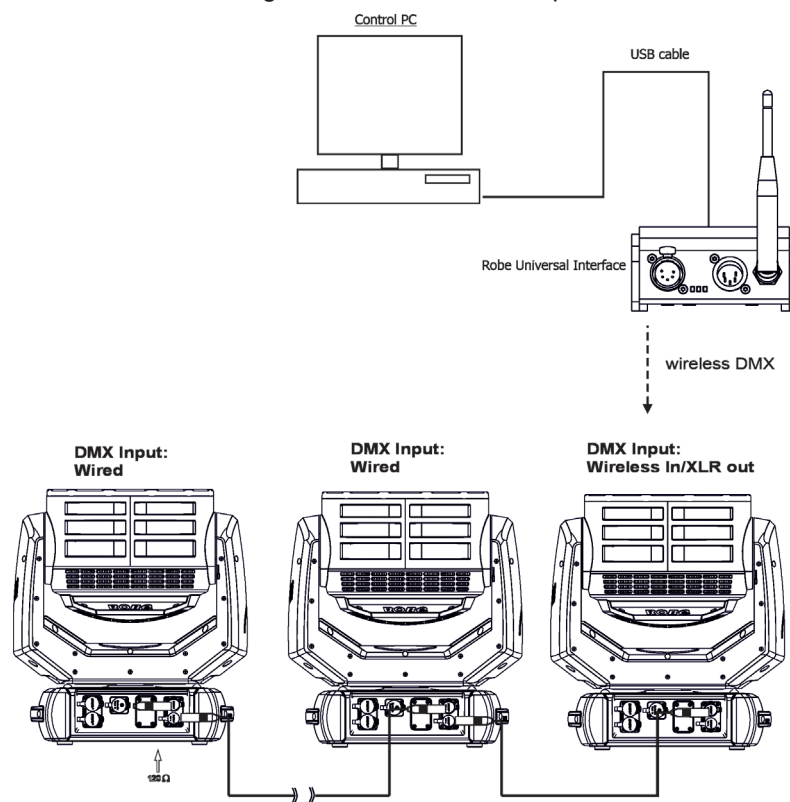

5. Checking the IP65 integrity of the fixture.

The Robin Arianne 6 is IP65 rated lighting fixture which has been designed to be protected against the ingress of dust and pressure water jets from any direction.

1. Smart pressure test - for this test serves the function "Pressure Test" in the tab Service. Unique testing procedure allows you easy testing of the IP65 integrity of the fixture. You do not need any external device connected to the fixture for running the test.

The fixture has to be connected to mains (must not be in Standby mode) and a head temperature (at pressure sensor) cannot be higher than 55°C. The pressure test takes about 8 minutes and can be run at earliest 10 minutes after closing light output of the fixture. The pressure test can be repeated at earliest 2 minutes after last pressure test.

The function "Pressure Test" should be run after the following actions:

- **unscrewing/screwing back any watertight cover**
- **replacing desiccants in the fixture head and base (boxes with silica gel)**
- **replacing desiccants in the fixture arm (tubes with silica gel)**
- **replacing pan or tilt motor**

The pressure test can be also run by DMX command (channel Power/Special function) or from web interface REAP (Robe Ethernet Access Portal). During the pressure test fixture does not respond to DMX commands (except DMX values 92-93 on the channel Power/Special functions).

Examples of screens (front panel display) of the smart pressure test:

Fixture waits for 10 minutes period elapsing (inside of the fixture is too hot)

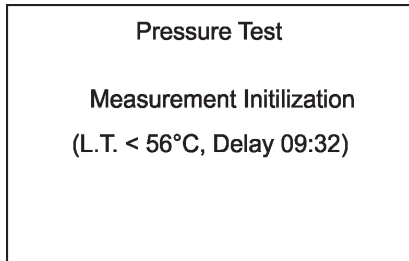

Fixture waits for 2 minutes period elapsing (pressure test was repeated too early)

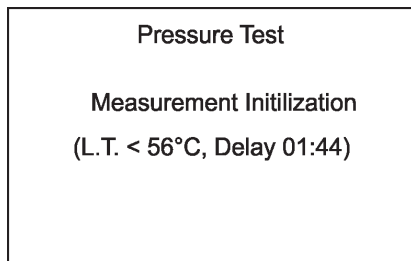

Setting fans

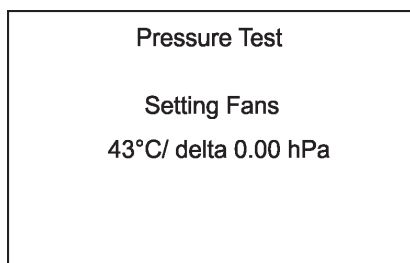

Test in progress

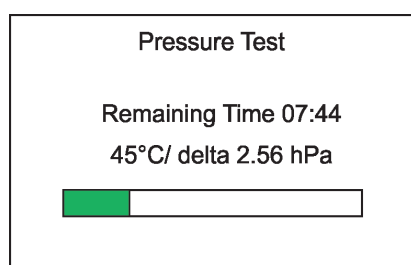

Legend:

07:44Remaining Time (minutes) to finish of pressure test.
45°C.....Temperature at pressure sensor.
delta 2.56 hPa...Pressure difference.
The pressure difference has to be >7 hPa for successful test.

Test passed

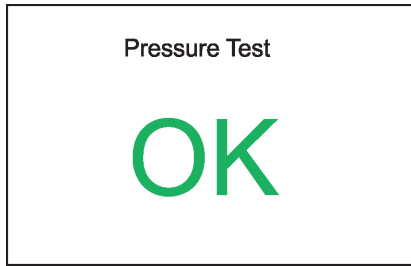

Test failed

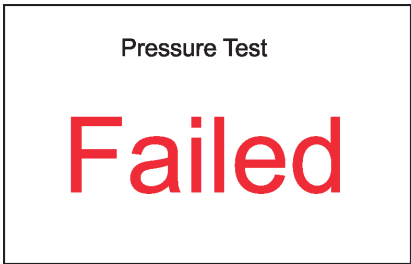

If the first pressure test failed and the second is OK, the fixture complies with IP65 integrity. If the pressure test twice fails despite checking of correct tightening of the cover screws and gaskets under covers, the fixture has to be tested by means of "Enhanced pressure test". For this type of pressure test is needed the Pressure IP Testing Set ROBE (P/N 10980659). Please ask your ROBE distributor for help.

The message "Valve Seal Error" means that valve or coil in the valve is defective or there is a connection problem.

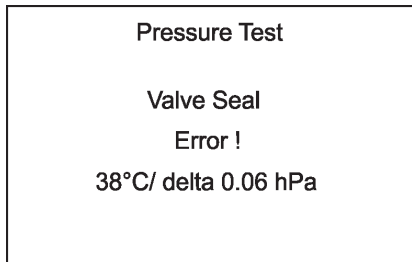

Check the connection between the valve and head, especially cable connector. Other reason can be faulty coil in the valve or faulty valve.



Cable connector

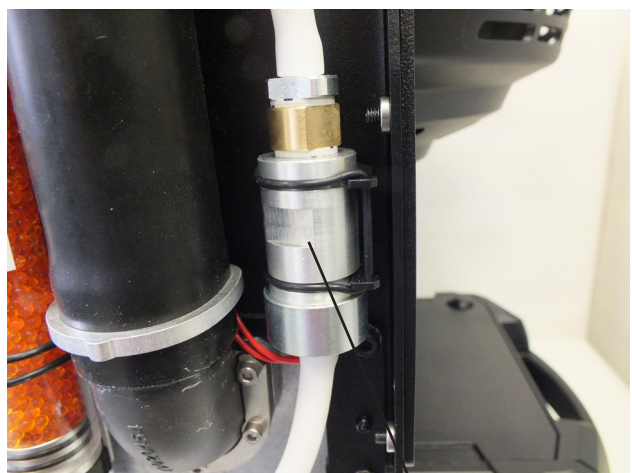

Valve

The message "Not Available At The Moment" means that the fixture is not connected to mains.

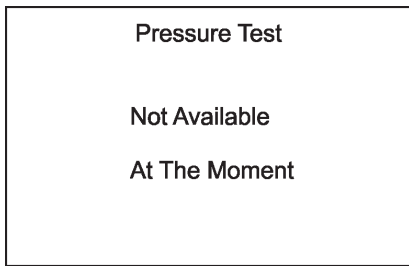

2. Enhanced pressure test - a special equipment Pressure IP Testing Set ROBE (P/N 10980659) is intended for this kind of pressure test. Only trained technician should handle the equipment.

Pressure IP Testing Set ROBE
in case:

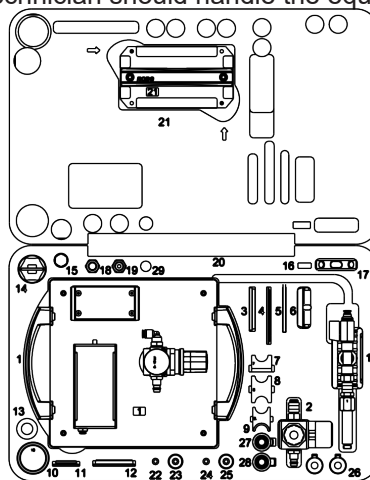

If this equipment is used for pressure test of the fixture, the following values of pressure have to be kept:

Underpressure test.

300 mbar for 1 minute, pressure fall can be to 10 mbar maximally.

Overpressure test

150 mbar maximally!

6. Operating the fixture at ambient temperatures below 0°C

Design of the Arianne 6 allows its operation at ambient temperature up to -50°C, but you have to take some specific into account before operating the fixture.

1. Fixture is not in Standby mode.

Ambient temperatures from 0°C to -10°C.

The fixture can be switched off but after powered it on, fixture reset can be delayed in range of 0 - 30 minutes depending on ambient temperature (max. delay is at low ambient temperature). This delay is caused by heating fixture effects on operating temperature. The fixture does not respond to DMX during heating the fixture on operating temperature.

We recommend to switch the fixture on at least 30 minutes before show.

Ambient temperatures from -11°C to -50°C.

The fixture should be permanently powered on in order to keep operating temperature of fixture's effects. If the fixture is switched off, reset of the fixture will last long time (up to 1 hour depending on ambient temperature) until fixture effects reach their operating temperature. The fixture does not respond to DMX during heating the fixture on operating temperature.

2. Fixture is in Standby mode.

If the fixture is switched to Standby mode (fixture has to be connected to mains), the fixture keeps internal temperature on a level suitable for operation of fixture's effects without delay, heating up of the fixture inside is done automatically.

7. Standby mode

The fixture can be switched to Standby mode by means of web interface REAP or DMX command (channel Power/Special functions, DMX values 6-7).

Standby mode can be cancelled by means of web interface REAP, DMX command (channel Power/Special functions, DMX values 8-9) or by switching the fixture off and on.

Standby mode helps conserve power when a fixture is not in use, without fully powering it off. The max. power consumption of the fixture in Standby mode does not exceed 20 W (if the fixture is heated, power consumption is higher). Standby mode is indicated by a notice on the fixture display.

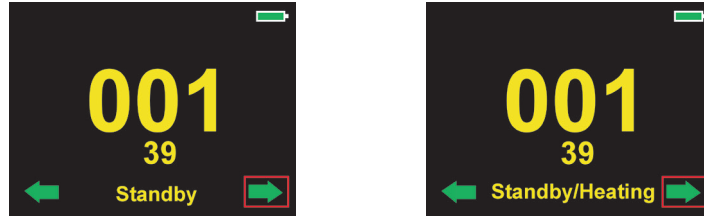

In the Standby mode, the fixture display is functional and can be used for setting of the fixture, but all motors and fans are deactivated, light output is closed.

As the fixture motors are deactivated, the fixture does not respond to DMX values controlling effects but the channel Power /Special functions can be used for fixture settings.

The fixture in Standby mode provides information for RDM and REAP and also can be set its behaviour by means of the RDM and REAP.

Main benefits of Standby mode:

- there is not time delay of fixture reset at ambient temperatures below 0°C.
- By means of REAP user has current information about fixture (settings, temperatures, state of desiccant in the fixture head).

8. Remotely controllable functions

Virtual colour wheel

This wheel contains 66 preset colours, rainbow effect in both directions is available.

Colour temperature correction (CTC)

This channel allows to set calibrated white colour from range of 8000K-2700K.

RGBL or CMY colour mixing system

The RGBL colour mixing system is based on red, green, blue and lime high power LEDs. Option for switching the fixture to the CMY colour mixing system is available.

Colour Mix control

The Colour Mix control (channel 35/19) defines relation between colour channels (RGBL,CMY, CTO, Virtual colour wheel).

"Virtual" = Virtual color wheel

"Colour mix"Pixel = Colour channels (RGBL/CMY/CTC)

DMX value	Function
0-9	Virtual colours ("Virtual" has priority)
10-19	Maximum mode (highest values have priority)
20-29	Minimum mode (lowest values have priority)
30-39	Multiply mode (multiply Virtual and Colour Mix)
40-49	Addition mode (Virtual + Colour Mix) - default
50-59	Subtraction mode (Virtual - Colour Mix)
60-69	Inverted Subtraction mode (Virtual - Colour Mix)
70-128	Reserved
129	Virtual colours ("Virtual" has priority)
130-254	Crossfade (crossfade between Virtual and Colour mix)
255	Colour channels ("Colour mix" has priority)

Zoom

Motorized zoom offers beam range of 43.8 to 60°.

Zone control

The Arianne 6 allows you to control three LED zones independently.

Zone order:

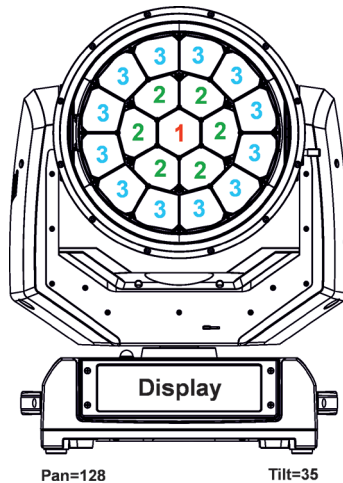

Dimmer/Shutter unit

Smooth 0 - 100 % dimming is provided by the electronic control unit. This unit is also used for strobe effects with variable speed.

Pan/Tilt

Precise pan/tilt movement due to built-in electronic motion stabilizer. The electronic motion stabilizer ensures precise position of the fixture's head during its movement and reduces its swinging when the truss shakes. Pan movement range: 540°, tilt movement range: 228°.

Pan/tilt positions

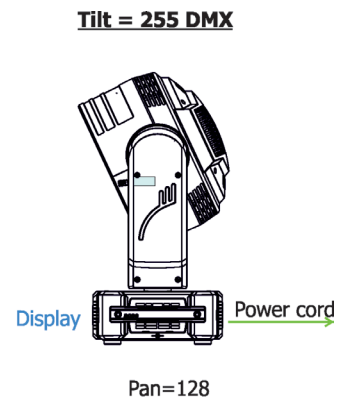
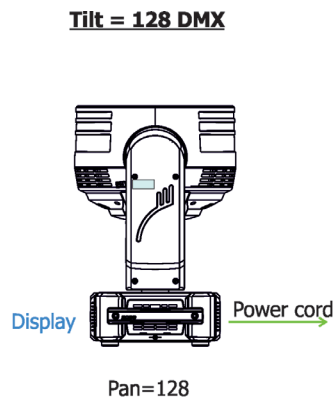
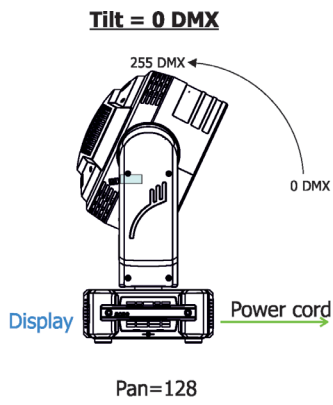



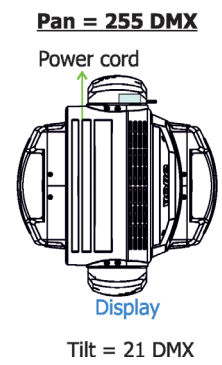
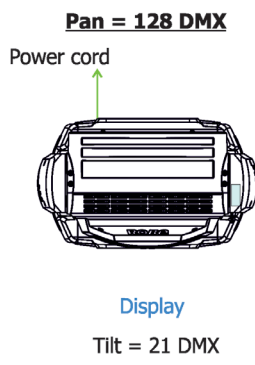
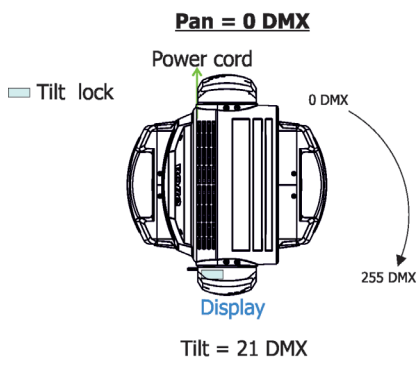

Tilt movement range: 220° Pan movement range: 540°



9. Control menu map

Default settings=**Bold print**

Tab	Level 1	Level 2	Level 3	Level 4	Level 5	Level 6	
Addressing	Settings	DMX Address	001-512				
		DMX Preset	Mode 1 , Mode 2, Mode 3, Mode 4				
		Ethernet Settings	Ethernet Mode	Disable			
				ArtNet			
				gMA1			
				gMA2			
				sACN			
				Ethernet To DMX	Off , On		
				IP Address/Net Mask	Default IP Address		
					Custom IP Address		
					Net Mask		
				ArtNet Universe	0-255		
				MANet settings	MANet/II Universe	01-256	
					MANet Session ID	01-32	
				sACN Settings	sACN Universe	00001-32000	
					sACN Priority	0-255	
				sACN Merging	Off , On		
	Information	Fixture Times	Power On Time	Total Hours			
				Resetable Hours			
	Fixture Temperatures	Base Temperature	Current				
			Maximum NonRes.				
			Maximum Res.				
		Driver Temp.	Current				
			Maximum NonRes.				
			Maximum Res.				
		RAINS Status					
		Sensor s Info					
		DMX Values	Pan				
			:				
			Dimmer Fine				
		Wireless State	Signal Quality				
			Unlink Wireless Adapter				
		Power Channel State					
		Software Versions	Display System				
			Module M				
			Module L1				
			Module L2				
			Module L3				
			Module O				
		Module DL					
		Module GR					
	SW HW Version	Display System					
		Module M					
		Module L1					
		Module L2					
		Module L3					
		Module O					
		Module DL					

Tab	Level 1	Level 2	Level 3	Level 4	Level 5	Level 6
		Module GR				
	Product IDs	Mac Address				
		RDM UID				
		RDM Label				
	View Logs	Fixture Errors				
		Fixture States	Power On			
			Power Off			
		Fixture Position				
		Fixture Temperatures	Base Temperatures			
		Sensors Logs				
		Pressure Tests Logs				
		System Logs				
Personality						
	DMX Presets	Mode 1				
		:				
		Mode 4				
		View Selected Preset				
	DMX Input	Wired Input				
		Wireless Input				
		Wireless In/XLR Out				
	Pan/Tilt Settings	Pan Reverse	Off, On			
		Tilt Reverse	Off, On			
		Pan/Tilt Feedback	Off, On			
		Pan/Tilt mode	Time			
			Speed			
	Pan/Tilt EMS	On, Off				
	Blackout Settings	Blackout During M.C.	Off, On			
		Blackout while:	Pan/Tilt moving	Off, On		
	Colour Mixing Mode	RGBL				
		CMY				
	White Point 8000K	Off, On				
	Tungsten Eff. Sim.	Off				
		750W				
		1000W				
		1200W				
		2000W				
		2500W				
	Dimmer Curve	Linear				
		Square Law				
	LEDs Output Frequency	300 Hz				
		600 Hz				
		1200 Hz				
		2400 Hz				
		High				
	LEDs Frequency Adjust	-1266....0....+126				
	Init Effect Positions	Pan	0-255			
			:			
			0-255			
	Reset Init Effect Pos.					
	Screen Settings	Display Intensity	1-10			

Tab	Level 1	Level 2	Level 3	Level 4	Level 5	Level 6
		Screen Saver Delay	Off-10min.			
		Touchscreen Lock	Off-10min.			
		Recalibrate Touchscreen				
		Display Orientation	Normal			
			Inverted			
			Auto			
	Temperature Unit	°C, °F				
	Fan Settings	Fan Mode	Auto			
			High			
			Quiet			
		Fan Noise Level				
		Quiet-Blackout Fan Off	Off			
	Date & Time Settings					
	Default Settings					
	Memory Tools	SD card	SD State			
			Mount SD			
			Unmount SD			
			Format SD			
	Password Protection					
	Reset Web Password					
Manual Control	Reset Functions	Total System reset				
		Pan/Tilt reset				
		Zoom Reset				
	Manual Effect Control	Pan	0-255			
		:				
		Dimmer Fine	0-255			
Stand -Alone	Test Sequences	Dynamic Mode				
		Static Mode	Pan	0-255		
			Tilt	0-255		
			Zoom	0-255		
	Preset Playback	None				
		Test				
		Prog. 1				
		Prog. 2				
		Prog. 3				
	Play Program	Play Program 1				
		Play Program 2				
		Play Program 3				
	Edit Program	Edit Program 1	Start Step	1-100		
			End Step	1-100		
			Edit Program Steps	Step 1	Pan	0-255
				:	:	
				:	Dimmer Fine	0-255
				:	Step Time	0-25,5 sec.
				Step 100	Pan	0-255
					:	
					Dimmer Fine	0-255
					Step Time	0-25,5 sec.

Tab	Level 1	Level 2	Level 3	Level 4	Level 5	Level 6
Service	Pressure Test					
	Adjust DMX Values	Pan	0-255			
		:				
		Dimmer Fine	0-255			
	Calibrations	Calibrate Effects	Pan	0-255		
			Tilt:	0-255		
			Zoom	0-255		
		Calibrate colours				
		Calibrate Pan/Tilt EMS				
		Load Default Calibrations				

10. Control menu

The Robin Arianne 6 is equipped with the QVGA screen with battery backup and four control buttons which allow you to set the fixture's behaviour according to your needs, obtain information on its operation, test its various parts and program it, if it has to be used in a stand-alone mode. The fixture supports NFC (Near-Field Communication).

NFC interface and control buttons on the front panel

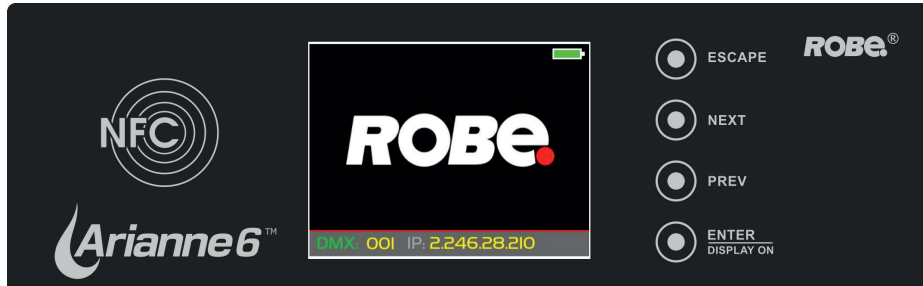











[ESCAPE] button used to leave the menu without saving changes.

[NEXT] , [PREV] buttons for moving between menu items and symbols, adjusting values.

[ENTER/Display On] button used to enter the selected menu (menu item) and to confirm adjusted value.

If the fixture is disconnected from mains, the button switches the screen on.

Icons used in the screen menu:

-  - [back arrow] used to move back to the previous screen (menu).
-  - [up arrow] used to move up on the previous page.
-  - [down arrow] used to move down on the next page.
-  - [confirm] used to save adjusted values, to leave menu or to perform desired action.
-  - [cancel] used to leave menu item without saving changes.
-  - [confirm+copy] used to save adjusted values and copy them to the next prog. step.
-  - [warning icon] used to indicate some error which has occurred in the fixture.
-  - [Ethernet] used to indicate Ethernet connected.
-  - [display turn] used to turn the display by 180°.
-  - [slider control] used to recall slider system for setting desired value.
-  - [keyboard control] used to recall keyboard system for setting desired value.

The menu page displays icons for each function that you can perform from the screen.

After switching the fixture on, the screen shows the screen with the ROBE logo:



Note: The green icon at the top right corner of the screen indicates the level of the display battery charging. If the whole icon is green, the battery is fully charged while the red icon indicates exhausted battery. The battery

charges during fixture operation, its charging lasts cca 6 hours.

We recommend that the fixture should be in operation at least 7 hours per week to keep the battery fully charged. If you switch the fixture on and this screen will not appear till 1 minute, switch the fixture off and on again. If the screen lights, the battery is exhausted. In case the screen still does not light, the battery is faulty.

This is also indicated by an error message "Faulty battery" and if such an error message appears the battery should be replaced immediately. The lifetime of the battery is highly dependent on ambient temperature (and consequently on base temperature). If the maximum ambient temperatures (as recorded and displayed in menu: Information -> Fixture Temperatures -> Ambient Temperature -> Maximum NonRes.) are kept within the specified limits, the battery should last for at least two years. Should the ambient temperatures exceed the specified maximum temperature, the lifetime of the batteries could be considerably shortened even up to just one year or less and also result in physical damage (battery leakage) or unreliable fixture functions.

Damage caused by batteries failed due to exceeded maximum ambient temperature cannot be claimed under warranty terms.

Press the [ENTER/Display On] button to enter the "Address" menu.

Any item may be selected from a screen by pressing the [NEXT] or [PREV] buttons to scroll through list items. With each press, the next item is highlighted. Press [ENTER/Display On] to select the highlighted item.

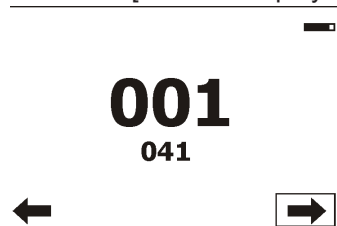

Before first fixture operation, set current date and time in the menu "Date &Time Settings" (menu path: Personality--> Date &Time Settings).

As the fixture can be operated at wide range of ambient temperatures, suitable environment has to be maintained in inside of the fixture. The following messages under DMX address inform you about fixture status.



The fixture is waiting for finishing all reset procedures. Fixture does not respond to DMX.

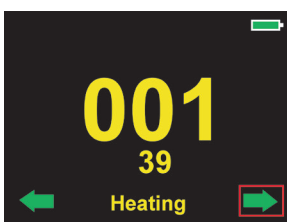

The fixture is waiting for reaching operating temperature of the fixture inside (inside temperature is below 0°C). Fixture does not respond to DMX.

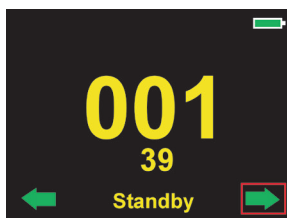

The fixture is in standby mode. Fixture effects does not respond to DMX, but display is active. Fixture sends its statuses and recorded physical values (temperature, humidity, pressure) to the REAP.

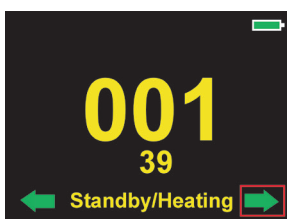

The fixture is in standby mode and inside of the fixture is heated (ambient temperature is below 0°C). Fixture does not respond to DMX, but display is active. Fixture sends its statuses and recorded physical values (temperature, humidity, pressure) to the REAP.

Locking/unlocking the screen

To lock the screen, display the screen with **ROBE** logo, touch the [ESCAPE] button and slide your finger across buttons: [ESCAPE] --> [NEXT] --> [PREV]--> [ENTER/Display On] and back: [ENTER/Display On] --> [PREV] --> [NEXT]--> [ESCAPE].

The sign "Buttons are locked" will appear on the screen. If this sign will not appear, repeat finger sliding again with a different speed.

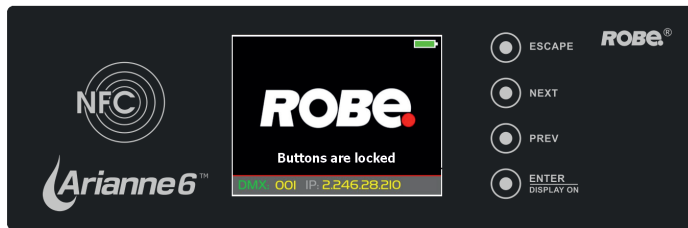

To unlock the screen, touch the [ESCAPE] button and slide your finger across buttons: [ESCAPE] --> [NEXT] --> [PREV]--> [ENTER/Display On] and back: [ENTER/Display On] --> [PREV] --> [NEXT]--> [ESCAPE].

The sign "Buttons are locked" will disappear from the screen. If this sign still remains on the screen, repeat finger sliding again with a different speed.

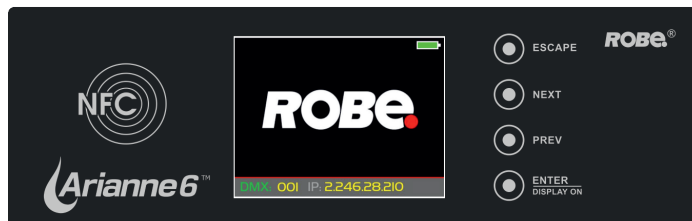
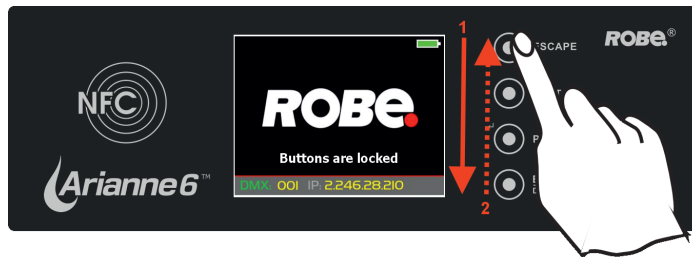

10.1 Tab " Address"



DMX Address - Select the menu to set the DMX start address.

Blinking DMX address means that the fixture is either not receiving DMX data or that the set DMX address is higher than allowed, exceeding the DMX footprint of the set DMX mode.

DMX Preset - Use the menu to select desired channel mode.

View Selected Preset - Use the menu to display channels included in the selected mode.

Ethernet Settings - The menu allows all needed settings for the Ethernet operation

Ethernet Mode

Disable - The option disables Ethernet operation.

Artnet - Fixture receives Artnet protocol

gMA1 - Fixture receives MANet 1 protocol

gMA2 - Fixture receives MANet 2 protocol

sACN - Fixture receives sACN protocol

Ethernet To DMX - Fixture receives protocol from the Ethernet input and sends DMX data to its DMX output (fixture works as an "Ethernet/DMX converter", next fixture can be connected to its DMX output and you can build a standard DMX chain by connecting another fixtures. Only one fixture has to be connected to the Ethernet.

IP Address/Net Mask - Select this menu to set IP address. IP address is the Internet protocol address. The IP uniquely identifies any node (fixture) on a network.

There cannot be 2 fixtures with the same IP address on the network!

Default IP Address -Preset IP address, you can set up only first byte of IP address (2 or 10) e.g. **002.019.052.086**.

Custom IP Address - The option enables to set up all bytes of IP address.

Net Mask - The option enables to set up all bytes of Net Mask.

ArtNet Universe - Use this item to set a Universe (0-255). The Universe is a single DMX 512 frame of 512 channels.

MANet Settings - Use this menu to set parameters for MANet operation.

MANet Universe I/II - The value of this item can be set in range 1-256.

MANet Session ID - The value of this item can be set in range 1-32.

sACN Settings - Use this menu to set parameters for sACN operation.

sACN Universe - The value of this item can be set in range 1-32000.

sACN Priority - The value of this item can be set in range 0-255.

This device implements a receiver for **Streaming ACN (sACN) as defined in ANSI E1.31** and is capable of receiving DMX512-A data transported over IP networks.

When multiple sources transmit data for the same universe, arbitration is performed according to the following rules:

1. **Source Priority** – The receiver selects the stream with the highest sACN universe priority value.
2. **Equal Priority Sources** – When multiple sources transmit with the same priority, the receiver performs HTP (Highest Takes Precedence) merging on a per-slot basis, where the highest DMX slot value from the active sources is utilized.
3. **Universe Selection** – The universe number processed by the receiver is user-configurable.

The device does not implement per-address priority extensions and relies on **universe-level priority and HTP merging** for multi-source arbitration.

All received data is interpreted as **DMX512-A slot values according to ANSI E1.11**, transported via the sACN protocol.

10.2 Tab "Information"



Fixture Times - The menu provides readouts of fixture operation hours and air filters using hours.

Power On Time - Select this menu to read the number of fixture operation hours.

Total Hours - The item shows the total number of the operation hours since the Robin Arianne 6 has been fabricated.

Resettable Hours - The item shows the number of the operation hours that the Robin Arianne 6 has been powered on since the counter was last reset.

In order to reset this counter to 0, touch the text box next to the item "Resettable Hours."

Fixture Temperatures - The menu is used to view temperatures of the fixture's inside.

Driver Temperatures - The menu shows temperature on the LEDs PCB in the fixture head.

Current - A current temperature of the LEDs PCB.

Maximum NonRes. - A maximum temperature of the LEDs PCB since the fixture has been fabricated.

Maximum Res. - A maximum temperature of the LEDs PCB since the counter was last reset.

In order to reset some counter to 0, touch desired text box next to the item "Maximum Res."

Base Temperature - The menu shows temperature in the fixture base.

Current - A current temperature in the fixture base.

Maximum NonRes. - A maximum temperature in the fixture base since the fixture has been fabricated.

Maximum Res. - A maximum temperature in the fixture base since the counter was last reset.

In order to reset this counter to 0, touch the text box next to the item "Maximum Res."

RAINS Status - The menu item gives you information about environment in the fixture.

RAINS (Robe Automatic Ingress Neutralization System) manages humidity, temperature and pressure control using an active monitoring system to automatically remove any moisture detected within the fixture and provides permanent monitoring to ensure peak performance of the fixture.

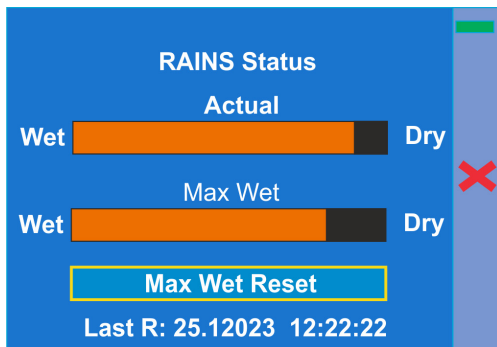

Silica gel desiccant in tube in the fixture head

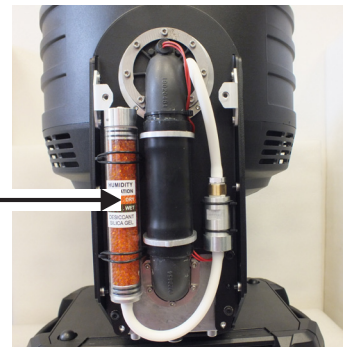

The bar chart **Actual** informs you about current humidity in the fixture. The bar chart changes depending on humidity, temperature and pressure in the fixture. The bar chart depends on current conditions in the fixture and can be different at start of fixture operation, after 10 minutes of its operating, after closing fixture dimmer etc.

The bar chart **MAX WET** informs you about maximum humidity achieved in the fixture since the chart was last reset. The bar chart also informs you about saturation of silica gel with water in tube in the fixture head and is deciding indicator for its checking and replacement.

The option **MAX WET reset** resets the bar chart MAX WET. Date and time of last reset is displayed below the option.

Examples of RAINS statuses:

Dry desiccant in tube in the fixture arm

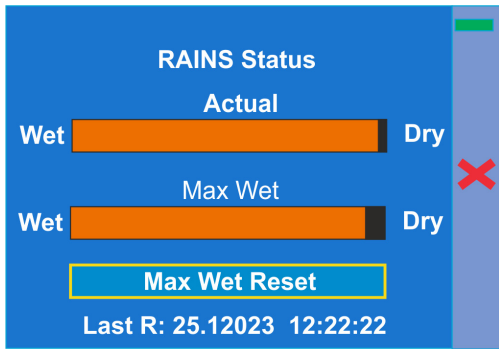

Desiccant in tube in the fixture arm partially saturated with water

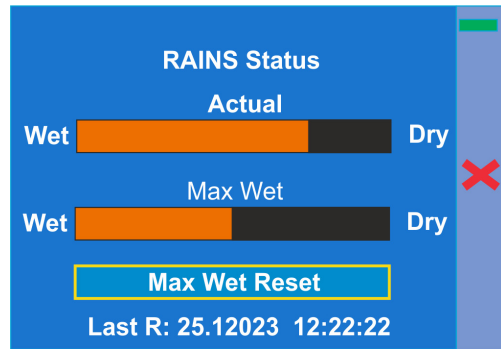

Desiccant in tube in the fixture arm fully saturated with water

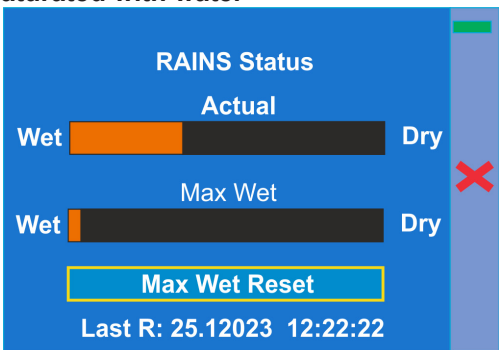

Desiccants in tube in the fixture arm is saturated with water and should be replaced.

After replacing it, reset the item MAX WET.

It is not necessary to replace silica gels desiccants in plastic boxes in the fixture head (at lens array) and base. These desiccants should be checked (and replaced if it is needed) at removing head or base covers, e.g. at some service intervention.

Sensors Info - The menu items shows you current conditions in the fixture head (at pressure sensor): temperature, relative humidity and pressure.

DMX Values - The menu is used to read DMX values of each channel received by the fixture.

Wireless State - The menu serves for reading of the wireless operation status.

Unlink Wireless Adapter - The item serves for unlinking the fixture from DMX transmitter.

Power Channel State - The menu item shows state of the Power/Special functions switches.

Software Version - Select this item to read the software version of the fixture modules:

Display System - A display processor on the display board in the fixture base

Module M - a pan/Tilt processors in the fixture arm

Module L1 - LEDs control processor 1

Module L2 - LEDs control processor 2

Module L3 - LEDs control processor 3

Module O - a zoom control processor

Module DR - a LEDs driver control processor

Module DL - a Data Logger control module

Wireless - a wireless DMX module (if installed)

SW HW Version - Select this item to read hardware versions of PCBs and their software versions.

Display System - A display processor on the display board in the fixture base

Module M - a pan/Tilt processors in the fixture arm

Module L1 - LEDs control processor 1

Module L2 - LEDs control processor 2

Module L3 - LEDs control processor 3

Module O - a zoom control processor

- Module DR** - a LEDs driver control processor
- Module DL** - a Data Logger control module
- Wireless** - a wireless DMX module (if installed)

Product IDs - The menu is used to read the MAC Address ,RDM UID and RDM Label.

View Logs - Use this menu to read fixture's data which have been recorded during fixture operation. This collected data allows easier troubleshooting.

Fixture Errors - Use this menu to read fixture errors which have occurred during fixture operation.

Fixture States - Recorded following actions: Fixture On, Fixture Off.

Fixture Position - Recorded installation positions of the fixture:

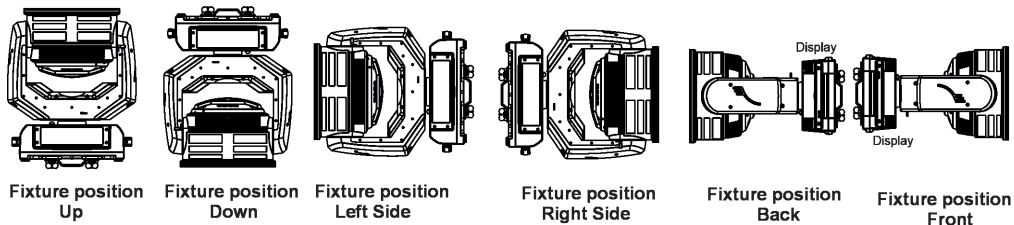

Fixture Temperatures - Recorded temperatures which have exceeded defined levels.

Sensor Logs - In the menu item are recorded physical values in the fixture: temperature, relative humidity and pressure.

Pressure Test Log - In the menu item are recorded values related to executed pressure tests: date and time, temperature, pressure difference, duration of pressure test and its result.

Note: The log buffer can contain 8000 records max. If the buffer is full, old data will be overwritten.

10.3 Tab "Personality"



DMX Preset - Use the menu to select desired channel mode.

View Selected Preset - Use the menu to display channels included in the selected mode.

DMX Input - Use the menu to select mode of DMX signal receiving.

Wired - DMX signal is received by means of the standard DMX cable.

Wireless - DMX signal is received by means of the inbuilt wireless module.

Wireless In/XLR Out - the fixture receives wireless DMX and sends the signal to its wired DMX output.

The fixture behaves as " Wireless/Wired" adapter.

The options "Wired" and "Wireless" are also stated in DMX chart (channel Power/Special functions).

Note. If the wireless module is not installed in the fixture, the following message will appear:

DMX Input Set to Wired
Wireless Module Missing

If the fixture is not connected to mains, the message "Not Available In Offline Mode" will appear after entering the menu DMX Input. To enter this menu, the fixture has to be connected to mains.

Pan/Tilt Settings - Use the menu set behaviour of both pan and tilt movements.

Pan Reverse - The item allows to invert pan movement.

Tilt Reverse - The item allows to invert tilt movement.

Pan/Tilt Feedback - The item allows to return the mowing head to the required pan/tilt position after changing the position by an external force if this option is set on.

Note. Be careful, the Pan/Tilt Feedback should be permanent On, the option Off is not suitable for standard operation and the head of the fixture can be damaged!

Pan/Tilt mode - Use this menu to set the mode of the pan/tilt movement

Time mode – The pan and tilt will move with different speeds and they will come at the same time to the end point of their tracks (pan and tilt use their optimal speeds).

Time of the pan/tilt movement (25.5 sec. max.) is set by the channel "Pan/Tilt speed, Pan/Tilt time".

Speed Mode - Both Pan and tilt will move with the same speed as adjusted at the channel "Pan/Tilt speed, Pan/Tilt time".

Pan/Tilt EMS - Built-in electronic motion stabilizer ensures precise position of the fixture's head during its movement and also reducing its swinging when the truss shakes.

Blackout Settings - Use the menu if you need to close the light output under certain conditions which are described below

Blackout DMC - Blackout during movement correction. Set this option On if you wish to close light output during the time when the head goes to its correct position, which has been changed by an external force.

Active Blackouts - Use this menu if you wish to close the light output during effect changes.

Pan/Tilt Moving - The menu item enables to close light output while the pan/tilt coordinates are changing.

White Point - If the function is on, the CTC channel allows to set desired white in range of 10 000K-1800K (0 DMX=10000K, 255 DMX=1800K). Necessary condition is , that RGBL channels have to be full or set at the same DMX values, e.g. 150.

If this function is off, the range of whites is not uniform and may be different for each fixture.

Colour Mixing Mode - This item allows switching into RGBL or CMY mode. In the CMY mode, the lime(8bit)/lime (16) bit channels are not active.

Tungsten Effect Sim. - This function simulates behaviour of a halogen lamp during dimming at calibrated whites 2700K, 3200K. You can select from various lamp wattage simulation: 750W, 1000W, 1200W, 2000W, 2500W.

Dimmer Curve - You can select desired dimmer curve: Linear or Square Law.

LEDs Output Frequency - The function allows you to set the PWM (Pulse Width Modulation) output frequency of LEDs to 300Hz, 600Hz, 1200Hz, 2400Hz or High.

LEDs Frequency Adjust - The menu item allows you fine adjustment of the LED frequency around selected frequency in the menu item "LEDs Output Frequency".

-1...-126 - Frequency levels 1 - 1266 under selected frequency.

00 - Selected frequency (in the menu "LEDs Output Frequency")

1...126 - Frequency levels 1 - 126 above selected frequency.

Init Effect Positions - Use the menu to set all effects to the desired positions at which they will stay after switching the fixture on without DMX signal connected.

Reset Init Effect Pos. - Use the menu to set all effects to the default (factory) positions.

Screen Settings - Use this menu to change the touch screen settings.

Display Intensity - The item allows to control the intensity of the screen (1-min., 10-max.).

Screen saver Delay - The item allows you to keep the screen on or to turn it off automatically after 1-10 minutes after last touch (or pressing any button on the control panel).

Touchscreen Lock - The item allows you to lock the screen after last touch (or pressing any button on the control panel). The time delay can be set in range of 1-10 minutes. To unlock the screen, press the [ENTER/Display On] button.

Recalibrate Touchscreen - The item starts calibration of the touchscreen. Follow the instructions on the screen.

Display Orientation - The menu allows to change display orientation.

Normal - Standard display orientation if the fixture is placed horizontally (e.g. on the ground).

Inverted - This function rotates menu 180 degrees from current orientation.

Auto - The option activates a gravitation sensor for automatic screen orientation.

Note: **Auto** option is set as default. You change the display orientation by touching the icon  on the display, an the option set in the "Display Orientation" menu is temporarily overridden.

Temperature unit - Use the menu item to change temperature unit from °C to °F.

Fan Settings - Use the menu to set fans operation mode.

Fan Mode - Use the menu to set the fixture fans to max. power mode (option "**High**") or to the auto-control mode (option "**Auto**"). The third option "**Quiet**" allows you to set desired fan noise. The light output of the fixture is reduced at low speeds of fans.

Quiet - Blackout Fan Off - The menu item allows you to stop all fans in the fixture (option "**On**") when its light output is closed (shutter in range of 0-31 DMX or dimmer in 0 DMX).

Date & Time Settings - Use this menu to set current date and time for the fixture log system (menu "View Logs"). Set this menu item before first fixture operation.

Default Settings - The menu item allows to set all fixture parameters to the default (factory) values.

Memory Tools - the menu item SD card allows you to allows you to do operations with SD card.

SD card - Internal SD card in the fixture base.

SD State - The menu item shows state of internal SD card!

Mount SD - The menu item allows you to mount internal SD card to the system.

Unmount SD - The menu item allows you to unmount internal SD card from the system.

Format SD - The menu item allows you format internal SD card. The card has to be mounted to the system before formatted it.

Password Protection - allows to enter password in order to prevent unauthorized person from changing setting of the fixture. Password is set to 7623 and cannot be changed.

Reset Web Password - The menu item allows you to reset a password for access to the REAP (default password: 2479, user: robe).

10.4 Tab "Manual Control"



Reset Functions - The menu allows to reset the fixture either per function modules or all modules together.

Total System Reset - The item resets all function modules.

Pan/Tilt Reset - The item resets the pan and tilt movement.

Zoom Reset - The item resets the zoom module.

Manual Effect control - Use the menu to control all fixture channels by means of the control panel.

10.5 Tab "Stand-alone"



Test Sequences -Use the menu to run a test/demo sequences without an external controller, which will show you some possibilities of using Robin Arianne 6.

Dynamic Mode - This mode uses all Robin Arianne 6 functions including pan/tilt movement and therefore is good for a complete introduction of the fixture.

Static Mode - This mode is suitable for projections on the wall, ceiling or ground without any pan/tilt movement. Adjust the pan, tilt and zoom to desired positions and start test sequences by touching the green ► icon.

Preset Playback - This menu allows you to select the program which will be played in a loop after switching the fixture on (the option is commonly used in a stand-alone operation without an external controller).

None - The option disables "Presetting playback" function.

Test - The option starts the test sequences.

Prog. 1 - The option starts user program number 1.

Prog. 2 - The option starts user program number 2.

Prog. 3 - The option starts user program number 3.

Play program - Use the menu to run desired user program in a loop.

Play Program 1 - The option starts user program number 1.

Play Program 2 - The option starts user program number 2.

Play Program 3 - The option starts user program number 3.

Edit Program - Use the menu to create or to edit desired program. The Robin Arianne 6 offers 3 free programs, each up to 100 steps.

Edit Program 1 - The option allows to edit user program number.1.

Edit Program 2 - The option allows to edit user program number 2.

Edit Program 3 - The option allows to edit user program number 3

To edit program:

1. Select the item which you want to edit ("Edit Program 1" - "Edit Program 3").
 2. By means of the items "Start Step" and "End Step" set first and last step of the program
 3. Select the item "Edit Program Steps".
 4. Select the item "Step 1".
 5. From the list of effects select desired effect and set its value. Browse through the list by pressing the [up arrow] and [down arrow] and set all desired effects.
An item "Step Time" (value of 0-25.5 sec.) is the time during which effects last in the current step
 6. Save adjusted effects to the current step by the item ✓ .
- If you stay on the item ✓ and simultaneously hold the ENTER button, the current program step will be copied to the next program step.
6. Repeat the steps 5 and 6 for next program steps.
 7. After editing desired program steps, adjust the length of the program by means of the items "Start Step" and "End Step".

Note.

If you have made some changes in the program steps and you are leaving the programming menu, the following notice will appear: " Program Was Modified"
" Press OK For Save"

✗ - leaves program menu without saving values

10.6 Tab "Service"



Pressure Test - The menu item runs a procedure which checks the IP65 integrity of the fixture. The fixture has to be connected to mains and the head temperature (at pressure sensor) cannot be higher than 55°C. The pressure test lasts about 8 minutes and can be run at earliest 10 minutes after closing light output (shutter closed) of the fixture. The pressure test can be repeated at earliest 2 minutes after last pressure test.

For more details of pressure test please see the chapter Checking the IP65 integrity of the fixture.

Adjust DMX Values - The menu allows you to set all effects to desired positions before fine calibration of the effects .

Calibrations - This menu enables fine calibration of fixture effects and download default calibration values.

Calibrate Effects - The menu allows the fine adjustment of effects.

Pan- a pan position fine adjustment

Tilt - a tilt position fine adjustment

Zoom - a zoom position fine adjustment

Calibration of the effects via the control board

1. Disconnect DMX controller from the fixture and enter the "Calibrate Effects" menu.
2. Use the [up arrow] and [down arrow] to find "Pan" and touch it to enter the fine effect adjustment screen.
3. Set desired value and save it by touching the [confirm].
4. Repeat steps 2 and 3 for next item

5. After calibrating all effects, touch the [confirm] to save all adjusted values and reset the fixture.

Calibrate Colours - The menu serves for adjusting of LEDs saturation in factory to achieve uniform white colours

Calibration protocol:

<i>Effect</i>	<i>Mode 1</i>	<i>Mode 2</i>	<i>Mode 3</i>	<i>Mode 4</i>
Pan-fine adjustment	channel 16	channel 28	channel 44	channel 51
Tilt - fine adjustment	channel 17	channel 29	channel 45	channel 52
Zoom- fine adjustment	channel 18	channel 30	channel 46	channel 53

Calibrate Pan/Tilt EMS - This menu item allows calibration of the pan/tilt electronic motion stabilizer. Important: during this calibration any external force must not influence the fixture and the surface at which the fixture stands (or truss if the fixture hangs) has to be without movement, shake, strokes etc.

Load Default Calibrations - The item loads default (factory) calibration values.

11. Software update

For software update of the fixture serves Robe Toolkit. The Robe Toolkit is a universal tool for Robe fixtures which includes Device Updater, Library Manager, Device Manager and simple DMX controller.

Please see the Toolkit user manual for more details about fixture update.

Software update of the Arianne 6 cannot be done by means of standard Robe Uploader software.

For more information please see <https://www.robe.cz/robe-toolkit>.

The screenshot displays the ROBE Toolkit (1.0.0) interface. At the top, there is a green navigation bar with 'Device Updater', 'DISCOVER', 'GET DEVICE INFO', and 'Incremental' options. A warning banner at the top left states 'Using custom library folder (C:\Sample directory)!'. The main interface is divided into a left sidebar and a right main panel.

The left sidebar contains a search bar and a list of devices:

- ArtNet - 2.100.1.1 (0 devices)
- ROBE Universal Interface (1 device)
- Arianne6 (Arianne6) (52:53-01:66:00:10 | LIBu DMX) (Update Available (Board updates ava...))

The right main panel shows the 'Update Info - Arianne6 (Arianne6)' screen for the selected device (52:53-01:66:00:10). It features a 'CHANGELOG' tab and a 'Current Status' section indicating 'Board updates available' and 'Update Available'. Below this, a 'Library' section shows the version '26020262 -> 26020262 (02.02.2026 15:42:52)'. A 'Board versions' table lists various PCB components, all of which are marked as 'Will be updated [selected]':

Component	HW: 10, SW: 10 -> 10	Action
PCB D	HW: 10, SW: 10 -> 10	Will be updated [selected]
PCB M	HW: 10, SW: 10 -> 10	Will be updated [selected]
PCB L1	HW: 10, SW: 10 -> 10	Will be updated [selected]
PCB L2	HW: 10, SW: 129 -> 10	Will be updated [selected]
PCB L3	HW: 10, SW: 129 -> 10	Will be updated [selected]
PCB O	HW: 10, SW: 10 -> 10	Will be updated [selected]
PCB DL	HW: 10, SW: 10 -> 10	Will be updated [selected]
PCB GR	HW: 10, SW: 10 -> 10	Will be updated [selected]

At the bottom right of the main panel, there are two buttons: 'CHECK VERSIONS' and a prominent red 'UPDATE' button.

12. RDM

This fixture supports RDM operation. RDM (Remote Device Management) is a bi-directional communications protocol for use in DMX512 control systems, it is the new open standard for DMX512 device configuration and status monitoring.

The RDM protocol allows data packets to be inserted into a DMX512 data stream without adversely affecting existing non-RDM equipment. By using a special „Start Code,“ and by complying with the timing specifications for DMX512, the RDM protocol allows a console or dedicated RDM controller to send commands to and receive messages from specific moving lights.

RDM allows explicit commands to be sent to a device and responses to be received from it.

The list of commands for Robin Arianne 6 is the following.

Parameter ID	Discovery command	SET command	GET command
DISC_UNIQUE_BRANCH	*		
DISC_MUTE	*		
DISC_UN_MUTE	*		
DEVICE_INFO			*
SUPPORTED_PARAMETERS			*
SOFTWARE_VERSION_LABEL			*
DMX_START_ADDRESS		*	*
IDENTIFY_DEVICE		*	*
DEVICE_MODEL_DESCRIPTION			*
MANUFACTURER_LABEL			*
DEVICE_LABEL		*	*
SENSOR_DEFINITION			*
SENSOR_VALUE			*
DISPLAY_INVERT		*	*
DISPLAY_LEVEL		*	*
PAN_INVERT		*	*
TILT_INVERT		*	*
DEVICE_RESET		*	
DMX_PERSONALITY		*	*
DMX_PERSONALITY_DESCRIPTION			*
STATUS_MESSAGES			*
STATUS_ID_DESCRIPTION			*
DEVICE_HOURS ²			*
ROBE_DMX_INPUT		*	*
ROBE_WIRELESS_UNLINK		*	

²...Commands relative resettable values

RDM model ID for the Robin Arianne 6 is 0x0166.

13. NFC

The fixture supports NFC. Using the mobile phone application ROBE COM you can read and set the Robin Arianne 6 parameters (DMX address, IP address...etc.), get information about temperatures, operation hours, RDM identification etc.

The NFC point is situated on the front panel of fixture's base.

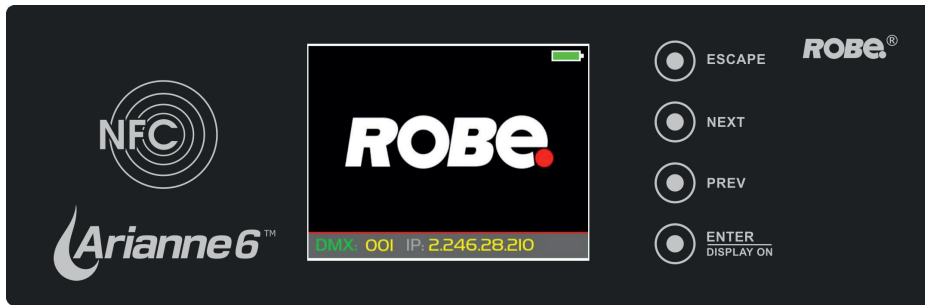

Download and install the ROBE COM from Google Play (for Android 7.1 and higher) or App Store (for iOS 15.0 and higher) to your mobile phone. Your mobile phone has to support NFC.

After installing the ROBE COM, run the application by touching the icon  .

Hold the mobile phone on the side of the fixture base near to NFC point , if NFC connection is OK, touch the item "SETUP DEVICES", then "Arianne 6" and the following menu items will appear:

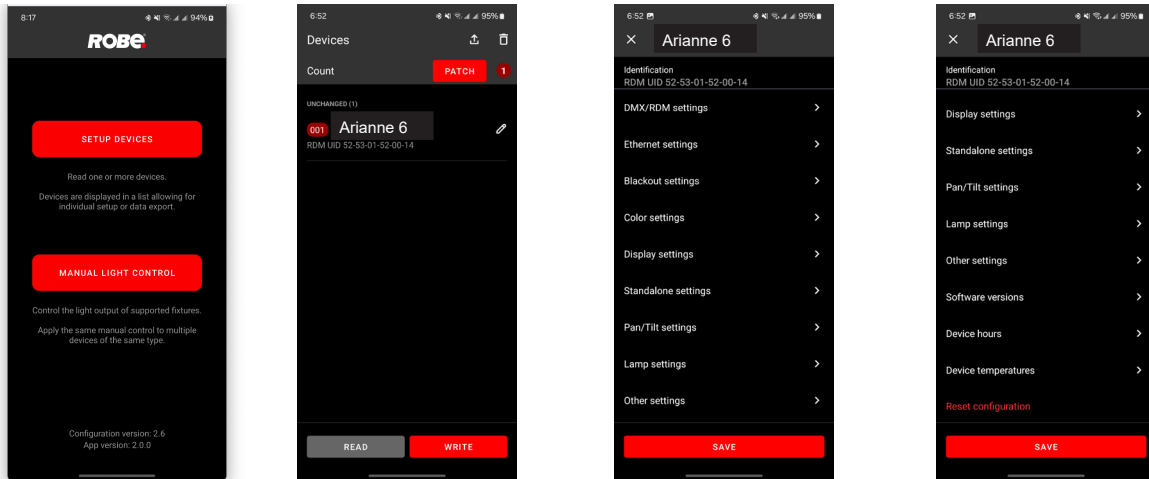

Note. Displayed menu is universal, some menu item can be disabled for specific types of fixtures. The fixture can be disconnected from mains during loading and saving data to the fixture, but some changes will be active after switching the fixture on.

Changes made in selected menu item can be saved by touching the item "SAVE". The item "WRITE" sends all changes to the fixture.

Menu item "MANUAL LIGHT CONTROL" currently serves for Anolis fixtures (Lyrae S, Lyrae M) only.

14. Error and information messages

Error in the fixture is signalled by the yellow warning icon at the bottom line of the screen:

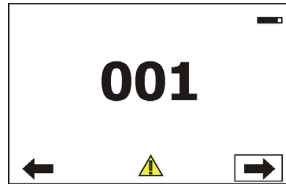

Use NEXT] or [PREV] button to highlight warning icon and press [ENTER] button to display error messages.

List of error and information messages:

Pan Error 1

Mechanical end of the pan track was not detected.

Pan Error 2

Pan sensor error.

Pan Error 3

Pan feedback error.

P/T Blackout Active

Light output from the fixture was closed. This blackout was enforced by the following effect: pan or tilt.

Pan Reset Active

Pan reset is in progress and has not been fished yet.

Tilt Error 1

Mechanical end of the tilt track was not detected.

Tilt Error 2

Tilt sensor error.

Tilt Error 3

Tilt feedback error.

Tilt Reset Active

Tilt reset is in progress and has not been fished yet.

Zoom Error 1

Impact to the mechanical end of the zoom track was not detected.

Zoom Error 4

Incorrect detection of a zoom track. Impact to a mechanical obstruction was detected within running of the zoom.

F/Z Blackout Active

Light output from the fixture was closed. This blackout was enforced by the following effect: zoom.

Zoom Reset Active

Zoom reset is in progress and has not been fished yet.

P/T board EMS calibration needed

The EMS system is not calibrated. Run the item "Calibrate Pan/Tilt EMS" in the tab "Service"

Gyro board EMS calibration needed

The EMS system is not calibrated. Run the item "Calibrate Pan/Tilt EMS" in the tab "Service"

PROC X COMM ERR (e.g. PROC 2 COMM ERR)

Internal communication error - some PCB in the fixture is faulty.

Too Much Humidity in Device

To remove the message, reset the bar chart Max.Wet in the menu RAINS Status (tab Information) and check the silica gel desiccant in the fixture arm.

Valve Seal Error

The valve in fixture head or coil in the valve is defective or there is a connection problem between the valve and head, check cable connector at valve.

Recharge The battery

The battery on the display board needs to be charged. Let the fixture on for cca 6 hrs.

15. Cleaning

Regular cleaning will not only ensure the maximum light output, but will also allow the fixture to function reliably throughout its life.

The frequency of cleaning depends on the environment in which the fixture operates: damp, smoky or particularly dirty environments can cause greater accumulation of dirt on the fixture housing.

The front glass cover of the head will require cleaning on a monthly basis.

A soft lint-free cloth dampened with a solution of water and a mild detergent is recommended, under no circumstances should alcohol, solvents or abrasives be used!

DANGER !

Always disconnect the fixture from mains before starting any cleaning or maintenance work.

Important! Never use alcohols (ethanol, methanol, isopropyl alcohol), acetone and another aggressive solvents for cleaning the front lens array. Do not immerse lenses in liquid (e.g. water) during cleaning.

Potential stains on fixture covers caused by hard water (water that has high mineral content) can be effectively removed by means of non-abrasive descaler (e.g. EverStar descaler).

Note: potential foggy front lens array does not influence function of the fixture and does not subject to complaint.

Do not remove fixture covers in smoky or particularly dirty environment (e.g. with fog machines).

Cleaning the front lens array.

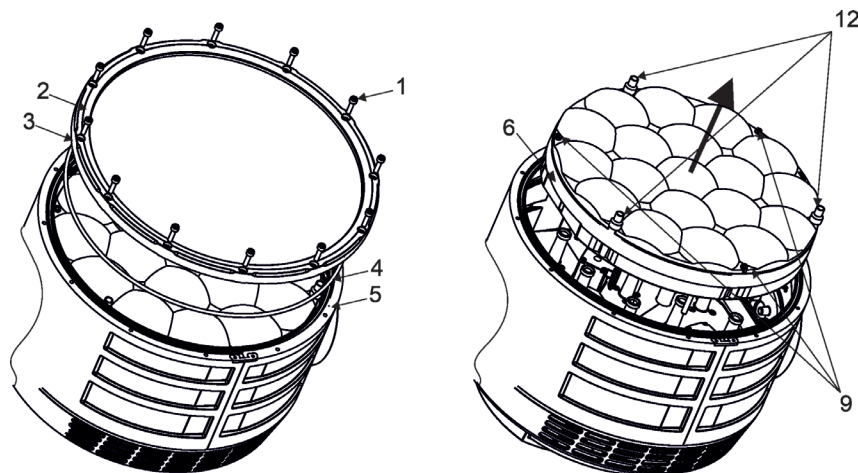

Keep correct orientation of wide and narrow apertures!!

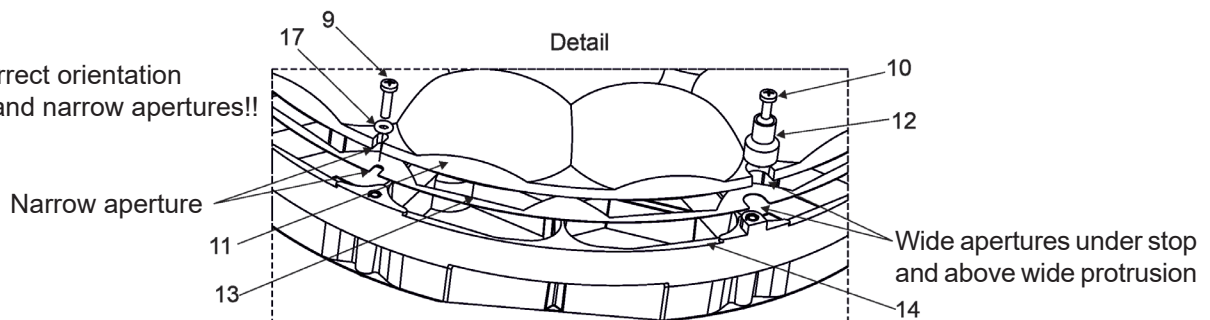

Before cleaning the front lens array, disconnect the fixture from mains.

1. Unscrew 12 screws (1) on the fixture head and remove the flange (2) and the glass cover (3).
2. Unscrew three screws M3x12 (9) with small rings (17) and three stops (12) by screws M3x8 (10) and remove the lens array (11) from the bottom part (14) of the optical module. Do not touch optical module with bare hands, always use gloves.

Recommended steps for cleaning the lens array:

1. Use low-pressure compressed air to remove coarse dust from lenses.
 2. Use distilled water with weak detergent solution and lint-free small cloth for further cleaning of lenses.
 3. Use an antistatic, alcohol-free screen cleaner (we recommend the Lyreco Screen Cleaner) and polish lenses until they are dry.
 4. Check the lenses are dry before screwing the front lens array back to the fixture.
3. Screw the front lens array (11) with foil (13) to the bottom part (14) of the optical module by means of three screws (9) M3x12 (9) with small rings (17). Screw three stops (12) by means of the screws M3x8 to the bottom part (14) of the optical module.
4. Place the glass cover (3) with flange (2) on the head, check the gasket (4) is correctly placed in the chassis (5) and screw the flange by means of 12 screws (1). Use a tightening torque as stated in the chapter "Torques for watertight covers".
 5. After connecting the fixture to mains, run the procedure Pressure Test (tab Service -->Pressure Test).

16. Maintenance

In order to ensure the fixture remains in good condition and does not fail prematurely, we recommend regular maintenance.

The following points have to be considered during fixture inspection:

- All outside covers and screws should be checked for damages, scratches or corrosion.
- All connectors and its rubber caps should be checked for damages or sediments.
- All screws and fasteners has to be securely tightened. Check for any deformation on the housing and rigging points. Damaged rigging points or unsecured rigging could cause the fixture to fall and seriously injure people.
- Electric power supply cable must not show any damage or material fatigue.
- Fans and heatsink should be checked for sediments or dirt/debris accumulation.

User can do the following operations:

- main fuse replacement
- battery replacement
- silica gel desiccant replacement
- lens cleaning

Another maintenance, cleaning and service operations should be carried out by trained technicians only. If you need any spare parts, please order genuine parts from your local Robe distributor.

Fixture metal covers are made of material resistant to corrosion, potential damages of covers (like scratches, abrasions) are only appearance defects and will not cause corrosion of covers.

To repair small damages of fixture metal covers (e.g. scratches), you can use a paint intended for non-rusting metal surfaces (like aluminium, copper...). The paint can be applied to surface by means of a small brush or by spraying.

Use the paint with the same colour and sheen as has your cover. The paint can perform as undercoat or top-coat, it does not matter.

Do not remove fixture covers in smoky or particularly dirty environment (e.g. with fog machines).

IMPORTANT: in case of service intervention, the front glass cover (or base cover) should be removed as short time as possible (about 1-2 hours depending on air humidity) otherwise silica gel in the small box (boxes) in the fixture head (base) may become damp.

If you have removed front glass cover (or base cover) and you need to interrupt your service work for long time (hours, days), we recommend to place the front glass cover on the head (base cover on the base) and fasten it provisionally by means of two screws, another possibility is unscrewing small box (boxes) with silica gel from the head (base) and put it (them) to a sealed container with limited access of air (e.g. sealed plastic bag).

Checking plastic parts of the fixture.

The plastic parts of the fixture should be checked for damages and beginning cracks at least every two months. If hint of a crack is found on some plastic part, do not use the fixture until the damaged part will be replaced. Cracks or another damages of the plastic parts can be caused by the fixture transportation or manipulation and also aging process may influence plastic materials.

This checking is necessary for both fixed installations and preparing fixtures for renting. Any free moving parts inside of the fixture head, cracked plastic or any plastic part not sitting properly in place need to be immediately replaced.

Replacing the fuse.

Before replacing the fuse, disconnect the fixture from mains.

1. Remove the cover (1) of the battery and fuse compartment by unscrewing four screws (4) with sealing rings (3).
2. Using a flat-blade screwdriver, unscrew (anti-clockwise) the fuse holder from the rear panel of the base.
3. Remove the blown fuse from the fuse holder.
4. Place a good fuse (only the same type and rating) into the fuse holder and screw the fuse holder back.
5. Place the cover (1) with gasket (4) back on the rear panel of the fixture and fasten it by means of the four screws (2) with sealing rings (3). Tighten screws crosswise in two steps:
 - Step 1 - use tightening torque 0.5Nm (pre-tightening)
 - Step 2 - use tightening torque 2.5Nm (final tightening)

Replacing the battery.

Before replacing the battery, disconnect the fixture from mains.

1. Remove the cover (1) of the battery and fuse compartment by unscrewing four screws (2) with sealing rings (3).
2. Loosen (anti-clockwise) the battery holder cap.
3. Remove the exhausted battery from the battery holder.
4. Place a new battery (only the same type) into the battery holder (Negative (-) inside, Plus (+) outside).
5. Place and tighten the battery holder cap back.
6. Place the cover (1) with gasket (4) back on the rear panel of the fixture and fasten it by means of the four screws (2) with sealing rings (3). Tighten screws crosswise in two steps:
Step 1 - use tightening torque 0.5Nm (pre-tightening)
Step 2- use tightening torque 2.5Nm (final tightening)

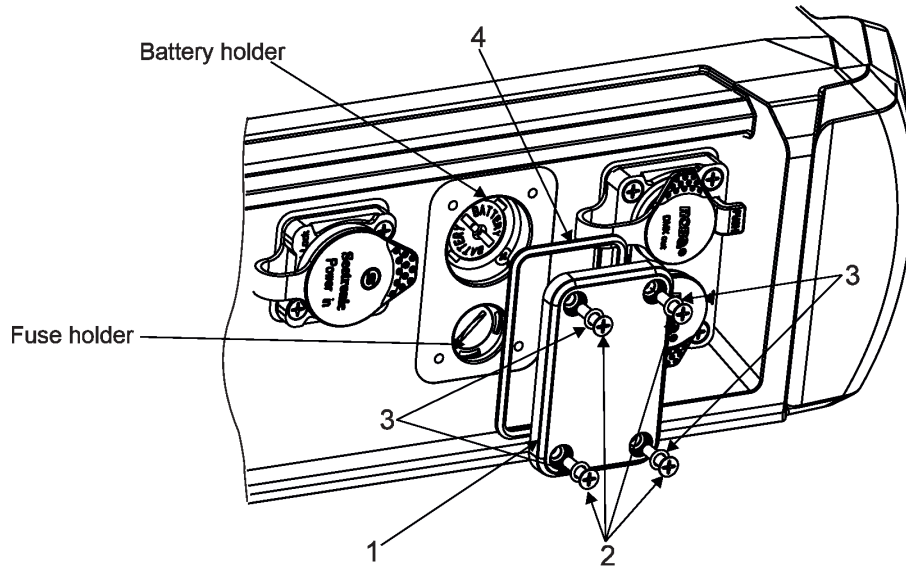

16.1 Torques for watertight covers

Keep values of torques as stated on pictures below otherwise leakage issues can occur.
Run the procedure Pressure Test (Service --> Pressure Test) after replacing any watertight cover!

Bottom base cover

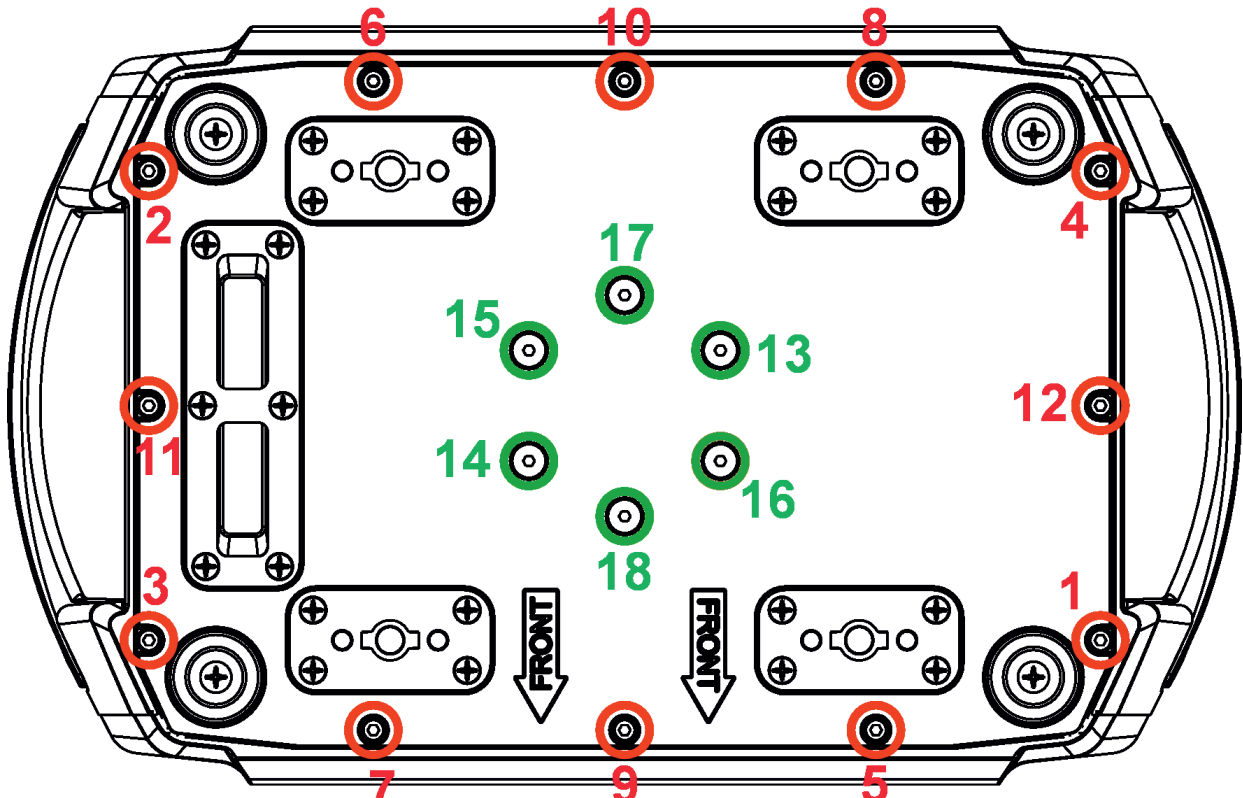

Screws must be tightened
in the order 1-->12
13-->18.

- 12 x hex socket head screw M4x12
Tightening torque*: 2.5 Nm
- 6 x flat head screw M5x16 with rubber ring
Tightening torque*: 2.5 Nm

* Tighten all screws in two steps:
Step 1 - use tightening torque 0.5 Nm (pre-tightening)
Step 2- use tightening torque 2.2-2.5 Nm (final tightening)

**Carefully check the gasket for signs of deformities or damages and if it is correctly placed before screwing the bottom base cover back. The gasket is part of base.
Do not forget to connect grounding wire between chassis and base cover.**

Yoke cover

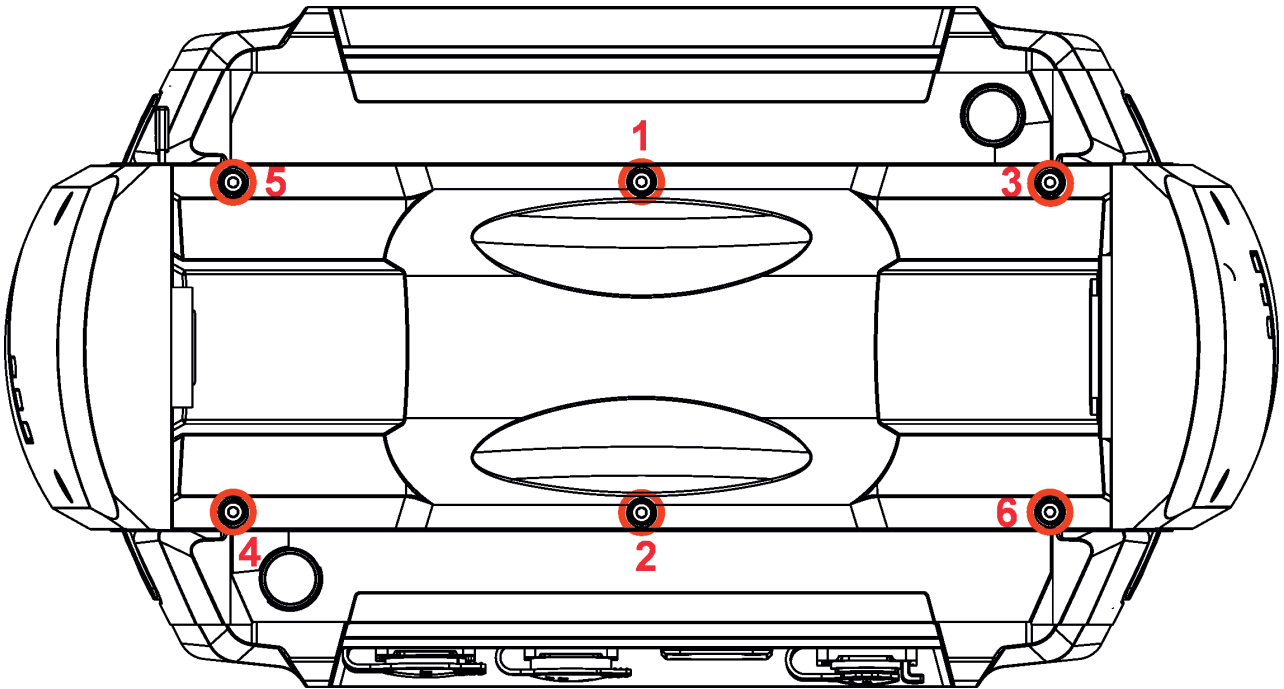

Screws* must be tightened
in the order 1-->6.

6 x hex socket head screw M4x8
Tightening torque: 2.5-3 Nm

* Tighten all screws in two steps:

Step 1 - use tightening torque 0.5 Nm (pre-tightening)

Step 2- use tightening torque 2.5-3 Nm (final tightening)

Carefully check the gasket for signs of deformities or damages and if it is correctly placed before screwing the yoke cover back. The gasket is part of chassis.

Do not forget to connect grounding wire between chassis and yoke cover.

Head flange with glass cover

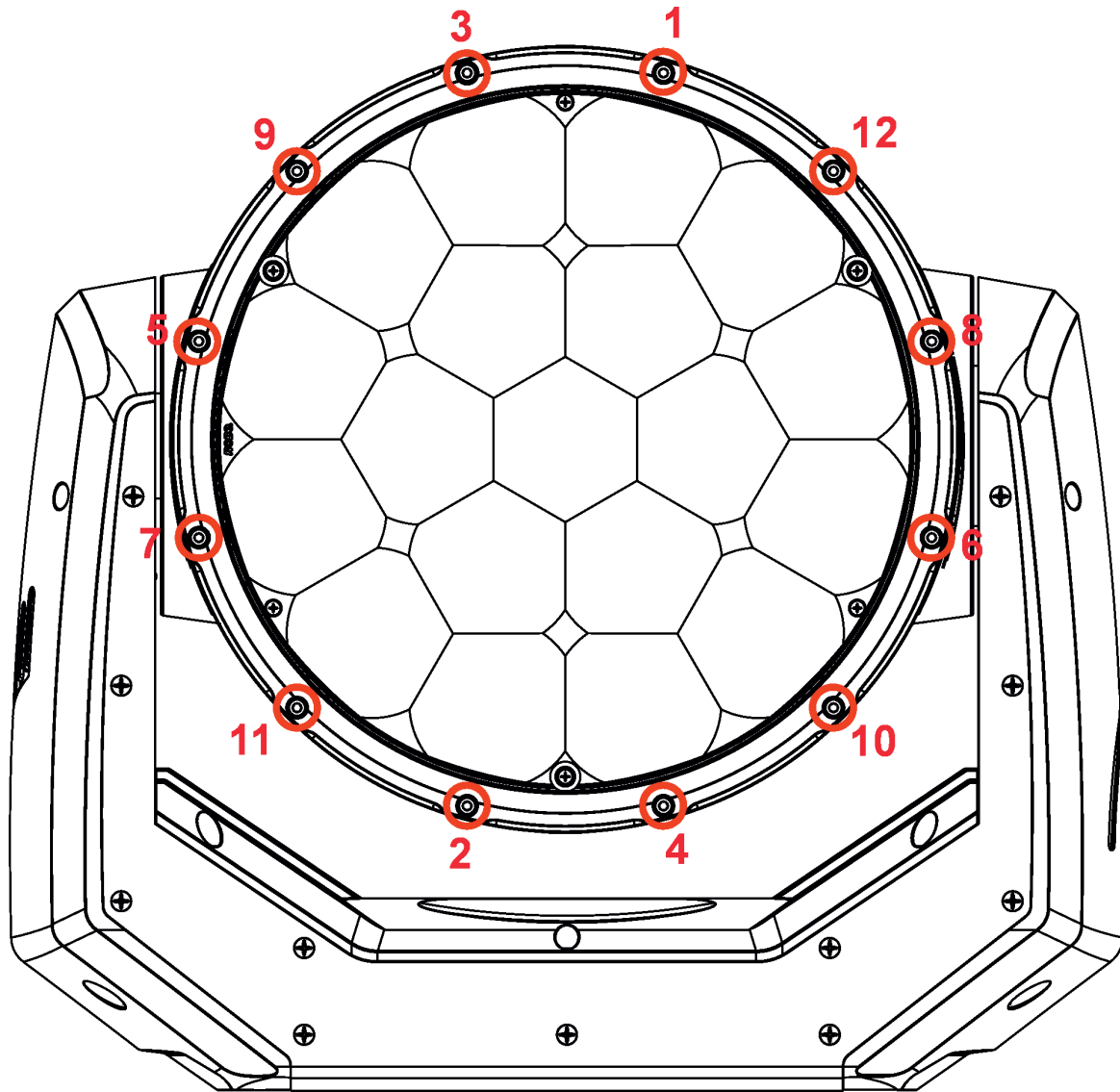

Screws* must be tightened
in the order 1-->12.

12 x hex socket head screw M4x16
Tightening torque: 2-2.2 Nm

* Tighten all screws in two steps:

Step 1 - use tightening torque 0.5 Nm (pre-tightening)

Step 2- use tightening torque 2-2.2 Nm (final tightening)

Carefully check the gasket for signs of deformities or damages and if it is correctly placed on the glass cover before screwing the head flange back.

16.2 Torques of Pan/Tilt motors screws

Tilt motor

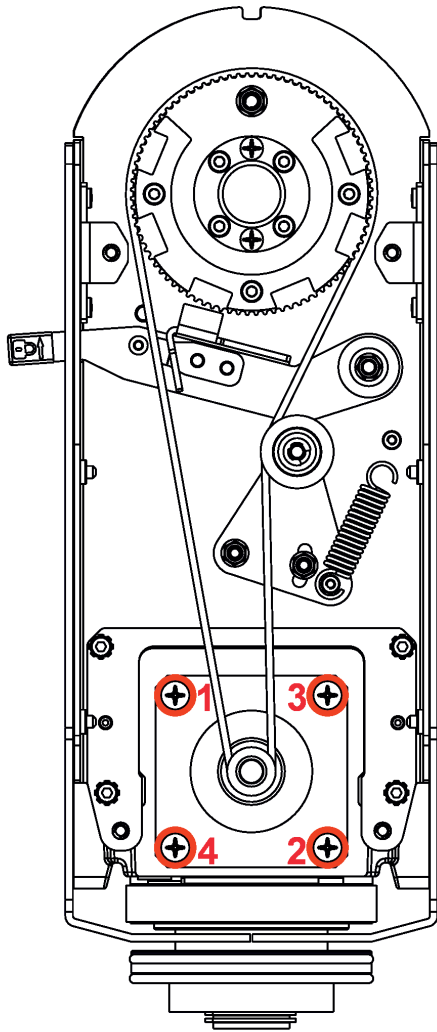

4 x flat head screw M5x16 (stainless)
with sealing ring 5x1.5
Tightening torque*: 2.5 Nm

Screws must be tightened in the order 1-->4,

* Tighten all screws in two steps:
Step 1 - use tightening torque 0.5Nm
(pre-tightening)
Step 2- use tightening torque 2.5Nm
(final tightening)

Pan motor

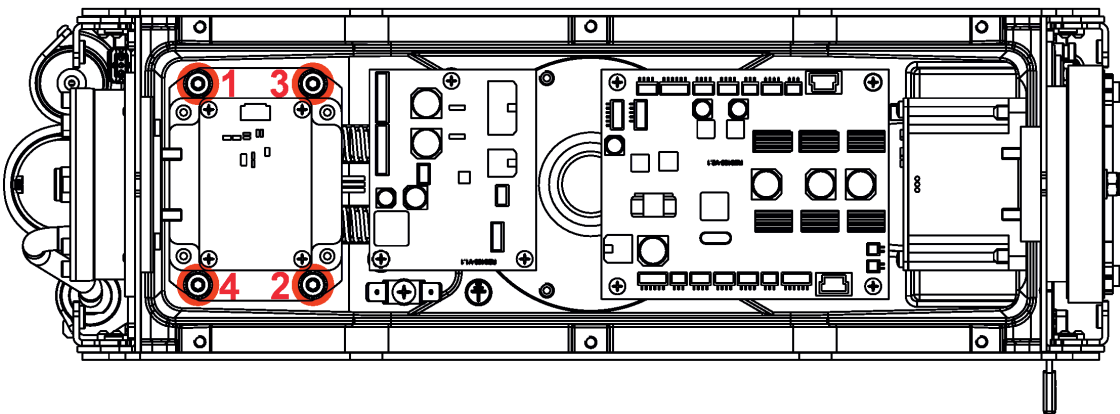

4 x hex socket head screw M4x12 (stainless) with
washer

Tightening torque*: 2.5 Nm

Screws must be tightened in the order 1-->4.
Use LOXEAL 55.03 (nut locking threadsealing)
on each screw

* Tighten all screws in two steps:
Step 1 - use tightening torque 0.5Nm (pre-tightening)
Step 2- use tightening torque 2.5Nm (final tightening)

16.3 Checking and replacing the silica gel desiccants

The silica gel desiccants are used for humidity indication in the fixture. Dry silica gel has an orange colour, if it is saturated with water, its colour changes to dark grey. If most of silica gel changed colour to dark grey, it has to be replaced.

***Unplug the fixture from mains before checking/replacing silica gel desiccant!
Do not check/replace silica gel desiccant in a damp environment (e.g. rain, snowfall)!***

***Spare desiccants from factory are packaged in a protective foil. Take desiccants out of the protective foil immediately before replacing them in the fixture!
Silica gel may become damp if it is exposed to wet air for longer time.***

Silica gel is not under warranty.

Desiccants are placed in the fixture in the following places:

fixture base - 2 x small box with silica gel on the cover of base

fixture head - 1 x narrow box with silica gel

fixture arm - 1 x tube with silica gel

Fixture base

Boxes with silica gel

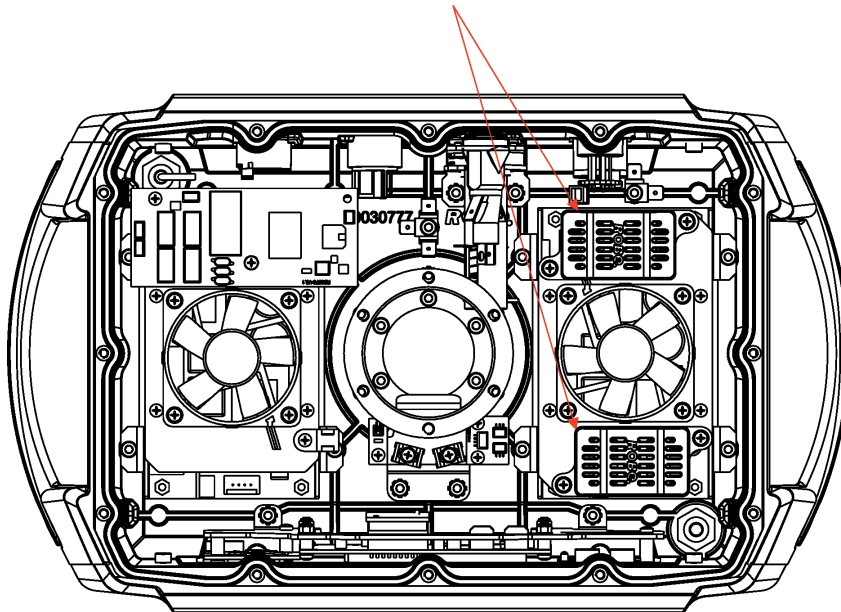

Each box with silica gel is fastened by means of two screws.

The silica gel desiccants in the fixture base should be checked (or alternatively replaced) at removing bottom cover e.g. at service intervention.

After checking/replacing boxes with silica gel do not forget to connect grounding wire between chassis and the base cover at placing the base cover back.

After checking/replacing boxes with silica gel, run the procedure Pressure Test (Service -->Pressure Test).

If the pressure test is not OK, check if all screws of base cover are correctly tightened and run the test again.

Examples:

Dry silica gel



Silica gel saturated with water



Fixture arm

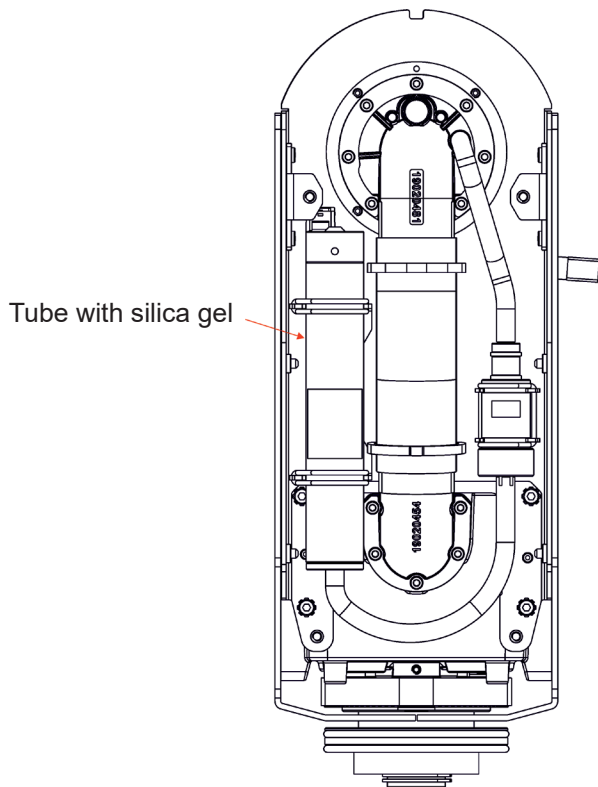

Example of dry and wet silica gel

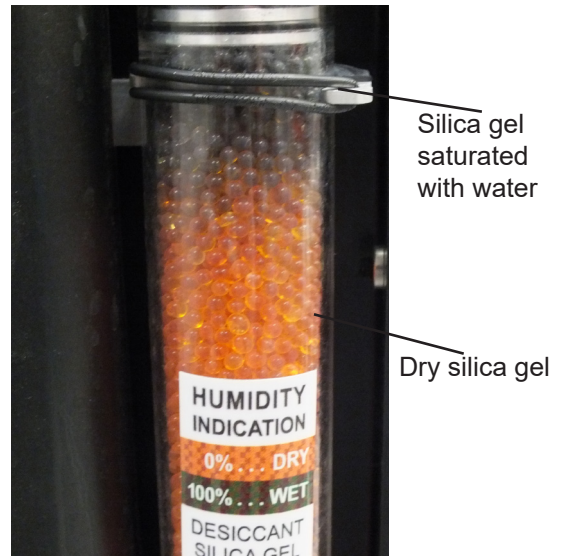

To change the tube with the silica gel in the fixture arm.

1. Disconnect the fixture from mains.
 2. Remove the arm cover.
 3. Disconnect the hosepipe from the tube with silica gel.
 4. Stick out the rubber rings (2) and remove the tube with silica gel.
 5. Insert the new tube with silica gel and secure it by means of the rubber rings (2).
 6. Connect the hosepipe (1) to the tube with silica gel.
 7. Screw the arm cover back.
 8. **After connecting the fixture to mains, reset the MAX WET chart (tab Information-->RAINS Status) and run the procedure Pressure Test (tab Service -->Pressure Test).**
- If the pressure test failed, check if hosepipes are correctly put on the tube with silica gel.

State of desiccants in the fixture arm can be checked:

- visually by unscrewing the cover of fixture arm
- via fixture display (tab Information, option RAINS Status):

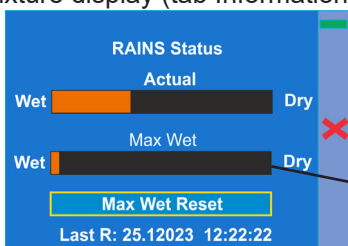

- remotely by means of the Robe Ethernet Access Portal (REAP):

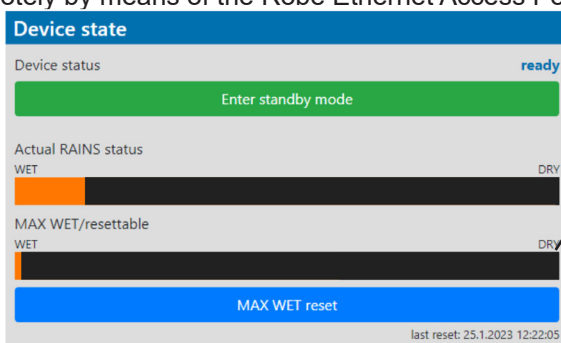

The chart MAX WET is decisive for replacing desiccant in the fixture arm. If the chart has changed to black colour, desiccant has to be replaced.

It is not necessary to replace silica gels desiccants in plastic boxes in the fixture head and base. These desiccants should be checked (and replaced if it is needed) at removing head or base covers, e.g. at some service intervention.

In case that silica gel in the fixture arm is fully saturated with water, the warning message "**Too Much Humidity in Device**" will appear on the fixture display (yellow warning icon) and also in the Robe Ethernet Access Portal (Logs screen).

Example

Status messages

Too Much Humidity In Device

Fixture head - front side under lens array

Box with silica gel

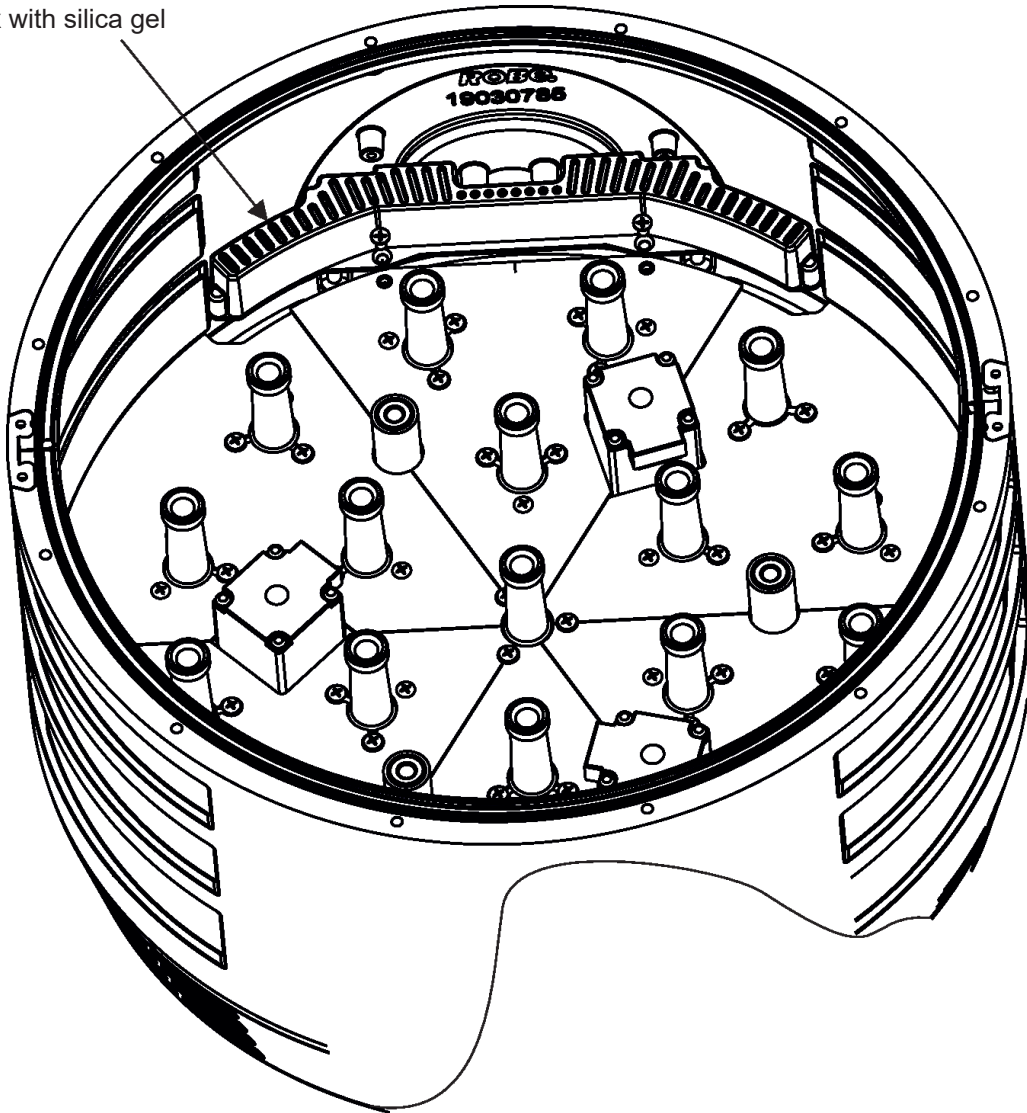

To change the box with silica gel in the fixture head.

1. Disconnect the fixture from mains.
2. Unscrew 12 screws (1) on the fixture head and remove the flange (2) and the glass cover (3).
Check, that the gasket (4) is correctly placed in the groove of the chassis (5).

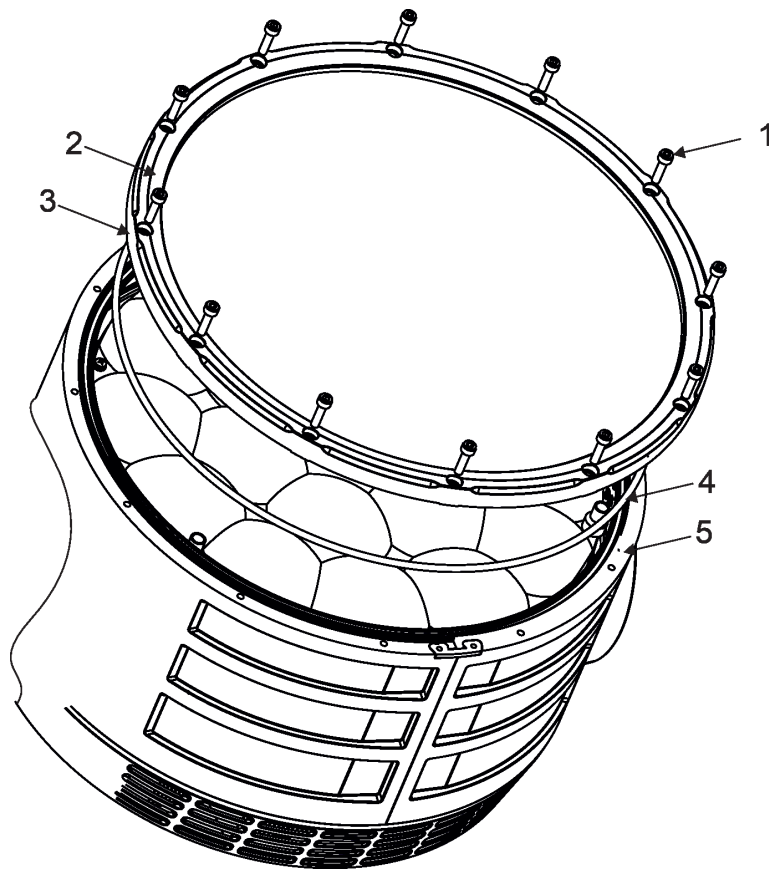

3. Carefully take the optical module (6) out of the fixture head. Do not touch optical module with bare hands, always use gloves.

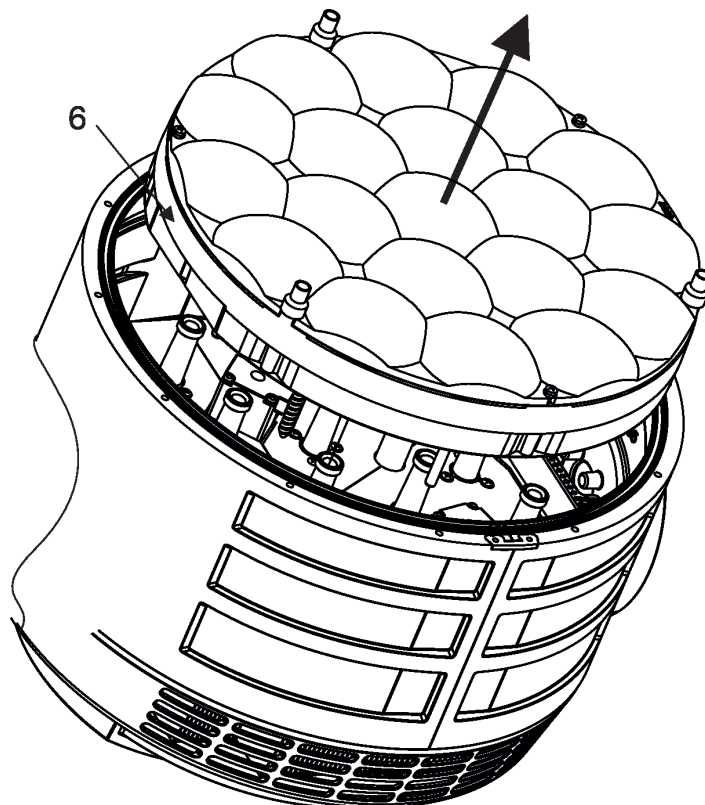

4. The box (7) with silica gel is fastened to the head by two screws (8). Check the box with silica gel and replace it if necessary.

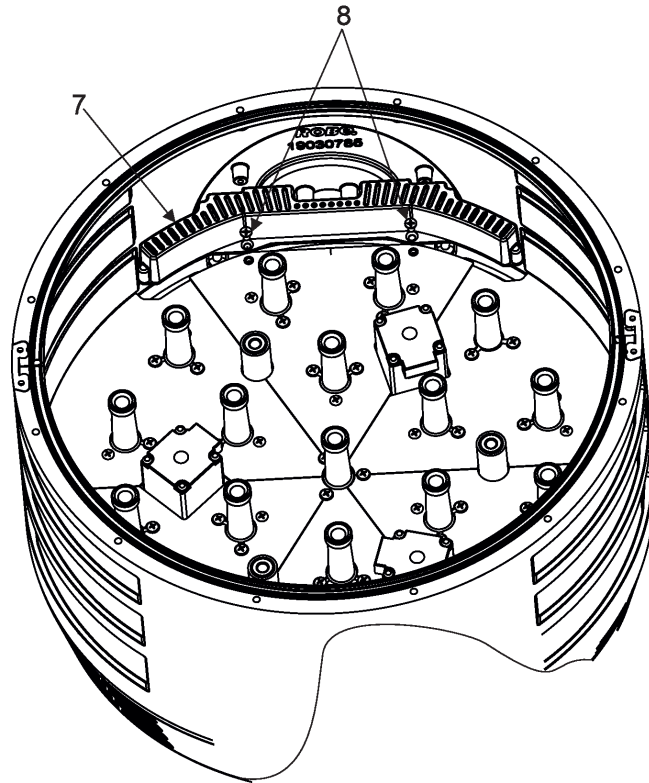

5. To insert the optical module back to the head, the optical module has to be unscrewed. Unscrew three screws M3x12 (9) with small rings and three stops (12) fixed with screws M3x8 and remove the lens array (11) with foil (13) from the bottom part (14) of the optical module.
6. Connect the fixture to mains and after fixture reset go to the tab Manual Control, select items Pan and Tilt and set them at 128 DMX and Zoom set at 255 DMX.
7. Put the bottom part (14) of the optical module to the head in such a way that three guide-pins (15) aim into guide-tubes (10) and three lead helices (16) aim into motors (9).
8. Hold the bottom part (14) of the optical module in this position and slowly change the item Zoom from 255 DMX to 0 DMX. Motors "draw" the bottom part (14) of the optical module back to the head. DO NOT TRY TO INSERT THE OPTICAL MODULE TO HEAD BY A FORCE!

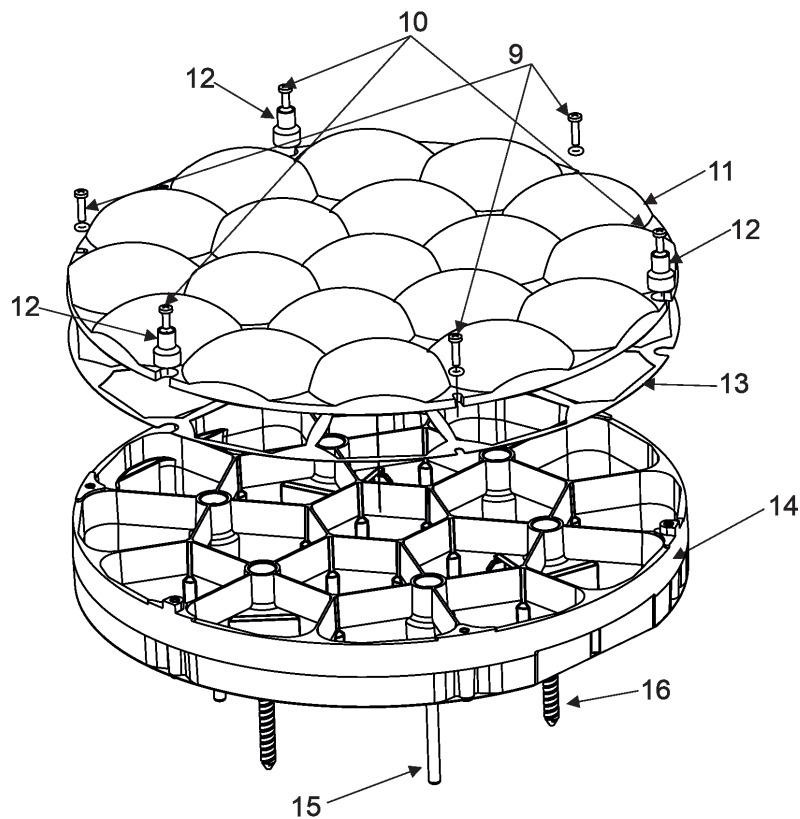

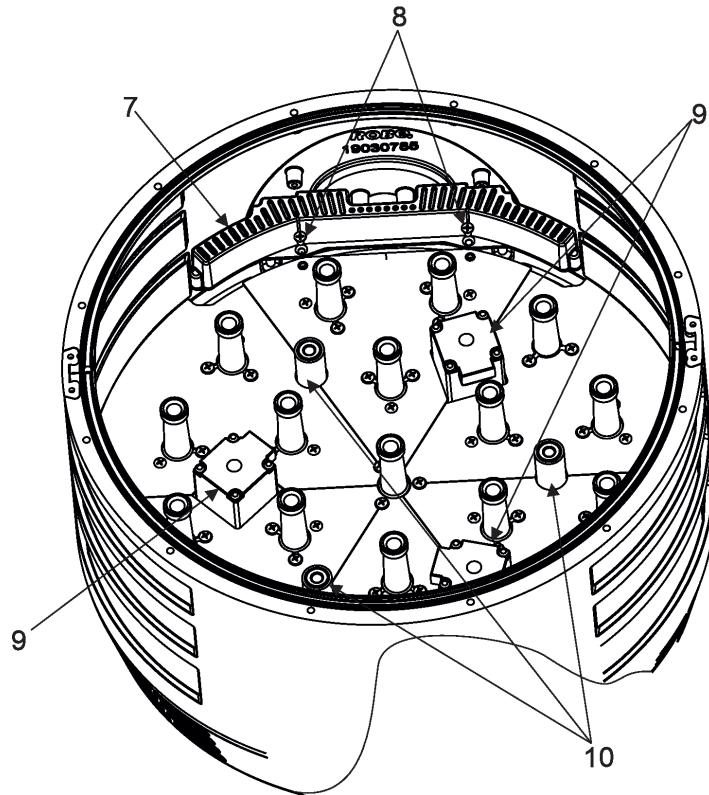

- 9. Run the option Zoom Reset from tab Manual Control.
- 10. Disconnect the fixture from mains.
- 11. Screw the front lens array (11) with foil (13) to the bottom part (14) of the optical module by means of three screws (9) M3x12 (9) with small rings (17). Screw three stops (12) by means of the screws M3x8 to the bottom part (14) of the optical module.
Do not touch lens array bare fingers - use a suitable gloves.

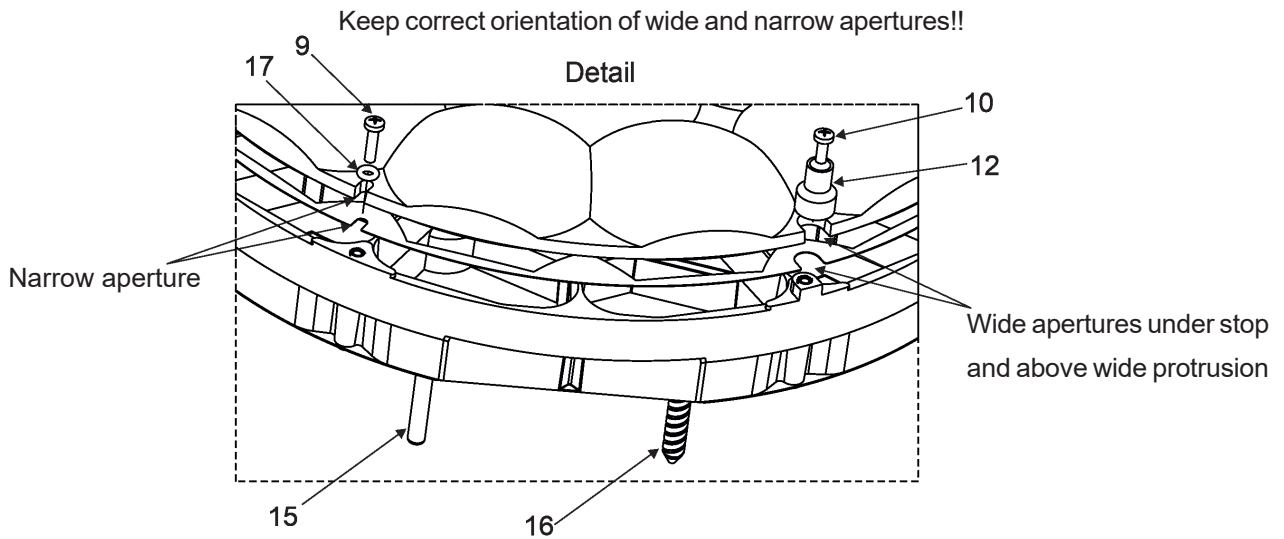

12. Place the glass cover (3) with flange (2) on the head, check the gasket (4) is correctly placed in the chassis (5) and screw the flange by means of 12 screws (1). Use a tightening torque as stated in the chapter "Torques for watertight covers".
13. After connecting the fixture to mains, run the procedure Pressure Test (tab Service -->Pressure Test).

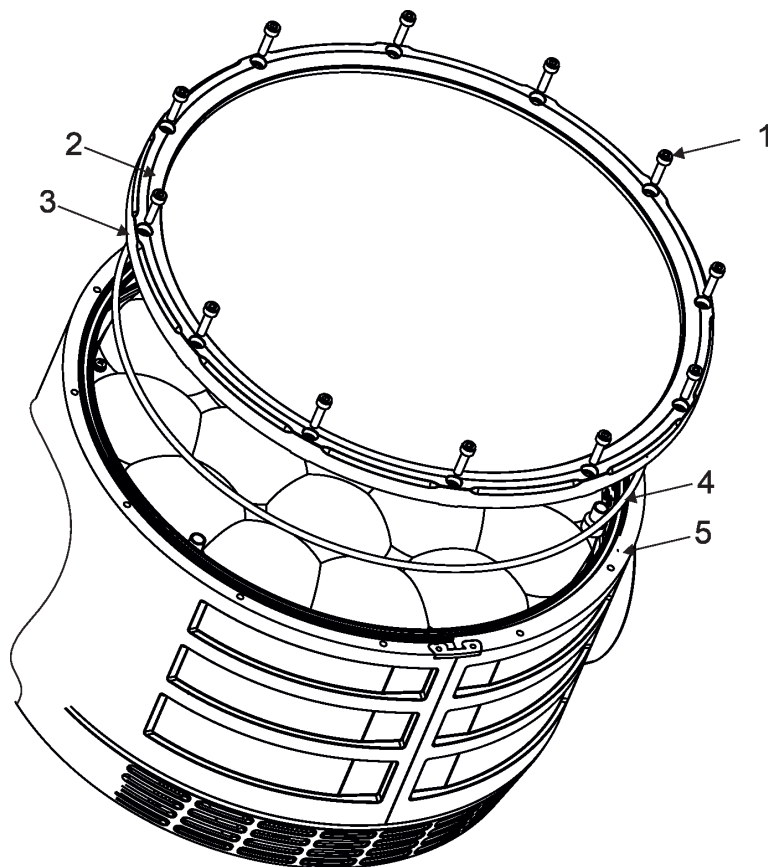

17. Robe Ethernet Access Portal (REAP)

Before running the REAP, your computer needs to be connected to the fixture (s) through the means of Ethernet wired network and a network switch. The computer needs to have configured network settings in order to be able to communicate with the fixture(s) through the network. The Ethernet network connection (Local LAN) typically needs to be set to 2.x.x.x address, the computer IP address has to be set to 2.x.x.x (for example 2.247.136.20) with netmask 255.0.0.0. On the fixture make sure to use the default 2.x.x.x IP address as provided. You do not need change any IP settings on the fixture, There is no need to set the fixture into Art-Net mode.

Type the IP address of the Arianne 6 to your web browser, e.g. <http://2.249.212.16>, enter the user name: **robe** and the password: **2479**, the **Status screen** of the Arianne 6 will appear.

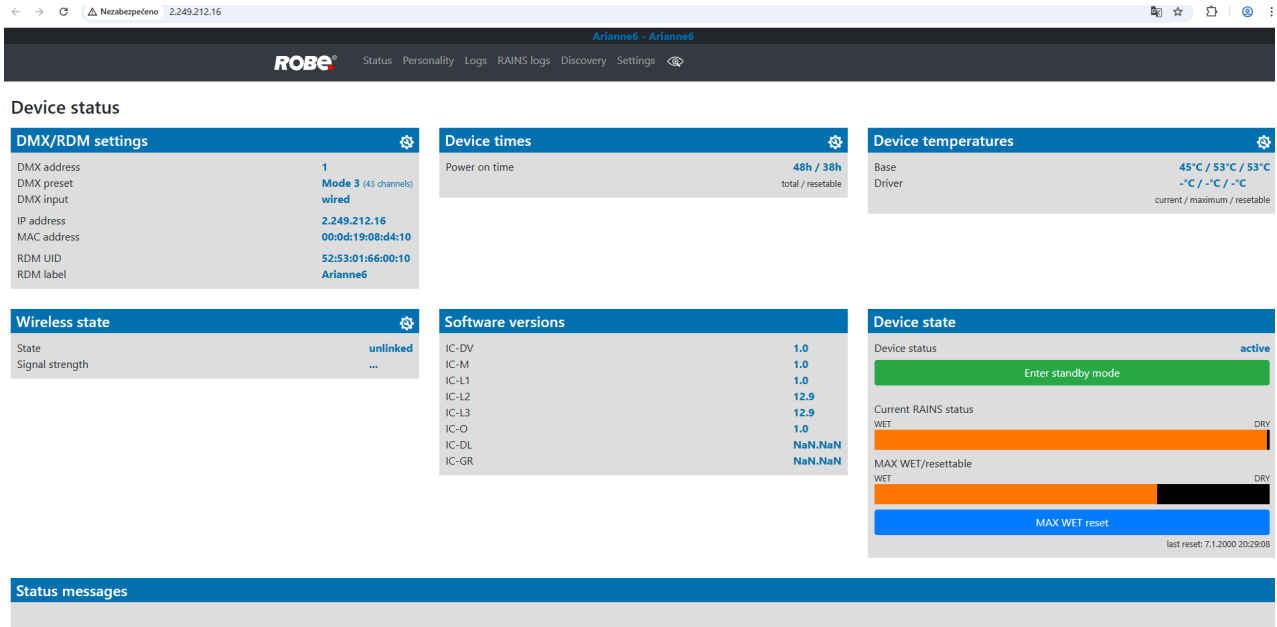

This screen gives you a fast overview of fixture settings and environment in the fixture. The icon  allows you to change some values in a corresponding table.

Example for DMX/RDM settings:

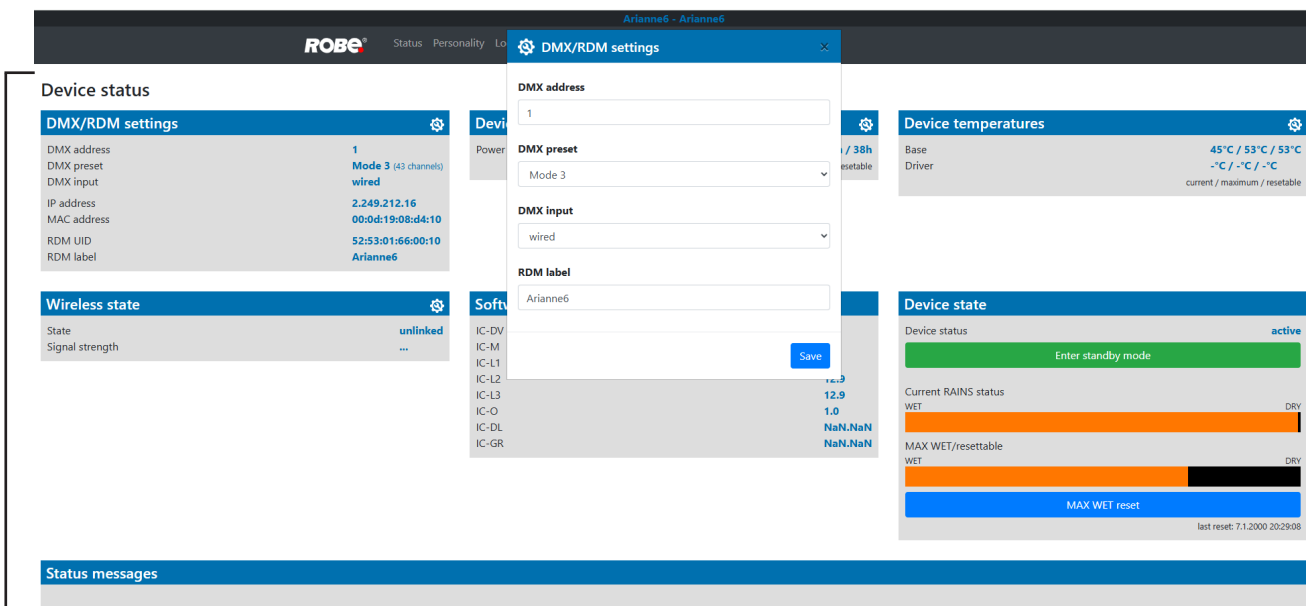

Note.

The background colour of the top row of the Status screen with the name and RDM label of the fixture denotes state of the fixture:

	fixture is ready for operation
	fixture does not communicate with computer
	fixture with error message(s)

The table "Device state" gives you information about fixture and environment in the fixture.

Device status: **ready** - all fixture resets successfully passed and the fixture is ready for operation.

initialization - fixture is waiting for fixture reset

heating - fixture is waiting for reaching operating temperature of the fixture inside (temperature in the fixture is below 0°C).

standby - the fixture is in standby mode

standby/heating - the fixture is in standby mode and inside of the fixture is heated

The bar chart **Actual RAINS status** informs you about current humidity in the fixture. The bar chart changes depending on humidity, temperature and pressure in the fixture. The bar chart depends on current conditions in the fixture and can be different at start of fixture operation, after 10 minutes of its operating, after closing fixture dimmer etc.

RAINS (Robe Automatic Ingress Neutralization System) manages humidity, temperature and pressure control using an active monitoring system to automatically remove any moisture detected within the fixture and provides permanent monitoring to ensure peak performance of the fixture.

The bar chart **MAX WET/resettable** informs you about maximum humidity achieved in the fixture since the chart was last reset. The bar chart also informs you about saturation of silica gel desiccant in tube in the fixture head with water and is deciding indicator for its checking and replacement.

The blue button **MAX WET reset** resets the bar chart MAX WET/resettable. Date and time of last reset is displayed below this button.

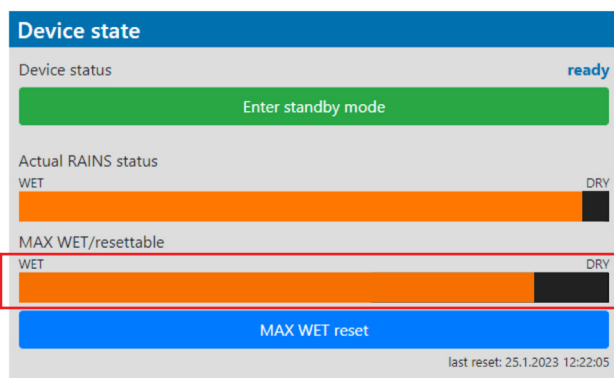

Silica gel desiccant in the fixture arm

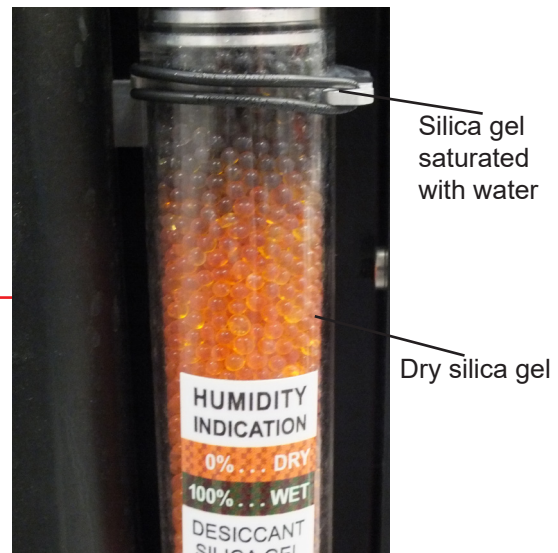

Silica gel saturated with water

Dry silica gel

Examples of the table "Device state":

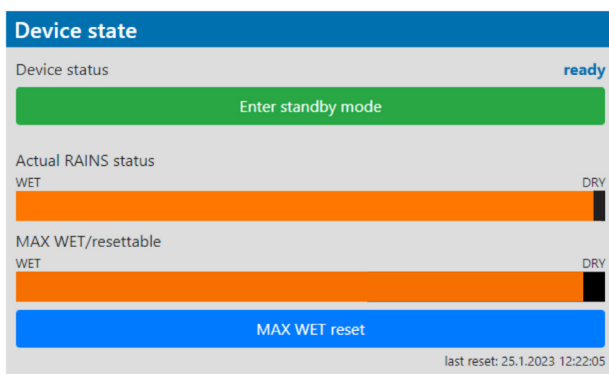

Dry desiccants

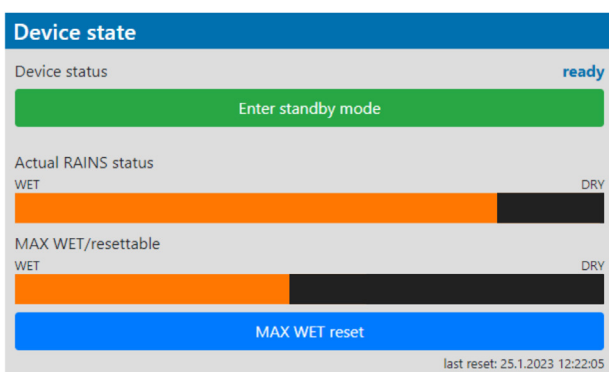

Desiccants partially saturated with water

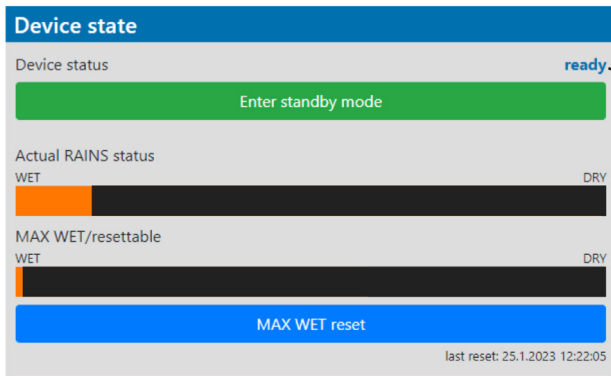

Device status **ready** means, that all fixture resets are OK and the fixture is ready for operation. It does not assess state of desiccants or result of pressure test!

Desiccants fully saturated with water

Silica gel desiccant in tube in the fixture head should be replaced.

After replacing it, reset MAX WET resettable bar chart.

It is not necessary to replace silica gels desiccants in plastic boxes in the fixture head and base. These desiccants should be checked (and replaced if it is needed) at removing head or base covers, e.g. at some service intervention.

The option **Enter standby mode** allows you to switch the fixture to Standby mode.

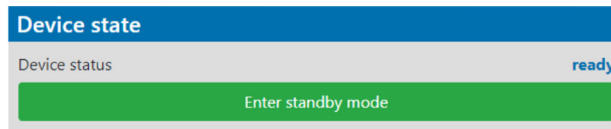

Note: Standby mode helps conserve power when a fixture is not in use, without fully powering it off. In the Standby mode, all fixture motors and fans are deactivated and light output is closed. For more information about Standby mode please see the chapter Standby mode.

The option **Escape standby mode** allows you to switch the fixture to standard operating mode.

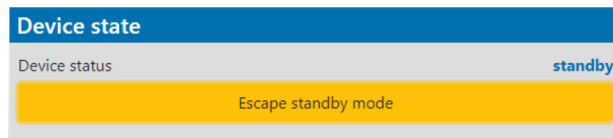

The **Personality** screen allows you to set fixture behaviour and run a pressure test.

The screenshot shows the ROBE Personality interface with the following settings:

- DMX/RDM settings:** DMX address: 1, DMX preset: Mode 3 (43 channels), DMX input: wired, RDM label: Arianne6.
- Ethernet settings:** Manual address: IP address 2.249.212.16, Network mask 255.0.0.0. Ethernet mode: Disable. Ethernet to DMX: off. ArtNet universe: 0. MANet I/II universe: 1. MANet session ID: 1. sACN universe: 1.
- Pan/Tilt settings:** Pan reverse: off, Tilt reverse: off, Pan/Tilt feedback: on, Pan/Tilt mode: speed.
- Blackout settings:** Blackout DMC: off, Active blackout while: on, Pan/Tilt moving: off.
- Display settings:** Display backlight: 100%, Display orientation: auto, On/Off timer: on.
- Color settings:** Colour mixing mode: RGBW, Tungsten effect simulation: off, White point: on, Dimmer curve: Square law.
- Date & time settings:** Date: 23.1.2000, Time: 21:51:16.
- Other settings:** Fan mode: Auto, Fan noise level: 50%, Fans blackout: on, Program auto run: None, Temperature unit: °C.
- Pressure test:** Start test button.

The icon  allows you to change values in a corresponding table.

Example for Ethernet settings:

The screenshot shows the Ethernet settings panel expanded with the following details:

- IP address:** 2.249.212.16
- Network mask:** 255.0.0.0
- Ethernet mode:** Disable (selected), ArtNet, gMA1, gMA2, sACN.
- Ethernet to DMX:** off (selected), on.
- ArtNet universe:** 0
- MANet I/II universe:** 1
- MANet session ID:** 1
- sACN universe:** 1

The table "Pressure test " with green button **Start test** allows you to run a procedure which checks IP65 integrity of the fixture. The fixture has to be connected to mains and the head temperature (at pressure sensor) cannot be higher than 55°C. The pressure test lasts about 5 minutes and can be run at earliest 10 minutes after closing light output (shutter closed) of the fixture. The pressure test can be repeated at earliest 2 minutes after last pressure test.

The screenshot shows the ROBE Personality interface with the Pressure test section highlighted by a red box. The section contains a green button labeled "Start test".

Examples of pressure test messages:

Pressure test is 10 minutes delayed due to fixture cooling

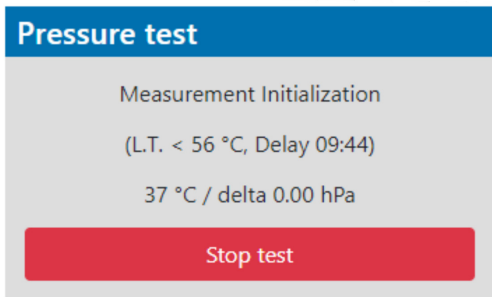

Pressure test is running

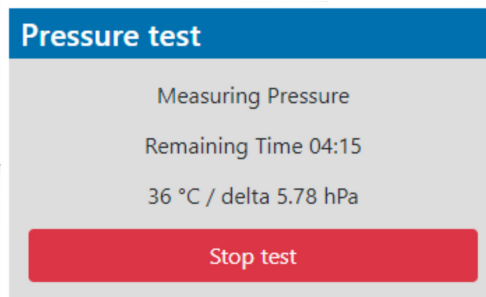

Pressure test passed

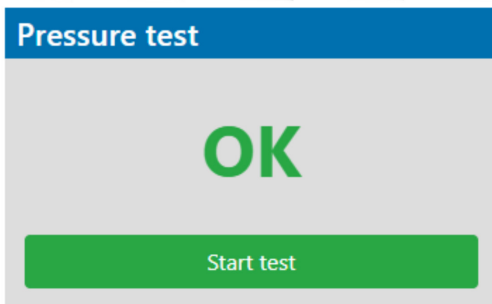

Pressure test failed

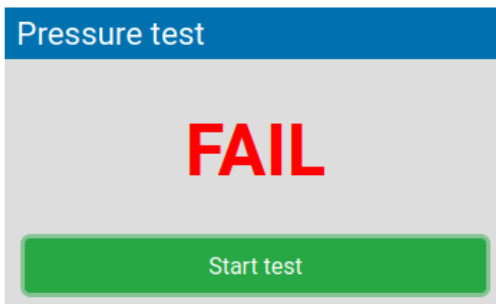

The **Logs screen** displays operating information of the fixture which have been saved.

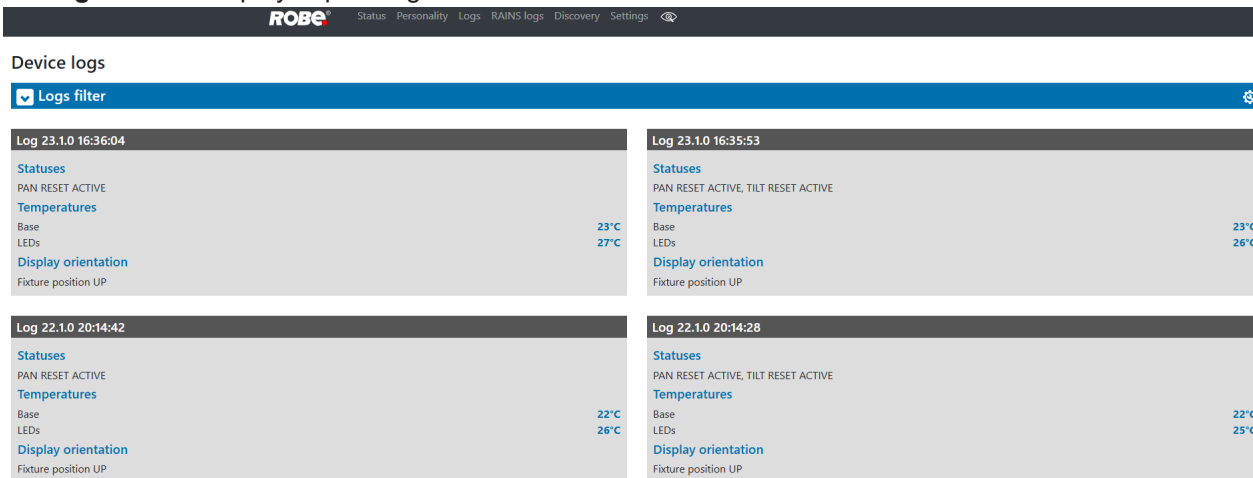

The icon  offers you two options:

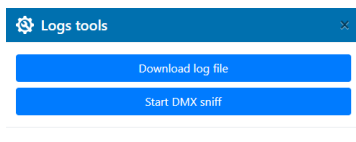

"Download log file" - the option allows you to download the log file to computer, name of the log file is: file-abcd.log, where abcd is a fixture ID (e.g. file-015e.log).

"Start DMX sniff" - the option starts saving coming DMX values to the file, the file name is DMX_sniffer.log).

The option **Logs filter** allows you to select desired group of recorded errors and recorded operating values.

Device logs

Logs filter

Groups
 Mechanical Errors System Errors Statuses Display Orientation Temperatures

Temperatures
 Base: [] °C

Start date/time
 Date: dd. mm. yyyy Time: --:--:--

Sorting
 Sorting: descending

[Apply filter](#) [Clear filter](#)

Log 23.1.0 16:36:04
Statuses
 PAN RESET ACTIVE
Temperatures
 Base: 23°C
 LEDs: 27°C
Display orientation
 Fixture position UP

Log 23.1.0 16:35:53
Statuses
 PAN RESET ACTIVE, TILT RESET ACTIVE
Temperatures
 Base: 23°C
 LEDs: 26°C
Display orientation
 Fixture position UP

Log 22.1.0 20:14:42
Statuses

Log 22.1.0 20:14:28
Statuses

If the option "all must pass" is checked, only logs which contain all selected errors will be displayed.
 Menu "Sorting filter pass" --> option "single groups" means that logs which contain at least one selected error will be displayed.
 Menu "Sorting, filter pass" option "all groups" means that logs which contain all selected error will be displayed.

The **screen RAINS Logs** offers you a list of physical values recorded by sensors inside the head.

RAINS logs

Sensors [Pressure measurements](#)

Logs filter [Download log file](#)

Date / Time	Temperature [°C]	Relative humidity [%]	Pressure [hPa]
23.1.0 21:57:43	43	11.5	981
23.1.0 21:57:13	42	11.5	981
23.1.0 21:56:43	42	11.5	981
23.1.0 21:56:13	43	11.5	981
23.1.0 21:55:43	42	11.5	981
23.1.0 21:55:12	43	11.5	981
23.1.0 21:54:41	43	11.5	981
23.1.0 21:54:11	43	11.5	981
23.1.0 21:53:41	43	11.5	981
23.1.0 21:53:11	43	11.5	981
23.1.0 21:52:41	43	11.5	981

You can select range of temperature, humidity and pressure in desired time interval.

ROBE® Status Personality Logs RAINS logs Discovery Settings

RAINS logs

Sensors Pressure measurements

Logs filter

Start date dd. mm. rrrr End date dd. mm. rrrr

Temperature - °C

Relative humidity - %

Pressure - hPa

Apply filter Clear filter

Download log file

Date / Time	Temperature [°C]	Relative humidity [%]	Pressure [hPa]
23.1.0 21:57:43	43	11.5	981
23.1.0 21:57:13	42	11.5	981
23.1.0 21:56:43	42	11.5	981
23.1.0 21:56:13	43	11.5	981
23.1.0 21:55:43	42	11.5	981
23.1.0 21:55:12	43	11.5	981
23.1.0 21:54:41	43	11.5	981

Tab Pressure measurements shows history of pressure tests.

ROBE® Status Personality Logs Sensors Discovery Settings

Sensors

Sensors logs Pressure measurements

Download measurements file

Date / Time	Temperature [°C]	Relative humidity [%]	Pressure [hPa]	Pressure difference [hPa]	Duration [ms]	Result
11.1.2023 14:59:17	47	8.5	991	7.03	03:26	OK
10.1.2023 09:45:47	27	11.0	988	7.28	02:32	OK

If you have two and more fixtures, the **Discovery screen** allows you to show all connected fixtures in network. Click on the blue button **Discover** and fixtures connected in the network will be displayed.

ROBE® Status Personality Logs RAINS logs Discovery Settings

Discovery

Move devices with warning to top





Columns selection (max. 7 items)

DMX address DMX preset RDM UID IP address Head temperature [°C] Relative humidity [%] RAINS (max wet) Last pressure test Device status



Discover (4) Apply selection

Device	DMX address	DMX preset	RDM UID	IP address	RAINS (max wet)	Device status
Ariannie6	1	Mode 3 (43 channels)	52:53:01:66:00:10	2.249.212.16		active
iBolt	1	Mode 1 (37 channels)	52:53:01:38:02:b7	2.248.18.183		active
iPainte	1	Mode 2 (45 channels)	52:53:01:35:00:5d	2.247.196.93		active
iSpiderX	1	Mode 1 (49 channels)	52:53:01:38:00:00	2.247.72.0		active

The background colour in the device row denotes state of the fixture:





-  indicates "server fixture"(fixture of which IP address you have written to your WEB browser).
-  indicates fixture ready for operation.
-  indicates fixture which does not communicate with computer or "server fixture".
-  indicates fixture with error messages.

If the option Move devices with warning to top is checked, fixtures with some error will be displayed on the top of fixture list.

The option Columns selection allows you to check desired items which will be displayed in columns. Max. 6 items can be selected. After checking desired items, click on the blue button Apply selection to activate selection. Icons   allows you to order values in the column in descending or ascending order.

Note: The values of the fixture in the first blue row ("server fixture") will not be included into ordering.

Example.

Device	DMX address	RDM UID	IP address	RAINS (max wet)	Last pressure test	Device status
iForte - iForte 3	1	52:53:01:2c:00:1a	2.247.136.26		11.1.2023 14:59:17 - OK	ready
iForte - iForte 4	1	52:53:01:2c:00:24	2.247.136.36		11.1.2023 15:12:47 - OK	ready
iForte - iForte 1	1	52:53:01:2c:00:13	2.247.136.19		13.1.2023 14:33:41 - OK	ready
iForte - iForte 8	1	52:53:01:2c:00:0b	2.247.136.11		11.1.2023 14:13:54 - Fail	ready

Item **ready** in the column Device status does not assess state of desiccants or result of pressure test!

The **screen Settings** allows you to change password to REAP.

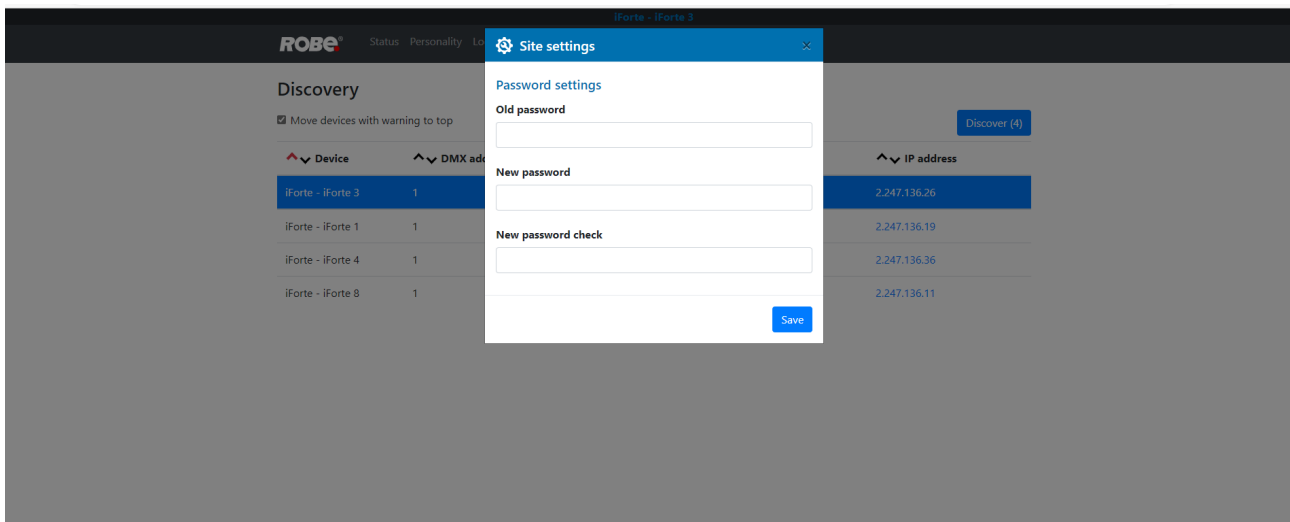

The icon  serves for identification of the fixture in a group of fixtures. After clicking on the icon, the fixture's head will start to move.

18. Technical Specifications

Electrical

Power supply:.....electronic auto-ranging
Input voltage range:..... supply 100-240V, 50-60Hz
Fuse:.....T 12 A/250V
Max. inrush current.....50A @ 240 VAC, 25 °C ambient, cold start
Max. power consumption950W (power factor= 0.97)

Optical system

Light source: 19 RGBL LED multichips
RGBL or CMY colour mixing
Three control zones of LEDs
LED life expectancy: min. 50.000 hours
Typical lumen maintenance: L70/B50 @ 50.000 hours

Virtual colour wheel

66 preset colours
CTC range: 1800K-10000K
Halogen lamp effect at whites 2700K - 4200K
Rainbow effect with in both directions with variable speed

Zoom

Linear motorized zoom
Zoom range: 3.8° - 60°

Strobe

Strobe effect with variable speed (0.3 - 20Hz)

Dimmer

Smooth dimmer from 0 - 100 %

Control

Setting & Addressing: ROBE Navigation System 3 (RNS3)
Gravitation sensor for auto screen positioning
Battery backup of the touch screen
Readout fixture and LED module usage, receiving DMX values, temperatures, etc
Built-in analyzer for easy fault finding, error messages
Individual pixel control of each LED
REAP™ - Robe Ethernet Access Portal
RAINS™ - Robe Automatic Ingress Neutralization System
Supported protocols: USITT DMX 512, RDM, ArtNet, MANet, MANet2, sACN
Support of RDM (Remote Device Management)
4 DMX modes (22, 27, 43, 50 control channels)

Wireless DMX/RDM module (type RW 001)

Supported protocols: full RDM support, CRMX , W-DMX™ G2, G3,G4 and G4S
Operational frequency range: 2402-2480 MHz
Output power: 100 mW
Receiver sensitivity (0.1% BER): -93 dBm
Crystal Clock Frequency : 16.0 MHz

Pan/Tilt

Pan movement range 540°
Tilt movement range 228°
16 bit movement resolution
Pan/Tilt electronic motion stabilizer
Automatic Pan/Tilt position correction

Remotely controllable speed of pan/tilt movement for easy programming
Pan/tilt-lock mechanism

Max. number of fixtures in Ethernet IN/Out line

8

Battery

Size: AA (R6)
Type: IFR 1450, 600mA/3.2V

Connection

DMX data In/Out: 2 x IP65 Locking 5-pin XLR connector Seetronic
AC power In: IP65 power connector Seetronic
Ethernet In/Out: 2 x IP65 RJ45 connector Seetronic

Rigging

Mounting points: 2 pairs of 1/4-turn locks
Mounting horizontally or vertically via two Omega brackets

Temperatures

Maximum ambient temperature: +50° C
Minimum ambient temperature: -50° C
Maximum housing temperature: 75° C

Minimum distances

Min. distance from flammable surfaces: 0.5 m
Min. distance to lighted object: 1 m

Total heat dissipation

Max. 2430 BTU/hr

Ingress protection

IP65

Weight

18 kg (39.7 lbs)

Dimensions (mm)

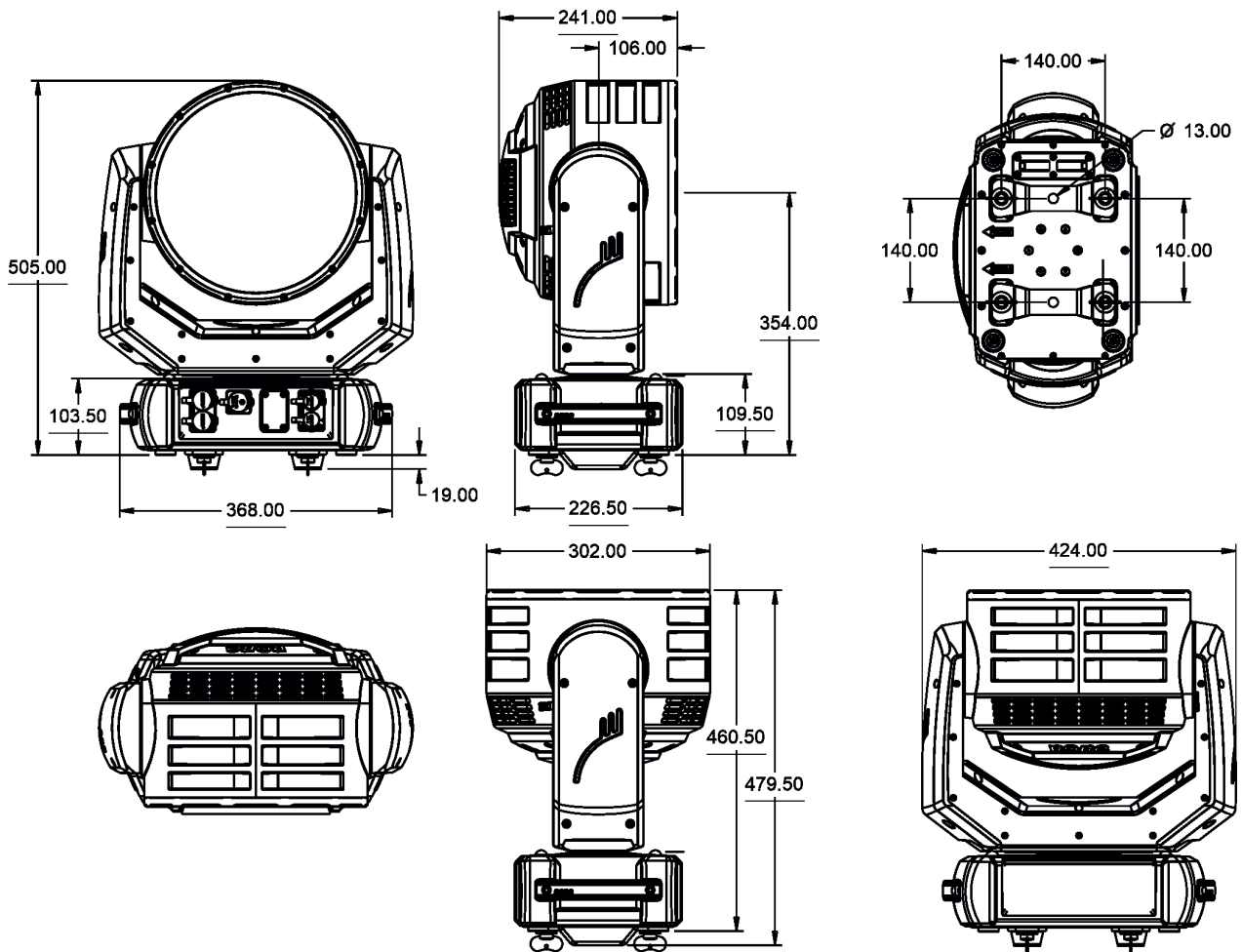

Accessories

- 1 x Omega adaptor CL-regular 2 pcs in box (P/N 10980033)
- 1 x user manual

Optional accessories

- Doughty Trigger Clamp (P/N 17030386)
- Safety wire 36 kg (P/N 99011963)

19. ChangeLog

This section summarizes changes in the user manual.

Version of the manual	Date of issue	Description of changes

March 25, 2026

Copyright © 2025-2026 Robe Lighting - All rights reserved

All Specifications subject to change without notice

Made in CZECH REPUBLIC by ROBE LIGHTING s.r.o. Palackeho 416/20 CZ 75701 Valasske Mezirici

UK
CA

EAC

DMX protocol

Robin Arianne 6™ - DMX protocol

Version: 1.8

Mode 1-Compatible mode, Mode 2- Pattern mode, Mode 3- Full mode, Mode 4-ScreenPix mode

Quick overview of default DMX values for each channel and mode

Mode/channel				Default DMX value				Note	Function
M.1	M.2	M.3	M.4	M. 1	M.2	M.3	M.4		
1	1	1	1	128	128	128	128		Pan (8 bit)
2	2	2	2	0	0	0	0		Pan fine (16 bit)
3	3	3	3	128	128	128	128		Tilt (8 bit)
4	4	4	4	0	0	0	0		Tilt fine (16 bit)
5	5	5	5	0	0	0	0		Pan/Tilt speed, Pan/Tilt time
6	6	6	6	0	0	0	0		Power/Special functions
7	7	7	7	0	0	0	0		Virtual colour wheel
16	8	8	8	0	0	0	0		CTC
17	9	9	9	45	45	0	0		Colour mix control
18	10	10	10	128	128	128	128		Zoom(8 bit)
19	11	11	11	0	0	0	0		Zoom fine (16 bit)
20	12	12	12	32	32	32	32		Shutter/ strobe
21	13	13	13	0	0	0	0		Dimmer intensity (8 bit)
22	14	14	14	0	0	0	0		Dimmer intensity fine (16 bit)
8	15	*	*	255/0	255/0	*	*	1	Red/Cyan (8 bit)- all zones
9	16	*	*	255/0	255/0	*	*	1	Red/Cyan fine (16 bit)-all zones
10	17	*	*	255/0	255/0	*	*	1	Green/Magenta (8 bit)-all zones
11	18	*	*	255/0	255/0	*	*	1	Green/Magenta fine (16 bit)-all zones
12	19	*	*	255/0	255/0	*	*	1	Blue/Yellow (8 bit)-all zones
13	20	*	*	255/0	255/0	*	*	1	Blue/Yellow fine (16 bit) -all zones
14	21	*	*	255/0	255/0	*	*	1	Lime (8 bit)- all zones
15	22	*	*	255/0	255/0	*	*	1	Lime fine (16 bit)-all zones
*	23	15	15	*	128	128	128		Green correction -all zones
*	24	16	16	*	10	10	10		LED frequency selection
*	25	17	17	*	0	0	0		LED frequency fine adjusting
*	26	18	18	*	0	0	0		Pattern selection
*	27	19	19	*	128	128	128		Pattern movement speed and direction
*	*	20	20	*	*	255/0	255/0	1	Red/Cyan (8 bit)- Zone 1
*	*	21	21	*	*	255/0	255/0	1	Red/Cyan fine (16 bit)-zone 1
*	*	22	22	*	*	255/0	255/0	1	Green/Magenta (8 bit)-zone 1
*	*	23	23	*	*	255/0	255/0	1	Green/Magenta fine (16 bit)-zone 1
*	*	24	24	*	*	255/0	255/0	1	Blue/Yellow (8 bit)-zone 1
*	*	25	25	*	*	255/0	255/0	1	Blue/Yellow fine (16 bit) - zone 1
*	*	26	26	*	*	255/0	255/0	1	Lime (8 bit)- zone 1
*	*	27	27	*	*	255/0	255/0	1	Lime fine (16 bit)-zone 1
*	*	28	28	*	*	255/0	255/0	1	Red/Cyan (8 bit)- Zone 2
*	*	29	29	*	*	255/0	255/0	1	Red/Cyan fine (16 bit)-zone 2
*	*	30	30	*	*	255/0	255/0	1	Green/Magenta (8 bit)-zone 2
*	*	31	31	*	*	255/0	255/0	1	Green/Magenta fine (16 bit)-zone 2
*	*	32	32	*	*	255/0	255/0	1	Blue/Yellow (8 bit)-zone 2
*	*	33	33	*	*	255/0	255/0	1	Blue/Yellow fine (16 bit) - zone 2
*	*	34	34	*	*	255/0	255/0	1	Lime (8 bit)- zone 2
*	*	35	35	*	*	255/0	255/0	1	Lime fine (16 bit)-zone 2

DMX protocol

Mode/channel				Default DMX value				Note	Function
M.1	M.2	M.3	M.4	M.1	M.2	M.3	M.4		
*	*	36	36	*	*	255/0	255/0	1	Red/Cyan (8 bit)- Zone 3
*	*	37	37	*	*	255/0	255/0	1	Red/Cyan fine (16 bit)-zone 3
*	*	38	38	*	*	255/0	255/0	1	Green/Magenta (8 bit)-zone 3
*	*	39	39	*	*	255/0	255/0	1	Green/Magenta fine (16 bit)-zone 3
*	*	40	40	*	*	255/0	255/0	1	Blue/Yellow (8 bit)-zone 3
*	*	41	41	*	*	255/0	255/0	1	Blue/Yellow fine (16 bit) - zone 3
*	*	42	42	*	*	255/0	255/0	1	Lime (8 bit)- zone 3
*	*	43	43	*	*	255/0	255/0	1	Lime fine (16 bit)-zone 3
*	*	*	44	*	*	*	255		ScreenPix Red - background
*	*	*	45	*	*	*	255		ScreenPix Green - background
*	*	*	46	*	*	*	255		ScreenPix Blue - background
*	*	*	47	*	*	*	0		ScreenPix Effect selection
*	*	*	48	*	*	*	128		Effect movement speed and direction
*	*	*	49	*	*	*	1		ScreenPix Effect colour selection
*	*	*	50	*	*	*	127		ScreenPix Dimmer and Shutter - background

Note 1. Default value: 255 - RGBL mode, 0-CMY mode

Order of zones

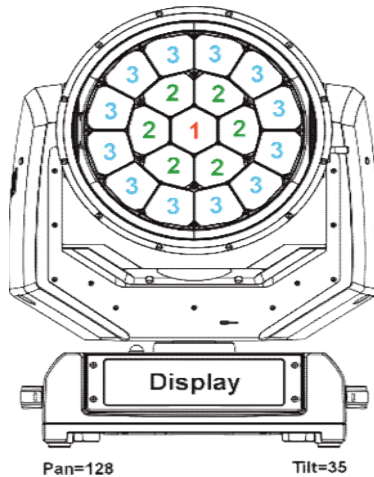

Robin Arianne 6™ - DMX protocol

Version: 1.8

Mode 1- Compatible mode, Mode 2- Pattern mode, Mode 3- Full mode, Mode 4- ScreenPix mode

Mode/channel				DMX Value	Function	Type of control
1	2	3	4			
1	1	1	1	0 - 255	Pan (8 bit) Pan movement by 540°	proportional
2	2	2	2	0 - 255	Pan Fine (16 bit) Fine control of pan movement	proportional
3	3	3	3	0 - 255	Tilt (8 bit) Tilt movement by 220°	proportional
4	4	4	4	0 - 255	Tilt fine (16 bit) Fine control of tilt movement	proportional
5	5	5	5	0	Pan/Tilt speed , Pan/Tilt time Standard mode	step
				1	Max. Speed Mode	step
				2 - 255	Pan/Tilt speed mode Speed from max. to min.	proportional
				2 - 255	Pan/Tilt time mode Time from 0.2 s to 25.5 sec.	proportional
6	6	6	6	0-5	Power/Special functions Reserved	
					<i>To activate following functions, stop in DMX value for at least 3 s and shutter must be closed at least 3 sec. („Shutter,Strobe“ channel 12 must be at range: 0-31 DMX). Corresponding menu items are temporarily overridden (unless otherwise stated)</i>	
				6-7	Standby mode: On (fixture effects are deactivated, light output is closed)	step
				8-9	Standby mode: Off	step
				10-14	DMX input: Wired DMX	step
				15-19	DMX input: Wireless DMX *	step
				20-24	Graphic display: On	step
				25-29	Graphic display: Off	step
				30-34	Colour mixing mode: RGBL	step
				35-39	Colour mixing mode: CMY	step
				40-44	Pan/Tilt mode: Speed	step
				45-49	Pan/Tilt mode: Time	step
				50-54	Blackout while pan/tilt moving	step
				55-59	Disabled blackout while pan/tilt moving	step
				60-64	Dimmer curve: Square law	step
				65-69	Dimmer curve: Linear	step
				70-74	Fans mode: Auto	step
				75-79	Fans mode: High	step
				80-84	White point: On	step
				85-89	White point: Off	step
				90-91	Pressure test: On (fixture does not respond to DMX during the test except values 92-93 (Pressure test: Off))	step
				92-93	Pressure test: Off	step
				94-95	ScreenPix: On (Channels 44-50 are activated)	step

Mode/channel				DMX Value	Function	Type of control
1	2	3	4			
				96-97	ScreenPix: Off (channels 44-50 are deactivated)	step
				98-99	ScreenPix synchronization: On (ScreenPix utilizes zone colours if colours of zones 1/2/3 are the same)	step
				100-101	ScreenPix synchronization: Off	step
				102-103	High light output mode	step
				104-105	CRI light output mode	step
				106-125	Reserved	
				126-127	Parking position: On	step
				128-129	Parking position: Off	step
					<i>To activate following functions, stop in DMX value for at least 3 seconds. Corresponding menu items are temporarily overridden</i>	
				130-139	Fixture reset (except pan/tilt)	
				140-149	Pan/Tilt reset	step
				150-159	Zoom reset	step
				160-169	Total fixture reset	step
				170-171	Tungsten effect simulation (750W) On **	step
				172-173	Tungsten effect simulation (1000W) On **	step
				174-175	Tungsten effect simulation (1200W) On **	step
				176-177	Tungsten effect simulation (2000W) On **	step
				178-179	Tungsten effect simulation (2500W) On **	step
				180-181	Tungsten effect simulation Off	step
					<i>Green/Blue correction : 1. Activate the Green/Blue correction by the command "Green/Blue correction calibration". 2. Select desired colour temperature below and set green/blue correction using the "Green correction "channel and the "CTC" channel. 3. After setting corrections, use command "Save Green/Blue correction".</i>	
				182	Green/Blue correction calibration	
				183	Green/Blue correction - 1800K/High Intensity	step
				184	Green/Blue correction - 2700K/High Intensity	step
				185	Green/Blue correction - 3200K/High Intensity	step
				186	Green/Blue correction - 4200K/High Intensity	step
				187	Green/Blue correction - 5600K/High Intensity	step
				188	Green/Blue correction - 8000K/High Intensity	step
				189	Green/Blue correction - 10000K/High Intensity	step
				190	Green/Blue correction - 1800K/High CRI	step
				191	Green/Blue correction - 2700K/High CRI	step
				192	Green/Blue correction - 3200K/High CRI	step
				193	Green/Blue correction - 4200K/High CRI	step
				194	Green/Blue correction - 5600K/High CRI	step
				195	Green/Blue correction - 8000K/High CRI	step
				196	Green/Blue correction - 10000K/High CRI	step
				197	Save Green/Blue correction	step
				198-237	Reserved	
					<i>The following RoboSpot related commands are only applicable when the RoboSpot is connected:</i>	
				238-239	RoboSpot enabled	step
				240-241	RoboSpot disabled - except handle faders and pan/tilt	step

Mode/channel				DMX Value	Function	Type of control
1	2	3	4			
				242-243	RoboSpot fully disabled	step
				244	Disabled "Quiet mode"	step
				245-255	Quiet mode - fan noise control from min. to max.	proportional
7	7	7	7		Virtual colour wheel -all zones	
				0	No function	step
				1-2	Filter 4 (Medium Bastard Amber)	step
				3-4	Filter 25 (Sunset Red)	step
				5-6	Filter 19 (Fire)	step
				7-8	Filter 26 (Bright Red)	step
				9-10	Filter 58 (Lavender)	step
				11-12	Filter 68 (Sky Blue)	step
				13-14	Filter 36 (Medium Pink)	step
				15-16	Filter 89 (Moss Green)	step
				17-18	Filter 88 (Lime Green)	step
				19-20	Filter 90 (Dark Yellow Green)	step
				21-22	Filter 49 (Medium Purple)	step
				23-24	Filter 52 (Light Lavender)	step
				25-26	Filter 102 (Light Amber)	step
				27-28	Filter 103 (Straw)	step
				29-30	Filter 140 (Summer Blue)	step
				31-32	Filter 124 (Dark Green)	step
				33-34	Filter 106 (Primary Red)	step
				35-36	Filter 111 (Dark Pink)	step
				37-38	Filter 115 (Peacock Blue)	step
				39-40	Filter 126 (Mauve)	step
				41-42	Filter 117 (Steel Blue)	step
				43-44	Filter 118 (Light Blue)	step
				45-46	Filter 122 (Fern Green)	step
				47-48	Filter 182 (Light Red)	step
				49-50	Filter 121 (Filter Green)	step
				51-52	Filter 128 (Bright Pink)	step
				53-54	Filter 131 (Marine Blue)	step
				55-56	Filter 132 (Medium Blue)	step
				57-58	Filter 134 (Golden Amber)	step
				59-60	Filter 135 (Deep Golden Amber)	step
				61-62	Filter 136 (Pale Lavender)	step
				63-64	Filter 137 (Special Lavender)	step
				65-66	Filter 138 (Pale Green)	step
				67-68	Filter 798 (Chrysalis Pink)	step
				69-70	Filter 141 (Bright Blue)	step
				71-72	Filter 147 (Apricot)	step
				73-74	Filter 148 (Bright Rose)	step
				75-76	Filter 152 (Pale Gold)	step
				77-78	Filter 154 (Pale Rose)	step
				79-80	Filter 157 (Pink)	step
				81-82	Filter 143 (Pale Navy Blue)	step
				83-84	Filter 162 (Bastard Amber)	step
				85-86	Filter 164 (Flame Red)	step

Mode/channel				DMX Value	Function	Type of control
1	2	3	4			
				87-88	Filter 165 (Daylight Blue)	step
				89-90	Filter 169 (Lilac Tint)	step
				91-92	Filter 170 (Deep Lavender)	step
				93-94	Filter 172 (Lagoon Blue)	step
				95-96	Filter 194 (Surprise Pink)	step
				97-98	Filter 180 (Dark Lavender)	step
				99-100	Filter 181 (Congo Blue)	step
				101-102	Filter 197 (Alice Blue)	step
				103-104	Filter 201 (Full C.T. Blue)	step
				105-106	Filter 202 (Half C.T. Blue)	step
				107-108	Filter 203 (Quarter C.T. Blue)	step
				109-110	Filter 204 (Full C.T. Orange)	step
				111-112	Filter 219 (Fluorescent Green)	step
				113-114	Filter 206 (Quarter C.T. Orange)	step
				115-116	Filter 247 (Filter Minus Green)	step
				117-118	Filter 248 (Half Minus Green)	step
				119-120	Filter 281 (Three Quarter C.T. Blue)	step
				121-122	Filter 285 (Three Quarter C.T. Orange)	step
				123-124	Filter 352 (Glacier Blue)	step
				125-126	Filter 353 (Lighter Blue)	step
				127-128	Filter 507 (Madge)	step
				129-130	Filter 778 (Millennium Gold)	step
				131-132	Filter 793 (Vanity Fair)	step
				133-235	Raw DMX	proportional
				236-245	Rainbow effect (with fade time) from slow-> fast	proportional
				246-255	Rainbow effect (without fade time) from slow-> fast	proportional
16	8	8	8		CTC -all zones	
				0	10 000 K	step
				1-39	Colour temperature changing 9950 K ->8050 K (50 K /1 DMX)	proportional
				40	8000 K (40=Default)	step
				41-99	Colour temperature changing 7960 K ->5640 K (40 K/1 DMX)	proportional
				100	5600 K	step
				101-149	Colour temperature changing 5572 K ->4228 K (28 K/1 DMX)	proportional
				150	4200 K	step
				151-189	Colour temperature changing 4175 K ->3225 K (25 K/1 DMX)	proportional
				190	3200 K	step
				191-209	Colour temperature changing 3175 K ->2725 K (25K /1 DMX)	proportional
				210	2700K	step
				211-254	Colour temperature changing 2680 K ->1820 K (20K /1 DMX)	proportional
				255	1800K	step
17	9	9	9		Colour Mix control	
					<i>Defines relation between colour channels</i>	
					"Virtual" = Virtual Colour Wheel	
					"Colour mix" = Colour channels (RGLB/CMY/CTC) or zones	
				0-9	"Virtual" has priority over "Colour Mix"	step
				10-19	Maximum mode (highest values have priority)	step
				20-29	Minimum mode (lowest values have priority)	step
				30-39	Multiply mode (multiply "Virtual" and "Colour Mix")	step

Mode/channel				DMX Value	Function	Type of control
1	2	3	4			
				40-49	Addition mode ("Virtual" + "Colour mix")	step
				50-59	Subtraction mode ("Virtual" -" Colour mix")	step
				60-69	Inverted Subtraction mode ("Virtual" -" Colour mix")	step
				70-79	White Point Off	step
				80-128	Reserved	
				129	Virtual colors ("virtual" has priority)	step
				130-254	Crossfade (crossfade between "Virtual" and Colour mix)	proportional
				255	Colour channels ("Colour mix" has priority) or zones	step
18	10	10	10		Zoom (8 bit)	
				0-255	Zoom from max. to min.beam angle	proportional
19	11	11	11		Zoom - fine (16 bit)	
				0-255	Fine zooming	proportional
20	12	12	12		Shutter/ strobe	
				0 - 31	Shutter closed	step
				32 - 63	Shutter open	step
				64 - 95	Strobe-effect from slow to fast	proportional
				96 - 127	Shutter open	step
				128 - 143	Opening pulse in sequences from slow to fast	proportional
				144 - 159	Closing pulse in sequences from fast to slow	proportional
				160 - 191	Shutter open	step
				192 - 223	Random strobe-effect from slow to fast	proportional
				224 - 255	Shutter open	step
21	13	13	13		Dimmer intensity (8 bit)	
				0 - 255	Dimmer intensity from 0% to 100%	proportional
22	14	14	14		Dimmer intensity - fine (16 bit)	
				0 - 255	Fine dimming	proportional
8	15	*	*		Red/Cyan (8 bit)- all zones***	
				0 - 255	Colour saturation control - coarse 0-100%	proportional
9	16	*	*		Red/Cyan (16bit)- all zones***	
				0 - 255	Colour saturation control - fine	proportional
10	17	*	*		Green/Magenta (8 bit) -all zones***	
				0 - 255	Colour saturation control - coarse 0-100%	proportional
11	18	*	*		Green/Magenta (16bit) -all zones***	
				0 - 255	Colour saturation control - fine	proportional
12	19	*	*		Blue/Yellow (8 bit) -all zones***	
				0 - 255	Colour saturation control - coarse 0-100%	proportional
13	20	*	*		Blue/ Yellow (16bit) -all zones***	
				0 - 255	Colour saturation control - fine	proportional
14	21	*	*		Lime (8 bit) - all zones***	
					<i>If RGBL mode is selected:</i>	
				0-255	Colour saturation control - coarse 0-100%	proportional
					<i>If CMY mode is selected:</i>	
				0 - 255	No function	
15	22	*	*		Lime (16 bit) - all zones***	
				0 - 255	Colour saturation control - fine	proportional
*	23	15	15		Green correction - all zones	
				0	Uncorrected white	step
				1-127	Minus green --> uncorrected white	proportional

Mode/channel				DMX Value	Function	Type of control
1	2	3	4			
				128	Uncorrected white	step
				129-255	Uncorrected white --> Plus green	proportional
*	24	16	16		LED frequency selection	
					Factory display menu setting: 600Hz	
					<i>fine adjusted in 127 steps up/down around selected PWM frequency on</i>	
				0-4	PWM frequency from Display menu (fixture utilizes PWM frequency set in the display menu item Frequency Setup).	step
				5-9	300 Hz	step
				10-14	600 Hz	step
				15-19	1200 Hz	step
				20-24	2400 Hz	step
				25-29	High	step
				30-255	Reserved (fixture utilizes PWM frequency set in the display menu item Frequency Setup).	
*	25	17	17		LED frequency fine adjusting	
					Factory display menu setting: 600Hz	
					<i>Select desired PWM output frequency of LEDs on the channel above.</i>	
				0-1	Selected LED Frequency	step
				2	LED Frequency (step -126)	step
				3	LED Frequency (step -125)	step
				4	LED Frequency (step -124)	step
				:		
				125	LED Frequency (step -3)	step
				126	LED Frequency (step -2)	step
				127	LED Frequency (step -1)	step
				128	Selected LED Frequency	step
				129	LED Frequency (step +1)	step
				130	LED Frequency (step +2)	step
				131	LED Frequency (step +3)	step
				:		
				252	LED Frequency (step +124)	step
				253	LED Frequency (step +125)	step
				254	LED Frequency (step +126)	step
				255	Selected LED Frequency	step
*	26	18	18		Pattern effects	
				0	No pattern	step
				1	Center pulse = Red-> Green	step
				2	Center pulse = White-> Blue	step
				3	Center pulse = Lime-> Red	step
				4	Center pulse = Blue-> Green	step
				5	Center pulse = Lime-> White	step
				6	Center pulse = Red-> Blue	step
				7	Center pulse = Green-> White	step
				8	Center pulse= 1800K-> Red	step
				9	Center pulse= Yellow-> Lime	step
				10	Center pulse = White-> Red	step
				11	Center pulse = 10 000K-> 1800K	step
				12	Center pulse = Magenta-> Blue	step

Mode/channel				DMX Value	Function	Type of control
1	2	3	4			
				13	Center pulse = Yellow-> Red	step
				14	Center pulse = Cyan-> White	step
				15	Center pulse = Green-> Magenta	step
				16	Center pulse = 1800K-> Cyan	step
				17	Center pulse = Red-> Magenta	step
				18	Center pulse = Magenta-> 10 000K	step
				19	Center pulse = Cyan-> Lime	step
				20	Center pulse = Yellow-> Blue	step
				21	Inside out = Blackout-> Red-> Full Red	step
				22	Inside out = Blackout-> Green-> Full Green	step
				23	Inside out = Blackout-> Blue-> Full Blue	step
				24	Inside out = Blackout-> White-> Full White	step
				25	Inside out = Blackout->1800K-> Full 1800K	step
				26	Inside out = Blackout-> 10 000K-> Full 10 000K	step
				27	Inside out = Blackout-> Lime-> Full Lime	step
				28	Inside out = Blackout-> Cyan-> Full Cyan	step
				29	Inside out = Blackout-> Magenta-> Full Magenta	step
				30	Inside out = Blackout-> Yellow-> Yellow	step
				31	Colour Ring Shift = Red-> Blue = Magenta-> Cyan	step
				32	Colour Ring Shift = Cyan-> 1800K = White-> Cyan	step
				33	Colour Ring Shift = Green-> Red = Blue-> Lime	step
				34	Colour Ring Shift = 1800K-> Yellow = White-> 1800K	step
				35	Colour Ring Shift = Lime-> Yellow = Green-> Lime	step
				36	Trinity Changing Ring = Lime-> Yellow-> Green	step
				37	Trinity Changing Ring = Green-> White-> 1800K	step
				38	Trinity Changing Ring = Yellow-> Blue-> Red	step
				39	Trinity Changing Ring = Cyan-> Magenta-> Lime	step
				40	Trinity Changing Ring = Blue-> Lime-> Yellow	step
				41	Trinity Changing Ring = Red-> Blue-> Cyan	step
				42	Trinity Changing Ring = 1800K-> White-> Yellow	step
				43	Trinity Changing Ring = Blue-> White-> Red	step
				44	Trinity Changing Ring = Yellow-> Green-> Blue	step
				45	Trinity Changing Ring = Lime-> White-> 1800K	step
				46	Trinity Changing Ring = Green-> Lime-> Magenta	step
				47	Trinity Changing Ring = Red-> Cyan-> White	step
				48	Trinity Changing Ring = Cyan-> Magenta-> Yellow	step
				49	Trinity Changing Ring = Red-> Green-> Blue	step
				50	Trinity Changing Ring = Lime-> Cyan-> Red	step
				51	Groving Ring = Magenta-> White-> Blue	step
				52	Groving Ring = Yellow-> Red-> 1800K	step
				53	Groving Ring = Cyan-> Green-> White	step
				54	Groving Ring = Blue-> Magenta-> Lime	step
				55	Groving Ring = 1800K-> Cyan-> Red	step
				56	Groving Ring = Green-> Yellow-> Magenta	step
				57	Groving Ring = White-> Lime-> Cyan	step
				58	Groving Ring = Blue-> 1800K-> Yellow	step
				59	Groving Ring = Red-> White-> Green	step
				60	Groving Ring = Blue-> White->Lime	step

Mode/channel				DMX Value	Function	Type of control
1	2	3	4			
				61	Running Ring = Full Magenta-> Green	step
				62	Running Ring = Full Red-> Blue	step
				63	Running Ring = Full Cyan-> Magenta	step
				64	Running Ring = Full white-> Red	step
				65	Running Ring = Full Yellow-> Blue	step
				66	Running Ring = Full 1800K-> White	step
				67	Running Ring = Full Lime-> Green	step
				68	Running Ring = Full Blue-> White	step
				69	Running Ring= Full Magenta-> Red	step
				70	Running Ring = Full Red-> Yellow	step
				71	Color Loop ring = (R,B,G)->(M, C, L)->(White, 1800K, 10 000K)	step
				72	Color Loop ring = (G, Y, C)->(L, White, B)->(1800K, B, R)	step
				73	Color Loop ring = (B, C, M)->(R,Y,10 000K)->(G, L, White)	step
				74	Color Loop ring = (1800K, M, B)->(White, R, C)->(L, B, Y)	step
				75	Color Loop ring = (White, L, G)->(Y, 1800K, R)->(M, L, B)	step
				76-255	Raw DMX	proportional
*	27	19	19		Pattern movement speed and direction	
				0	No movement	step
				1-127	pattern movement from fast to slow, center to edge	proportional
				128	Pause - without movement	step
				129-255	Pattern movement from slow to fast, edge to center	proportional
*	*	20	20		Red/Cyan (8 bit) - zone 1***	
				0 - 255	Colour saturation control - coarse 0-100%	proportional
*	*	21	21		Red/Cyan (16bit)- zone 1***	
				0 - 255	Colour saturation control - fine	proportional
*	*	22	22		Green/Magenta (8 bit) - zone 1***	
				0 - 255	Colour saturation control - coarse 0-100%	proportional
*	*	23	23		Green/Magenta (16bit)- zone 1***	
				0 - 255	Colour saturation control - fine	proportional
*	*	24	24		Blue/Yellow (8 bit) - zone 1***	
				0 - 255	Colour saturation control - coarse 0-100%	proportional
*	*	25	25		Blue/Yellow (16bit)- zone 1***	
				0 - 255	Colour saturation control - fine	proportional
*	*	26	26		Lime (8 bit) - zone 1	
					<i>If RGBL mode is selected:</i>	
				0-255	Colour saturation control - coarse 0-100%	proportional
					<i>If CMY mode is selected:</i>	
				0 - 255	No function	
*	*	27	27		Lime (16 bit) - zone 1	
				0 - 255	Colour saturation control - fine	proportional
		28	28		Red/Cyan (8 bit) - zone 2***	
				0 - 255	Colour saturation control - coarse 0-100%	proportional
*	*	29	29		Red/Cyan (16bit)- zone 2***	
				0 - 255	Colour saturation control - fine	proportional
*	*	30	30		Green/Magenta (8 bit) - zone 2***	
				0 - 255	Colour saturation control - coarse 0-100%	proportional
*	*	31	31		Green/Magenta (16bit)- zone 2***	
				0 - 255	Colour saturation control - fine	proportional

Mode/channel				DMX Value	Function	Type of control
1	2	3	4			
*	*	32	32	0 - 255	Blue/Yellow (8 bit) - zone 2*** Colour saturation control - coarse 0-100%	proportional
*	*	33	33	0 - 255	Blue/Yellow (16bit)- zone 2*** Colour saturation control - fine	proportional
*	*	34	34	0-255	Lime (8 bit) - zone 2 <i>If RGBL mode is selected:</i> Colour saturation control - coarse 0-100%	proportional
				0 - 255	<i>If CMY mode is selected:</i> No function	
*	*	35	35	0 - 255	Lime (16 bit) - zone 2 Colour saturation control - fine	proportional
*	*	36	36	0 - 255	Red/Cyan (8 bit) - zone 3*** Colour saturation control - coarse 0-100%	proportional
*	*	37	37	0 - 255	Red/Cyan (16bit)- zone 3*** Colour saturation control - fine	proportional
*	*	38	38	0 - 255	Green/Magenta (8 bit) - zone 3*** Colour saturation control - coarse 0-100%	proportional
*	*	39	39	0 - 255	Green/Magenta (16bit)- zone 3*** Colour saturation control - fine	proportional
*	*	40	40	0 - 255	Blue/Yellow (8 bit) - zone 3*** Colour saturation control - coarse 0-100%	proportional
*	*	41	41	0 - 255	Blue/Yellow (16bit)- zone 3*** Colour saturation control - fine	proportional
*	*	42	42	0-255	Lime (8 bit) - zone 3 <i>If RGBL mode is selected:</i> Colour saturation control - coarse 0-100%	proportional
				0 - 255	<i>If CMY mode is selected:</i> No function	
*	*	43	43	0-255	Lime (16 bit) - zone 3 Colour saturation control - fine	proportional
*	*	*	44	0-255	ScreenPix Red - background Red display saturation control 0-100%	proportional
*	*	*	45	0-255	ScreenPix Green - background Green display saturation control 0-100%	proportional
*	*	*	46	0-255	ScreenPix Blue - background Blue display saturation control 0-100%	proportional
*	*	*	47	0	ScreenPix Effect selection No effect	step
				1	Effect 1	step
				2	Effect 2	step
				3	Effect 3	step
				4	Effect 4	step
				5	Effect 5	step
				6	Reserved	
				7	Effect 7	step
				8	Effect 8	step
				9	Reserved	
				10	Effect 10	step

Mode/channel				DMX Value	Function	Type of control
1	2	3	4			
				11	Reserved	
				12	Effect 12	step
				13	Reserved	
				14	Effect 14	step
				15	Effect 15	step
				16	Effect 16	step
				17	Effect 17	step
				18	Reserved	
				19	Effect 19	step
				20	Effect 20	step
				21	Effect 21	step
				22	Effect 22	step
				23	Effect 23	step
				24	Colour effect 24	step
				25	Colour effect 25	step
				26	Colour effect 26	step
				27	Colour effect 27	step
				28	Reserved	
				29	Colour effect 29	step
				30	Colour effect 30	step
				31	Colour effect 31	step
				32	Reserved	
				33	Colour effect 33	step
				34	Colour effect 34	step
				35	Colour effect 35	step
				36	Colour effect 36	step
				37-38	Reserved	
				39	Colour effect 39	step
				40	Colour effect 40	step
				41	Colour effect 41	step
				42	Colour effect 42	step
				43	Colour effect 43	step
				44	Colour effect 44	step
				45	Colour effect 45	step
				46	Colour effect 46	step
				47	Colour effect 47	step
				48	Colour effect 48	step
				49	Colour effect 49	step
				50	Colour effect 50	step
				51	Colour effect 51	step
				52	Colour effect 52	step
				53	Colour effect 53	step
				54	Colour effect 54	step
				55	Colour effect 55	step
				56	Colour effect 56	step
				57-255	Reserved	step
*	*	*	48		Effect movement speed and direction	
				0	No movement	step

Mode/channel				DMX Value	Function	Type of control
1	2	3	4			
				1-127	Effect movement from fast to slow, left to right	proportional
				128	Pause - without movement	step
				129-255	Effect movement from slow to fast, right to left	proportional
*	*	*	49		ScreenPix Effect colour selection	
				0	No colour (ScreenPix Effect light output closed)	step
				1-14	White	step
				15	Blue (Blue=full, Red+Green=0)	step
				16-54	Red=0, Green->up, Blue =full	proportional
				55	Light Blue (Red=0, Green=full, Blue =full)	step
				56 - 94	Red=0, Green=full, Blue->down	proportional
				95	Green (Red=0, Green=full, Blue =0)	step
				96 – 134	Red->up, Green=full, Blue=0	proportional
				135	Yellow (Red=full, Green=full, Blue=0)	step
				136 - 174	Red=full, Green->down, Blue=0	proportional
				175	Red(Red=full, Green=0, Blue=0)	step
				176 -214	Red=full, Green=0, Blue->up	proportional
				215	Magenta (Red=full, Green=0, Blue=full)	step
				216 - 254	Red -> down, Green=0, Blue=full	proportional
				255	Blue (Red=0, Green=0, Blue=full)	step
*	*	*	50		Screen Pix Dimmer and Shutter - background	
				0-127	Dimmer intensity from 0% to 100%	proportional
				128-159	Strobe-effect from slow to fast	proportional
				160-170	Shutter open	step
				171-186	Opening pulse in sequences from slow to fast	proportional
				187-202	Closing pulse in sequences from fast to slow	proportional
				203-213	Shutter open	step
				214-245	Random strobe-effect from slow to fast	proportional
				246-255	Shutter open	step
* function is active only 10 seconds after switching the fixture on						
** In the Tungsten effect simulation the Dimmer channel imitates behaviour of the halogen lamp during dimming						
*** Select RGB or CMY mixing mode on channel "Power/Special functions"						
Copyright © 2025-2026 Robe Lighting s.r.o. - All rights reserved						
All Specifications subject to change without notice						