

DMX protocol

Robin Arianne 2™ - DMX protocol

Version: 1.5

Mode 1-LedBeam compatible, Mode 2- Festival/TV, Mode 3- Full/ScreenPix

Quick overview of default DMX values for each channel and mode

Mode/channel			Default DMX value			Note	Function
M.1	M.2	M3	M. 1	M.2	M.3		
1	1	1	128	128	128		Pan (8 bit)
2	2	2	0	0	0		Pan fine (16 bit)
3	3	3	128	128	128		Tilt (8 bit)
4	4	4	0	0	0		Tilt fine (16 bit)
5	5	5	0	0	0		Pan/Tilt speed, Pan/Tilt time
6	6	6	0	0	0		Power/Special functions
7	7	7	0	0	0		Virtual colour wheel
8	8	8	255/0	255/0	255/0	1	Red/Cyan (8 bit)- all zones
9	9	9	255/0	255/0	255/0	1	Red/Cyan fine (16 bit)-all zones
10	10	10	255/0	255/0	255/0	1	Green/Magenta (8 bit)-all zones
11	11	11	255/0	255/0	255/0	1	Green/Magenta fine (16 bit)-all zones
12	12	12	255/0	255/0	255/0	1	Blue/Yellow (8 bit)-all zones
13	13	13	255/0	255/0	255/0	1	Blue/Yellow fine (16 bit) -all zones
14	14	14	255/0	255/0	255/0	1	Lime (8 bit)- all zones
15	15	15	255/0	255/0	255/0	1	Lime fine (16 bit)-all zones
16	16	16	40	40	40		CTC -all zones
17	17	17	45	45	45		Colour mix control
18	18	18	128	128	128		Zoom(8 bit)
19	19	19	0	0	0		Zoom fine (16 bit)
20	20	20	32	32	32		Shutter/ strobe-all zones
21	21	21	0	0	0		Dimmer intensity (8 bit)-all zones
22	22	22	0	0	0		Dimmer intensity fine (16 bit)-all zones
*	23	23	*	128	128		Green correction -all zones
*	24	24	*	10	10		LED frequency selection
*	25	25	*	0	0		LED frequency fine adjusting
*	26	26	*	0	0		Pattern effects selection
*	27	27	*	64	64		Pattern movement speed and direction
*	*	28	*	*	255/0	1	Red/Cyan (8 bit)- Zone 1
*	*	29	*	*	255/0	1	Red/Cyan fine (16 bit)-zone 1
*	*	30	*	*	255/0	1	Green/Magenta (8 bit)-zone 1
*	*	31	*	*	255/0	1	Green/Magenta fine (16 bit)-zone 1
*	*	32	*	*	255/0	1	Blue/Yellow (8 bit)-zone 1
*	*	33	*	*	255/0	1	Blue/Yellow fine (16 bit) - zone 1
*	*	34	*	*	255/0	1	Lime (8 bit)- zone 1
*	*	35	*	*	255/0	1	Lime fine (16 bit)-zone 1
*	*	36	*	*	255/0	1	Red/Cyan (8 bit)- Zone 2
*	*	37	*	*	255/0	1	Red/Cyan fine (16 bit)-zone 2
*	*	38	*	*	255/0	1	Green/Magenta (8 bit)-zone 2
*	*	39	*	*	255/0	1	Green/Magenta fine (16 bit)-zone 2
*	*	40	*	*	255/0	1	Blue/Yellow (8 bit)-zone 2
*	*	41	*	*	255/0	1	Blue/Yellow fine (16 bit) - zone 2
*	*	42	*	*	255/0	1	Lime (8 bit)- zone 2
*	*	43	*	*	255/0	1	Lime fine (16 bit)-zone 2

DMX protocol

Mode/channel			Default DMX value			Note	Function
M.1	M.2	M3	M. 1	M.2	M.3		
*	*	44	*	*	255		ScreenPix Red - background
*	*	45	*	*	255		ScreenPix Green - background
*	*	46	*	*	255		ScreenPix Blue - background
*	*	47	*	*	0		ScreenPix Effect selection
*	*	48	*	*	128		Effect movement speed and direction
*	*	49	*	*	1		ScreenPix Effect colour selection
*	*	50	*	*	127		ScreenPix Dimmer and Shutter - background

Note 1. Default value: 255 - RGBL mode, 0-CMY mode

Order of zones

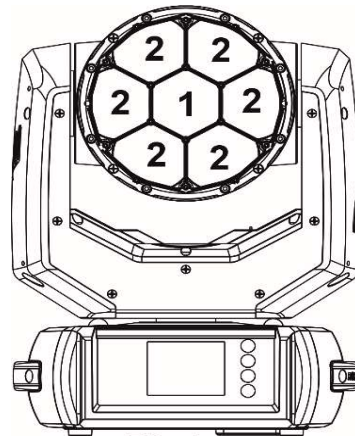

Pan=128 **Display** Tilt=35

Robin Arianne 2™ - DMX protocol

Version: 1.5

Mode 1-LedBeam compatible, Mode 2- Festival/TV, Mode 3- Full/ScreenPix

Mode/channel			DMX Value	Function	Type of control
1	2	3			
1	1	1		Pan (8 bit)	
			0 - 255	Pan movement by 540°	proportional
2	2	2		Pan Fine (16 bit)	
			0 - 255	Fine control of pan movement	proportional
3	3	3		Tilt (8 bit)	
			0 - 255	Tilt movement by 228°	proportional
4	4	4		Tilt fine (16 bit)	
			0 - 255	Fine control of tilt movement	proportional
5	5	5		Pan/Tilt speed , Pan/Tilt time	
			0	Standard mode	step
			1	Max. Speed Mode	step
				Pan/Tilt speed mode	
			2 - 255	Speed from max. to min.	proportional
				Pan/Tilt time mode	
			2 - 255	Time from 0.2 s to 25.5 sec.	proportional
6	6	6		Power/Special functions	
			0 -5	Reserved	
				<i>To activate following functions, stop in DMX value for at least 3 s and shutter must be closed at least 3 sec. („Shutter,Strobe“ channel 20 must be at range: 0-31 DMX). Corresponding menu items are temporarily overridden (unless otherwise stated)</i>	
			6-7	Standby mode: On (fixture effects are deactivated, light output is closed)	step
			8-9	Standby mode: Off	step
			10-14	DMX input: Wired DMX	step
			15-19	DMX input: Wireless DMX *	step
			20-24	Graphic display: On	step
			25-29	Graphic display: Off	step
			30-34	Colour mixing mode: RGBL	step
			35-39	Colour mixing mode: CMY	step
			40-44	Pan/Tilt mode: Speed	step
			45-49	Pan/Tilt mode: Time	step
			50-54	Blackout while pan/tilt moving	step
			55-59	Disabled blackout while pan/tilt moving	step
			60-64	Dimmer curve: Square law	step
			65-69	Dimmer curve: Linear	step
			70-74	Fans mode: Auto	step
			75-79	Fans mode: High	step
			80-84	White point: On	step
			85-89	White point: Off	step
			90-91	Pressure test: On (fixture does not respond to DMX during the test except values 92-93 (Pressure test: Off))	step
			92-93	Pressure test: Off	step
			94-95	ScreenPix: On (Channels 44-50 are activated)	step

Mode/channel			DMX Value	Function	Type of control
1	2	3			
			96-97	ScreenPix: Off (channels 44-50 are deactivated)	step
			98-99	ScreenPix synchronization: On (ScreenPix utilizes zone colours if colours of zones 1 and 2 are the same)	step
			100-101	ScreenPix synchronization: Off	step
			102-103	High light output mode	step
			104-105	CRI light output mode	step
			106-125	Reserved	
			126-127	Parking position: On	step
			128-129	Parking position: Off	step
				<i>To activate following functions, stop in DMX value for at least 3 seconds. Corresponding menu items are temporarily overridden</i>	
			130-139	Fixture reset (except pan/tilt)	
			140-149	Pan/Tilt reset	step
			150-159	Zoom reset	step
			160-169	Total fixture reset	step
			170-171	Tungsten effect simulation (750W) On **	step
			172-173	Tungsten effect simulation (1000W) On **	step
			174-175	Tungsten effect simulation (1200W) On **	step
			176-177	Tungsten effect simulation (2000W) On **	step
			178-179	Tungsten effect simulation (2500W) On **	step
			180-181	Tungsten effect simulation Off	step
				<i>Green/Blue correction : 1. Activate the Green/Blue correction by the command "Green/Blue correction calibration". 2. Select desired colour temperature below and set green/blue correction using the "Green correction" channel and the "CTC" channel. 3. After setting corrections, use command "Save Green/Blue correction".</i>	
			182	Green/Blue correction calibration	
			183	Green/Blue correction - 1800K/High Intensity	step
			184	Green/Blue correction - 2700K/High Intensity	step
			185	Green/Blue correction - 3200K/High Intensity	step
			186	Green/Blue correction - 4200K/High Intensity	step
			187	Green/Blue correction - 5600K/High Intensity	step
			188	Green/Blue correction - 8000K/High Intensity	step
			189	Green/Blue correction - 10000K/High Intensity	step
			190	Green/Blue correction - 1800K/High CRI	step
			191	Green/Blue correction - 2700K/High CRI	step
			192	Green/Blue correction - 3200K/High CRI	step
			193	Green/Blue correction - 4200K/High CRI	step
			194	Green/Blue correction - 5600K/High CRI	step
			195	Green/Blue correction - 8000K/High CRI	step
			196	Green/Blue correction - 10000K/High CRI	step
			197	Save Green/Blue correction	step
			198-237	Reserved	
				<i>The following RoboSpot related commands are only applicable when the RoboSpot is connected:</i>	
			238-239	RoboSpot enabled	step
			240-241	RoboSpot disabled - except handle faders and pan/tilt	step

Mode/channel			DMX Value	Function	Type of control
1	2	3			
			242-243	RoboSpot fully disabled	step
			244	Disabled "Quiet mode"	step
			245-255	Quiet mode - fan noise control from min. to max.	proportional
7	7	7		Virtual colour wheel -all zones	
			0	No function	step
			1-2	Filter 4 (Medium Bastard Amber)	step
			3-4	Filter 25 (Sunset Red)	step
			5-6	Filter 19 (Fire)	step
			7-8	Filter 26 (Bright Red)	step
			9-10	Filter 58 (Lavender)	step
			11-12	Filter 68 (Sky Blue)	step
			13-14	Filter 36 (Medium Pink)	step
			15-16	Filter 89 (Moss Green)	step
			17-18	Filter 88 (Lime Green)	step
			19-20	Filter 90 (Dark Yellow Green)	step
			21-22	Filter 49 (Medium Purple)	step
			23-24	Filter 52 (Light Lavender)	step
			25-26	Filter 102 (Light Amber)	step
			27-28	Filter 103 (Straw)	step
			29-30	Filter 140 (Summer Blue)	step
			31-32	Filter 124 (Dark Green)	step
			33-34	Filter 106 (Primary Red)	step
			35-36	Filter 111 (Dark Pink)	step
			37-38	Filter 115 (Peacock Blue)	step
			39-40	Filter 126 (Mauve)	step
			41-42	Filter 117 (Steel Blue)	step
			43-44	Filter 118 (Light Blue)	step
			45-46	Filter 122 (Fern Green)	step
			47-48	Filter 182 (Light Red)	step
			49-50	Filter 121 (Filter Green)	step
			51-52	Filter 128 (Bright Pink)	step
			53-54	Filter 131 (Marine Blue)	step
			55-56	Filter 132 (Medium Blue)	step
			57-58	Filter 134 (Golden Amber)	step
			59-60	Filter 135 (Deep Golden Amber)	step
			61-62	Filter 136 (Pale Lavender)	step
			63-64	Filter 137 (Special Lavender)	step
			65-66	Filter 138 (Pale Green)	step
			67-68	Filter 798 (Chrysalis Pink)	step
			69-70	Filter 141 (Bright Blue)	step
			71-72	Filter 147 (Apricot)	step
			73-74	Filter 148 (Bright Rose)	step
			75-76	Filter 152 (Pale Gold)	step
			77-78	Filter 154 (Pale Rose)	step
			79-80	Filter 157 (Pink)	step
			81-82	Filter 143 (Pale Navy Blue)	step
			83-84	Filter 162 (Bastard Amber)	step
			85-86	Filter 164 (Flame Red)	step

Mode/channel			DMX Value	Function	Type of control
1	2	3			
			87-88	Filter 165 (Daylight Blue)	step
			89-90	Filter 169 (Lilac Tint)	step
			91-92	Filter 170 (Deep Lavender)	step
			93-94	Filter 172 (Lagoon Blue)	step
			95-96	Filter 194 (Surprise Pink)	step
			97-98	Filter 180 (Dark Lavender)	step
			99-100	Filter 181 (Congo Blue)	step
			101-102	Filter 197 (Alice Blue)	step
			103-104	Filter 201 (Full C.T. Blue)	step
			105-106	Filter 202 (Half C.T. Blue)	step
			107-108	Filter 203 (Quarter C.T. Blue)	step
			109-110	Filter 204 (Full C.T. Orange)	step
			111-112	Filter 219 (Fluorescent Green)	step
			113-114	Filter 206 (Quarter C.T. Orange)	step
			115-116	Filter 247 (Filter Minus Green)	step
			117-118	Filter 248 (Half Minus Green)	step
			119-120	Filter 281 (Three Quarter C.T. Blue)	step
			121-122	Filter 285 (Three Quarter C.T. Orange)	step
			123-124	Filter 352 (Glacier Blue)	step
			125-126	Filter 353 (Lighter Blue)	step
			127-128	Filter 507 (Madge)	step
			129-130	Filter 778 (Millennium Gold)	step
			131-132	Filter 793 (Vanity Fair)	step
			133-235	Raw DMX	proportional
			236-245	Rainbow effect (with fade time) from slow-> fast	proportional
			246-255	Rainbow effect (without fade time) from slow-> fast	proportional
8	8	8		Red/Cyan (8 bit)- all zones***	
			0 - 255	Colour saturation control - coarse 0-100%	proportional
9	9	9		Red/Cyan (16bit)- all zones***	
			0 - 255	Colour saturation control - fine	proportional
10	10	10		Green/Magenta (8 bit) -all zones***	
			0 - 255	Colour saturation control - coarse 0-100%	proportional
11	11	11		Green/Magenta (16bit) -all zones***	
			0 - 255	Colour saturation control - fine	proportional
12	12	12		Blue/Yellow (8 bit) -all zones***	
			0 - 255	Colour saturation control - coarse 0-100%	proportional
13	13	13		Blue/ Yellow (16bit) -all zones***	
			0 - 255	Colour saturation control - fine	proportional
14	14	14		Lime (8 bit) - all zones***	
				<i>If RGBL mode is selected:</i>	
			0-255	Colour saturation control - coarse 0-100%	proportional
				<i>If CMY mode is selected:</i>	
			0 - 255	No function	
15	15	15		Lime (16 bit) - all zones***	
			0 - 255	Colour saturation control - fine	proportional
16	16	16		CTC -all zones	
			0	10 000 K	step
			1-39	Colour temperature changing 9950 K ->8050 K (50 K /1 DMX)	proportional

Mode/channel			DMX Value	Function	Type of control
1	2	3			
			40	8000 K (40=Default)	step
			41-99	Colour temperature changing 7960 K ->5640 K (40 K/1 DMX)	proportional
			100	5600 K	step
			101-149	Colour temperature changing 5572 K ->4228 K (28 K/1 DMX)	proportional
			150	4200 K	step
			151-189	Colour temperature changing 4175 K ->3225 K (25 K/1 DMX)	proportional
			190	3200 K	step
			191-209	Colour temperature changing 3175 K ->2725 K (25K /1 DMX)	proportional
			210	2700K	step
			211-254	Colour temperature changing 2680 K ->1820 K (20K /1 DMX)	proportional
			255	1800K	step
17	17	17		Colour Mix control	
				<i>Defines relation between colour channels</i>	
				"Global" = Global Colours (RGLB/CMYcolours, Virtual Colour Wheel, CTC)	
				"Pixel" = Zone colours (individual zones, zone patterns)	
			0-9	Global colours (Global has priority)	step
			10-19	Maximum mode (highest values have priority)	step
			20-29	Minimum mode (lowest values have priority)	step
			30-39	Multiply mode (multiply Global and Pixel)	step
			40-49	Addition mode (Global + Pixel)	step
			50-59	Subtraction mode (Global – Pixel)	step
			60-69	Inverted Subtraction mode (Pixel – Global)	step
			70-127	Raw DMX	proportional
			128	Global colours only (Global has priority)	step
			129-254	Crossfade (crossfade between Global and Pixel)	proportional
			255	Pixel has priority	step
18	18	18		Zoom (8 bit)	
			0-255	Zoom from max. to min.beam angle	proportional
19	19	19		Zoom - fine (16 bit)	
			0-255	Fine zooming	proportional
20	20	20		Shutter/ strobe	
			0 - 31	Shutter closed	step
			32 - 63	Shutter open	step
			64 - 95	Strobe eEffect from slow to fast -all zones together	proportional
			96 - 127	Shutter open	step
			128 - 143	Opening pulse in sequences from slow to fast-all zones together	proportional
			144 - 159	Closing pulse in sequences from fast to slow-all zones together	proportional
			160 - 169	Shutter open	step
			170 - 191	Random strobe zones - each zone strobos random	proportional
			192 - 223	Random strobe effect from slow to fast-all zones together	proportional
			224 - 255	Shutter open	step
21	21	21		Dimmer intensity (8 bit)-all zones	
			0 - 255	Dimmer intensity from 0% to 100%	proportional
22	22	22		Dimmer intensity fine (16 bit)-all zones	
			0 - 255	Fine dimming	proportional
*	23	23		Green correction - all zones	
			0	Uncorrected white	step
			1-127	Minus green --> uncorrected white	proportional

Mode/channel			DMX Value	Function	Type of control
1	2	3			
			128	Uncorrected white	step
			129-255	Uncorrected white --> Plus green	proportional
*	24	24		LED frequency selection	
				Factory display menu setting: 600Hz	
				<i>fine adjusted in 127 steps up/down around selected PWM frequency on</i>	
			0-4	PWM frequency from Display menu (fixture utilizes PWM frequency set in the display menu item Frequency Setup).	step
			5-9	300 Hz	step
			10-14	600 Hz	step
			15-19	1200 Hz	step
			20-24	2400 Hz	step
			25-29	High	step
			30-255	Reserved (fixture utilizes PWM frequency set in the display menu item Frequency Setup).	
*	25	25		LED frequency fine adjusting	
				Factory display menu setting: 600Hz	
				<i>Select desired PWM output frequency of LEDs on the channel above.</i>	
			0-1	Selected LED Frequency	step
			2	LED Frequency (step -126)	step
			3	LED Frequency (step -125)	step
			4	LED Frequency (step -124)	step
			:		
			125	LED Frequency (step -3)	step
			126	LED Frequency (step -2)	step
			127	LED Frequency (step -1)	step
			128	Selected LED Frequency	step
			129	LED Frequency (step +1)	step
			130	LED Frequency (step +2)	step
			131	LED Frequency (step +3)	step
			:		
			252	LED Frequency (step +124)	step
			253	LED Frequency (step +125)	step
			254	LED Frequency (step +126)	step
			255	Selected LED Frequency	step
*	26	26		Pattern effects selection	
			0	No pattern	step
			1	Center pulse = Red-> Green	step
			2	Center pulse = White 5600K-> Blue	step
			3	Center pulse = Lime-> Red	step
			4	Center pulse = Blue-> Green	step
			5	Center pulse = Lime-> White 5600K	step
			6	Center pulse = Red-> Blue	step
			7	Center pulse = Green-> White 5600K	step
			8	Center pulse= White 1800K-> Red	step
			9	Center pulse= Yellow-> Lime	step
			10	Center pulse = White 5600K-> Red	step
			11	Center pulse = White 10 000K-> White 1800K	step
			12	Center pulse = Magenta-> Blue	step

Mode/channel			DMX Value	Function	Type of control
1	2	3			
			13	Center pulse = Yellow-> Red	step
			14	Center pulse = Cyan-> White 5600K	step
			15	Center pulse = Green-> Magenta	step
			16	Center pulse = White 1800K-> Cyan	step
			17	Center pulse = Red-> Magenta	step
			18	Center pulse = Magenta-> White 10 000K	step
			19	Center pulse = Cyan-> Lime	step
			20	Center pulse = Yellow-> Blue	step
			21	Inside out = Blackout-> Red-> Full Red	step
			22	Inside out = Blackout-> Green-> Full Green	step
			23	Inside out = Blackout-> Blue-> Full Blue	step
			24	Inside out = Blackout-> White 5600K-> Full White 5600K	step
			25	Inside out = Blackout->White 1800K-> Full White 1800K	step
			26	Inside out = Blackout-> White 10 000K-> Full White 10 000K	step
			27	Inside out = Blackout-> Lime-> Full Lime	step
			28	Inside out = Blackout-> Cyan-> Full Cyan	step
			29	Inside out = Blackout-> Magenta-> Full Magenta	step
			30	Inside out = Blackout-> Yellow-> Full Yellow	step
			31	Colour Ring Shift = Red-> Blue = Magenta-> Cyan	step
			32	Colour Ring Shift = Cyan-> White 1800K = White 5600K -> Cyan	step
			33	Colour Ring Shift = Green-> Red = Blue-> Lime	step
			34	Colour Ring Shift = White 1800K-> Yellow = White 5600K -> White 1800K	step
			35	Colour Ring Shift = Lime-> Yellow = Green-> Lime	step
			36-255	Raw DMX	proportional
*	27	27		Pattern movement speed and direction	
			0	No movement	step
				<i>Pattern movement without fade time</i>	
			1-63	Pattern movement from fast to slow, center to edge	proportional
			64	Pause - without movement	step
			65-127	Pattern movement from slow to fast, edge to center	proportional
			128	No movement	step
				<i>Pattern movement with fade time</i>	
			129-191	Pattern movement from fast to slow, center to edge	proportional
			192	Pause - without movement	step
			193-255	Pattern movement from slow to fast, edge to center	proportional
*	*	28		Red/Cyan (8 bit) - zone 1***	
			0 - 255	Colour saturation control - coarse 0-100%	proportional
*	*	29		Red/Cyan (16bit)- zone 1***	
			0 - 255	Colour saturation control - fine	proportional
*	*	30		Green/Magenta (8 bit) - zone 1***	
			0 - 255	Colour saturation control - coarse 0-100%	proportional
*	*	31		Green/Magenta (16bit)- zone 1***	
			0 - 255	Colour saturation control - fine	proportional
*	*	32		Blue/Yellow (8 bit) - zone 1***	
			0 - 255	Colour saturation control - coarse 0-100%	proportional
*	*	33		Blue/Yellow (16bit)- zone 1***	
			0 - 255	Colour saturation control - fine	proportional
*	*	34		Lime (8 bit) - zone 1	

Mode/channel			DMX Value	Function	Type of control
1	2	3			
				<i>If RGBL mode is selected:</i>	
			0-255	Colour saturation control - coarse 0-100%	proportional
				<i>If CMY mode is selected:</i>	
			0 - 255	No function	
*	*	35		Lime (16 bit) - zone 1	
			0 - 255	Colour saturation control - fine	proportional
		36		Red/Cyan (8 bit) - zone 2***	
			0 - 255	Colour saturation control - coarse 0-100%	proportional
*	*	37		Red/Cyan (16bit)- zone 2***	
			0 - 255	Colour saturation control - fine	proportional
*	*	38		Green/Magenta (8 bit) - zone 2***	
			0 - 255	Colour saturation control - coarse 0-100%	proportional
*	*	39		Green/Magenta (16bit)- zone 2***	
			0 - 255	Colour saturation control - fine	proportional
*	*	40		Blue/Yellow (8 bit) - zone 2***	
			0 - 255	Colour saturation control - coarse 0-100%	proportional
*	*	41		Blue/Yellow (16bit)- zone 2***	
			0 - 255	Colour saturation control - fine	proportional
*	*	42		Lime (8 bit) - zone 2	
				<i>If RGBL mode is selected:</i>	
			0-255	Colour saturation control - coarse 0-100%	proportional
				<i>If CMY mode is selected:</i>	
			0 - 255	No function	
*	*	43		Lime (16 bit) - zone 2	
			0 - 255	Colour saturation control - fine	proportional
*	*	44		ScreenPix Red - background	
			0-255	Red display saturation control 0-100%	proportional
*	*	45		ScreenPix Green - background	
			0-255	Green display saturation control 0-100%	proportional
*	*	46		ScreenPix Blue - background	
			0-255	Blue display saturation control 0-100%	proportional
*	*	47		ScreenPix Effect selection	
			0	No effect	step
			1	Effect 1	step
			2	Effect 2	step
			3	Effect 3	step
			4	Effect 4	step
			5	Effect 5	step
			6	Reserved	
			7	Effect 7	step
			8	Effect 8	step
			9	Reserved	
			10	Effect 10	step
			11	Reserved	
			12	Effect 12	step
			13	Reserved	
			14	Effect 14	step
			15	Effect 15	step

Mode/channel			DMX Value	Function	Type of control
1	2	3			
			16	Effect 16	step
			17	Effect 17	step
			18	Reserved	
			19	Effect 19	step
			20	Effect 20	step
			21	Effect 21	step
			22	Effect 22	step
			23	Effect 23	step
			24	Colour effect 24	step
			25	Colour effect 25	step
			26	Colour effect 26	step
			27	Colour effect 27	step
			28	Reserved	
			29	Colour effect 29	step
			30	Colour effect 30	step
			31	Colour effect 31	step
			32	Reserved	
			33	Colour effect 33	step
			34	Colour effect 34	step
			35	Colour effect 35	step
			36	Colour effect 36	step
			37-38	Reserved	
			39	Colour effect 39	step
			40	Colour effect 40	step
			41	Colour effect 41	step
			42	Colour effect 42	step
			43	Colour effect 43	step
			44	Colour effect 44	step
			45	Colour effect 45	step
			46	Colour effect 46	step
			47	Colour effect 47	step
			48	Colour effect 48	step
			49	Colour effect 49	step
			50	Colour effect 50	step
			51	Colour effect 51	step
			52	Colour effect 52	step
			53	Colour effect 53	step
			54	Colour effect 54	step
			55	Colour effect 55	step
			56	Colour effect 56	step
			57-255	Reserved	step
*	*	48		Effect movement speed and direction	
			0	No movement	step
			1-127	Effect movement from fast to slow, left to right	proportional
			128	Pause - without movement	step
			129-255	Effect movement from slow to fast, right to left	proportional
*	*	49		ScreenPix Effect colour selection	
			0	No colour (ScreenPix Effect light output closed)	step

Mode/channel			DMX Value	Function	Type of control
1	2	3			
			1-14	White	step
			15	Blue (Blue=full, Red+Green=0)	step
			16-54	Red=0, Green->up, Blue =full	proportional
			55	Light Blue (Red=0, Green=full, Blue =full)	step
			56 - 94	Red=0, Green=full, Blue->down	proportional
			95	Green (Red=0, Green=full, Blue =0)	step
			96 – 134	Red->up, Green=full, Blue=0	proportional
			135	Yellow (Red=full, Green=full, Blue=0)	step
			136 - 174	Red=full, Green->down, Blue=0	proportional
			175	Red(Red=full, Green=0, Blue=0)	step
			176 -214	Red=full, Green=0, Blue->up	proportional
			215	Magenta (Red=full, Green=0, Blue=full)	step
			216 - 254	Red -> down, Green=0, Blue=full	proportional
			255	Blue (Red=0, Green=0, Blue=full)	step
*	*	50		Screen Pix Dimmer and Shutter - background	
			0-127	Dimmer intensity from 0% to 100%	proportional
			128-159	Strobe-effect from slow to fast	proportional
			160-170	Shutter open	step
			171-186	Opening pulse in sequences from slow to fast	proportional
			187-202	Closing pulse in sequences from fast to slow	proportional
			203-213	Shutter open	step
			214-245	Random strobe-effect from slow to fast	proportional
			246-255	Shutter open	step
* function is active only 10 seconds after switching the fixture on					
** In the Tungsten effect simulation the Dimmer channel imitates behaviour of the halogen lamp during dimming					
*** Select RGB or CMY mixing mode on channel "Power/Special functions"					
Copyright © 2025-2026 Robe Lighting s.r.o. - All rights reserved					
All Specifications subject to change without notice					