

ADP-15



DATA SHEET

pag.1/5 V.12.11

- ▶ Class D Powered (bi-amplified)
- ▶ Integrated Digital Processing
- ▶ Internal temperature control
- ▶ Electronic protection
- ▶ FIR linear phase filtering
- ▶ Online monitoring available
- ▶ Two way active system



APPLICATION:

- Front fill/ Side fill/ reinforcement
- Smaller clubs/ discos
- Smaller Live stages/ events
- Compact voice reinforcement
- Portable installation

GENERAL DESCRIPTION:

The versatile ADP-15 is part of the ADP Self powered, DSP integrated Series. It has been designed to offer the utmost sound reinforcement reliability, incorporating the latest acoustical and electronic technology and delivering incredible, dynamic sound.

The ADP-15 is an extremely high power, two-way full range cabinet providing exceptional performance. For the low-mid frequencies it uses one 15" (100 mm voice coil) neodymium transducer with nomex cones and suspension. The high frequencies are looked after by a 1.4" compression driver with a 4" titanium diaphragm mounted on a 80° x 50° constant directivity rotatable horn.

The ADP-15 is powered with a total of 1500W of class D amplification, 750W for the low/mid frequencies and 750W for the high frequencies. Each cabinet has a DSP integrated for system protection and optimization. This DSP applies classical crossover and linear phase filtering. Other features include temperature sensor, fan speed control, Ethernet options and many more.

The compact ADP-15 has an unbeatable power to size ratio, there is no need for external amplification racks, is very light weight and is the ideal solution for portable or fixed sound reinforcement. A variety of rigging options make the ADP-15 easy to set-up in minimal time. To extend the low frequency response, the ADP-18S or ADP-12S sub bass cabinet can be used.

SPECIFICATIONS:

FREQUENCY RANGE	60Hz -20KHz
FREQUENCY RESPONSE	70Hz- 18KHz ± 3dB
COVERAGE	80° x 50° rotatable horn
MAX SPL	133 dB/ 136dB peak
TRANSDUCERS	LF/MF: 15" Custom Neodymium with Nomex Cone HF: 1.4" driver with 72" Titanium diaphragm and Neodymium magnet + constant directivity Horn
SHAPE	Trapezoidal
POWER AMPLIFIER	1500W Class D with Switching Power supply 750W Low/Mid + 750W High
DSP	Internal LYNX processor DSPB-22® with FIR filters
CABINET ADJUSTMENT	Back panel LCD screen
INTERNAL CONTROLS	Temperature sensor
SIGNAL CONNECTION	NEUTRIK connectors XLR Male Input XLR Female Loop Thru
CONTROL CONNECTIONS	USB (DSP programming), ETHERNET* (Online Monitoring System OMS®)
AC POWER	230v / 115v selectable. 50/60 Hz 5A
AC CONNECTIONS	16A NEUTRIK POWERCON with Looping Output
CONSTRUCTION	15 mm Premium Birch plywood
FINISH	High resistant water-based black paint
FRONT DESIGN	Black antirust steel grille
DIMENSIONS (H x W x D)	677 x 460 x 431 mm
WEIGHT	39 Kg (86 lbs)

* Ethernet connection is optional.

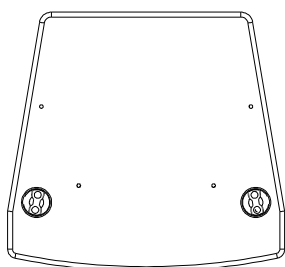
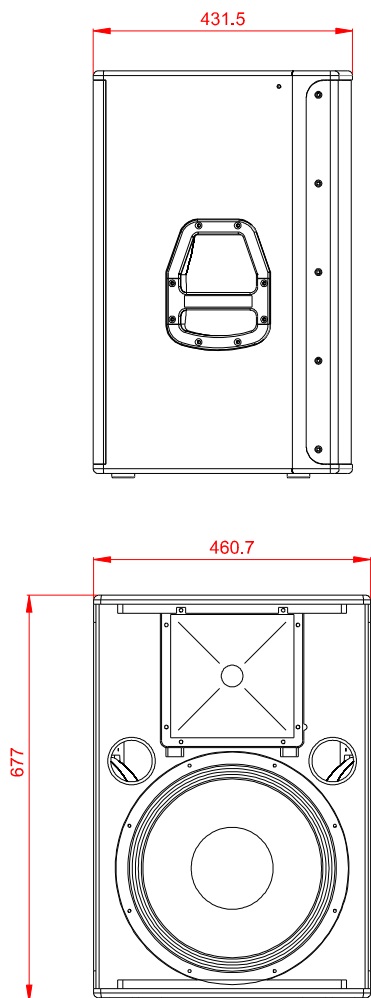

Dimensions in mm.

KEY FEATURES AND BENEFITS:

SELF POWERED

Bi-amplified Class D with switching power supply. Includes one 750W power module for the 15" transducer and one 750W power module for the HF driver. The amplification far exceeds the transducer need thus resulting in high output, high damping factor and extremely low levels of distortion.

DIGITAL PROCESSING & DOUBLE DYNAMICS

Latest generation 24bit/96Khz digital processor which optimizes the system components. It includes 2 channel processing electronics with functions for phase correction, driver protection, gain control, equalization, classic crossover and linear phase filtering, using double precision filters with 56bit internal processing. This enables a noticeable reduction in distortion with clean and clear equalization. The DSP incorporates sophisticated double protection limitation; RMS and Peak. The RMS limiter is used to adjust the transducer reproduction level, maintaining the original dynamics whilst at the same time respecting the original transients and achieving a better acoustical result. The Peak limiter controls the movement of the speaker, protecting it from any damage and also reducing distortion caused by over-exursion. These double dynamics lower levels of distortion and provide protection for all the speaker components and internal electronics.

TEMPERATURE & PROTECTION CONTROL

Via internal sensors a micro controller analyzes in real time the temperature of each power module. It then automatically adjusts the fan speed to apply the correct temperature dissipation, reducing both the speed of the fan and the noise generated leaving the system as quiet as possible.

COMPONENTS

Transducer and driver with neodymium magnet groups. Nomex cones and suspension for the transducer with weather protected membrane for outdoor use and ventilated voice coil for improved heat dissipation. Titanium diaphragm for the HF driver increasing the life of the components, Shorting copper cap for extended HF response mounted on a 80° x 50° constant directivity rotatable aluminium horn.

HARDWARE

Cabinet constructed from premium birch plywood and finished with high-resistant water based black paint.

SOFTWARE:



- ONLINE CONTROL SYSTEM

Offers detailed system information for each cabinet and via ethernet or PC controls the cabinet/s in real time.



- RAINBOW

Acoustical Prediction software for accurate loudspeaker planning offering both horizontal and vertical views.

ADP-15



DATA SHEET

pag.3/5 V.12.11

HORIZONTAL POLARS

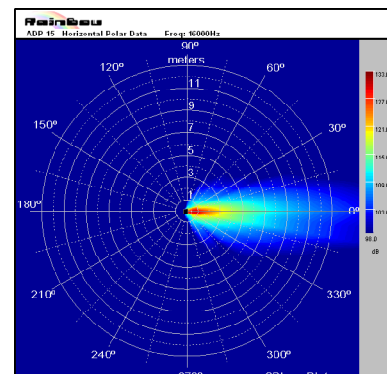
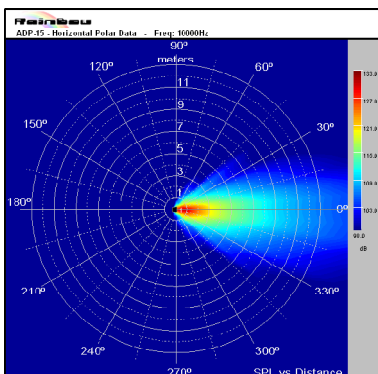
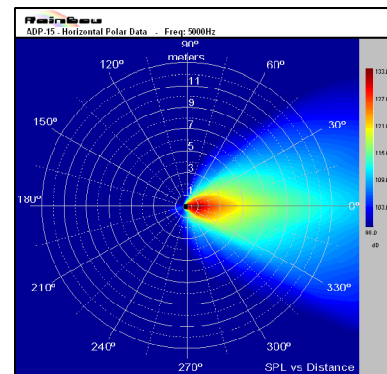
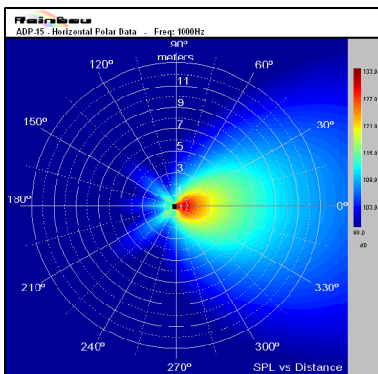
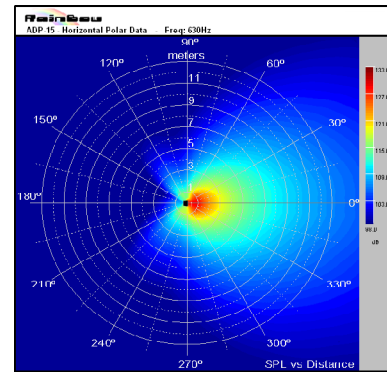
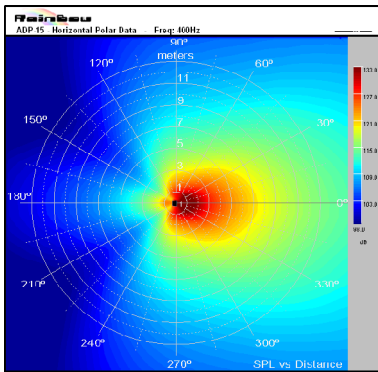
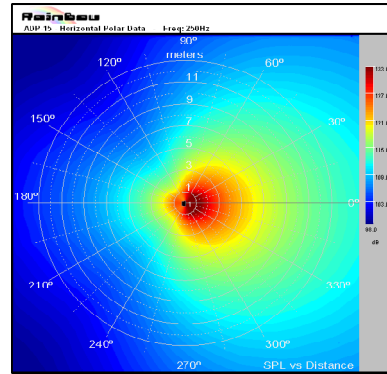
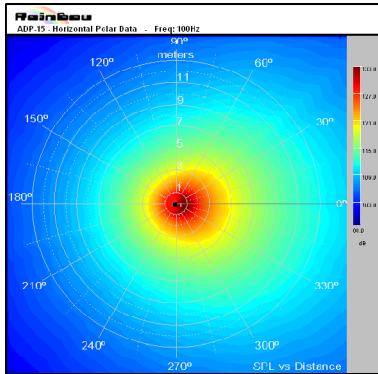

FREQUENCY RESPONSE

FULL RANGE

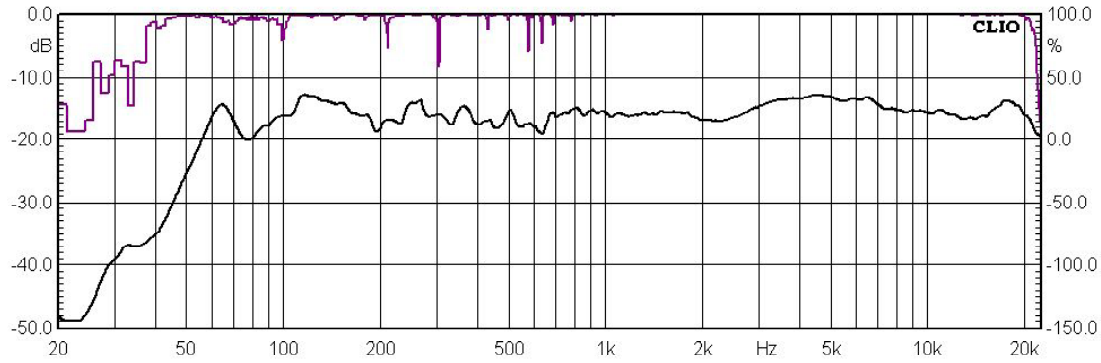

HIGH PASS 80Hz

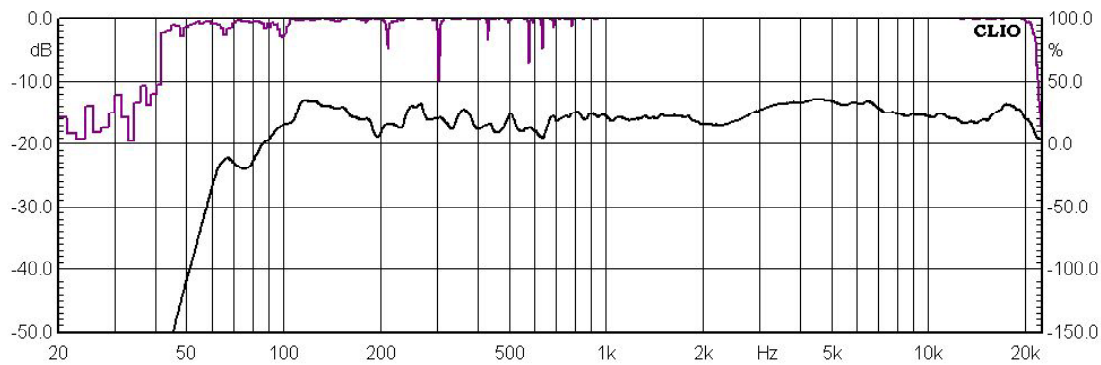

HIGH PASS 90Hz

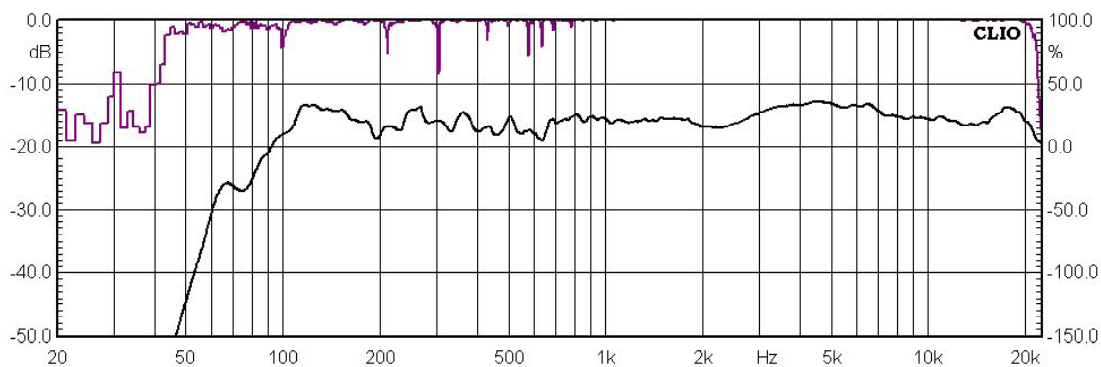

HIGH PASS 100Hz

