



User Manual

Splitter Arma DUO

SPAD-P-2D4D-AC, SPAD-P-2D4D-DC, SPAD-M-2D4D-AC,
SPAD-M-2D4D-DC, SPBD-0-2D4D-AC, SPBD-0-2D4D-DC

Contents

Specifications	3
Safe operation	3
General information	3
Advantages	3
Connection types	4
LED indication	4
Connection scheme	5
Technical maintenance	6

Specifications

Supported protocols	DMX512, RDM, Modbus
DMX input ports	1 or 2 isolated
DMX output ports	4 or 5 isolated
DMX connectors	15EDGVC terminal blocks
Mounting	Surface, Truss
Setup	DIP switchers
Power supply	~90-250 VAC, 50/60 Hz or 9-36VDC
Operating Temperature:	-40°C... +70°C
IP Rating	IP 65
Dimensions, mm	115(D) x 55(H) x 90(W)

Safe operation

In installation, operation, preventive maintenance and repairs of the device, the requirements of the safety rules must be followed.

To ensure safe and reliable operation of the devices, please observe the following requirements:

Use the device only for its intended purpose

Do not use devices that shows signs of malfunctioning

Avoid strong physical impacts on the device

Protect devices and cables from contact with corrosive liquids

Whenever a fault is detected in the device, please contact the manufacturer.

Warning!

The device uses hazardous voltage AC 100-250V

General information

Splitter Arma DU0 is a dual-channel device with 6 DMX input/output ports that operates as a regular splitter with 1 input and 5 outputs as well as two separated 1-to-2 splitters.

All input and output channels are galvanically isolated from each other. The device is suitable for outdoor use and has the highest levels of dust and moisture protection. The device is powered by 100-250V industrial AC mains, power consumption is less than 5 watts. Input, output DMX cables and power cable are connected to the device body via cable glands.

Advantages

Supports bidirectional communication (DMX512 and RDM).The device is suitable for use outdoors

All input and output ports have galvanic isolation

The device is suitable for use outdoors

Power consumption is less than 3W

Connection types

Before mounting and power up, it is necessary to verify protective earthing and cable connectors.

1. Ensure the device has no damage due to transportation.
2. Remove device lid. If the device fixation is needed on a surface, wall, farm, attach the device housing to a surface, or install the appropriate fastening element. Connection scheme located on the backside of the lid.
3. Use the package connectors kit to connect DMX cables. In the scheme given the location of contacts Data +, Data – and Common for input (IN) and output (OUT1-OUT5) terminal blocks.
4. Set position of 4-section DIP-switcher in accordance with needed device configuration.
5. All input and output channels have 120 Ohm terminators, managed by special DIP-switches TIN, T(1)–T(5). To connect the terminator to the line is necessary to set proper switcher in ON position, to disconnect- in OFF position.
6. Connect power supply terminal ~230 V. Some modifications of the device can be equipped with additional ground contact for terminal input power supply connected to the device. Apply power to the device.
7. When device properly connected, the LED indicator on the device is lit. Its color indicates the presence of a valid DMX input signal: Green - present, Red - missing.
8. Cover back the device lid.
9. The device is ready for use.

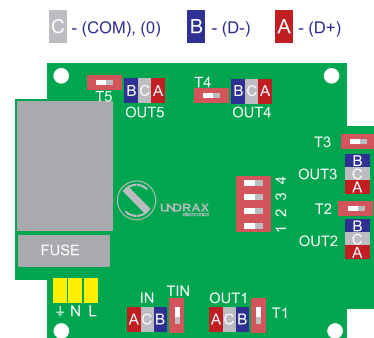

Pic. 1
System board

	ON	OFF
SW1	RDM enabled	RDM disabled
SW2	Dual splitter mode	Single splitter mode
SW3	Full transparent mode	Dedicated input(s) mode
SW4	Bus indication mode	DMX512 indication mode

LED indication

	DMX512 mode	Bus mode
Green	Valid DMX signal	Bus is idle
Red	No DMX signal	Bus is busy
Off	Device/Section doesn't work	Device/Section doesn't work

Connection scheme

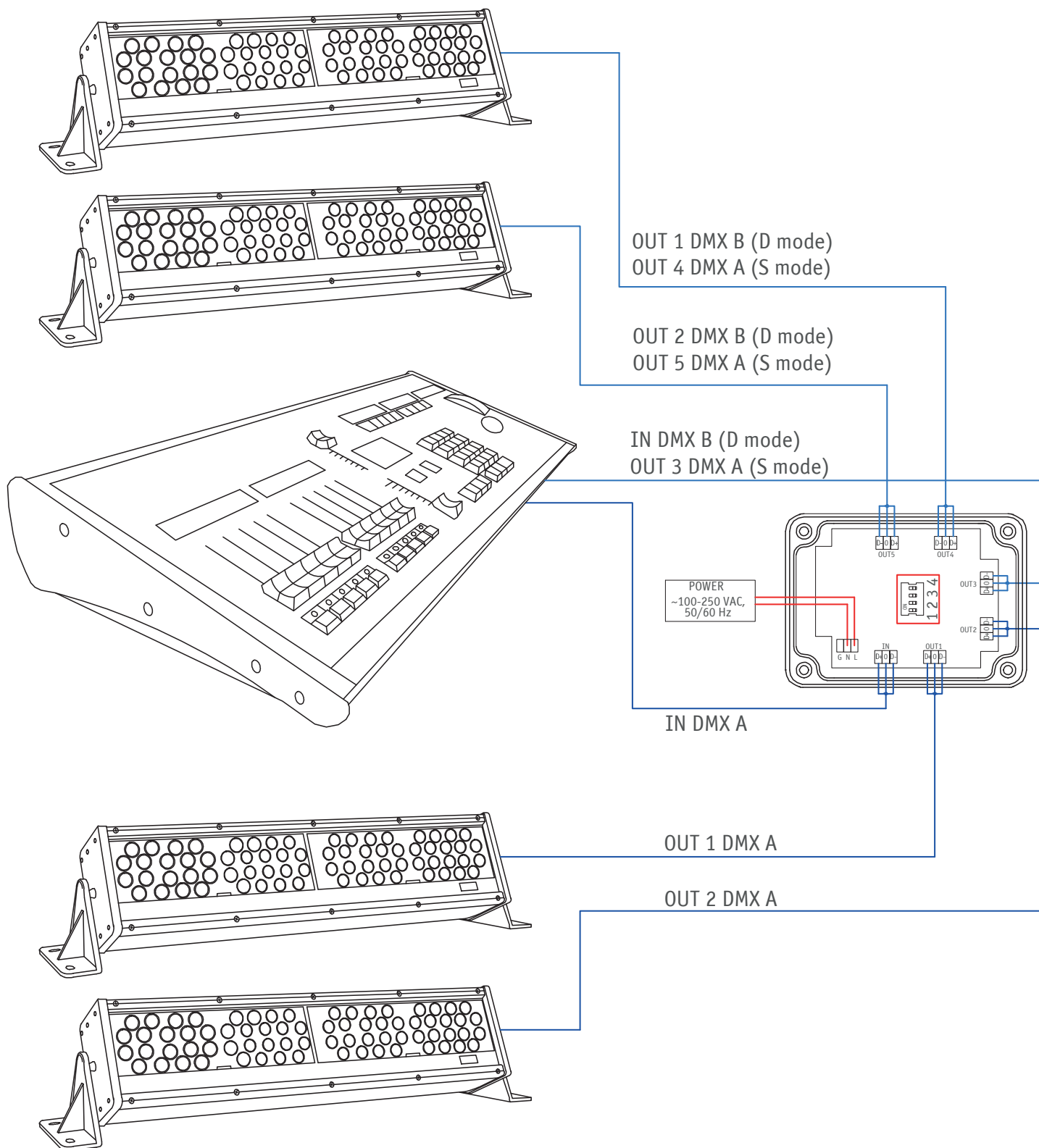

Technical maintenance

Maintenance the device, search and troubleshooting should be performed by service personnel. The device should be free from dirt, dents, connecting cables and wires must be intact and securely fastened.

Notes

Notes



Sundrax Electronics
6008, First Central 200
2 Lakeside Drive, Park Royal, London
NW10 7FQ United Kingdom
+ 44 (0) 208 991 33 19
office@sundrax.com
www.sundrax.com