

# ProPlex<sup>®</sup>

DATA DISTRIBUTION



## BuckBoost™ System User Manual

## **ProPlex BuckBoost™ System User Manual**

ProPlex-BuckBoost™-System-Manual-v1.0  
Effective 7 December 2022

© Copyright 2022, TMB All rights reserved

TMB authorizes its customers to download and print this electronically published manual for professional use only. TMB prohibits reproduction, modification, or distribution of this document for any other purposes, without express written consent.

Specifications are subject to change without notice. The information in this document supersedes all previously supplied information before the effective date listed above. TMB has confidence in the accuracy of the document information herein but assumes no responsibility or liability for any loss occurring as a direct or indirect result of errors or exclusions whether by accident or any other cause.

# LIMITED WARRANTY

ProPlex Data Distribution Devices are warranted by TMB against defective materials or workmanship for a period of two (2) years from the date of original sale by TMB.

TMB's warranty shall be restricted to the repair or replacement of any part that proves to be defective and for which a claim is submitted to TMB before the expiration of the applicable warranty periods.

This Limited Warranty is void if the defects of the Product are the result of:

- Opening the casing, repair, or adjustment by anyone other than TMB or persons specifically authorized by TMB
- Accident, physical abuse, mishandling, or misapplication of the product.
- Damage due to lightning, earthquake, flood, terrorism, war, or act of God.

TMB will not assume responsibility for any labor expended, or materials used, to replace and/or repair the Product without TMB's prior written authorization. Any repair of the Product in the field, and any associated labor charges, must be authorized in advance by TMB. Freight costs on warranty repairs are split 50/50: Customer pays to ship defective product to TMB; TMB pays to ship repaired product, ground freight, back to Customer.

This warranty does not cover consequential damages or costs of any kind.

A Return Merchandise Authorization (RMA) Number must be obtained from TMB prior to return of any defective merchandise for warranty or non-warranty repair. For all repairs please contact TMB Tech Support Repair using the contact information below or email [TechSupportRepairNA@tmb.com](mailto:TechSupportRepairNA@tmb.com).

## US

527 Park Ave.  
San Fernando, CA 91340  
Tel: +1 818.899.8818  
Fax: +1 818.899.8813  
[tmb-info@tmb.com](mailto:tmb-info@tmb.com)  
[www.tmb.com](http://www.tmb.com)

## UK

21 Armstrong Way  
Southall, UB2 4SD England  
Tel: +44 (0)20.8574.9700  
Fax: +44 (0)20.8574.9701  
[tmb-info@tmb.com](mailto:tmb-info@tmb.com)  
[www.tmb.com](http://www.tmb.com)

# PRODUCT OVERVIEW

ProPlex's BuckBoost™ Drive System is a unique, patent-pending technology that completely overcomes the cable length challenges of low voltage LED lighting, especially LED “neons” and tapes. This revolutionary new system allows centralized main control (BoostBox™) with remotely located drives (BuckBox™) up to 150m away. The proprietary BuckBoost™ drive signal is carried over a small cable, sized equivalent to a mic cable, from a remote BoostBox™ to a small inconspicuous BuckBox™ located adjacent to the fixture.

The BuckBoost™ System also incorporates ProPlex proprietary SmartFade® dimming. This industry-leading high resolution Dimming technology provides advanced features including:

- Gamma correction
- Smooth, linear fades, 100% to zero
- Instant response times
- Variable PWM frequency - 300 to 40,000 Hz.

## BOOSTBOX8

### Front XLR

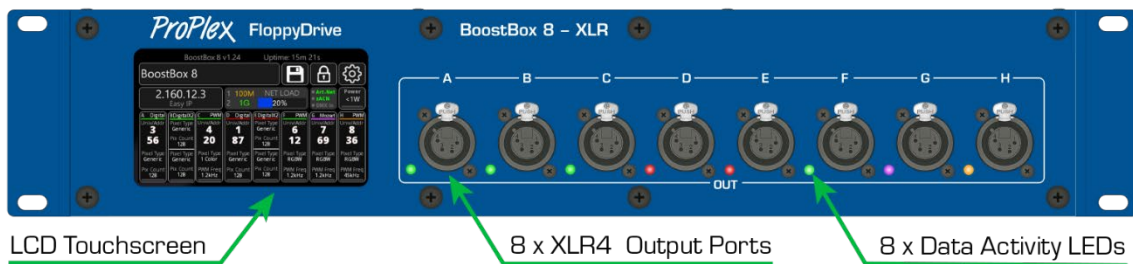

### Front PTB

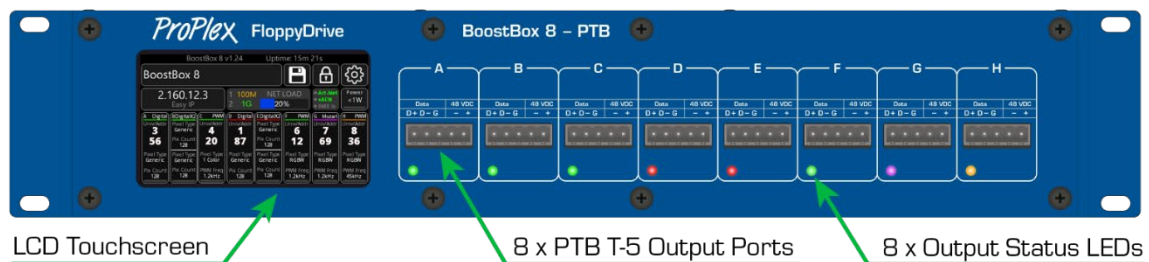

### Rear



# BOOSTBOX4

## Front XLR

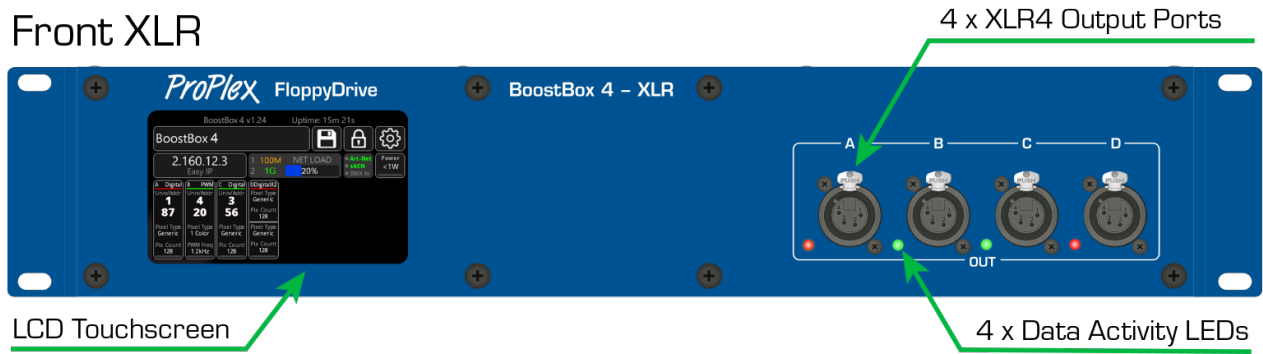

## Front PTB

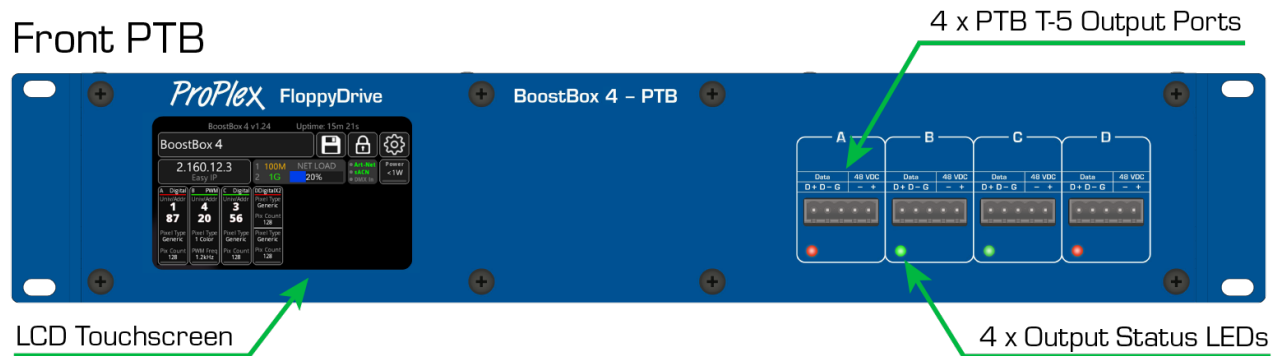

## Rear

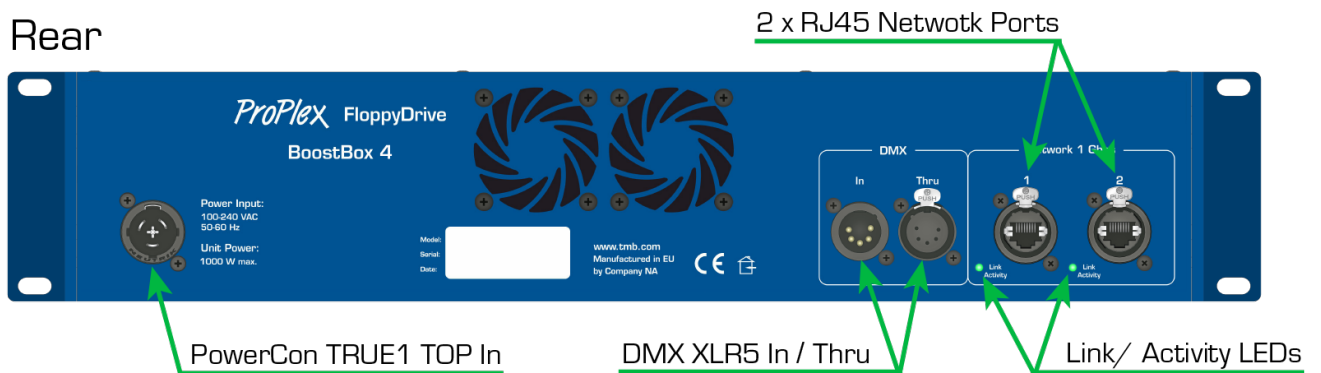

# BOOSTBOX2 PORTABLEMOUNT

## Front

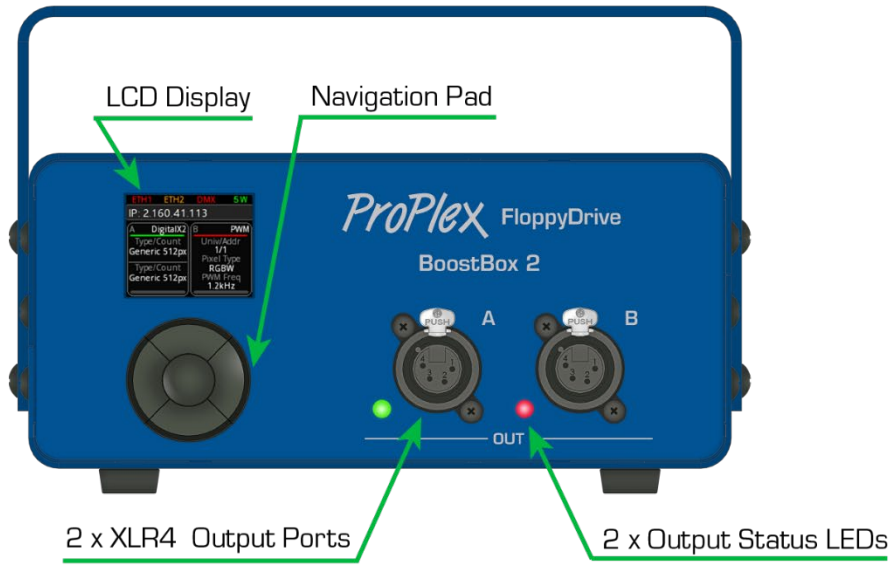

## Rear

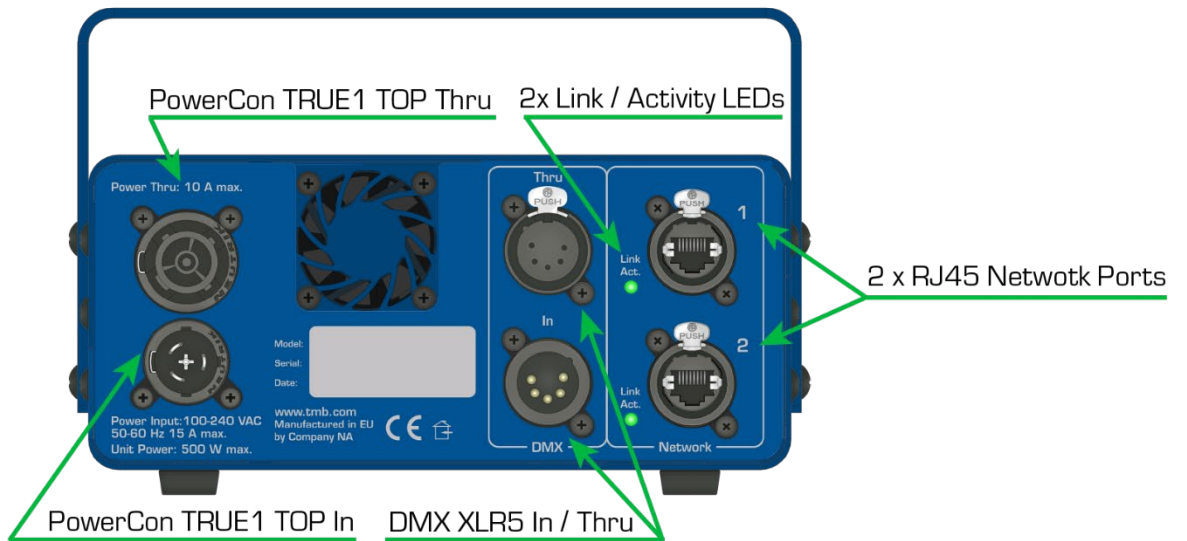

## BoostBox 2 DIN

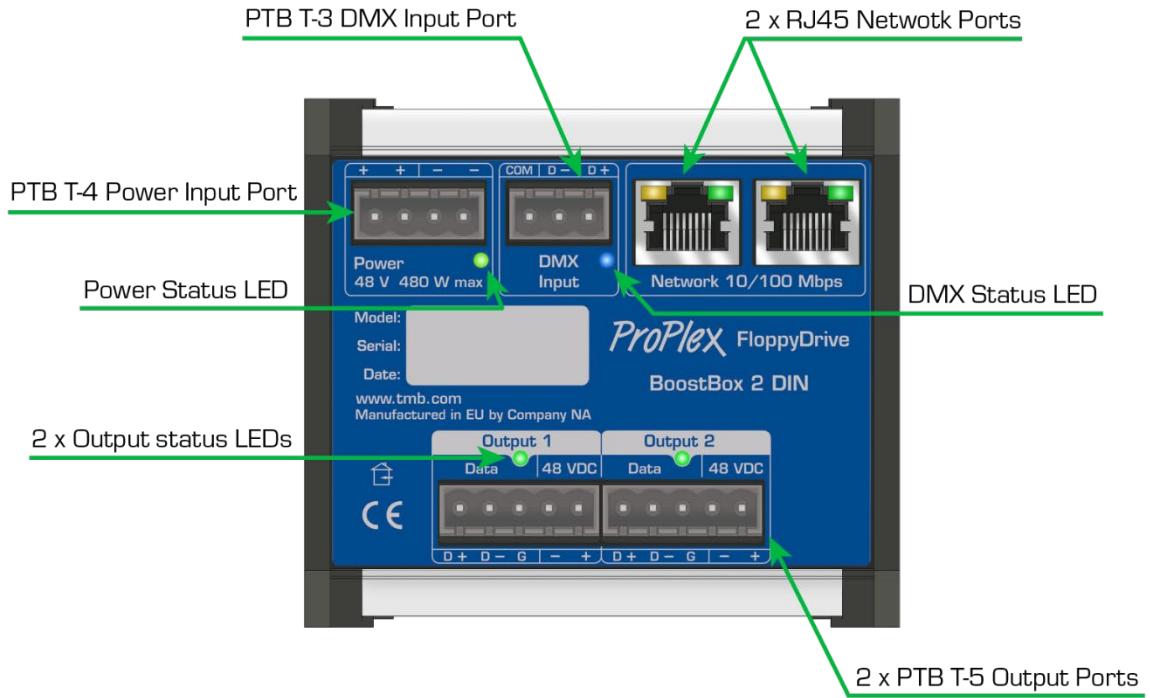

**BUCKBOX 1 UNIVERSAL IP67**

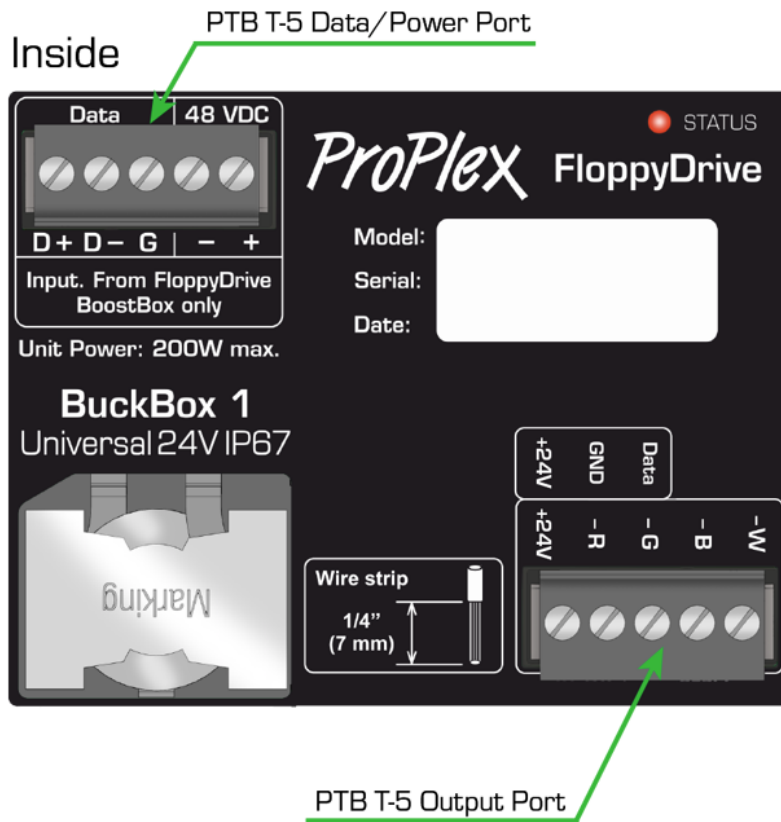
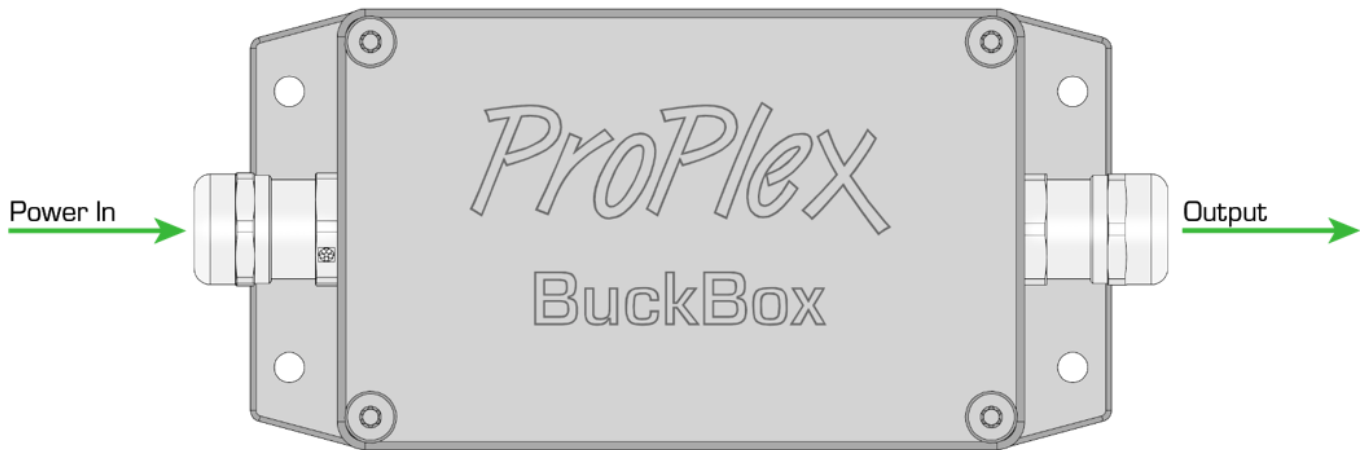



# BuckBox 2 DIGITAL IP67

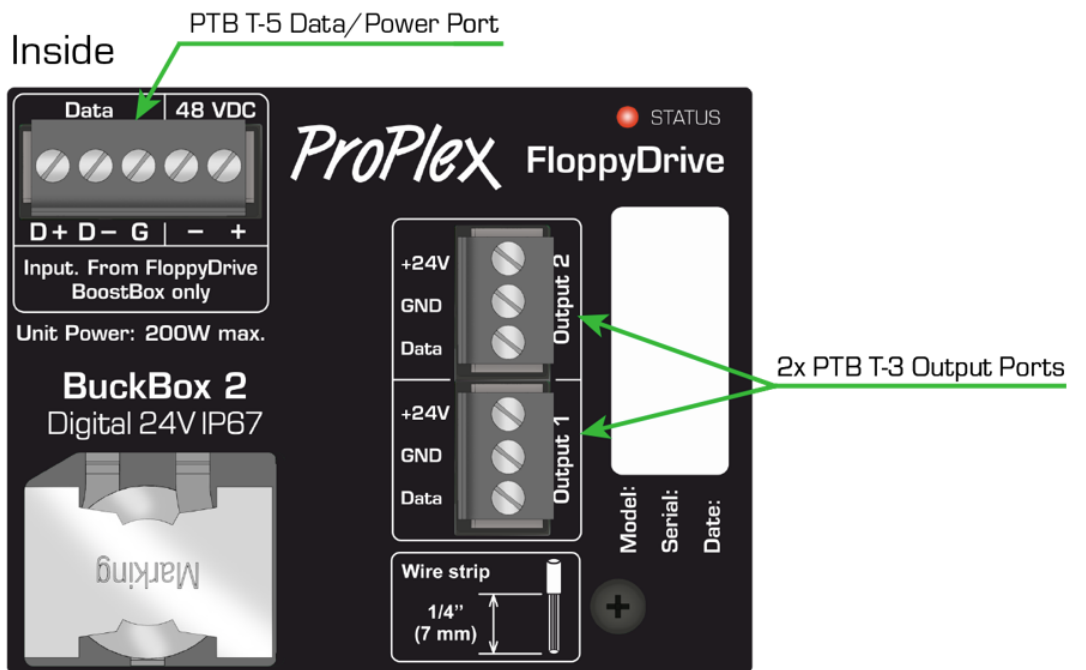
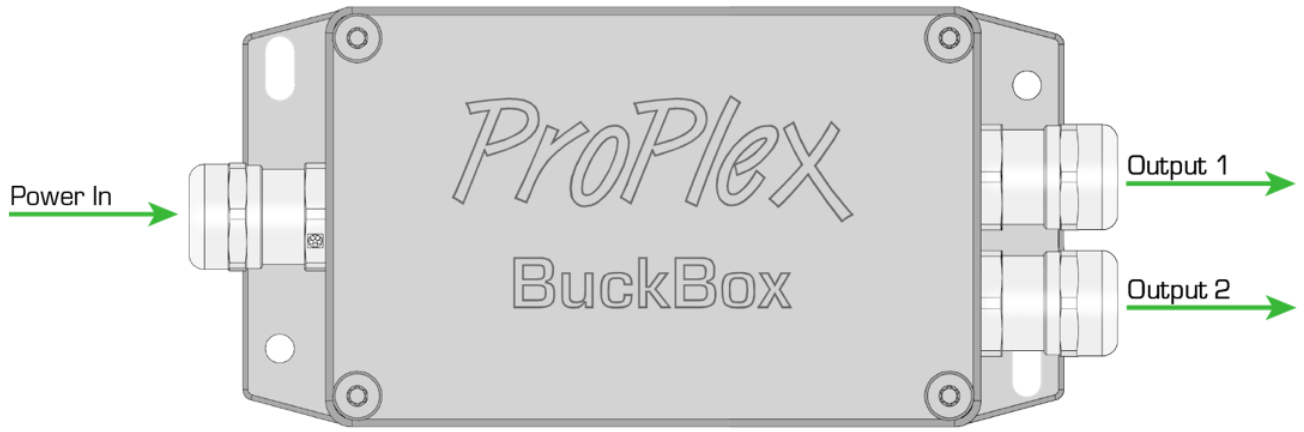

**BUCKBOX 1 UNIVERSAL PORTABLEMOUNT**

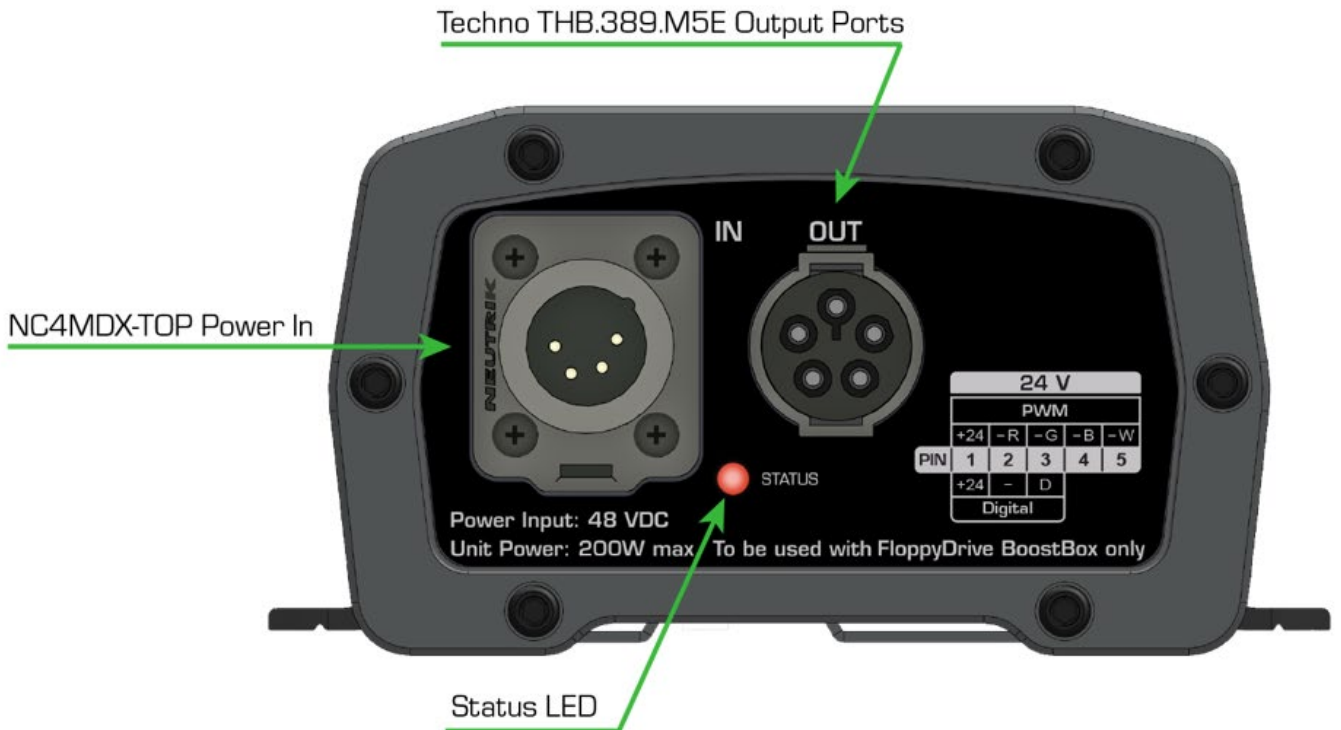
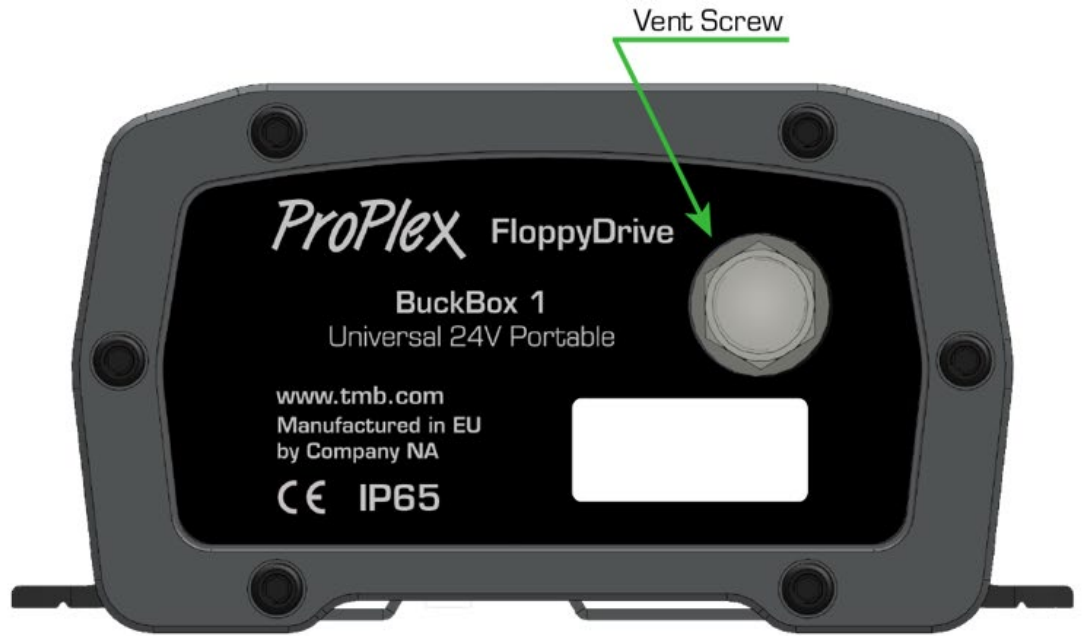

**BUCKBOX 2 DIGITAL PORTABLEMOUNT**

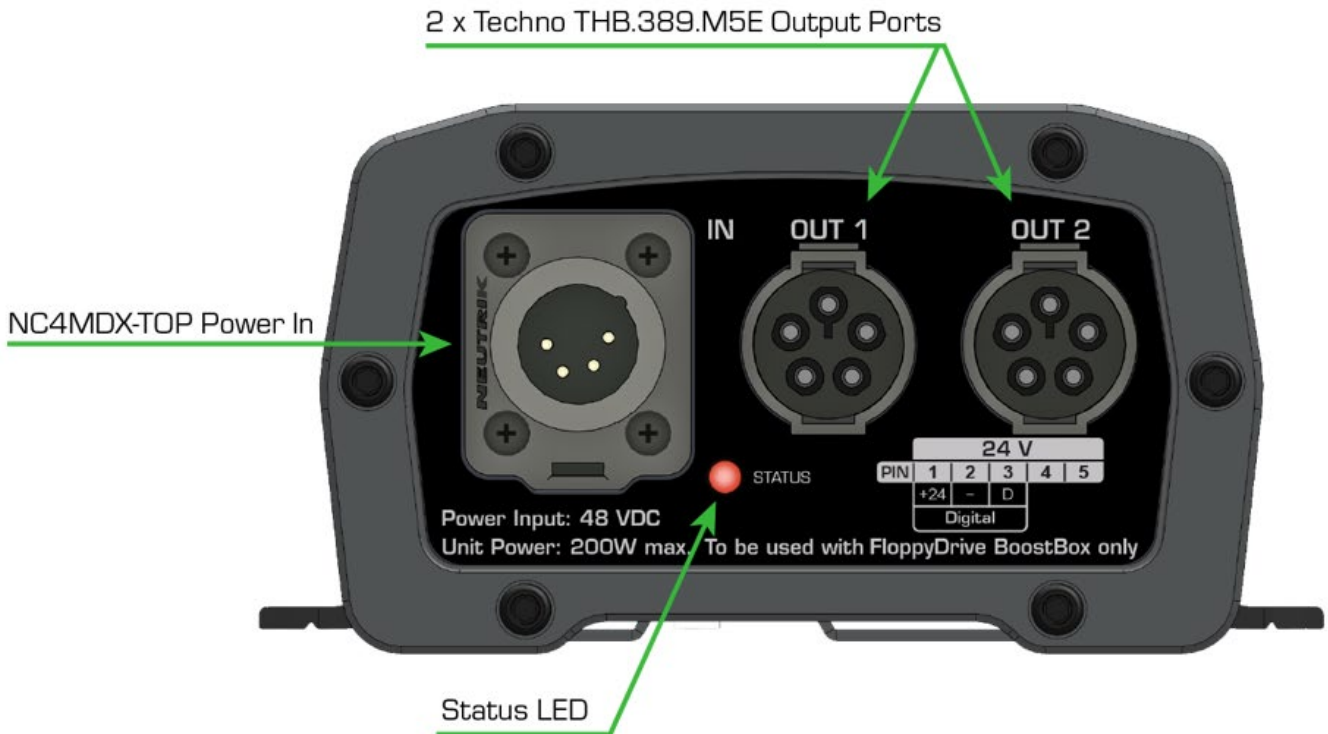
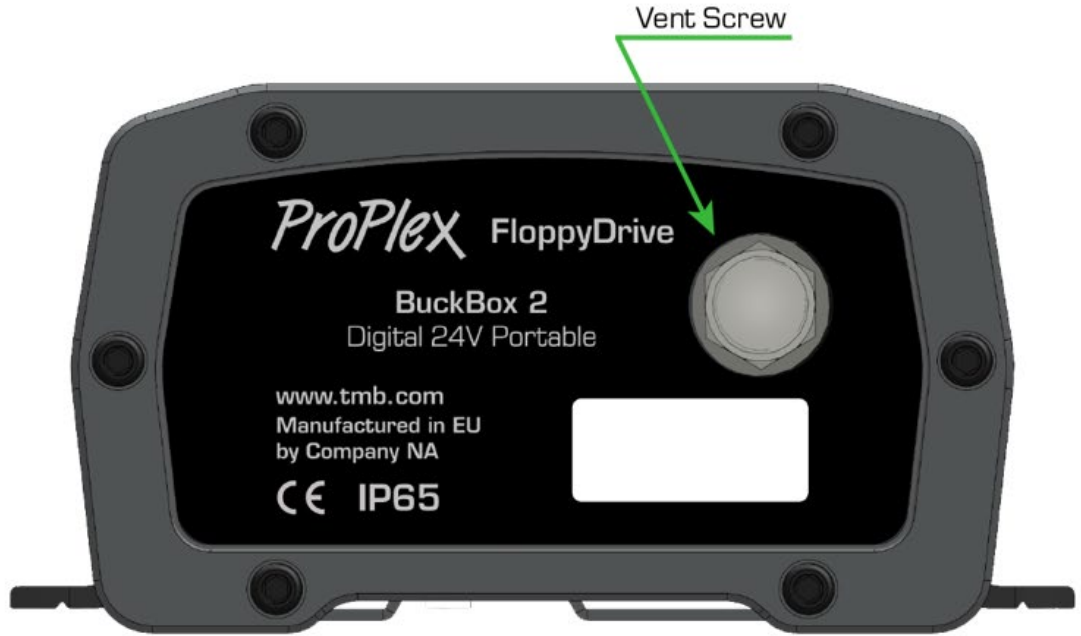

# SETUP

## UNPACKING INSTRUCTIONS

Upon receipt of the unit, carefully unpack the carton and check the contents to ensure that all parts are present and in good condition. Notify the shipper immediately and retain packing material for inspection if any parts appear to be damaged from shipping or if the carton itself shows signs of mishandling. Save the carton and all packing materials. In the event that a unit must be returned to the factory, it is important that it be returned in the original factory box and packing.

## POWER REQUIREMENTS

Before powering any equipment, make sure the line voltage is within the range of accepted voltages. These units accommodate 100-240VAC, 50/60Hz. All units must be powered directly from a switched circuit and cannot be operated with a rheostat (variable resistor) or dimmer circuit, even if the rheostat or dimmer channel is used solely for a 0-100% switch.

## SAFETY INSTRUCTIONS



Please read these instructions carefully. This user guide contains important information about the installation, usage and maintenance of this product.

- Keep this User Guide for future reference. If unit is sold to another user, make sure they also receive this instruction booklet.
- Ensure the unit is connected to proper voltage, and that line voltage is not higher than that stated on the device.
- Make sure there are no flammable materials close to the unit while operating.
- Always disconnect from the power source before servicing or fuse replacement. Always use the fuse specified in this manual.
- Always use a safety cable when hanging unit overhead.
- Maximum ambient temperature (Ta) is 40°C (104°F). Do not operate unit at temperatures above this rating.
- In the event of a serious operating problem, stop using the unit immediately. Repairs must be carried out by trained, authorized personnel. Contact the nearest authorized technical assistance center. Only OEM spare parts should be used.
- Do not connect the device to a dimmer pack.
- Make sure power cord is never crimped or damaged.
- Never disconnect power cord by pulling or tugging on the cord.

**Caution! There are no user serviceable parts inside the unit. Do not open the housing or attempt any repairs yourself. In the unlikely event your unit may require service, please contact your distributor.**



Disconnect the power cord before replacing a fuse and always replace with the appropriate fuse.



## MOUNTING/RIGGING – PROPLEX ENCLOSURES



Always consult a certified rigging specialist before suspending any device overhead.



Use ProBurger® couplers or equivalent C- or O-type clamps for attaching to truss. After establishing the desired position, tighten all appropriate bolts.

- Always use safety cables!
- When selecting installation location, consider routine maintenance.
- Never mount Mini enclosure where it will be exposed to moisture, high humidity, extreme temperatures, or restricted ventilation.

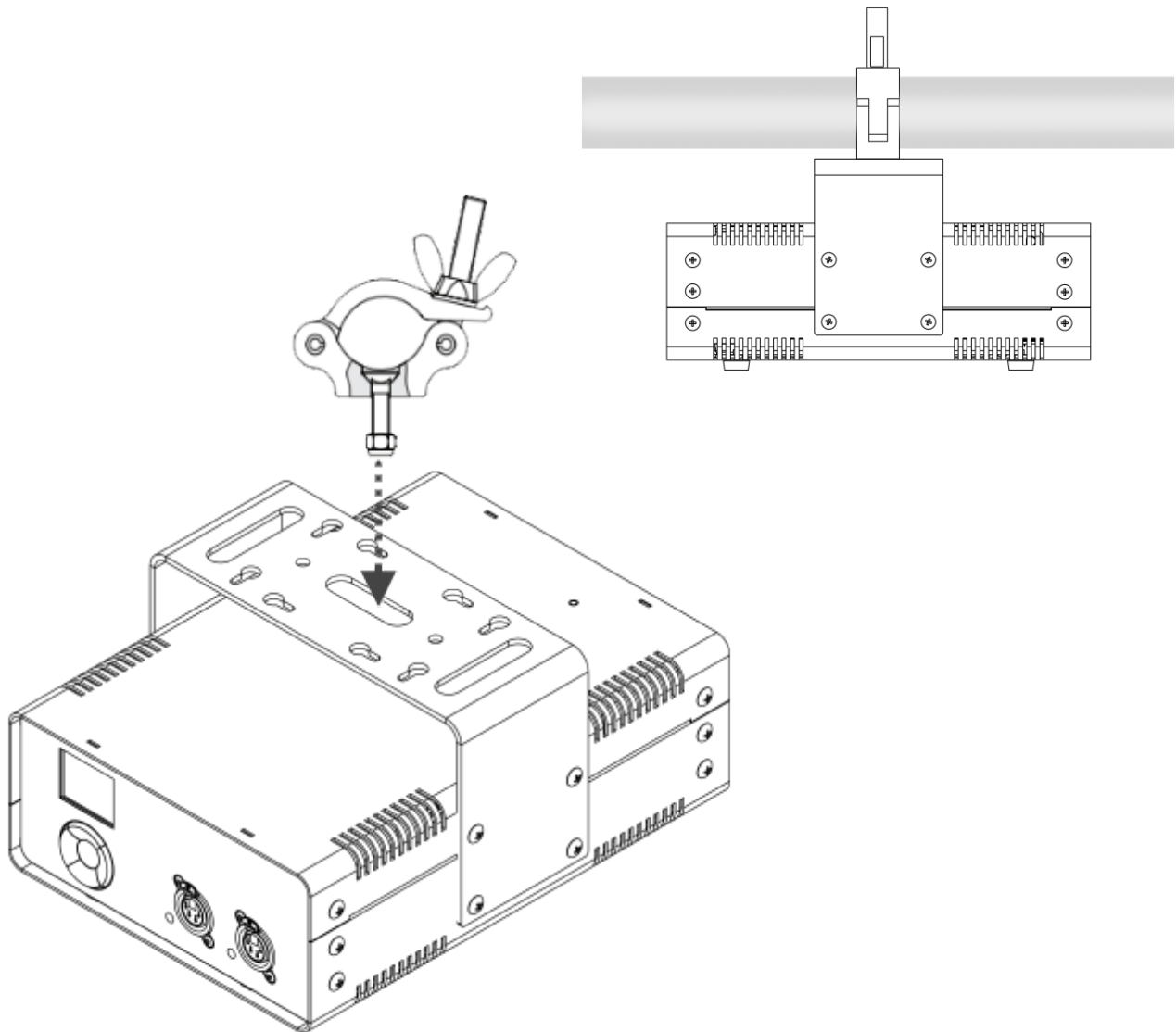

## RACKMOUNT KITS

ProPlex RackMount Kits are designed to allow easy rack mounting of ProPlex PortableMount units.

ProPlex PortableMount enclosures include a yoke for truss mounting. Before attaching RackMount Kit, remove the yoke by unscrewing four Phillips-head (crosshead) screws which attach the yoke to the chassis.

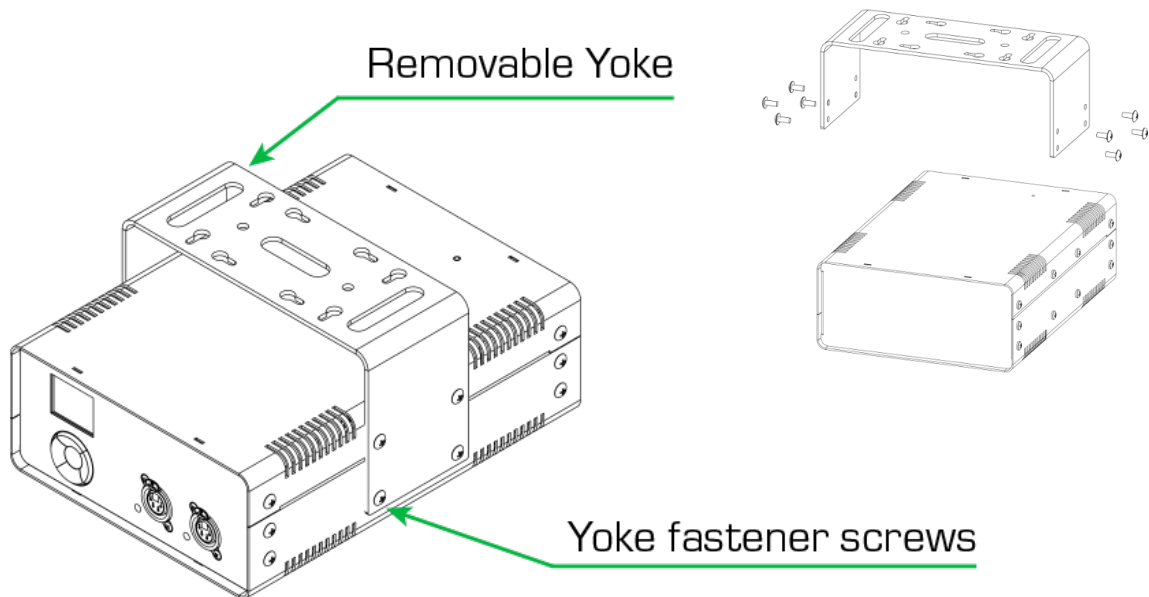

**Important:** Be sure to reinsert the yoke screws into the unit after yoke has been removed. Store yoke in a safe place until needed again.

## INSTALLING THE RACKMOUNT EARS

ProPlex RackMount Kits are available for both Single-unit and Dual-unit mounting configurations. The 1U RackMount Kit Single is comprised of two rack ears, one long and one short. The Dual has two short rack ears + two dual joiners for front and rear of the units.

To fasten the rack ears to the ProPlex PortableMount chassis, remove the two chassis screws on each side that align with the rack ear mounting holes at the front of the chassis. Then use the same screws to securely fasten the ears to the chassis, per below illustrations. The short and long ears can be mounted to either side of the chassis.

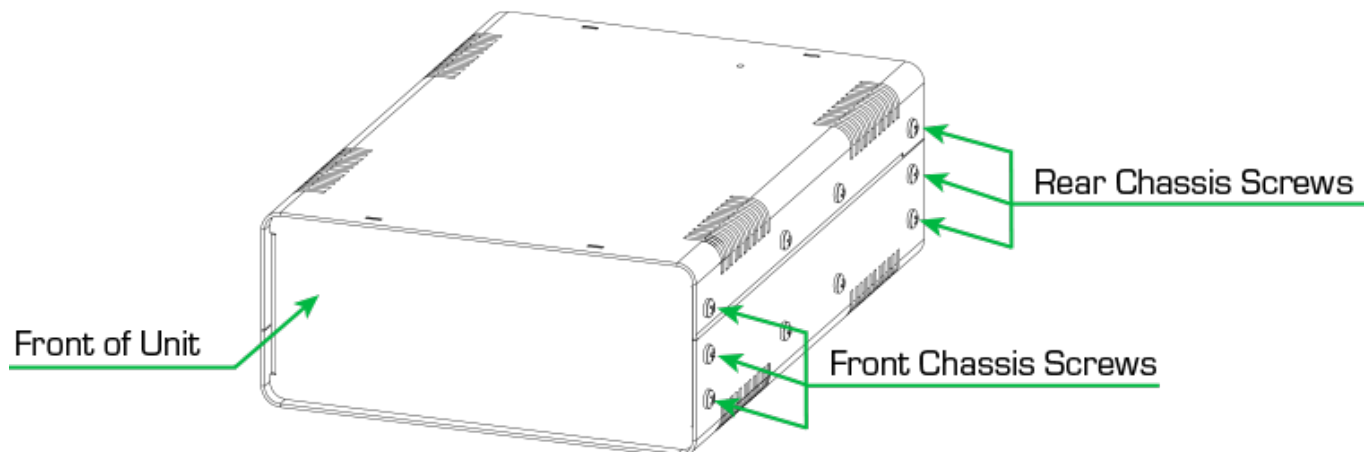

The drawing below depicts the completed installation of the Single-Unit Large RackMount Kit. These rack ears are designed to be symmetrical, so that the short and long ears can be mounted to either side of the chassis.

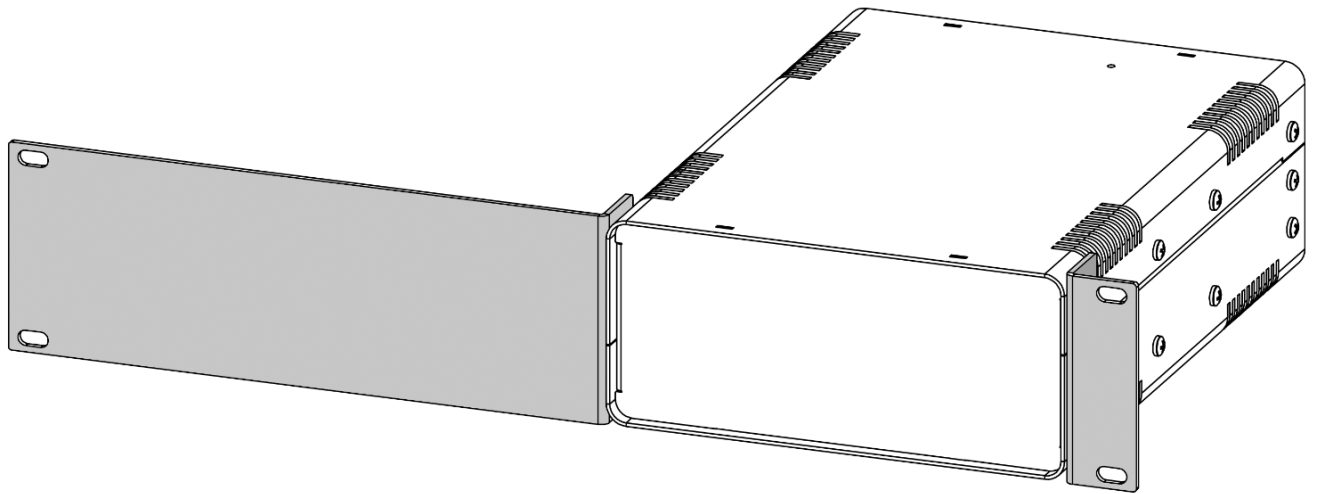

The drawing below depicts the completed installation of the Dual-Unit Large RackMount Kit. The Dual-Unit version requires TWO center Dual Joiners (included in the Kit), attached at the front and rear of the units, enhancing stability in the rack.

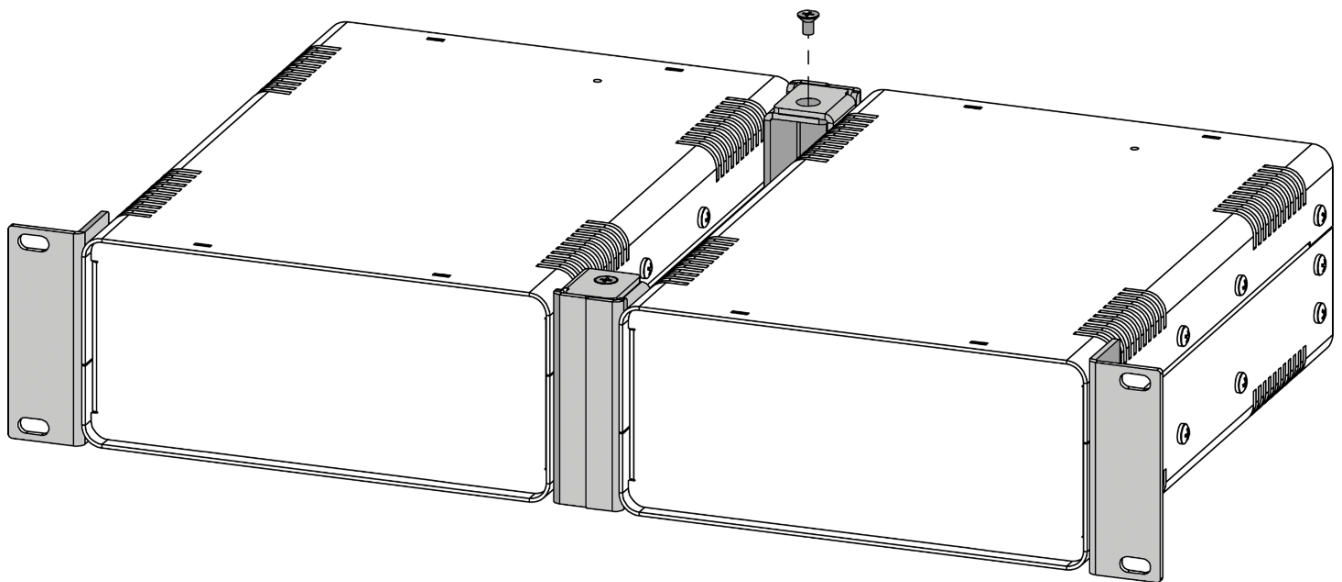



## INSTALLING THE DUAL JOINERS

The Dual-unit Large RackMount Kit will include four joining links and FOUR countersunk flat head screws. These links are designed to nest into each other and are secured with the included screws and threaded holes.

Each link piece is identical. Simply rotate the joining link and line up the installation holes to install on either the left or right side of the corresponding unit.

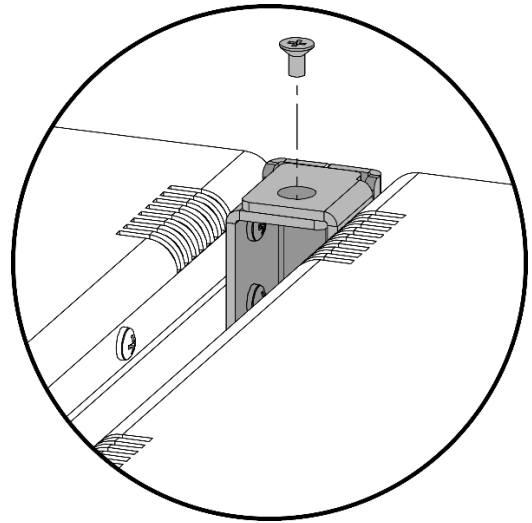
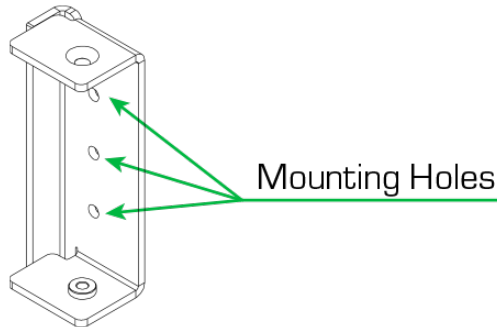

## MOUNTING IN THE RACK

When installing multiple units, they can be mounted on alternating sides of the rack, side by side, or underneath one another. Please ensure adequate airflow when mounting one above the other, whether in Single or Dual Mounting configurations.



Allow minimum  $\frac{1}{2}$  U rack space between assemblies

## RACKMOUNT KIT ORDERING CODES

When ordering ProPlex RackMount Kit, Single or Dual, be sure and specify "Large" for the BoostBox2 PortableMount

- **PP2RMKITLS** - ProPlex 2U RackMount Kit, Large, Single
- **PP2RMKITLD** - ProPlex 2U RackMount Kit, Large, Dual



# CONNECTION SCHEME

The BoostBox combines mains power and Ethernet or DMX control into a single cable which connects to compact BuckBoxes positioned near the fixture. Using DC/DC conversion, we can compensate for the voltage drop between the remote BoostBox location and the BuckBox unit. This proprietary power+data control system can span distances up to 150 meters, eliminating the need for mains hookups while providing stable control and a relatively small footprint at the fixture installation point

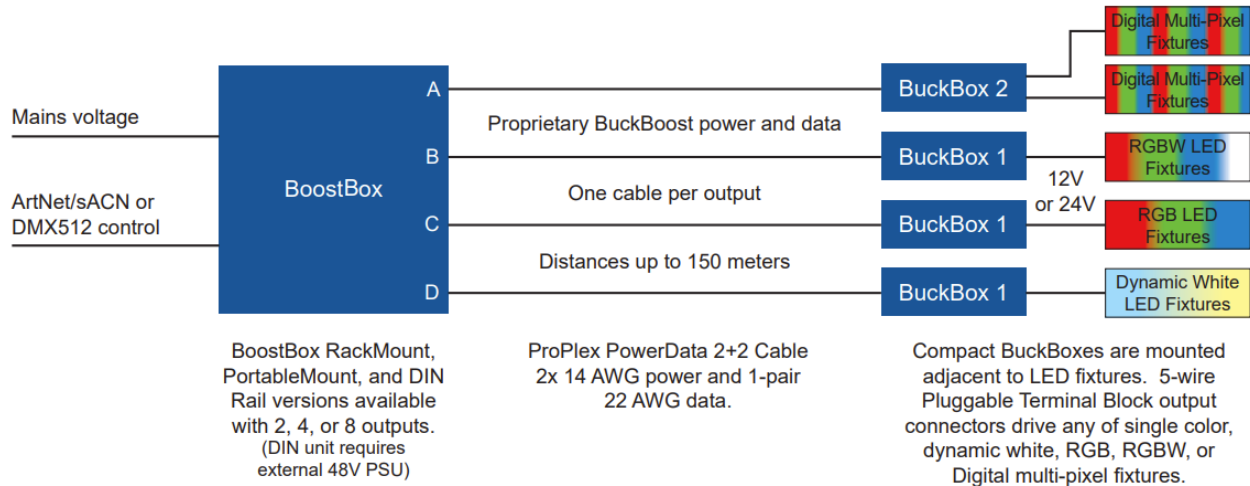

1. Connect an Ethernet cable from your Art-Net or sACN network to either etherCON port on the back of the BoostBox. This will allow remote configuration of the unit via a Web Interface.
  - a. **Note:** Remote configuration is not necessary for BoostBox RackMount or PortableMount products which have onboard navigation through touchscreen or button pad
  - b. **Note:** BoostBox 2 DIN products do not have physical navigation buttons and can only be configured via ethernet connection. IP address of the unit should be clearly marked either on the unit or in the product packaging.
2. A 5-pin DMX input port is also available in BoostBox products for alternate control
3. Connect PowerData Cable between BoostBox and BuckBox with the following wiring specifications:

System Specifications	
System voltage	48 VDC
Current per BoostBox output	5 A
Power per output	240 W
Max power per output to end devices	200 W
Control data	Proprietary Bi-directional 500kBit

Cable Specifications		
Cable type	ProPlex PowerData 2+2* (pn: PCCCT)	
Power available for end devices based on cable length	65 m [220 ft]	200 W
	100 m [330 ft]	180 W
	150 m [500 ft]	160 W

\* Specifications for ProPlex PowerData 2+2 cable can be found at: <https://tmb.com/docs/proplex/powerdata/ProPlex-PowerData-2+2-LTR-web.pdf>

4-pin XLR Connector Wiring		
Pin	Function	Conductor
1	Common (0V)	14 AWG [2.5 mm <sup>2</sup> ] Single
2	Data -	22 AWG [0.34 mm <sup>2</sup> ] Data Pair
3	Data +	
4	48 VDC	14 AWG [2.5 mm <sup>2</sup> ] Single
Shell Tab	Ground	Shield

PTB Connector Wiring		
Pin	Function	Conductor
1	Data +	22 AWG [0.34 mm <sup>2</sup> ] Data Pair
2	Data -	
3	Ground	Shield
4	-48 VDC	14 AWG [2.5 mm <sup>2</sup> ] Single
5	+48 VDC	14 AWG [2.5 mm <sup>2</sup> ] Single

4. Connect the Fixture (LED Neon, Solaris Mozart, etc.) to the output side of the BuckBox following the connection wiring diagrams printed on the units. Refer to fixture manufacturing specs to determine correct wiring pinout
  - a. BuckBox Portable products connect output via the included 5-pin Techno connector and are referenced on the pinout chart printed on the BuckBox unit

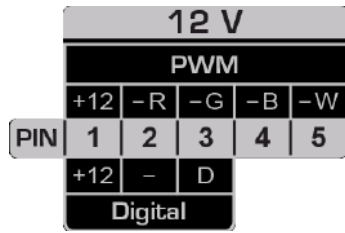

- b. BuckBox IP67 and 2-gang products connect output via PTB (pluggable terminal block) style connectors and are referenced on the pinout chart printed inside the enclosure. **Note:** to ensure IP67 rating, use appropriately fitted cable

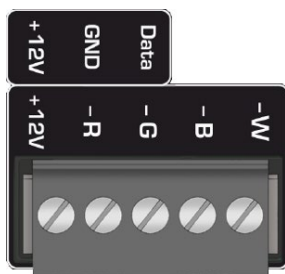

- c. BuckBox Mozart connects output via the standard Amphenol Sensor M12 Mozart connector end and should be able to connect to fixtures or extension cables directly without any complicated wiring

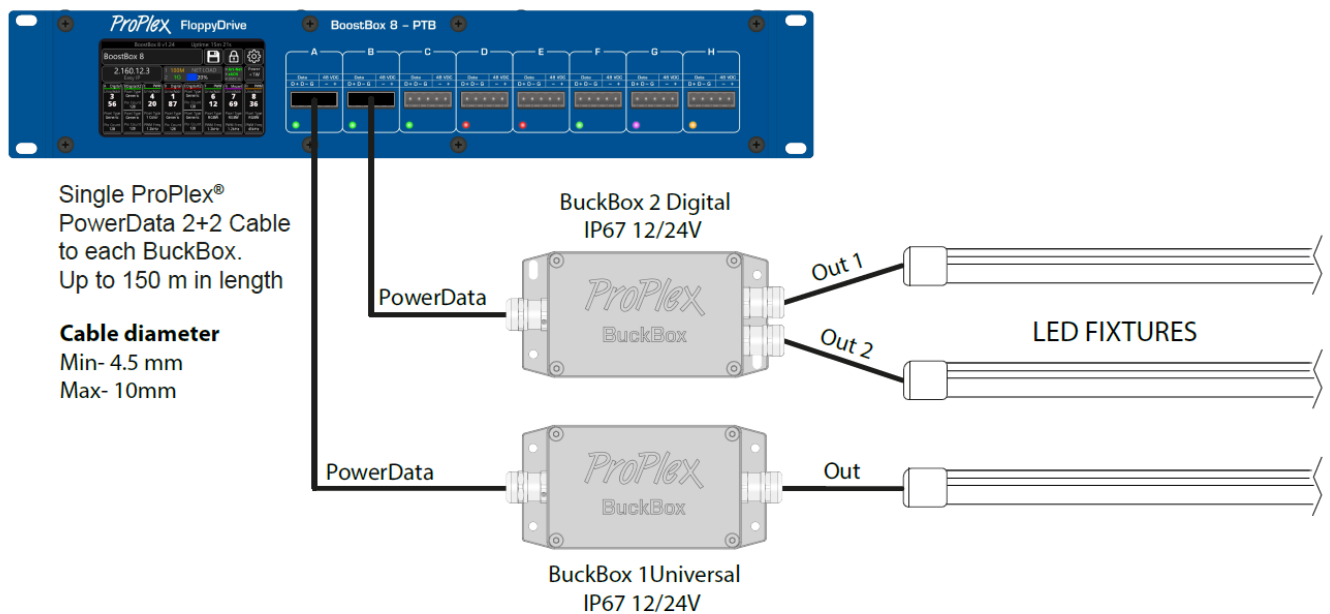

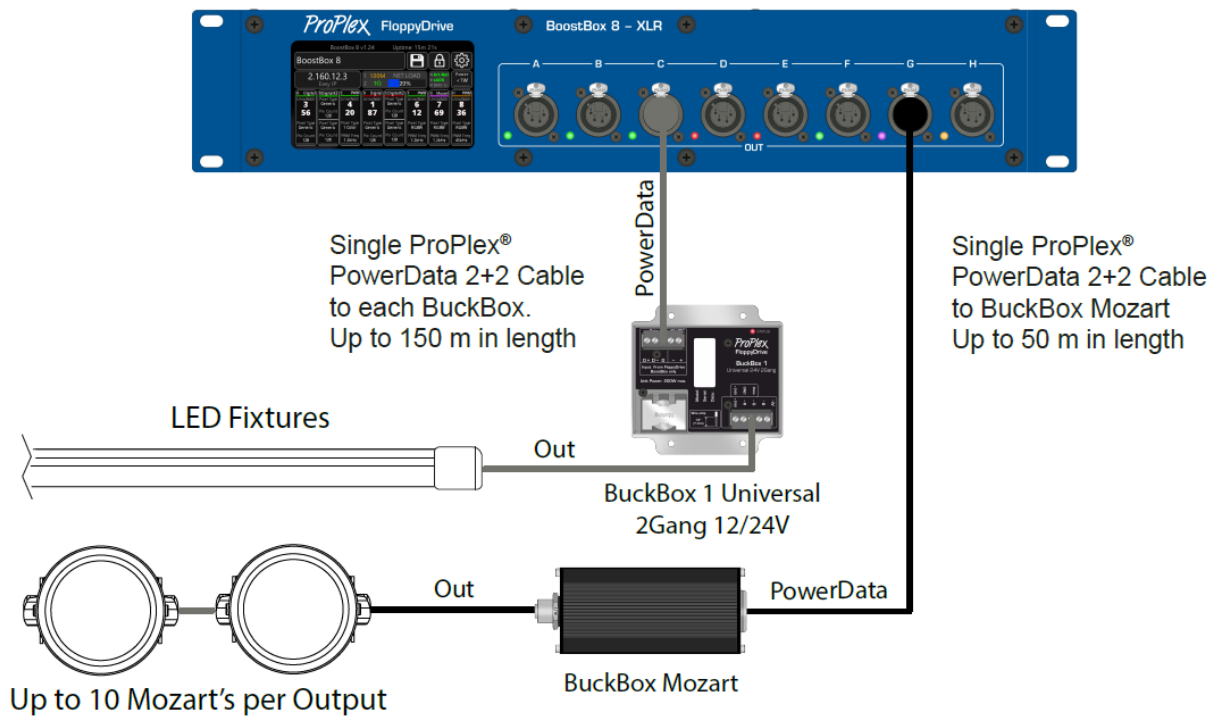
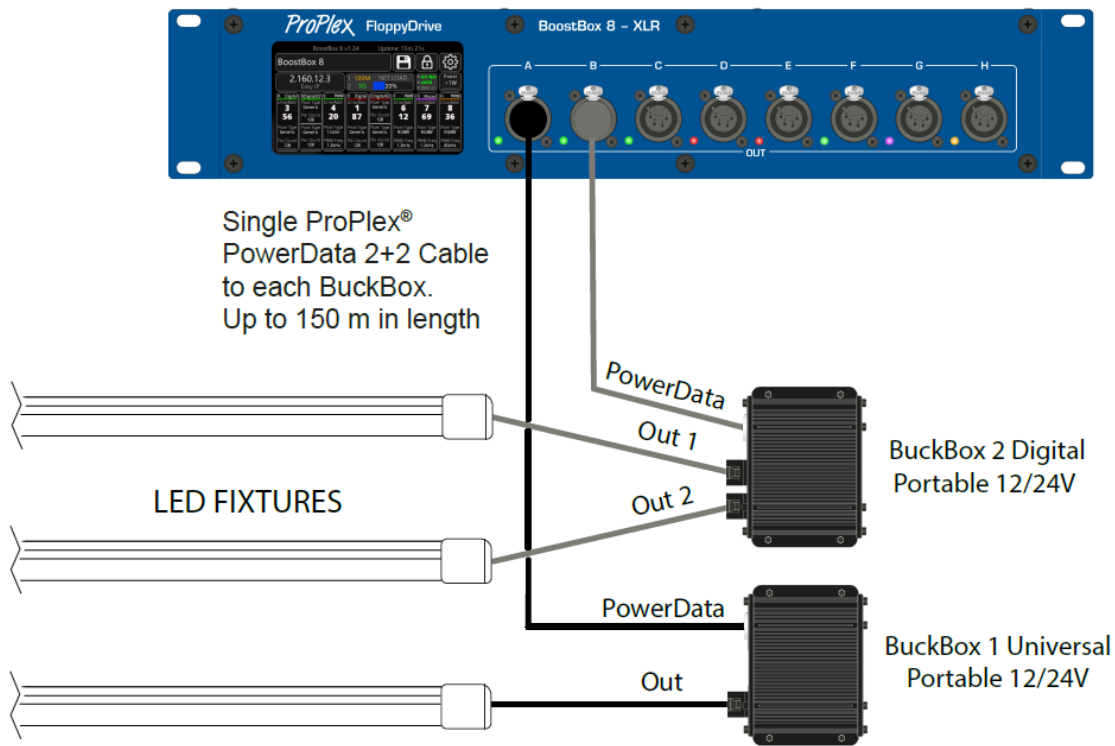

# OPERATION

## OVERVIEW

BoostBox products are shipped unconfigured by default. They will not automatically know what type of BuckBox or lighting fixture is connected.

BoostBox 8 and 4 RackMount products can be configured by the touchscreen control panel on the unit or the browser interface. The Control Panel gives access to all functions directly on the unit itself, with all information displayed on the OLED screen. The web browser is a real-time mirroring of the touchscreen, so any changes made will reflect instantly on both the screen and browser. These methods offer identical access to user-defined settings, so you may choose which configuration method best suits the installation.

BoostBox 2 PortableMount similarly offer a browser interface as well as a control panel on the unit, but the screen is small and navigated by a set of 5 buttons (Up, Down, Left, Right, and Enter).

BoostBox 2 DIN does not have physical navigation buttons and can only be configured via web browser interface. IP address of the unit should be clearly marked either on the unit directly or in the product packaging.

Users wishing to set up BoostBox from the browser interface will need to set a static IP address on whatever machine is being used to access. It must be set within the same network (*ex. IP address 2.x.x.x, Mask 255.0.0.0*). When this is confirmed, simply open a browser of choice and navigate directly to the BoostBox IP address you wish to configure.

# BOOSTBOX 8 NAVIGATION

## Main Screen

Device model and firmware version.

Time since boot up.

Open "Save and Load" menu.

Lock the screen.

Unit name- tap to edit.

Open configuration menu.

IP address and net mask tap to edit network settings.

Total unit power- Tap to open menu with output status details.

Network status: Port link status and speed Unit network load.

- Red - no Link
- Orange - 10/100 Mbps
- Green - 1 G

Port status- Tap each port to configure.

Protocol monitor: Dot color mimics if this protocol is active on network:  
Green = active  
Red = inactive  
Gray = not established  
Protocol label colors:  
Green = enabled  
Gray = disabled

## Main Screen Port Details

Current port mode:

- Disabled
- PWM (BuckBox 1)
- Digital (BuckBox 1)
- DoubleDigital (BuckBox 2).

Patch - universe and DMX address

- White - data being received
- Red - no data

DoubleDigital Output 1 and Output 2 shown separately.

Port status indicator bar:

- Gray - port disabled
- Red - no BuckBox detected
- Orange - wrong type BuckBox connected
- Green - correct BuckBox type found.

Load power bar.

Red background = port overload.

## Port Configuration - PWM

Unit label tap to edit.

Shows available data sources.

DMX Universe tap to select.

DMX Address tap to edit.

Pixel type select:  
• Single Color  
• Dynamic White  
• RGB  
• RGBW

Gamma value:  
Range 1.0 - 5.0.

PWM frequency:  
Range 300 - 40000.

### Port Configuration - Digital

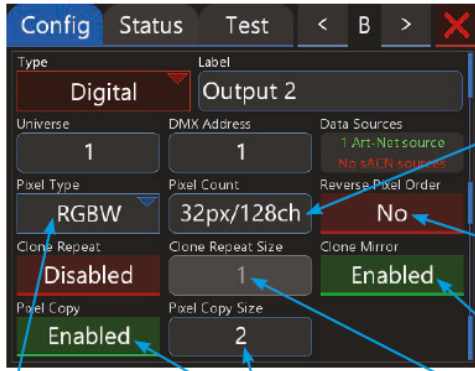

Pixel count. This is needed for pixel reversing and mirroring.

Reverses pixel sequence so addressing starts at the end of FloppyFlex Digital run.

Mirrors pixel order for each section.

Digital pixel type select:  
 • RGB  
 • BRG  
 • RGBW  
 • Dynamic White  
 • White  
 • White X3.

Pixel copy - same input data for multiple consecutive pixels effectively reducing pixel resolution.

Clone repeat - reuses data after given clone size. If set to 1, single pixel will control whole length of digital tape run.

Same parameters as for Digital (repeated for each physical output).

### Port Configuration - Double Digital

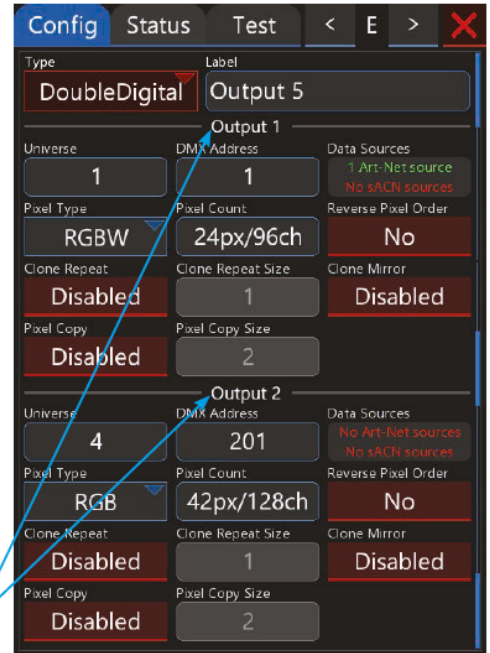

### Port Configuration - Mozart

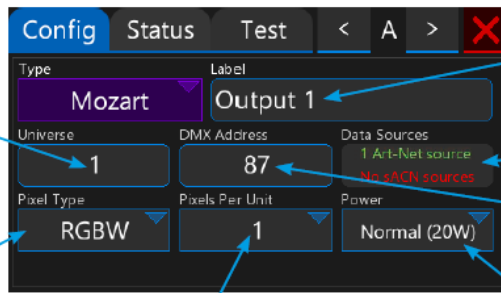

DMX Universe tap to select.

Pixel type select:  
 • White/UV  
 • RGB  
 • RGBW.

Pixels Per Unit (1-16).

Unit label tap to edit.

Shows available data sources.

DMX Address-tap to edit.

Normal (20W) or High Power (40W) mode.

### Device Name

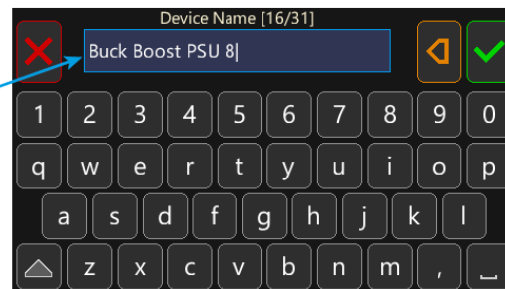

Edit name of the device

## Load and save config

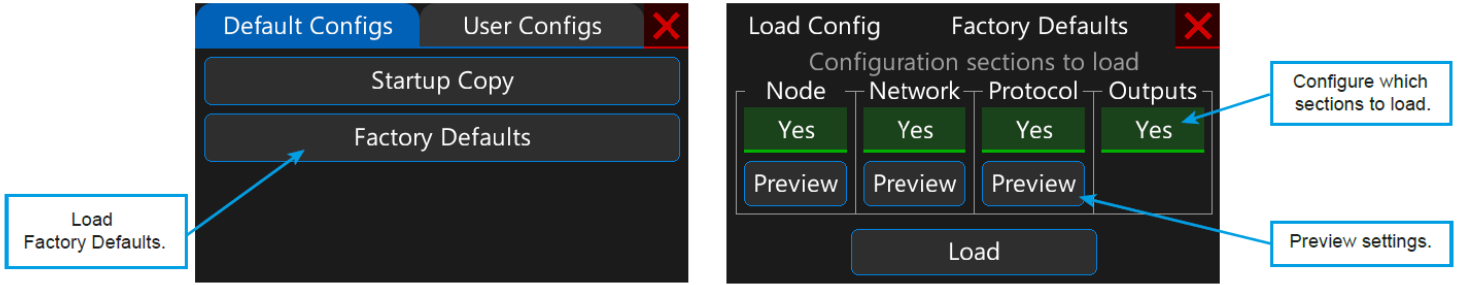

Startup Copy is a copy of the BoostBox configuration at device start-up. It can be used to restore BoostBox configuration to exactly the same state it was when the device. Preview the settings powered up.

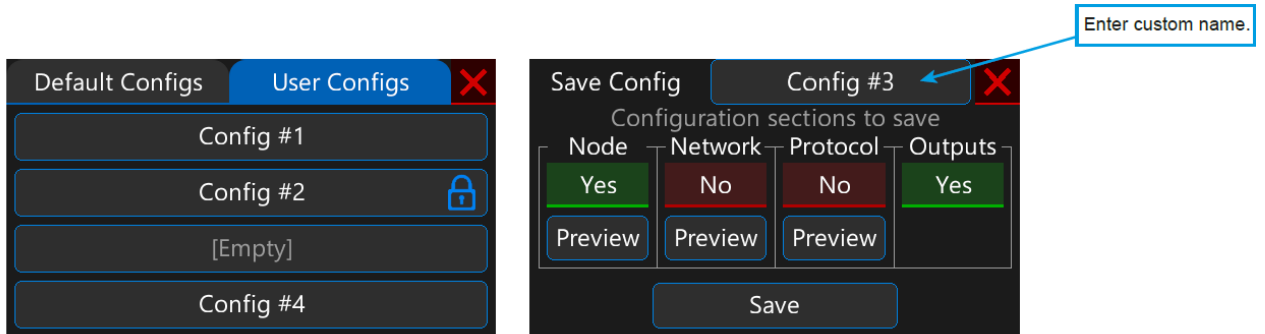

Save up to 4 different user configurations

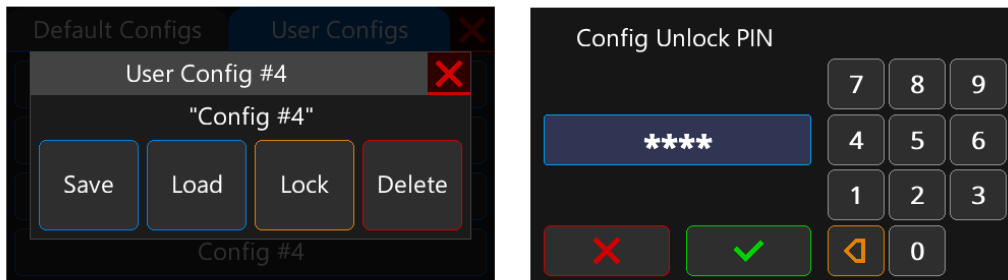

Lock the desired user configuration with 4 digit pin combination so it can not be deleted without pin entry

## Screen Lock

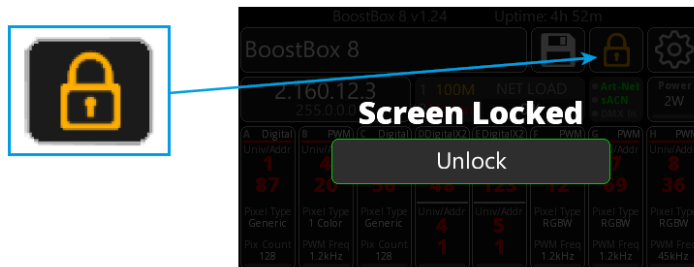

Lock will appear orange when screen is locked. Hold down Unlock button to turn off the screen lock. Screen lock is useful to not change any settings on accident.



## Config menu

### Device

The screenshot shows the 'Device' configuration menu with the following settings and callouts:

- Device Name:** BoostBox 8 (Callout: Edit name of the device)
- Universe Display Format:** Decimal (0..32767) (Callout: Display Universe in: Decimal (0..32767), Hex (0..F), Base 16 (0..15), Alpha (A..AVLG))
- Screen/LED Brightness:** Off, Dim, Full (Callout: Controls the brightness of screen and LEDs. Off- leaves the screen at dim and LEDs are off.)
- Screen Auto Lock (30s):** Disabled (Callout: Enable or disable automatic screen lock. When enabled, screen locks after 30s, if not used.)
- Touchscreen:** Calibrate (Callout: Calibrate the touchscreen by pushing the dots in given order.)
- Device Info:** Show Device Info (Callout: Real time in depth info about the device)

### Network

The screenshot shows the 'Network' configuration menu with the following settings and callouts:

- IP Address:** 2.160.12.3 (Callout: IP Address- tap to edit.)
- Subnet Mask:** 255.0.0.0 (Callout: Subnet Mask- tap to edit.)
- Easy IP:** Disabled (Callout: Enable or disable Easy IP. NOTE: In case when Easy IP setting is ON you will not be able to change the mask settings.)
- MAC Address:** 80:34:28:20:D8:DA

Easy IP setting will ensure that software will search for all masks, not only for a specified one. It's useful for most networking situations where subnet filtering isn't required. BoostBox will automatically find and output Art-Net and sACN information regardless of IP or Subnet Mask settings.

### Protocol

The screenshot shows the 'Protocol' configuration menu with the following settings and callouts:

- Protocol:** Art-Net, sACN, DMX In (Callout: Tap to Enable or Disable: Art-Net, sACN (e1.31), DMX Input)
- Source Loss Action:** Blackout (Callout: Source Loss Action select: Hold Values, Blackout)
- Source Loss Timeout:** 5 seconds (Callout: Source Loss Timeout (5-120s). How much time for Source Loss to take action, after the DMX data has been lost)
- Easy Priority 512:** Enabled (Callout: Tap to Enable or Disable Easy Priority 512)

#### Source Loss Action

When the **"Hold values"** setting is chosen, after the source DMX is lost, the BoostBox holds the last DMX values it has received and continues to output these values until incoming DMX has been restored.

When the **"Blackout"** setting is chosen, after the source DMX is lost, all DMX values will change to 0 and be held at this value until incoming DMX is restored.

When the **"Output Off"** setting is chosen, after the source DMX is lost, any DMX output will be stopped. When the DMX source is restored, BoostBox will continue outputting the source DMX.

#### What is Easy Priority ?

When two or more of the same Art-Net/ sACN universes are coming into the BoostBox, the console with the higher channel 512 on a universe value will have control over that universe.



## Outputs

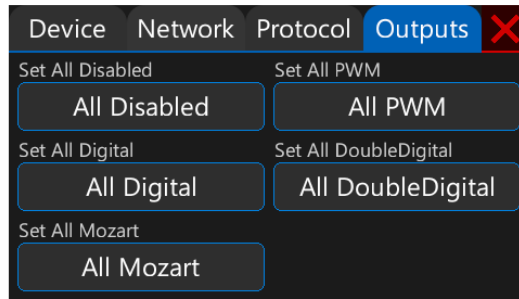

All Output ports can be configured individually, but it is also possible to **set all** ports by tapping and holding:

- Disable
- PWM
- Digital
- Double digital
- Mozart

## Power Statistics

Power Statistics				
<b>Total: 1W</b>		System Fans: 19%		
<b>4Out_1</b>	Output 1	Output 2	Output 3	Output 4
MCU: 25.1C	U: 48.0V	U: 48.0V	U: 48.0V	U: 48.0V
PSU: 32.0C	I: <0.1A	I: <0.1A	I: <0.1A	I: <0.1A
Fans: 25%	P: <1W	P: <1W	P: <1W	P: <1W
<b>4Out_2</b>	Output 5	Output 6	Output 7	Output 8
MCU: 26.9C	U: 48.0V	U: 48.0V	U: 48.0V	U: 48.0V
PSU: 32.0C	I: <0.1A	I: <0.1A	I: <0.1A	I: <0.1A
Fans: 25%	P: <1W	P: <1W	P: <1W	P: <1W

Power Statistics give real time information about each individual output and total power

# BOOSTBOX 2 NAVIGATION

## Main Screen

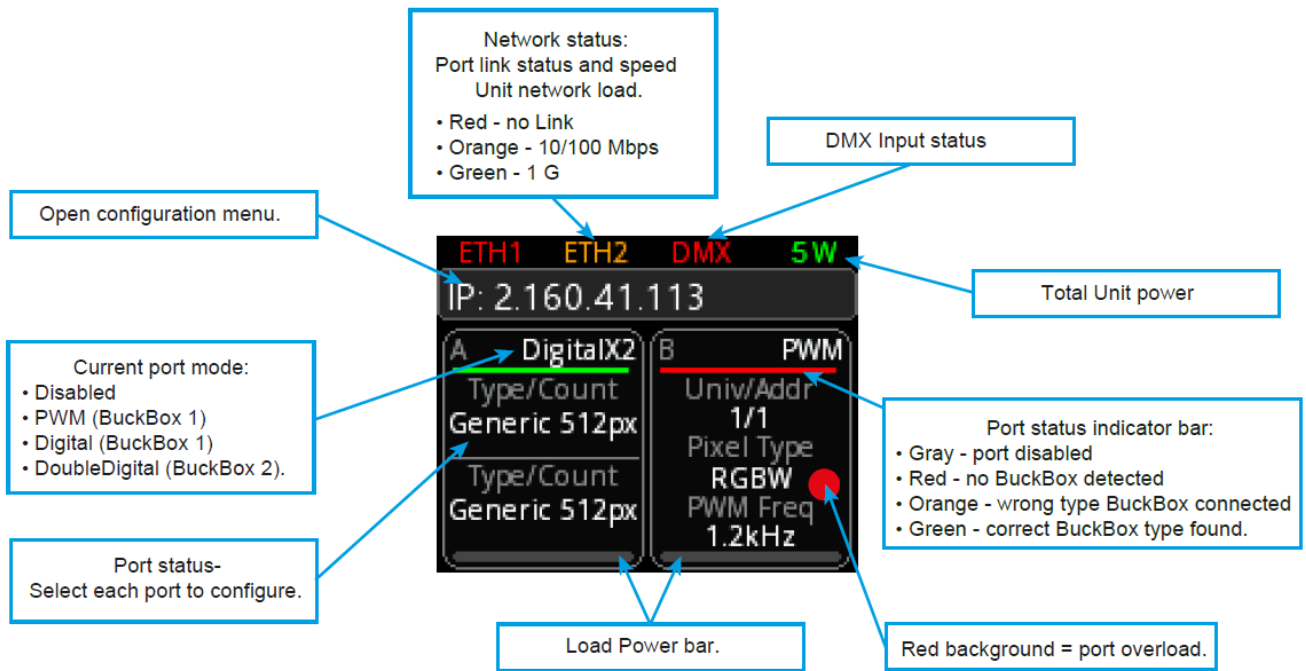

## Port Configuration - PWM

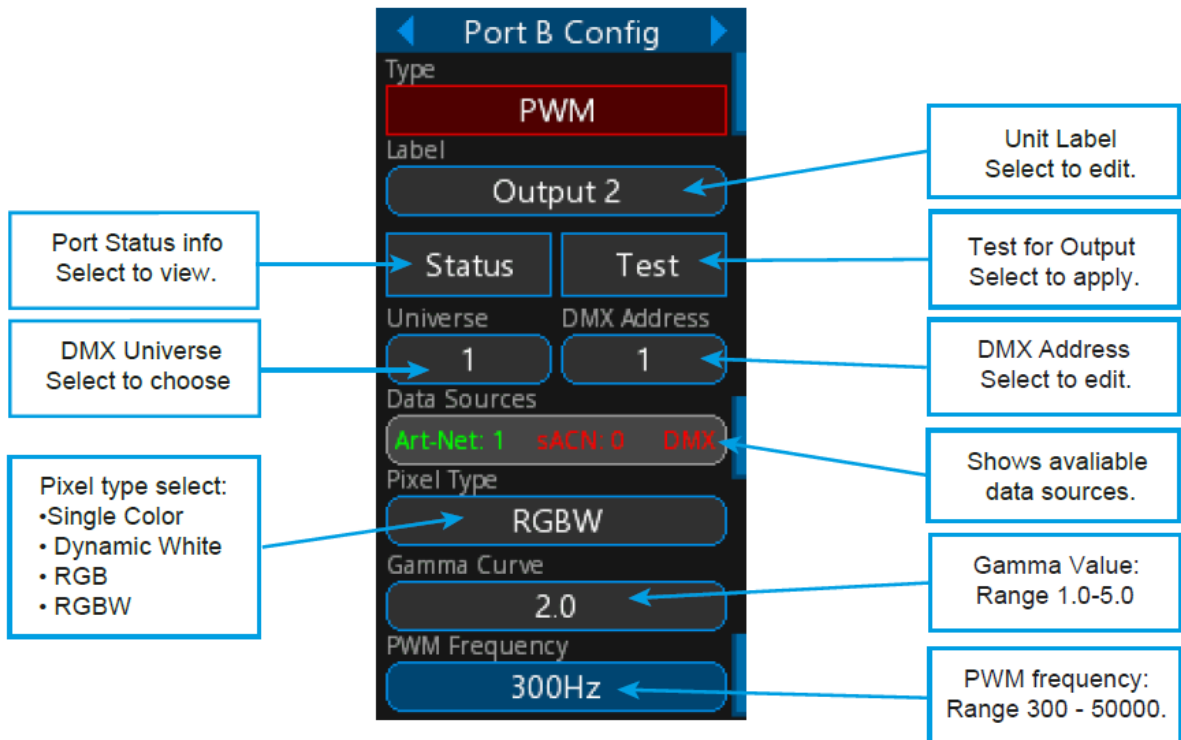

## Port Configuration - Digital

**Port B Config**

Type: Digital

Label: Output 2

Status Test

Universe #1: 1 Address #1: 1

Data Sources: Art-Net: 1 sACN: 0 DMX

Pixel Type: RGBW

Pixel Count: 32pix / 128ch

Reverse Pixel Order: No

Repeat: Yes Clone Size: 1

Mirror: Yes

Pixel Copy: Yes Copy Size: 2

**Callout Boxes:**

- Unit Label Select to edit.
- Test for Output Select to apply.
- DMX Address Select to edit.
- Shows available data sources.
- Pixel count. This is needed for pixel reversing and mirroring.
- Clone repeat - reuses data after given clone size. If set to 1, single pixel will control whole length of digital tape run.
- Pixel Copy- same input data for multiple consecutive pixels effectively reducing pixel resolution.
- Port Status info Select to view.
- DMX Universe Select to choose
- Pixel type select:
  - Single Color
  - Dynamic White
  - RGB
  - RGBW
- Reverses pixel sequence so addressing starts at the end of FloppyFlex Digital run.
- Mirrors pixel order for each section.

## Port Configuration - Mozart

**Port B Config**

Type: Mozart

Label: Output 2

Status Test

Universe: 1 DMX Address: 1

Data Sources: Art-Net: 1 sACN: 0 DMX

Pixel Type: RGBW

Pixels Per Unit: 1

Power: Normal

**Callout Boxes:**

- Unit Label Select to edit.
- Test for Output Select to apply.
- DMX Address Select to edit.
- Shows available data sources.
- Normal (20W) or High Power (40W) mode.
- Port Status info Select to view.
- DMX Universe Select to choose
- Pixel type select:
  - White/UV
  - RGB
  - RGBW.
- Pixels Per Unit (1-16)

## Port Configuration - Double Digital

Port B Config

Type: DoubleDigital

Label: Output 2

Status Test

Universe #1: 1 Address #1: 1

Data Sources #1: Art-Net: 1 sACN: 0 DMX

Pixel Type #1: RGBW

Pixel Count #1: 32pix / 128ch

Reverse Pixel Order #1: No

Repeat #1: No Clone Size #1: 1

Mirror #1: No

Pixel Copy #1: No Copy Size #1: 2

Universe #2: 2 Address #2: 1

Data Sources #2: Art-Net: 1 sACN: 0 DMX

Pixel Type #2: RGBW

Pixel Count #2: 128pix / 128ch

Reverse Pixel Order #2: No

Repeat #2: Yes Clone Size #2: 1

Mirror #2: Yes

Pixel Copy #2: Yes Copy Size #2: 2

Same parameters as for Digital (repeated for each physical output).

## Config menu

### Device

The screenshot shows the 'Device' configuration menu with the following settings and callouts:

- Node Name:** BoostBox 2. Callout: Edit name of the device.
- Universe Display Format:** Decimal (0..32767). Callout: Display Universe in: Decimal (0..32767), Hex (0..F), Base 16 (0..15), Alpha (A..AVLG).
- Screen/LED Brightness:** Full. Callout: Controls the brightness of screen and LEDs. Off- leaves the screen at dim and LEDs are off.
- Device Info:** Show Device Info. Callout: system resources statistics.

### Network

The screenshot shows the 'Network' configuration menu with the following settings and callouts:

- IP Address:** 2.160.41.113. Callout: IP Address-select to edit.
- Network Mask:** 255.0.0.0. Callout: Subnet Mask-select to edit.
- Easy IP:** Disabled. Callout: Enable or disable Easy IP. NOTE: In case when Easy IP setting is ON you will not be able to change the mask settings.
- MAC Address:** 80:34:28:20:F5:48.

### Protocol

The screenshot shows the 'Protocol' configuration menu with the following settings and callouts:

- Protocol:** Art-Net/sACN/DMX-In. Callout: Select to Enable or Disable: Art-Net, sACN (e1.31), DMX Input.
- Source Loss Action:** Blackout. Callout: Source Loss Action select: Hold Values, Blackout.
- Source Loss Timeout:** 5 seconds. Callout: Source Loss Timeout (5-120s). How much time for Source Loss to take action, after the DMX data has been lost.
- Easy Priority 512:** Enabled. Callout: Select to Enable or Disable Easy Priority 512.

### User Config

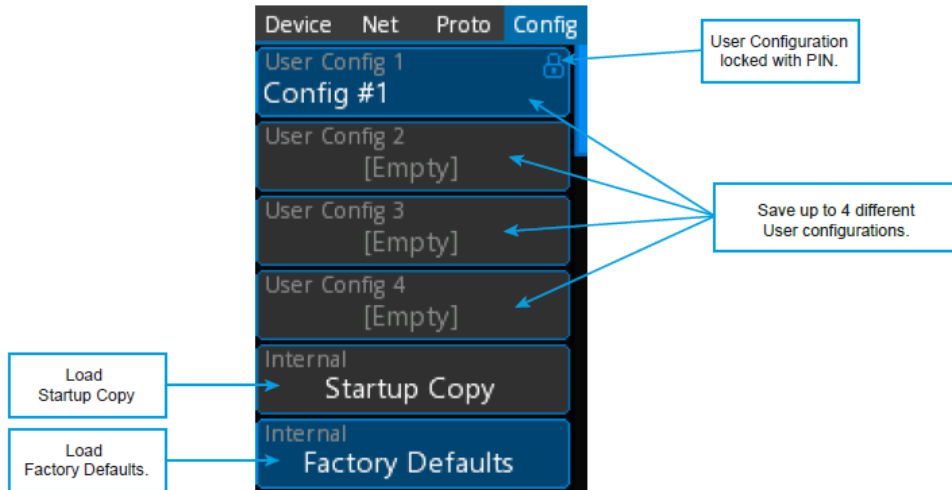

### Save Config

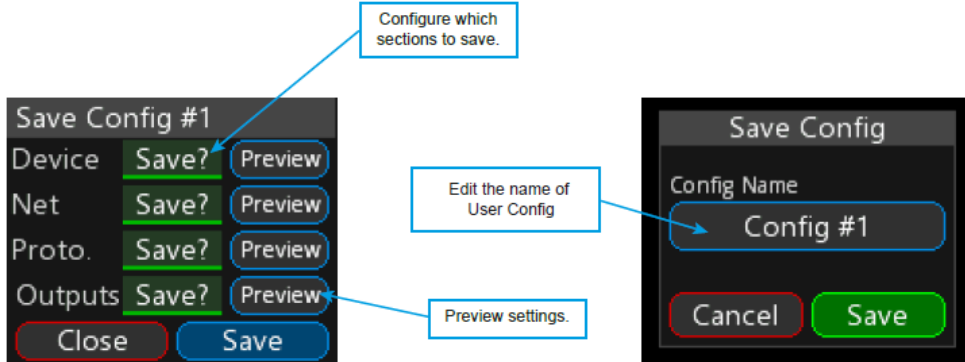

### Load/Lock Config

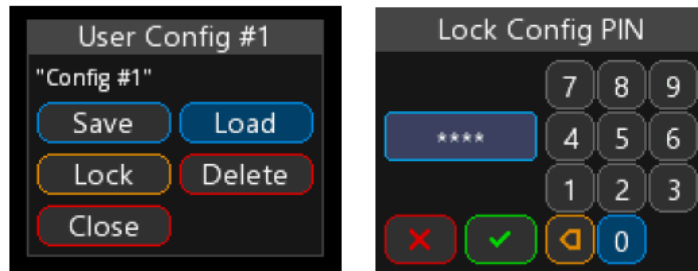

Lock the desired user configuration with 4 diget pin combination so it can not be deleted without pin entry

# MENU MAP – BOOSTBOX 8 AND BOOSTBOX 4

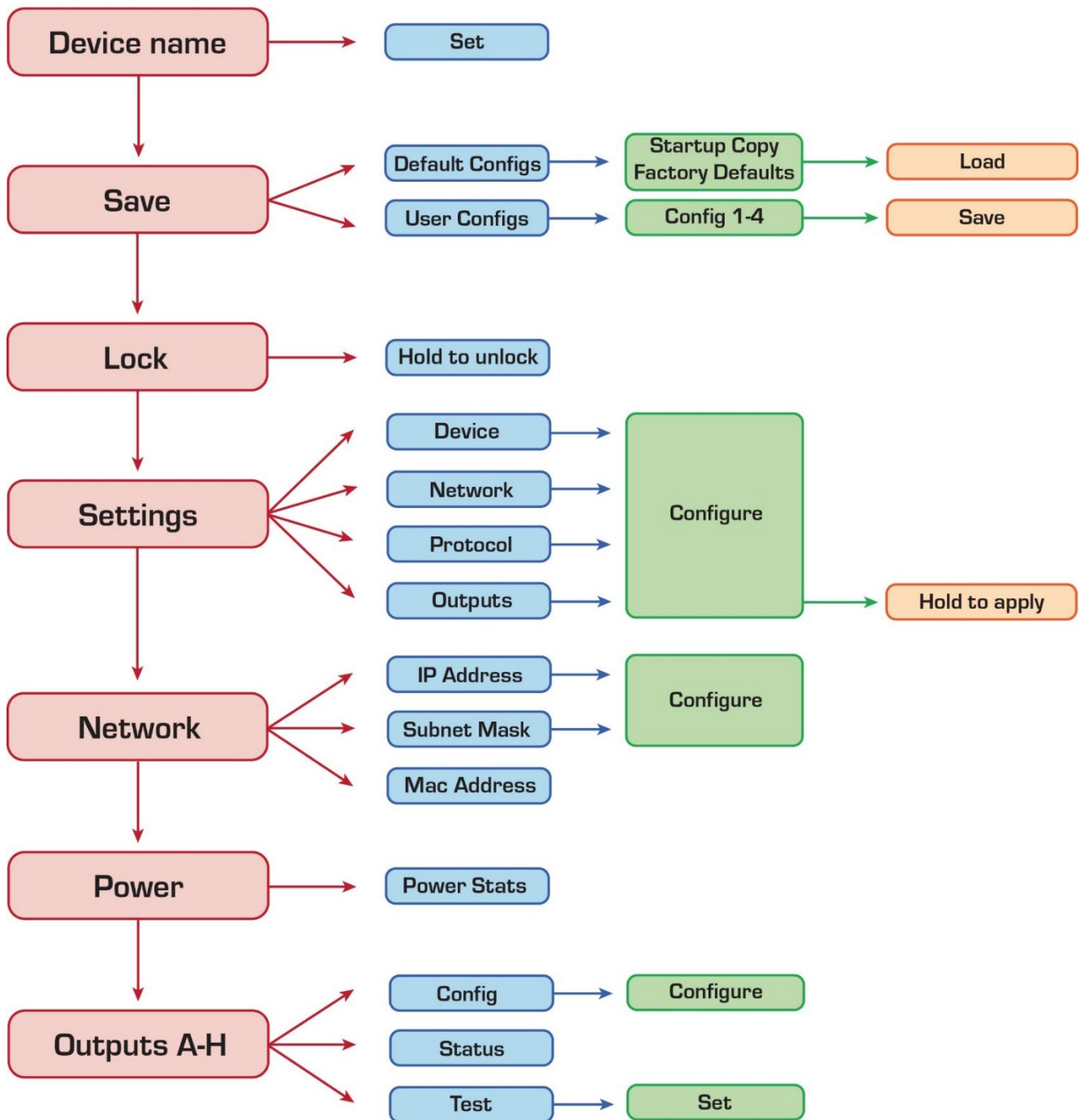



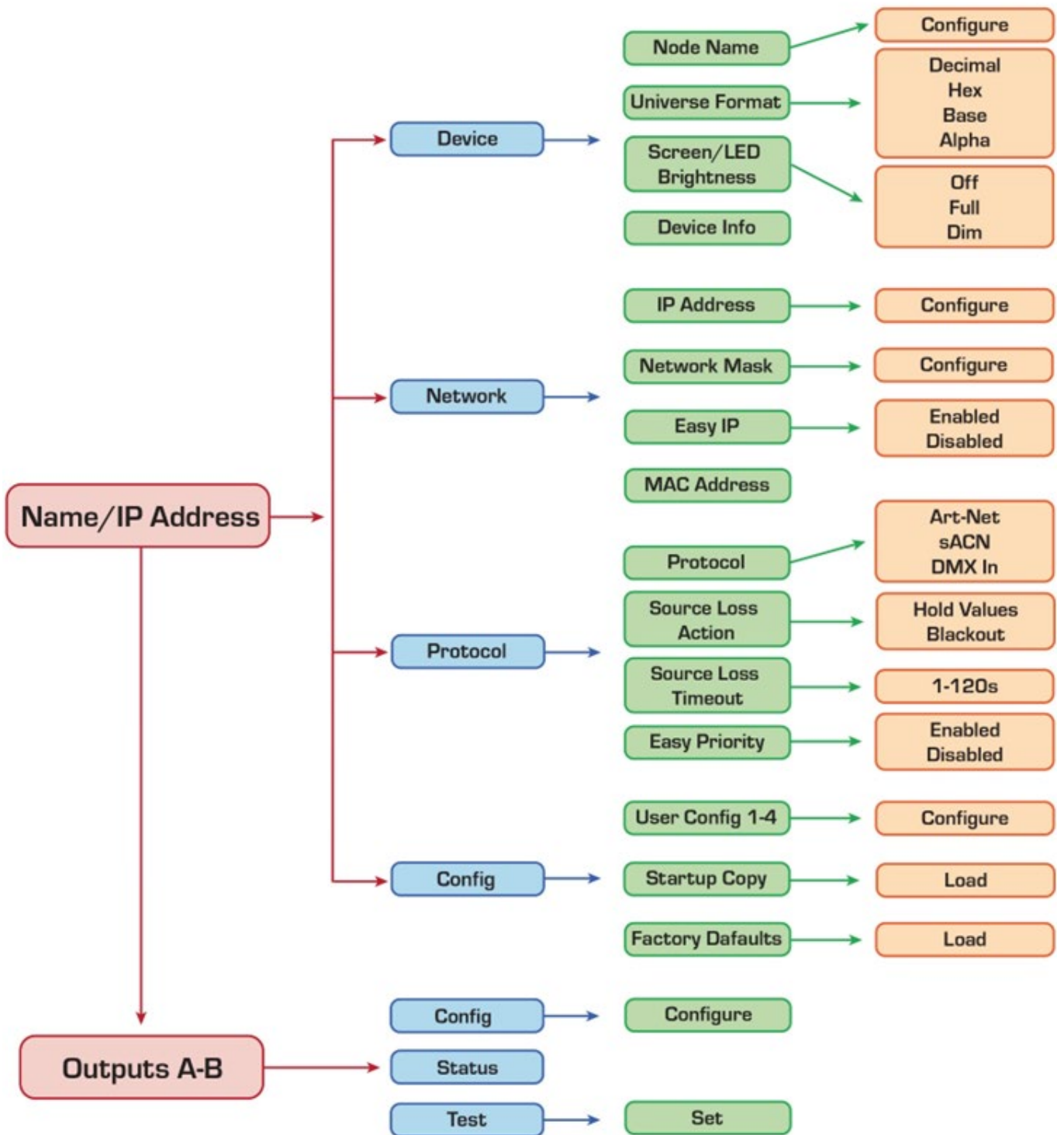

# MENU MAP – BOOSTBOX 2 AND BOOSTBOX 2 DIN





## LED INDICATORS

### Output LED

-  Device is connected
-  Device is connected but the incorrect Output type is chosen
-  No device is connected
-  Output is configured for Mozart devices
- \*  Port overload

\* (Rapid blinking)

\* If there is a hardware or software communication error, ports will alternately blink Red/Off

\* LED is Off, if the port is disabled.

\* LED pulses white when configuring a port

### BoostBox 2 DMX LED:

DIN: DMX LED toggles blue color on each received DMX packet.

### BuckBox status LED patterns:

- Always OFF - power supply disabled
- ON-blink (100ms ON, 900ms OFF) - not receiving data;
- OFF-blink (900ms ON, 100ms OFF) - receiving data;
- ON-blink twice (700ms ON, 100ms OFF, 100ms ON, 100ms OFF) - receiving data for both output ports (only applies to BuckBox 2 Digital);
- Slow toggling (1000ms ON, 1000ms OFF) - error detected.

# TECHNICAL SPECIFICATIONS

	<b>8 XLR</b>	<b>4 XLR</b>	<b>8 PTB</b>	<b>4 PTB</b>
PowerData "Booster" Outputs	8	4	8	4
Output Connector	Neutrik XLR4 Female		Pluggable Terminal Block (PTB) 5-terminal	
Ethernet Ports	2x Neutrik EtherCON RJ45 (1G)			
Network Protocols	ArtNet, sACN (E1.31)			
DMX Input	1x Neutrik XLR5 Male			
DMX Thru	1 x Neutrik XLR5 Female			
DMX control	DMX 512A+RDM			
Power	100-240V, 50-60 Hz			
Power Connector	PowerCON TRUE 1 TOP			
Max Power Consumption	2000W	1000W	2000W	1000W
Operating Temp.	-20° to +40° C			
Unit Dimensions (WxHxD)	19 x 3.47 x 12.08 in [482,6 x 88,1 x 307 mm]			

	<b>BoostBox 2</b>	<b>BoostBox 2 DIN</b>
PowerData "Booster" Outputs	2	
Output Connector	Neutrik XLR4 Female	Pluggable Terminal Block (PTB) 5-terminal
Ethernet Ports	2x Neutrik EtherCON RJ45 (100 Mbit)	2x RJ45 (100 Mbit)
Network Protocols	ArtNet, sACN (E1.31)	
DMX Input	1x Neutrik XLR5 Male	Pluggable Terminal Block (PTB) 3-terminal
DMX Thru	1 x Neutrik XLR5 Female	-
DMX control	DMX 512A+RDM	
Power	100-240V, 50-60 Hz	48V (Requires external power supply)
Power Connector	PowerCON TRUE 1 TOP	Pluggable Terminal Block (PTB) 4-terminal
Max Power Consumption	500 W	500 W
Operating Temp.	-20° to +40° C	-20° to +50° C
Unit Dimensions (WxHxD)	4.1 x 3.63 x 1.55 in [104 x 92,3 x 39,5 mm]	8.15 x 5.33 x 10.72 in [207 x 136 x 273 mm]

# PRODUCT DRAWINGS

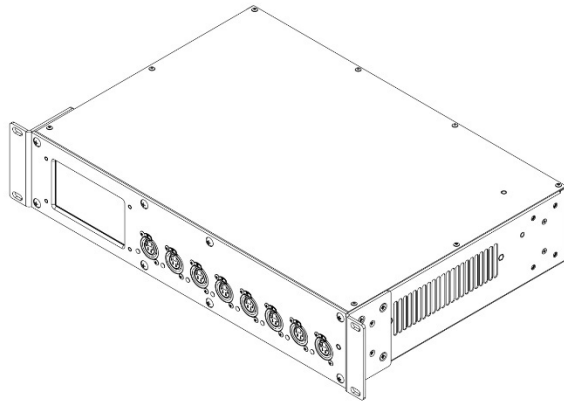
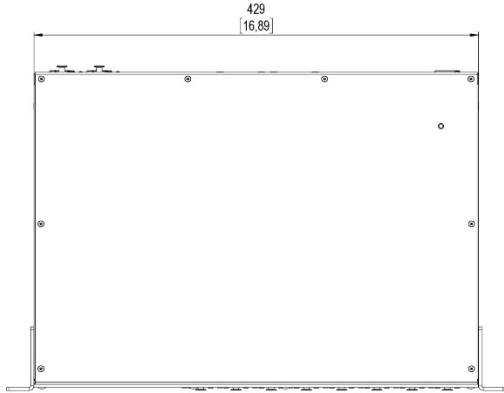
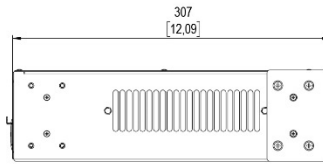
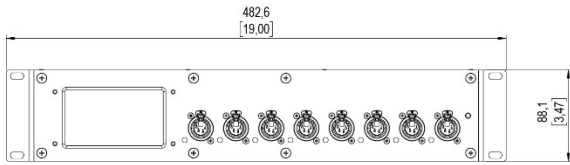

Back

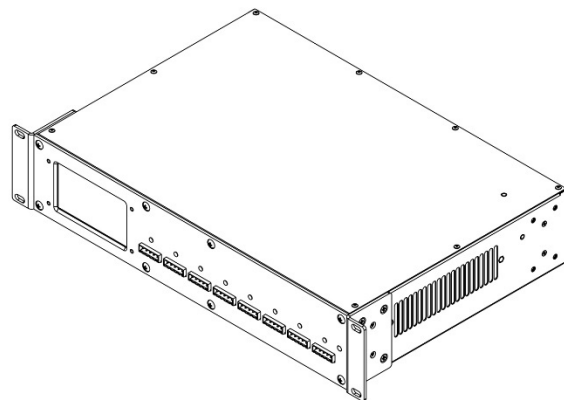
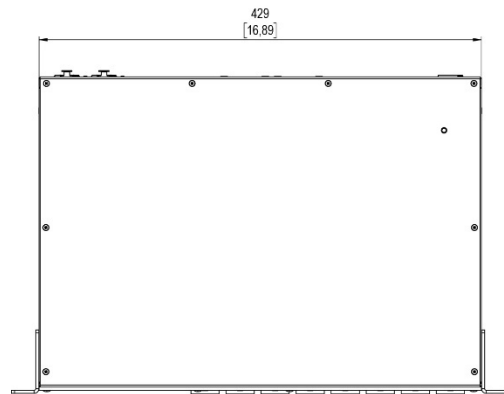
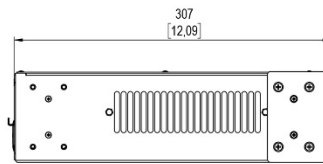
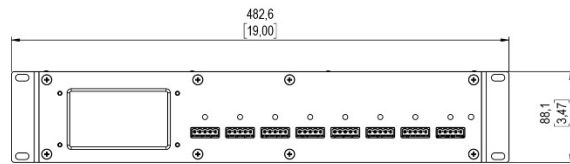

Back



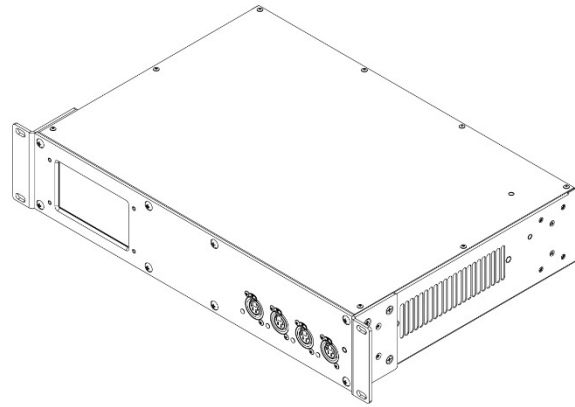
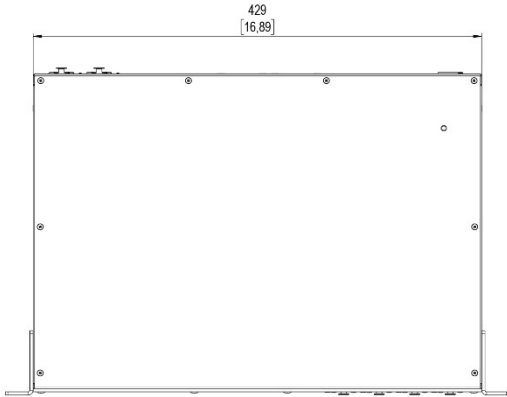
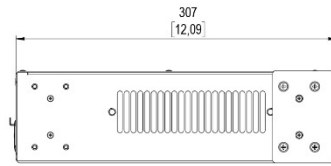
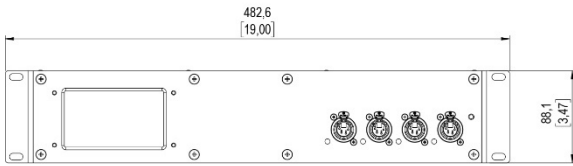

Back

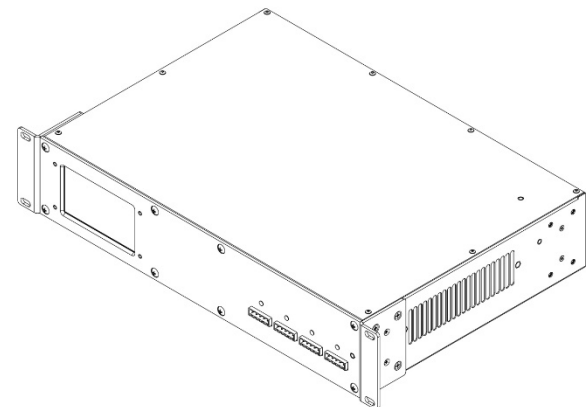
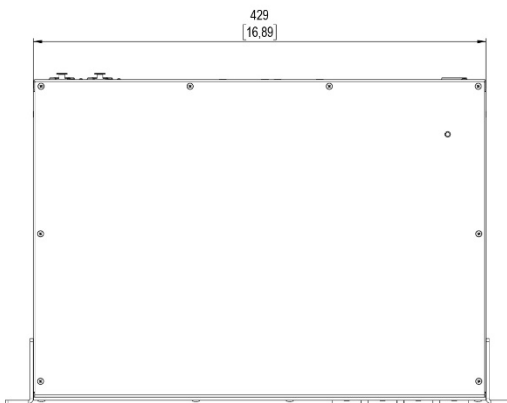
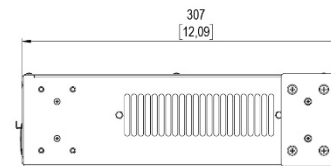
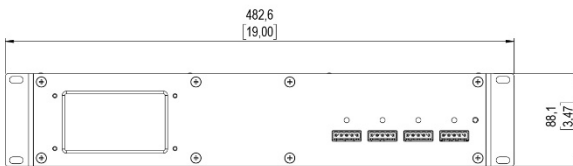

Back



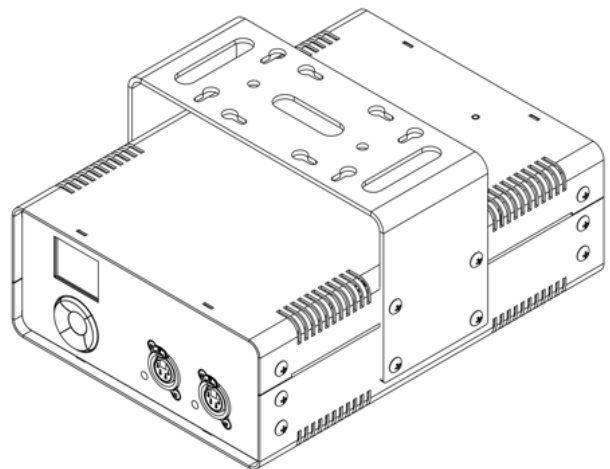
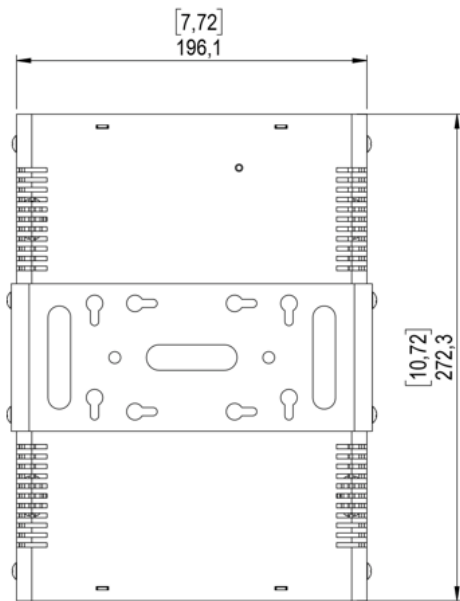
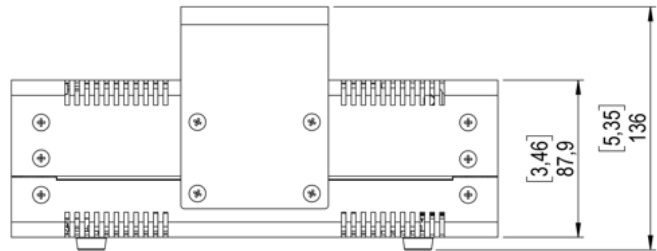
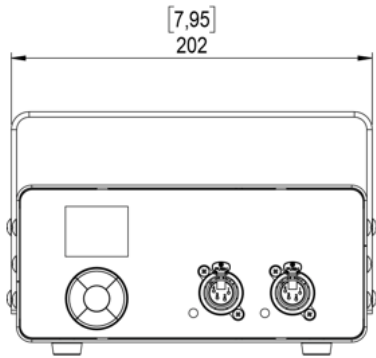

Back

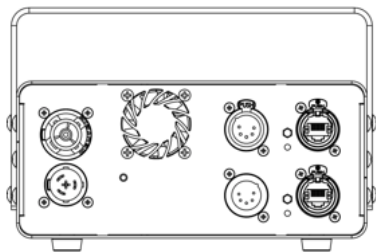

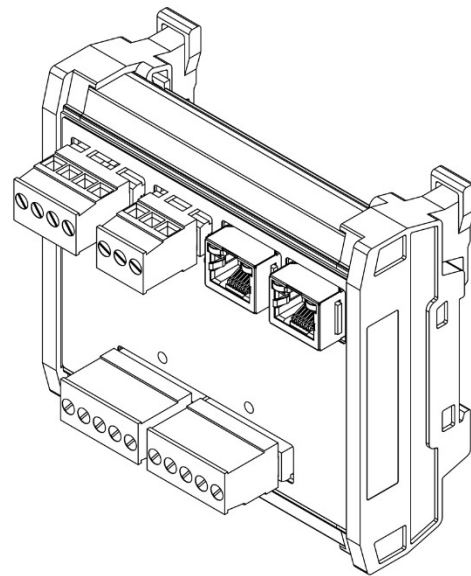
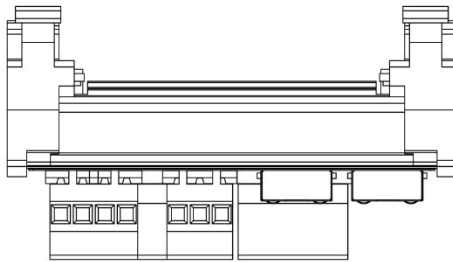
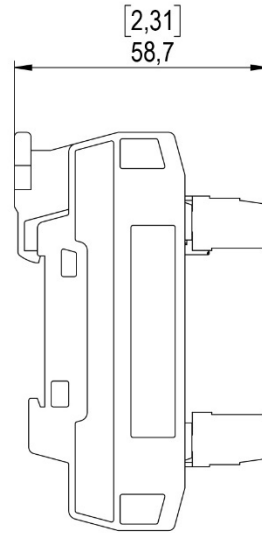
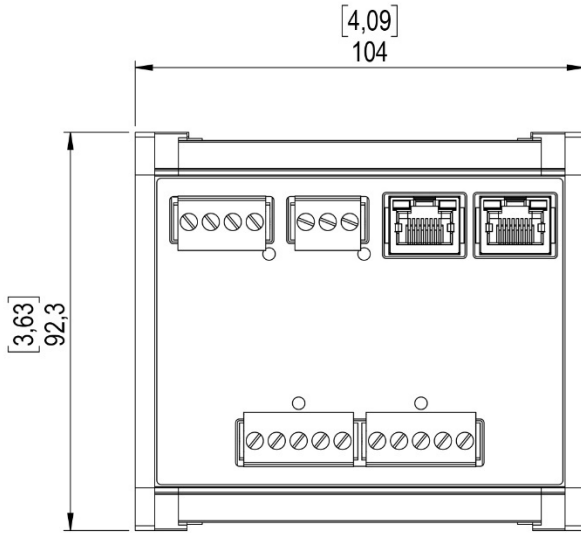

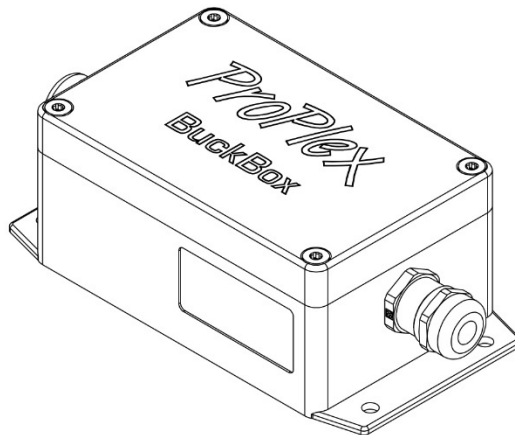
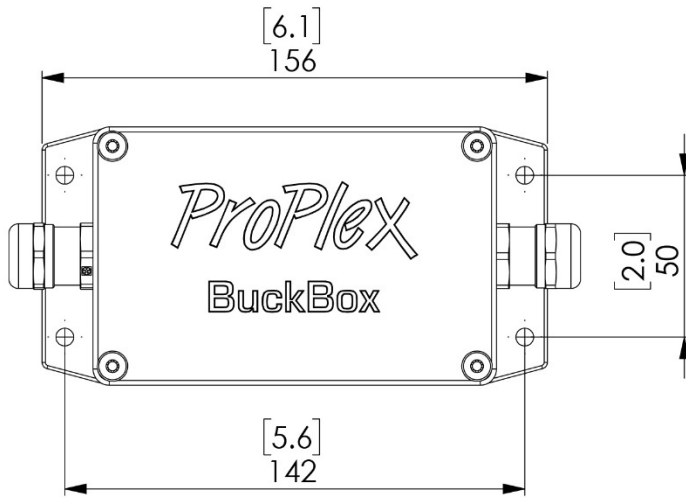
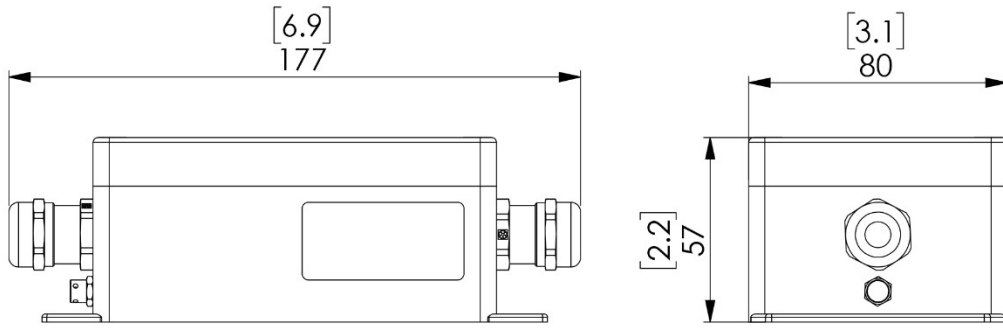

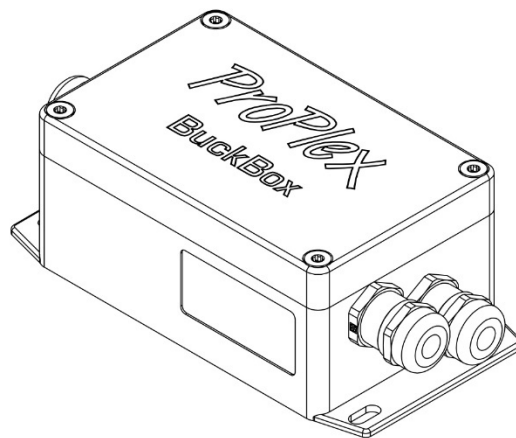
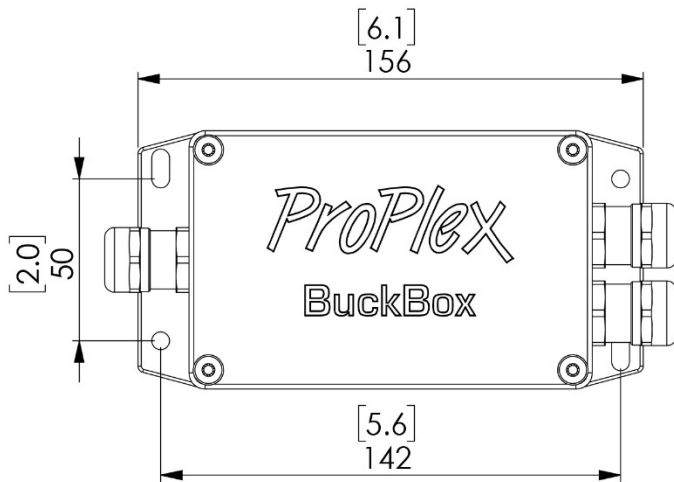
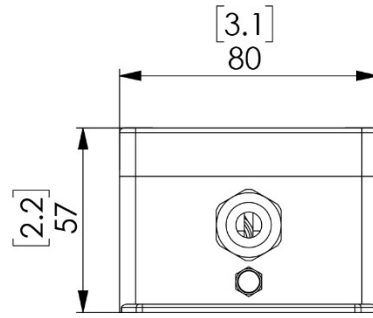
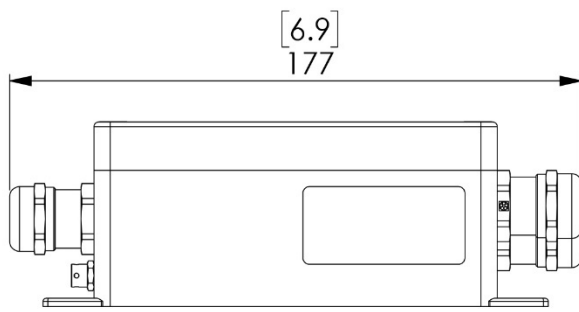



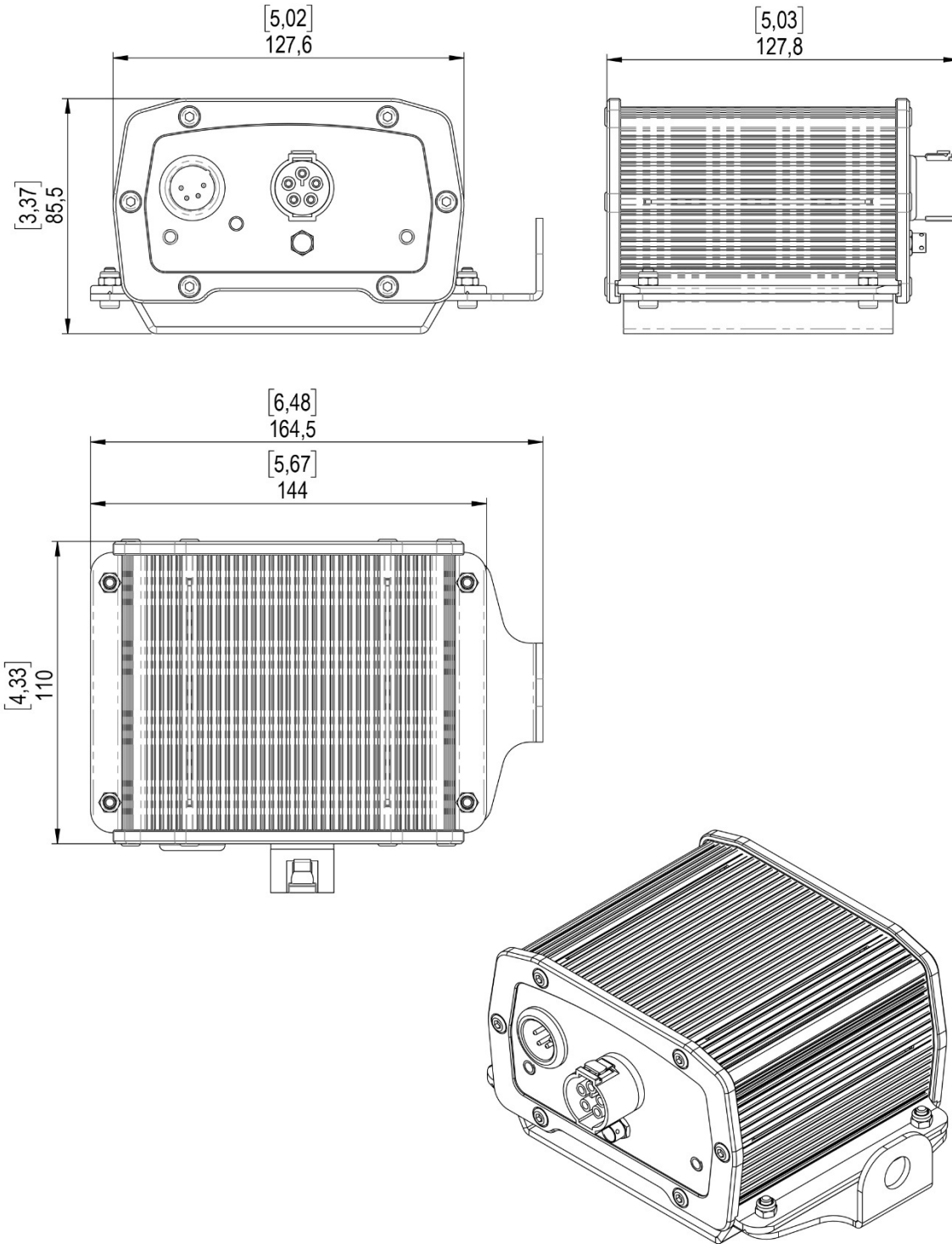

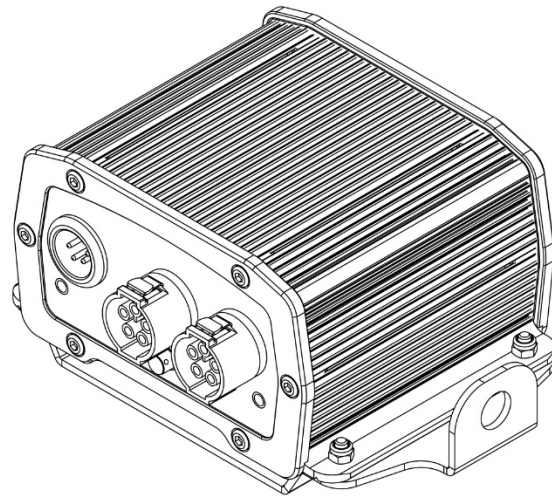
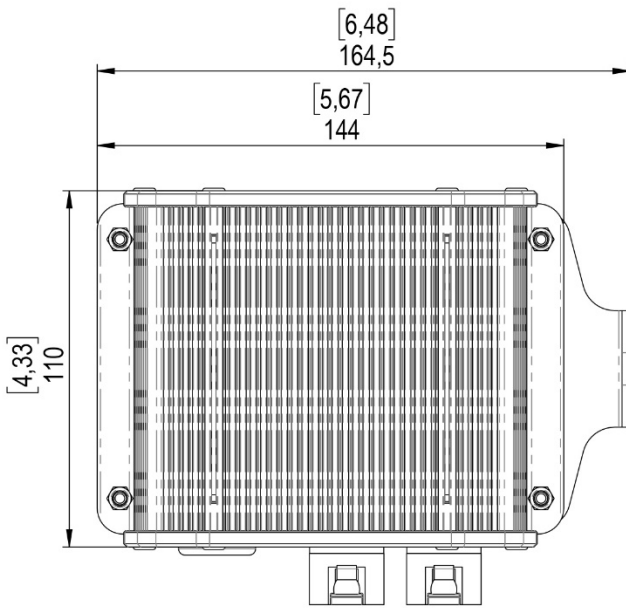
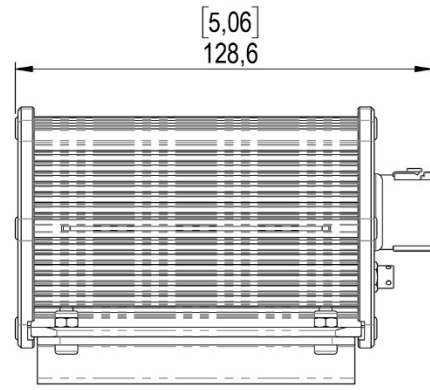
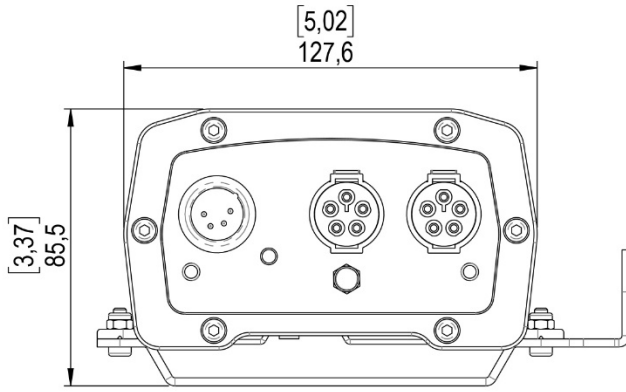

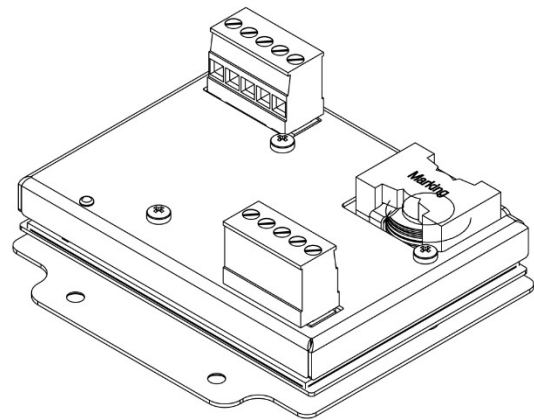
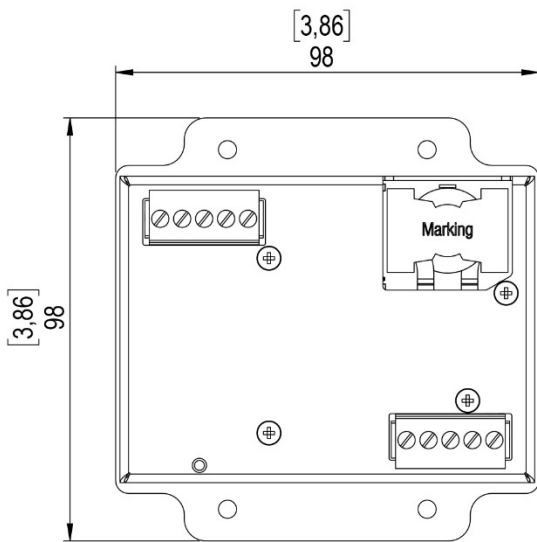
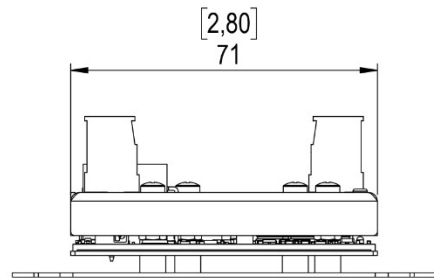
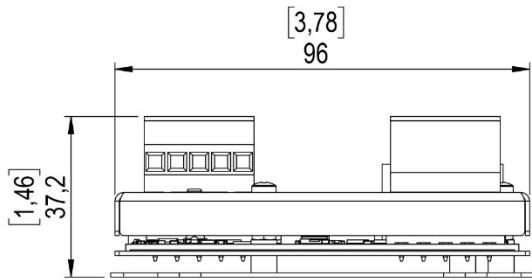

# RETURN PROCEDURE

Please send returned merchandise prepaid and in the original packing. Freight call tags will not be issued for shipping the product to TMB, but TMB will pay the freight for return to the customer. Clearly label package with a Return Merchandise Authorization Number (RMA #). Products returned without an RMA # will delay service. Please contact TMB and request an RMA # prior to shipping the unit. Be prepared to provide the model number, serial number, and a brief description of the cause for the return. Be sure to properly pack the unit; any shipping damage resulting from inadequate packaging is the customer's responsibility. TMB reserves the right to use its own discretion to repair or replace product(s). Proper UPS packing or double-boxing will better ensure product integrity when shipped.

**Note: If you are given an RMA #, please include the following information on a piece of paper inside the box:**

1. Your name
2. Your address
3. Your phone number
4. The RMA #
5. A brief description of the symptoms

# CONTACT INFORMATION

## LOS ANGELES HEADQUARTERS

527 Park Avenue | San Fernando, CA 91340, USA  
Tel: +1 818.899.8818 | Fax: +1 818.899.8813  
[sales@tmb.com](mailto:sales@tmb.com)

## TMB 24/7 TECH SUPPORT

US/Canada: +1.818.794.1286  
Toll Free: 1.877.862.3833 (1.877.TMB.DUDE)  
UK: +44 (0)20.8574.9739  
Toll Free: 0800.652.5418  
[techsupport@tmb.com](mailto:techsupport@tmb.com)

**LOS ANGELES** +1 818.899.8818

**LONDON** +44 (0)20.8574.9700

**NEW YORK** +1 201.896.8600

**BEIJING** +86 10.8492.1587

**CANADA** +1 519.538.0888

**RIGA** +371 6389 8886



A full service company providing technical support, customer service, and follow-up. Providing products and services for the industrial, entertainment, architectural, installation, defense, broadcast, research, telecommunications, and signage industries. Servicing the global market from offices in Los Angeles, London, New York, Toronto, and Beijing.