

LEDJ

Artisan 1000 RGBA Fresnel User Manual



Order code: LEDJ334

WARNING

FOR YOUR OWN SAFETY, PLEASE READ THIS USER MANUAL CAREFULLY BEFORE YOUR INITIAL START-UP!

- Before your initial start-up, please make sure that there is no damage caused during transportation.
- Should there be any damage, consult your dealer and do not use the equipment.
- To maintain the equipment in good working condition and to ensure safe operation, it is necessary for the user to follow the safety instructions and warning notes written in this manual.
- Please note that damages caused by user modifications to this equipment are not subject to warranty.



IMPORTANT:

The manufacturer will not accept liability for any resulting damages caused by the non-observance of this manual or any unauthorised modification to the equipment.

- Never let the power cable come into contact with other cables. Handle the power cable and all mains voltage connections with particular caution!
- Never remove warning or informative labels from the unit.
- Do not open the equipment and do not modify the unit.
- Do not connect this equipment to a dimmer pack.
- Do not switch the equipment on and off in short intervals, as this will reduce the system's life.
- Only use the equipment indoors.
- Do not expose to flammable sources, liquids or gases.
- Always disconnect the power from the mains when equipment is not in use or before cleaning! Only handle the power-cable by the plug. Never pull out the plug by pulling the power-cable.
- Make sure that the available mains supply voltage is between 100~240V AC, 50/60Hz.
- Make sure that the power cable is never crimped or damaged. Check the equipment and the power cable periodically.
- If the equipment is dropped or damaged, disconnect the mains power supply immediately and have a qualified engineer inspect the equipment before operating again.
- If the equipment has been exposed to drastic temperature fluctuation (e.g. after transportation), do not connect power or switch it on immediately. The arising condensation might damage the equipment. Leave the equipment switched off until it has reached room temperature.
- If your product fails to function correctly, stop use immediately. Pack the unit securely (preferably in the original packing material), and return it to your Pro Light dealer for service.
- Only use fuses of same type and rating.
- Repairs, servicing and power connection must only be carried out by a qualified technician. THIS UNIT CONTAINS NO USER SERVICEABLE PARTS.
- This lighting fixture is for professional use only - it is not designed for or suitable for household use. The product must be installed by a qualified technician in accordance with local territory regulations. The safety of the installation is the responsibility of the installer. The fixture presents risks of severe injury or death due to fire hazards, electric shock and falls.
- Warning! Risk Group 2 LED product according to EN 62471. Do not view the light output with optical instruments or any device that may concentrate the beam.
- WARRANTY: One year from date of purchase.

OPERATING DETERMINATIONS

If this equipment is operated in any other way, than those described in this manual, the product may suffer damage and the warranty becomes void. Incorrect operation may lead to danger e.g: short-circuit, burns and electric shocks etc.

Do not endanger your own safety and the safety of others!

Incorrect installation or use can cause serious damage to people and/or property.

Please note: These fixtures are intended for stage lighting and entertainment applications only, and are not intended for extended periods of use, including but not limited to house-light, industrial or architectural applications and should only be operated with short duty cycles.

Artisan 1000 RGBA Fresnel

The Artisan 1000 RGBA Fresnel with a 100W quad-colour COB LED is ideal for schools, churches and stages and making it an ideal replacement for tungsten fixtures. The beam angle is manually adjustable, with all other features being controllable via the 4 button menu and OLED display or by DMX. The USB socket on the back panel allows for an optional W-DMX compatible transceiver, further expanding the fixtures versatility with wireless master/slave or DMX control.

- 1 x 100W quad-colour COB LED (RGBA)
- Manually adjustable beam angle: 15° - 45°
- 15° - 9,396 Lux @ 2m (full on), 45° - 1,985 Lux @ 2m (full on)
- Refresh rate: 1.2kHz, 2.4kHz, 4kHz, 6kHz or 10kHz selectable
- DMX channels: 4/5/6 or 8 selectable
- Artisan Series W-DMX USB compatibility for wireless master/slave or DMX control
- Artisan Series W-DMX USB can be used to receive wireless DMX and relay the DMX signal via the XLR output
- 0-100% dimming
- 4 dimming curves: Linear, square law, inverse square law and S-curve
- Variable strobe
- 4 push button menu with OLED display
- PowerCON input/output
- 5-Pin XLR input/output
- Temperature controlled fan for whisper quiet operation
- Handle on rear panel
- Filter frame and barn doors included



Specifications	Artisan 1000 RGBA Fresnel
Power consumption	105W
Power supply	100~240V, 50/60Hz
Fuse	T3A 250V
Noise Level	55dBA @ 2m
Dimensions	300 x 300 x 304mm
Weight	4.1kg
Order code	LEDJ334

15° - Lux						
FULL ON	37584	9396	4176	2349	1503	
R	12632	3158	1404	790	505	
G	20012	5003	2224	1251	801	
B	4972	1243	553	311	199	
A	13532	3383	1504	846	541	
45° - Lux						
FULL ON	7940	1985	882	496	318	
R	2360	590	262	148	94	
G	4164	1041	463	260	167	
B	1088	272	121	68	44	
A	2736	684	304	171	109	

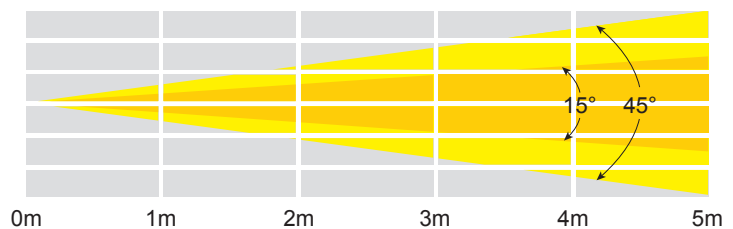

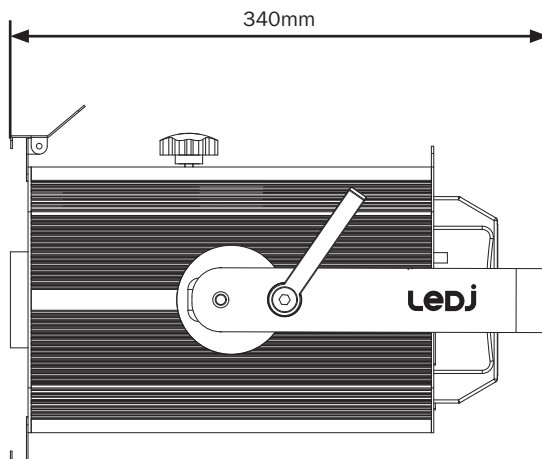
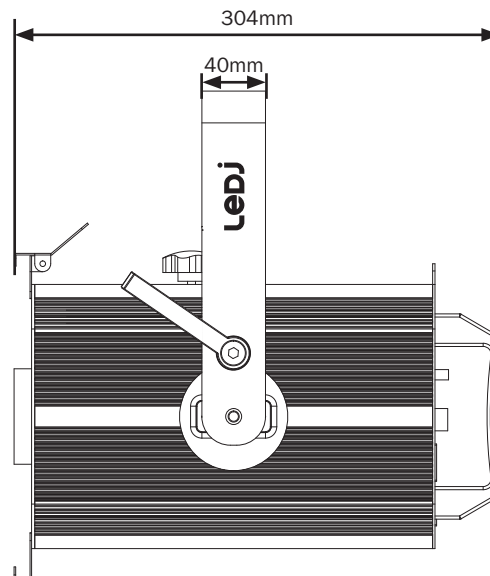
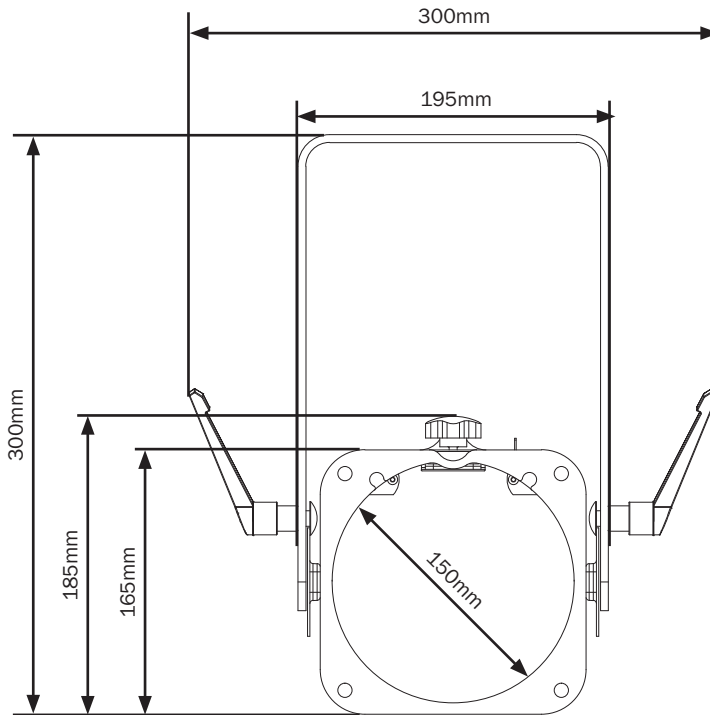

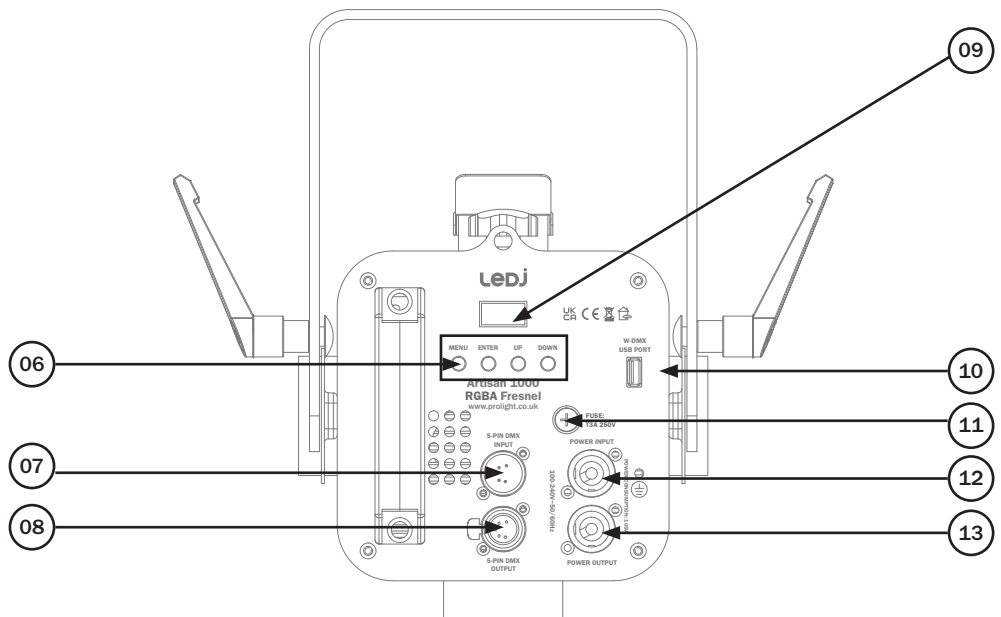
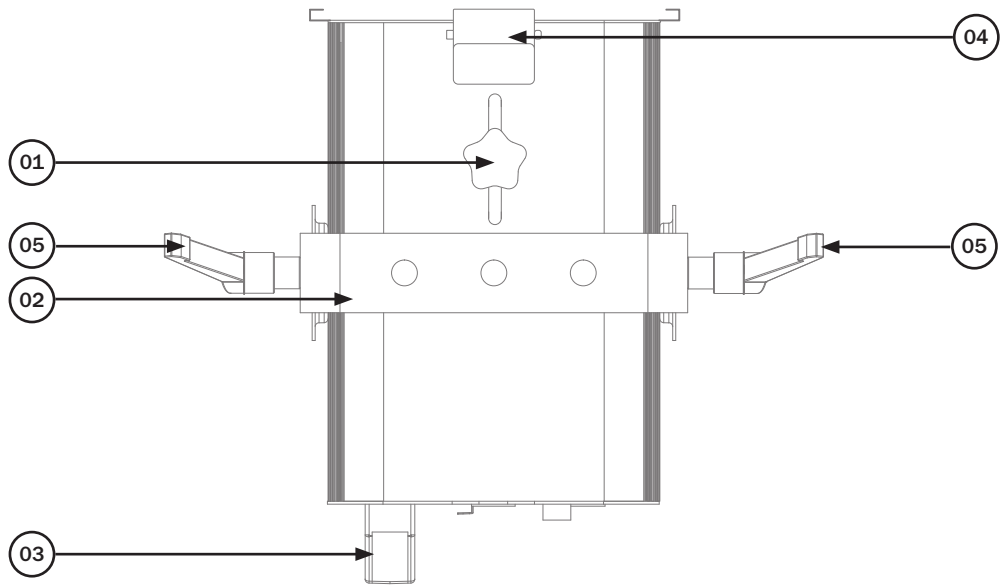

- 01 - Zoom adjustment
- 02 - Hanging bracket
- 03 - Carry handle
- 04 - Filter frame release mechanism
- 05 - Hanging bracket adjustable knobs
- 06 - Function buttons
- 07 - 5-Pin DMX input

- 08 - 5-Pin DMX output
- 09 - LED display
- 10 - Wireless DMX USB input
- 11 - Fuse: T3A 250V
- 12 - PowerCON input
- 13 - PowerCON output

In the box: **1 x fixture,**
1 x barn doors,
1 x filter frame &
1 x power cable

Main Menu	Sub Menu	Options/Values (Default Settings in BOLD)	Secondary Options/Values (Default Settings in BOLD)
DMX Settings	DMX Address	001 -512	
	DMX Channel Mode	4CH	
		5CH	
		6CH	
		8CH	
	No DMX Status	Hold Last	
		Blackout	
Manual Settings			
Internal Programs			
Personality	Primary	ON/ OFF	
	Secondary	ON/ OFF	
	Dim Modes	LED	
		HALOGEN	
	Dim Curve	Linear	
		Square	
		Inv.Squa	
		S.Curve	
	Wireless	ON/ OFF	
	LED Refresh	1200hz, 2400hz, 4000hz, 6000hz, 10000hz	
Display	Saver Delay	OFF, 1- 10 seconds	
	Menu Lock	OFF - 30 seconds , 2-10 minutes	
	Rotate Display 180°	YES/ NO	
Factory Restore	YES/ NO		
Manual	Red	000-255	
	Green	000-255	
	Blue	000-255	
	Amber	000-255	
	Colour Macros	000-023	
	Colour Temperature	2500K, 2800K,.....10000K	
	Strobe	000-255	
	Master Dimmer	000-255	

Display unlock:

To unlock the display, simply press and hold the **MENU** button for 3 seconds.

Alternatively, when the display lock setting is set to **OFF**, the display screen will never automatically lock. However, it can still be manually locked by pressing and holding the **MENU** button for 2 seconds.

To unlock, press and hold the **MENU** button for 3 seconds.

Main Menu	Sub Menu	Options/Values (Default Settings in BOLD)	Secondary Options/Values (Default Settings in BOLD)
Internal Programs	Program 0	Speed	001-255
		Fade	000-255
	Program 1	Speed	001-255
		Fade	000-255
	Program 2	Speed	001-255
		Fade	000-255
	Program 3	Speed	001-255
		Fade	000-255
	Program 4	Speed	001-255
		Fade	000-255
	Program 5	Speed	001-255
		Fade	000-255
	Program 6	Speed	001-255
		Fade	000-255
	Program 7	Speed	001-255
		Fade	000-255
	Program 8	Speed	001-255
		Fade	000-255
	Program 9	Speed	001-255
		Fade	000-255
	Program 10	Speed	001-255
		Fade	000-255
	Program 11	Speed	001-255
		Fade	000-255
	Program 12	Speed	001-255
		Fade	000-255
Program 13	Speed	001-255	
	Fade	000-255	
Information	LED Temperature	xxx F/ xxx C	
	Software Version	x.xx	
	Fixture Hours	xxxxx3H	

4 channel mode:

Channel	Value	Function
1	000-255	Red Dimmer (0-100%)
2	000-255	Green Dimmer (0-100%)
3	000-255	Blue Dimmer (0-100%)
4	000-255	Amber Dimmer (0-100%)

5 channel mode:

Channel	Value	Function
1	000-255	Red Dimmer (0-100%)
2	000-255	Green Dimmer (0-100%)
3	000-255	Blue Dimmer (0-100%)
4	000-255	Amber Dimmer (0-100%)
5	000-255	Master Dimmer (0-100%)

6 channel mode:

Channel	Value	Function
1	000-255	Red Dimmer (0-100%)
2	000-255	Green Dimmer (0-100%)
3	000-255	Blue Dimmer (0-100%)
4	000-255	Amber Dimmer (0-100%)
5	Colour Temperature	
	000-015	No Function
	016-031	2500K
	032-047	2800K
	048-063	3100K
	064-079	3400K
	080-095	3800K
	096-111	4200K
	112-127	4500K
	128-143	4800K
	144-159	5100K
	160-175	5600K
	176-191	6200K
	192-207	7000K
208-223	7800K	
224-239	8900K	
240-255	10000K	
6	000-255	Master Dimmer (0-100%)

8 channel mode:

Channel	Value	Function
1	000-255	Red Dimmer (0-100%)
2	000-255	Green Dimmer (0-100%)
3	000-255	Blue Dimmer (0-100%)
4	000-255	Amber Dimmer (0-100%)
5	000-255	Master Dimmer (0-100%)
6	Colour Macros	
	000-005	No function
	006-010	Colour 1
	011-015	Colour 2
	016-020	Colour 3
	021-025	Colour 4
	026-030	Colour 5
	031-035	Colour 6
	036-040	Colour 7
	041-045	Colour 8
	046-050	Colour 9
	051-055	Colour 10
	056-060	Colour 11
	061-065	Colour 12
	066-070	Colour 13
	071-075	Colour 14
	076-080	Colour 15
	081-085	Colour 16
	086-090	Colour 17
	091-095	Colour 18
	096-100	Colour 19
	101-105	Colour 20
	106-110	Colour 21
	111-111	Colour 22
	116-120	Colour 23
	121-125	Colour 24
	126-130	Colour 25
	131-135	Colour 26
	136-140	Colour 27
	141-145	Colour 28
	146-150	Colour 29
	151-155	Colour 30
	156-160	Colour 31
161-165	Colour 32	
166-170	Colour 33	

Channel	Value	Function
	171-175	Colour 34
	176-180	Colour 35
	181-185	Colour 36
	186-190	Colour 37
	191-195	Colour 38
	196-200	Colour 39
	201-205	Colour 40
	205-210	Colour 41
	211-215	Colour 42
	216-220	Colour 43
	221-225	Colour 44
	226-230	Colour 45
	231-235	Colour 46
	236-240	Colour 47
	241-245	Colour 48
	246-250	Colour 49
251-255	Colour 50	
7	121-140	Square Halogen
	141-160	Inv. Squa Halogen
	161-180	S. Curve Halogen
	181-255	Default to Unit Setting
8	Refresh Rates	
	000-020	Default to Unit Setting
	021-040	1200Hz
	041-060	2400Hz
	061-080	4000Hz
	081-100	6000Hz
	101-120	10000Hz
	121-255	Default to Unit Setting

Wireless operation:

To operate the fixture wirelessly you will need to plug in the Artisan Series W-DMX Compatible Transceiver (sold separately) into the USB port on the rear of the fixture. Wireless should also be set to **“ON”** in the fixtures settings (this can be found on page 6).

If using it in wireless DMX mode a compatible wireless DMX Transmitter (e.g. Wireless Solutions Sweden W-DMX Micro F-1 Lite G5 Transceiver) will need to be connected.

The Artisan Series W-DMX Compatible Transceiver features 2 operating protocols as listed below. The LED on the side of the dongle will illuminate a different colour for each operating protocol.

W-DMX G3 Transmit Protocol - Blue (when transmitting)

W-DMX Receive Protocol - Green (when receiving)

To set the dongle in one of these modes plug the Artisan Series W-DMX Compatible Transceiver into the USB port on the rear of the fixture. Hold down the button on the dongle whilst powering on the unit. The LED will illuminate white for a brief moment and then change colour. You can then press the button which will scroll through the operating protocols. Once you have selected the chosen protocol, press and hold the button on the dongle for 3 seconds. The LED will illuminate white, then turn blue (transmit mode) or stay white (receive mode). The unit is now set in your chosen protocol.

**W-DMX G3 Transmit Protocol:**

Once in this protocol the LED will illuminate blue. This indicates the fixture is ready to pair with the receiver(s). Once all the receiver(s) have been set up press the button on the dongle once and the LED will flash blue quickly, this indicates it is attempting to pair with the receivers. Once pairing is complete the LED will illuminate static blue to indicate the fixture is transmitting signal.

To disconnect the transmitting fixture from all receiving fixtures within range when connected, hold the button on the transmitting fixtures dongle down for 3 seconds until the LED illuminates red.

This indicates the wireless memory has been cleared.

W-DMX Receive Protocol:

Once in this protocol the LED will illuminate white. This indicates a connection has not yet been established with the transmitter. Once the transmitter has been set up press the button on the transmitter fixtures dongle once or press the pair button on your wireless transceiver. The LED on the receiving units will flash green quickly, this indicates it is attempting to pair with the transmitter. Once pairing is complete the LED will illuminate static green to indicate the fixture is receiving signal.

To disconnect the transmitting fixture from all receiving fixtures within range when connected, hold the button on the transmitting fixtures dongle down for 3 seconds until the LED illuminates white.

This indicates the wireless memory has been cleared.

If the indicator on the receiving units flashes red quickly this indicates that the signal from the transmitting fixture has been lost.

Setting the DMX address:

The DMX mode enables the use of a universal DMX controller. Each fixture requires a “start address” from 1- 512. A fixture requiring one or more channels for control begins to read the data on the channel indicated by the start address. For example, a fixture that occupies or uses 7 channels of DMX and was addressed to start on DMX channel 100, would read data from channels: 100, 101, 102, 103, 104, 105 and 106. Choose a start address so that the channels used do not overlap. E.g. the next unit in the chain starts at 107.

DMX 512:

DMX (Digital Multiplex) is a universal protocol used as a form of communication between intelligent fixtures and controllers. A DMX controller sends DMX data instructions from the controller to the fixture. DMX data is sent as serial data that travels from fixture to fixture via the DATA “IN” and DATA “OUT” XLR terminals located on all DMX fixtures (most controllers only have a data “out” terminal).

DMX linking:

DMX is a language allowing all makes and models of different manufactures to be linked together and operate from a single controller, as long as all fixtures and the controller are DMX compliant. To ensure proper DMX data transmission, when using several DMX fixtures try to use the shortest cable path possible. The order in which fixtures are connected in a DMX line does not influence the DMX addressing. For example; a fixture assigned to a DMX address of 1 may be placed anywhere in a DMX line, at the beginning, at the end, or anywhere in the middle. When a fixture is assigned a DMX address of 1, the DMX controller knows to send DATA assigned to address 1 to that unit, no matter where it is located in the DMX chain.

DATA cable (DMX cable) requirements (for DMX operation):

This fixture can be controlled via DMX-512 protocol. The DMX address is set on the back of the unit. Your unit requires either a standard 3-pin or 5-pin XLR connector for data input/output, see images below.

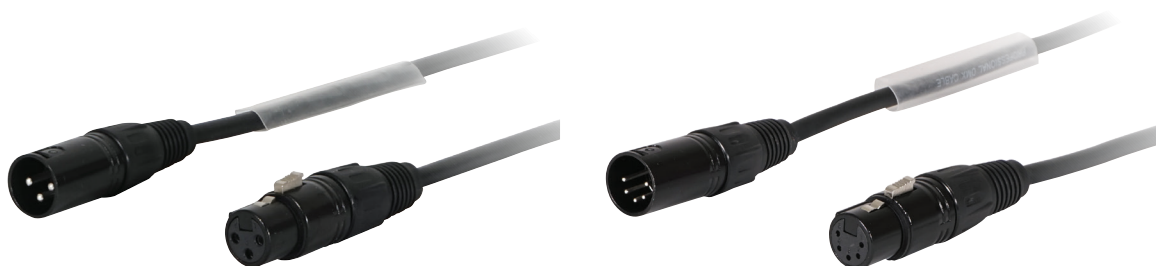

Further DMX cables can be purchased from all good sound and lighting suppliers or Prolight Concepts dealers.

Please quote:	3-Pin:	CABL10 - 2m	CABL11 - 5m	CABL12 - 10m
	5-Pin:	CABL185 - 2m	CABL187 - 5m	CABL188 - 10m

Also remember that DMX cable must be daisy chained and cannot be split.

Notice:

Be sure to follow the diagrams below when making your own cables. Do not connect the cables shield conductor to the ground lug or allow the shield conductor to come in contact with the XLRs outer casing. Grounding the shield could cause a short circuit and erratic behaviour.

Pin Configuration	
3-Pin	5-Pin
	Pin 1 - Ground
	Pin 2 - Negative
	Pin 3 - Positive
-	Pin 4 - N/C
-	Pin 5 - N/C

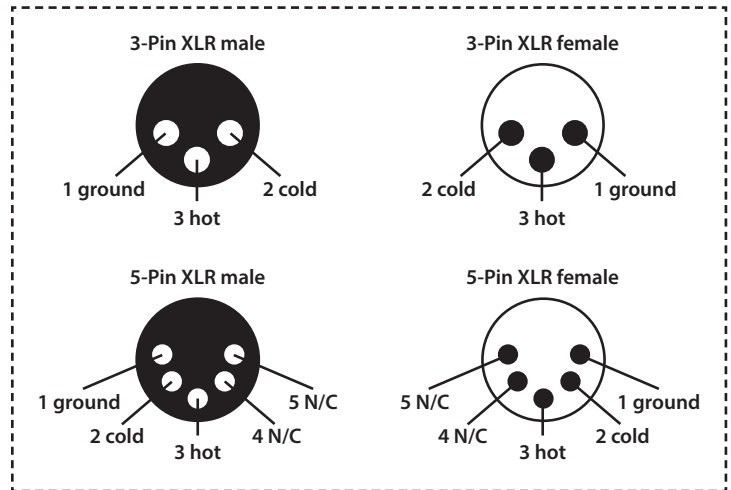
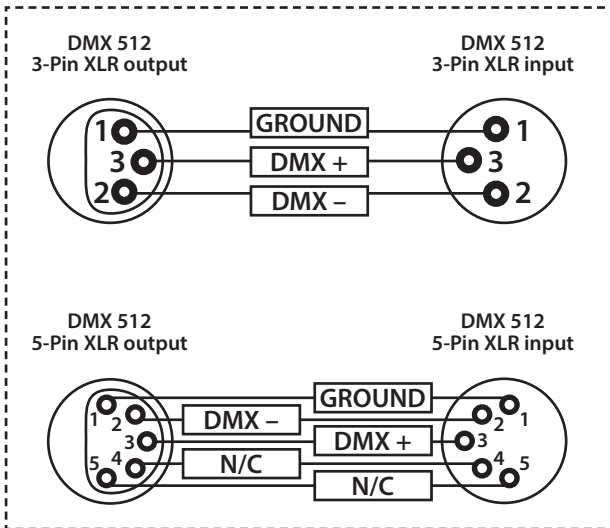

Line termination:

When longer runs of cable are used, you may need to use a terminator on the last unit to avoid erratic behaviour.

Using a cable terminator will decrease the possibilities of erratic behaviour.

(3-pin - Order ref: CABL90,
5-pin - Order ref: CABL89)

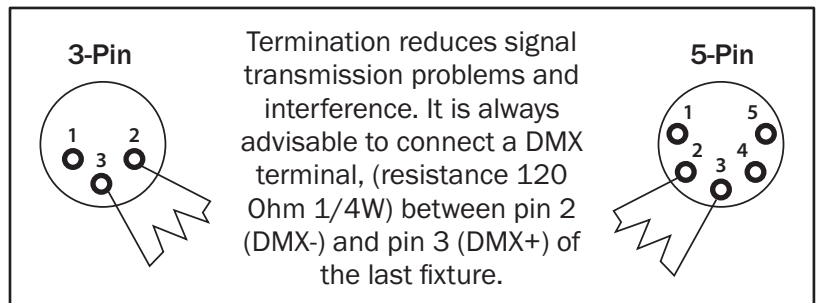

5-pin XLR DMX connectors:

Some manufactures use 5-pin XLR connectors for data transmission in place of 3-pin. 5-pin XLR fixtures may be implemented in a 3-pin XLR DMX line. When inserting standard 5-pin XLR connectors in to a 3-pin line a cable adaptor must be used. The diagram below details the correct cable conversion.

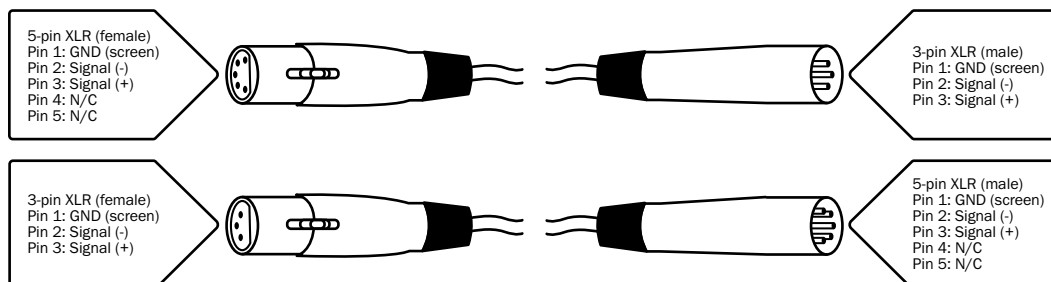

Power linking:

This fixture provides power linking via the power output on the rear allowing multiple units to be connected together. The maximum number of fixtures that can be connected is 14 fixtures @ 240V or 7 fixtures @ 120V (including the first fixture). After the maximum number of fixtures are connected a new power run will need to be started.

Please note: Caution should be used when power linking other fixtures to the Artisan 1000 RGBA Fresnel as the power consumption of other fixtures will vary. Fixtures fitted with lamps often require 2/3 times more current on startup, these may require their own power source.

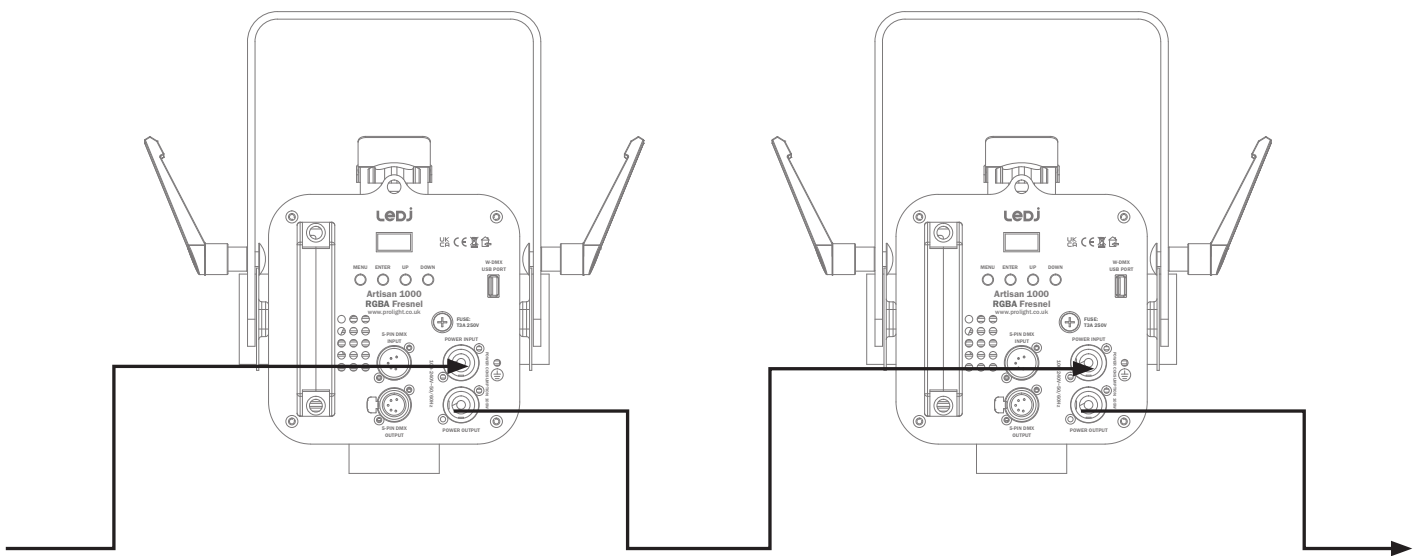



***Correct Disposal of this Product
(Waste Electrical & Electronic Equipment)***

**(Applicable in the European Union and other European countries
with separate collection systems)**

This marking shown on the product or its literature, indicates that it should not be disposed with other household wastes at the end of its working life. To prevent possible harm to the environment or human health from uncontrolled waste disposal, please separate this from other types of wastes and recycle it responsibly to promote the sustainable reuse of material resources.

Household users should contact either the retailer where they purchased this product, or their local government office, for details of where and how they can take this item for environmentally safe recycling.

Business users should contact their supplier and check the terms and conditions of the purchase contract. This product should not be mixed with other commercial wastes for disposal.



LEDj