

# LEDJ

## **Artisan 1000**

## **WW Fresnel**

### User Manual



**Order code: LEDJ335**

### WARNING

## FOR YOUR OWN SAFETY, PLEASE READ THIS USER MANUAL CAREFULLY BEFORE YOUR INITIAL START-UP!

- Before your initial start-up, please make sure that there is no damage caused during transportation.
- Should there be any damage, consult your dealer and do not use the equipment.
- To maintain the equipment in good working condition and to ensure safe operation, it is necessary for the user to follow the safety instructions and warning notes written in this manual.
- Please note that damages caused by user modifications to this equipment are not subject to warranty.



### IMPORTANT:

The manufacturer will not accept liability for any resulting damages caused by the non-observance of this manual or any unauthorised modification to the equipment.

- Never let the power cable come into contact with other cables. Handle the power cable and all mains voltage connections with particular caution!
- Never remove warning or informative labels from the unit.
- Do not open the equipment and do not modify the unit.
- Do not connect this equipment to a dimmer pack.
- Do not switch the equipment on and off in short intervals, as this will reduce the system's life.
- Only use the equipment indoors.
- Do not expose to flammable sources, liquids or gases.
- Always disconnect the power from the mains when equipment is not in use or before cleaning! Only handle the power-cable by the plug. Never pull out the plug by pulling the power-cable.
- Make sure that the available mains supply voltage is between 100~240V AC, 50/60Hz.
- Make sure that the power cable is never crimped or damaged. Check the equipment and the power cable periodically.
- If the equipment is dropped or damaged, disconnect the mains power supply immediately and have a qualified engineer inspect the equipment before operating again.
- If the equipment has been exposed to drastic temperature fluctuation (e.g. after transportation), do not connect power or switch it on immediately. The arising condensation might damage the equipment. Leave the equipment switched off until it has reached room temperature.
- If your product fails to function correctly, stop use immediately. Pack the unit securely (preferably in the original packing material), and return it to your Pro Light dealer for service.
- Only use fuses of same type and rating.
- Repairs, servicing and power connection must only be carried out by a qualified technician. THIS UNIT CONTAINS NO USER SERVICEABLE PARTS.
- This lighting fixture is for professional use only - it is not designed for or suitable for household use. The product must be installed by a qualified technician in accordance with local territory regulations. The safety of the installation is the responsibility of the installer. The fixture presents risks of severe injury or death due to fire hazards, electric shock and falls.
- Warning! Risk Group 2 LED product according to EN 62471. Do not view the light output with optical instruments or any device that may concentrate the beam.
- WARRANTY: One year from date of purchase.

### OPERATING DETERMINATIONS

If this equipment is operated in any other way, than those described in this manual, the product may suffer damage and the warranty becomes void. Incorrect operation may lead to danger e.g: short-circuit, burns and electric shocks etc.

Do not endanger your own safety and the safety of others!

Incorrect installation or use can cause serious damage to people and/or property.

**Please note:** These fixtures are intended for stage lighting and entertainment applications only, and are not intended for extended periods of use, including but not limited to house-light, industrial or architectural applications and should only be operated with short duty cycles.

### Artisan 1000 WW Fresnel

The Artisan 1000 WW Fresnel with a 100W warm white COB LED is ideal for schools, churches and stages and making it an ideal replacement for tungsten fixtures. The beam angle is manually adjustable, with all other features being controllable via the 4 button menu and OLED display or by DMX. The USB socket on the back panel allows for an optional W-DMX compatible transceiver, further expanding the fixtures versatility with wireless master/slave or DMX control.

- 1 x 100W warm white (3200K) COB LED (WW)
- Manually adjustable beam angle: 15° - 45°
- 15° - 7,011 Lux @ 2m (full on), 45° - 1,768 Lux @ 2m (full on)
- Refresh rate: 1.2kHz, 2.4kHz, 4kHz, 6kHz or 10kHz selectable
- DMX channels: 1/2 or 4 selectable
- Artisan Series W-DMX USB compatibility for wireless master/slave or DMX control
- Artisan Series W-DMX USB can be used to receive wireless DMX and relay the DMX signal via the XLR output
- 0-100% dimming
- 4 dimming curves: Linear, square law, inverse square law and S-curve
- Variable strobe
- 4 push button menu with OLED display
- PowerCON input/output
- 5-Pin XLR input/output
- Temperature controlled fan for whisper quiet operation
- Handle on rear panel
- Filter frame and barn doors included



Specifications	Artisan 1000 WW Fresnel
Power consumption	105W
Power supply	100~240V, 50/60Hz
Fuse	T3A 250V
Noise Level	55dBA @ 2m
Dimensions	300 x 300 x 304mm
Weight	4.1kg
Order code	LEDJ335

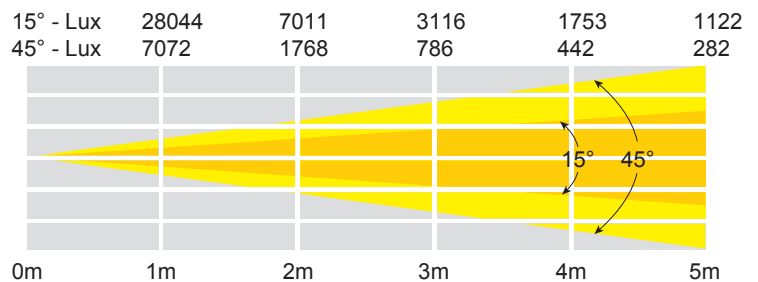

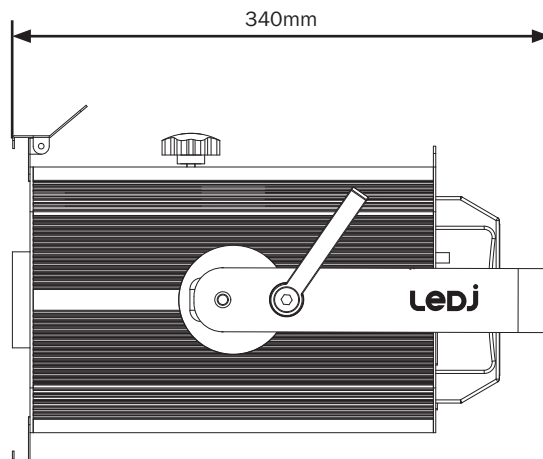
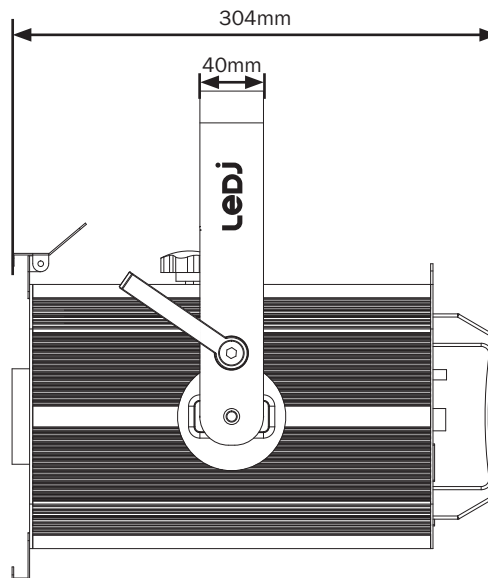
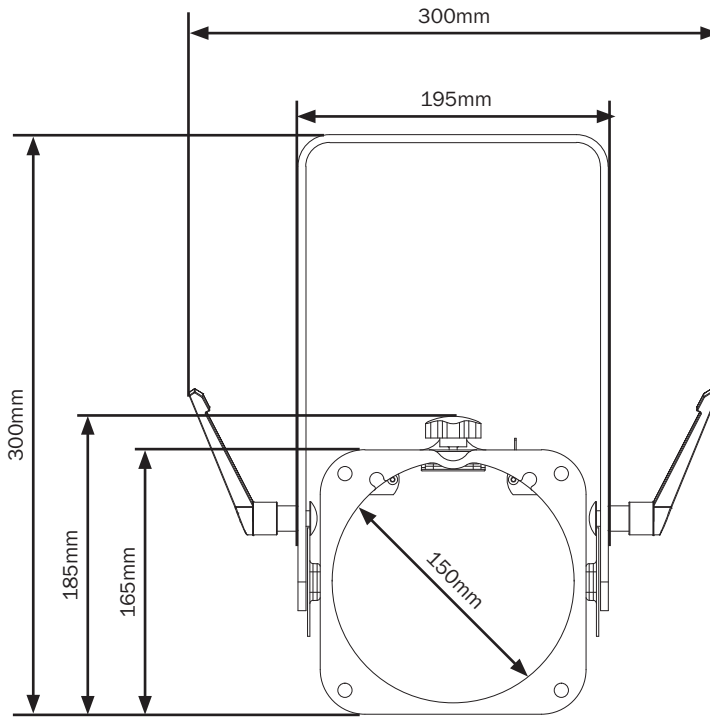

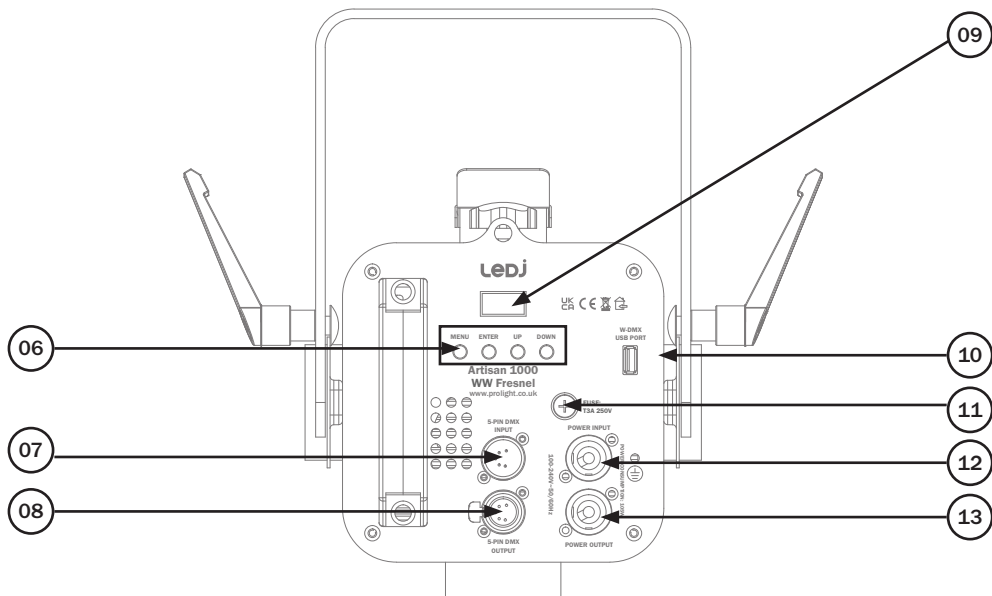
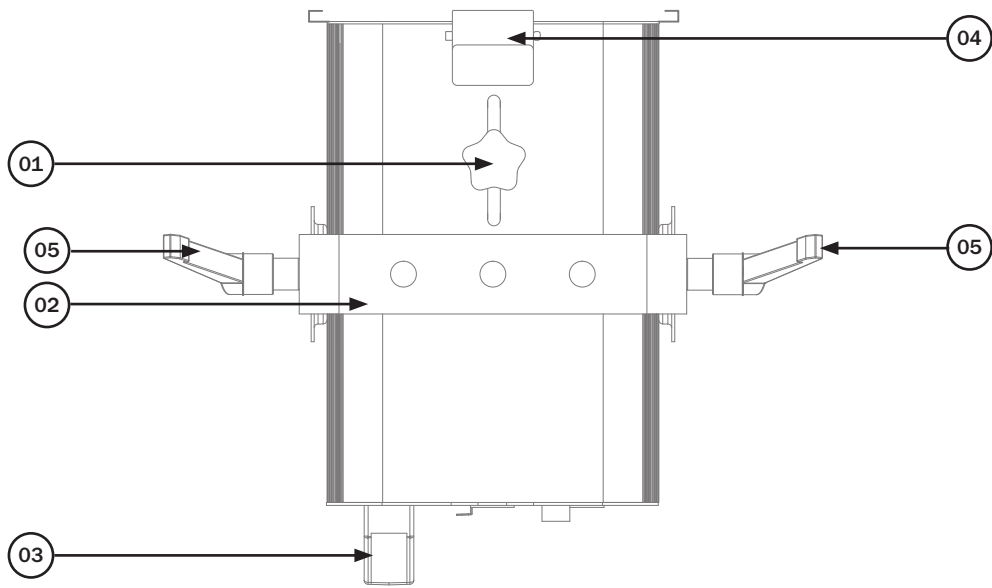

01 - Zoom adjustment

02 - Hanging bracket

03 - Carry handle

04 - Filter frame release mechanism

05 - Hanging bracket adjustable knobs

06 - Function buttons

07 - 5-Pin DMX input

08 - 5-Pin DMX output

09 - LED display

10 - Wireless DMX USB input

11 - Fuse: T3A 250V

12 - PowerCON input

13 - PowerCON output

In the box: **1 x fixture,**  
**1 x barn doors,**  
**1 x filter frame &**  
**1 x power cable**

Main Menu	Sub Menu	Options/Values (Default Settings in BOLD)	Secondary Options/Values (Default Settings in BOLD)
DMX Settings	DMX Address	<b>001</b> -509	
	DMX Channel Mode	1CH	
		<b>2CH</b>	
		4CH	
	No DMX Status	<b>Hold Last</b>	
		Blackout	
Manual Settings			
Personality	Primary	ON/ <b>OFF</b>	
	Secondary	ON/ <b>OFF</b>	
	LED Refresh	1200hz, 2400hz, 4000hz, 6000hz, 10000hz	
	Dim Modes	<b>LED</b>	
		HALOGEN	
	Dim Curve	<b>Linear</b>	
		Square	
		Inv.Squa	
		S.Curve	
	Wireless	ON/ <b>OFF</b>	
Display	Saver Delay		OFF, 1- <b>10</b> seconds
	Menu Lock		OFF - <b>30 seconds</b> , 2-10 minutes
	Rotate Display 180°		YES/ <b>NO</b>
Factory Restore	YES/ <b>NO</b>		
Manual	White	000-255	
	Strobe	000-255	
	Master Dimmer	000-255	
Information	LED Temperature	xxx F/ xxx C	
	Software Version	x.xx	
	Fixture Hours	xxxxxH	

### 1 channel mode:

Channel	Value	Function
1	000-255	Master Dimmer (0-100%)

### 2 channel mode:

Channel	Value	Function
1	000-255	Master Dimmer (0-100%)
2	000-015	No Function
	016-255	Strobe effect (slow to fast)

### 4 channel mode:

Channel	Value	Function
1	000-255	Master Dimmer (0-100%)
2	000-015	No Function
	016-255	Strobe effect (slow to fast)
3	000-020	Default to Unit settings
	021-040	Linear LED
	041-060	Square LED
	061-080	Inv. Squa LED
	081-100	S. Curve LED
	101-120	Linear Halogen
	121-140	Square Halogen
	141-160	Inv. Squa Halogen
	161-180	S. Curve Halogen
	181-255	Default to Unit Settings
4	Refresh Rates	
	000-020	Default to Unit Settings
	021-040	1200hz
	041-060	2400hz
	061-080	4000hz
	081-100	6000hz
	101-120	10000hz
	121-255	Default to Unit Settings

**Wireless operation:**

To operate the fixture wirelessly you will need to plug in the Artisan Series W-DMX Compatible Transceiver (sold separately) into the USB port on the rear of the fixture. W-DMX should also be set to **“ON”** in the fixtures settings (this can be found on page 6).

If using it in wireless DMX mode a compatible wireless DMX Transmitter (e.g. Wireless Solutions Sweden W-DMX Micro F-1 Lite G5 Transceiver) will need to be connected.

The Artisan Series W-DMX Compatible Transceiver features 2 operating protocols as listed below. The LED on the side of the dongle will illuminate a different colour for each operating protocol.

W-DMX G3 Transmit Protocol - Blue (when transmitting)

W-DMX Receive Protocol - Green (when receiving)

To set the dongle in one of these modes plug the Artisan Series W-DMX Compatible Transceiver into the USB port on the rear of the fixture. Press the button on the dongle whilst powering on the unit.

The LED will illuminate white for a brief moment and then change colour. You can then press the button which

will scroll through the operating protocols. Once you have selected the chosen protocol, press and hold the button on the dongle for 3 seconds. The LED will illuminate white, then turn blue (transmit mode) or stay white (receive mode). The unit is now set in your chosen protocol.

**W-DMX G3 Transmit Protocol:**

Once in this protocol the LED will illuminate blue. This indicates the fixture is ready to pair with the receiver(s). Once all the receiver(s) have been set up press the button on the dongle once and the LED will flash blue quickly, this indicates it is attempting to pair with the receivers. Once pairing is complete the LED will illuminate static blue to indicate the fixture is transmitting signal.

To disconnect the transmitting fixture from all receiving fixtures within range when connected, hold the button on the transmitting fixtures dongle down for 3 seconds until the LED illuminates red.

This indicates the wireless memory has been cleared.

**W-DMX Receive Protocol:**

Once in this protocol the LED will illuminate white. This indicates a connection has not yet been established with the transmitter. Once the transmitter has been set up press the button on the transmitter fixtures dongle once or press the pair button on your wireless transceiver. The LED on the receiving units will flash green quickly, this indicates it is attempting to pair with the transmitter. Once pairing is complete the LED will illuminate static green to indicate the fixture is receiving signal.

To disconnect the transmitting fixture from all receiving fixtures within range when connected, hold the button on the transmitting fixtures dongle down for 3 seconds until the LED illuminates white.

This indicates the wireless memory has been cleared.

If the indicator on the receiving units flashes red quickly this indicates that the signal from the transmitting fixture has been lost.



### Setting the DMX address:

The DMX mode enables the use of a universal DMX controller. Each fixture requires a “start address” from 1- 512. A fixture requiring one or more channels for control begins to read the data on the channel indicated by the start address. For example, a fixture that occupies or uses 7 channels of DMX and was addressed to start on DMX channel 100, would read data from channels: 100, 101, 102, 103, 104, 105 and 106. Choose a start address so that the channels used do not overlap. E.g. the next unit in the chain starts at 107.

### DMX 512:

DMX (Digital Multiplex) is a universal protocol used as a form of communication between intelligent fixtures and controllers. A DMX controller sends DMX data instructions from the controller to the fixture. DMX data is sent as serial data that travels from fixture to fixture via the DATA “IN” and DATA “OUT” XLR terminals located on all DMX fixtures (most controllers only have a data “out” terminal).

### DMX linking:

DMX is a language allowing all makes and models of different manufactures to be linked together and operate from a single controller, as long as all fixtures and the controller are DMX compliant. To ensure proper DMX data transmission, when using several DMX fixtures try to use the shortest cable path possible. The order in which fixtures are connected in a DMX line does not influence the DMX addressing. For example; a fixture assigned to a DMX address of 1 may be placed anywhere in a DMX line, at the beginning, at the end, or anywhere in the middle. When a fixture is assigned a DMX address of 1, the DMX controller knows to send DATA assigned to address 1 to that unit, no matter where it is located in the DMX chain.

### DATA cable (DMX cable) requirements (for DMX operation):

This fixture can be controlled via DMX-512 protocol. The DMX address is set on the back of the unit. Your unit requires either a standard 3-pin or 5-pin XLR connector for data input/output, see images below.

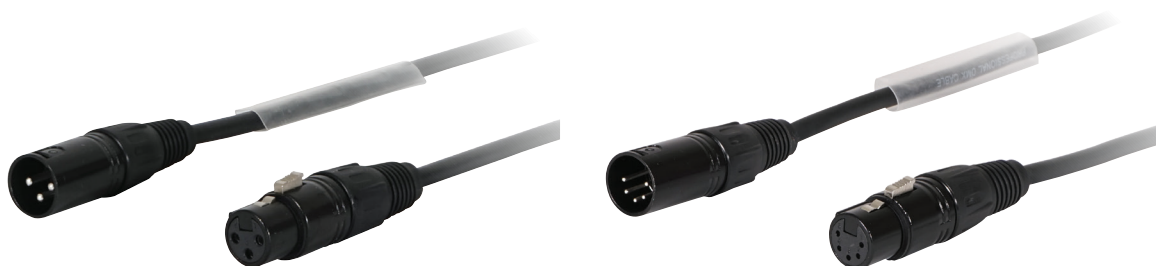

Further DMX cables can be purchased from all good sound and lighting suppliers or Prolight Concepts dealers.

Please quote:	3-Pin:	<b>CABL10 - 2m</b>	<b>CABL11 - 5m</b>	<b>CABL12 - 10m</b>
	5-Pin:	<b>CABL185 - 2m</b>	<b>CABL187 - 5m</b>	<b>CABL188 - 10m</b>

Also remember that DMX cable must be daisy chained and cannot be split.

**Notice:**

Be sure to follow the diagrams below when making your own cables. Do not connect the cables shield conductor to the ground lug or allow the shield conductor to come in contact with the XLRs outer casing. Grounding the shield could cause a short circuit and erratic behaviour.

Pin Configuration	
3-Pin	5-Pin
	Pin 1 - Ground
	Pin 2 - Negative
	Pin 3 - Positive
-	Pin 4 - N/C
-	Pin 5 - N/C

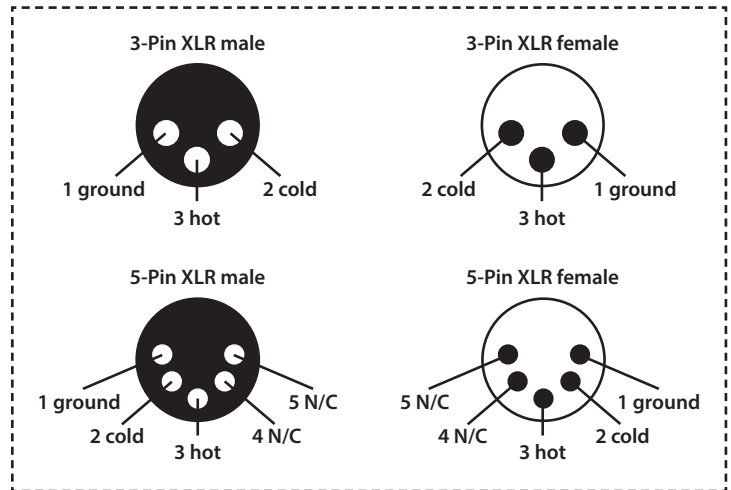
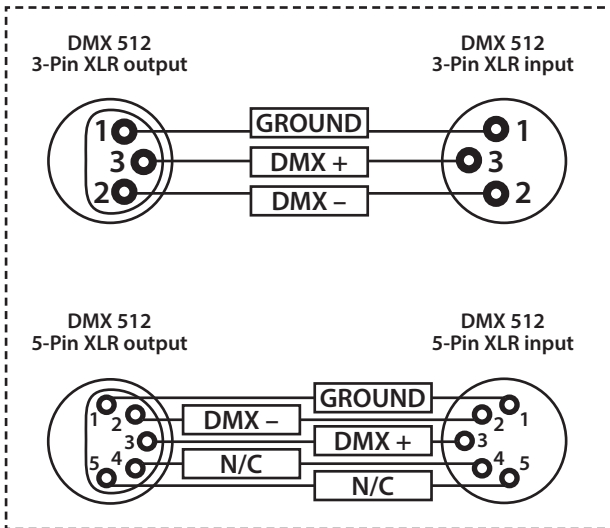

**Line termination:**

When longer runs of cable are used, you may need to use a terminator on the last unit to avoid erratic behaviour.

**Using a cable terminator will decrease the possibilities of erratic behaviour.**

(3-pin - Order ref: CABL90,  
5-pin - Order ref: CABL89)

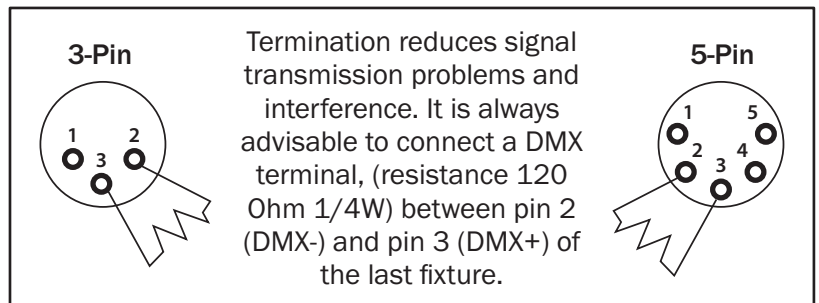

**5-pin XLR DMX connectors:**

Some manufactures use 5-pin XLR connectors for data transmission in place of 3-pin. 5-pin XLR fixtures may be implemented in a 3-pin XLR DMX line. When inserting standard 5-pin XLR connectors in to a 3-pin line a cable adaptor must be used. The diagram below details the correct cable conversion.

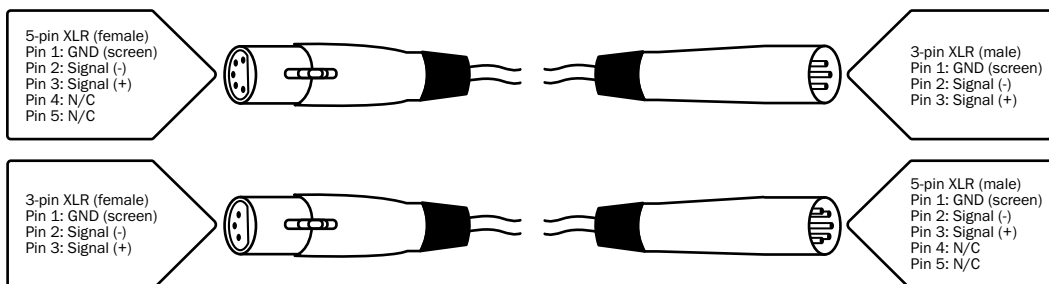

### Power linking:

This fixture provides power linking via the power output on the rear allowing multiple units to be connected together. The maximum number of fixtures that can be connected is 14 fixtures @ 240V or 7 fixtures @ 120V (including the first fixture). After the maximum number of fixtures are connected a new power run will need to be started.

Please note: Caution should be used when power linking other fixtures to the Artisan 1000 WW Fresnel as the power consumption of other fixtures will vary. Fixtures fitted with lamps often require 2/3 times more current on startup, these may require their own power source.

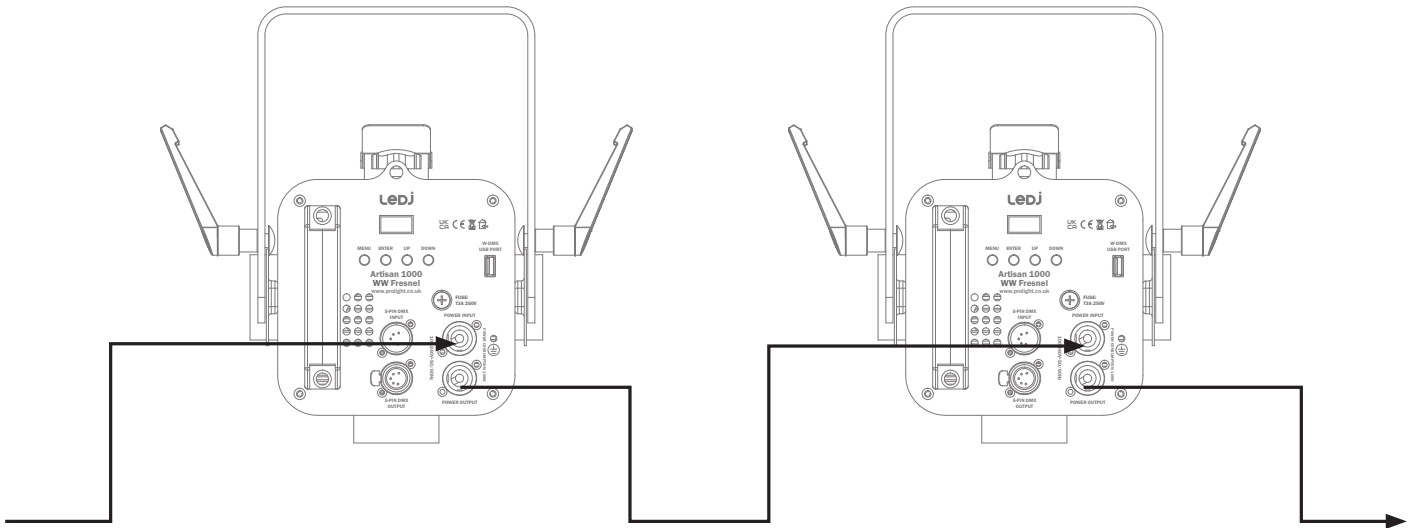



***Correct Disposal of this Product  
(Waste Electrical & Electronic Equipment)***

**(Applicable in the European Union and other European countries  
with separate collection systems)**

This marking shown on the product or its literature, indicates that it should not be disposed with other household wastes at the end of its working life. To prevent possible harm to the environment or human health from uncontrolled waste disposal, please separate this from other types of wastes and recycle it responsibly to promote the sustainable reuse of material resources.

Household users should contact either the retailer where they purchased this product, or their local government office, for details of where and how they can take this item for environmentally safe recycling.

Business users should contact their supplier and check the terms and conditions of the purchase contract. This product should not be mixed with other commercial wastes for disposal.

