

EQUINOX

VS 1500 Fogger

User Manual



Order code: EQLED363

WARNING - FOR YOUR OWN SAFETY, PLEASE READ THIS USER MANUAL CAREFULLY BEFORE YOUR INITIAL START-UP!

- Before your initial start-up, please make sure that there is no damage caused during transportation.
- Should there be any damage, consult your dealer and do not use the equipment.
- To maintain the equipment in good working condition and to ensure safe operation, it is necessary for the user to follow the safety instructions and warning notes written in this manual.
- Please note that damages caused by user modifications to this equipment are not subject to warranty.



IMPORTANT:

The manufacturer will not accept liability for any resulting damages caused by the non-observance of this manual or any unauthorised modification to the equipment.

- Never let the power cable come into contact with other cables. Handle the power cable and all mains voltage connections with particular caution!
- Never remove warning or informative labels from the unit.
- Do not open the equipment and do not modify the unit.
- Do not switch the equipment on and off in short intervals, as this will reduce the system's life.
- Only use the equipment indoors.
- Do not expose to flammable sources, liquids or gases.
- Always disconnect the power from the mains when equipment is not in use or before cleaning! Only handle the power-cable by the plug. Never pull out the plug by pulling the power-cable.
- Make sure that the available mains supply voltage is between 220~240V, 50/60Hz.
- Make sure that the power cable is never crimped or damaged. Check the equipment and the power cable periodically.
- If the equipment is dropped or damaged, disconnect the mains power supply immediately and have a qualified engineer inspect the equipment before operating again.
- If the equipment has been exposed to drastic temperature fluctuation (e.g. after transportation), do not connect power or switch it on immediately. The arising condensation might damage the equipment. Leave the equipment switched off until it has reached room temperature.
- If your product fails to function correctly, stop use immediately. Pack the unit securely (preferably in the original packing material), and return it to your Prolight dealer for service.
- Only use fuses of same type and rating.
- Repairs, servicing and power connection must only be carried out by a qualified technician. THIS UNIT CONTAINS NO USER SERVICEABLE PARTS.
- This fixture is for professional use only - it is not designed for or suitable for household use. The product must be installed by a qualified technician in accordance with local territory regulations. The safety of the installation is the responsibility of the installer. The fixture presents risks of severe injury or death due to fire hazards, electric shock and falls.
- WARRANTY: One year from date of purchase.

OPERATING DETERMINATIONS

If this equipment is operated in any other way, than those described in this manual, the product may suffer damage and the warranty becomes void. Incorrect operation may lead to danger e.g: short-circuit, burns and electric shocks etc.

Do not endanger your own safety and the safety of others!

Incorrect installation or use can cause serious damage to people and/or property.

Before filling the unit disconnect the mains. Never fill with hot liquids.

Only use high quality, water based smoke fluid recommended by the manufacturer.

Other smoke fluids may cause clogging and void the guarantee.

Always make sure there is sufficient smoke fluid in the tank. Operating this smoke machine without smoke fluid will cause damage to the pump as well as over heating of the heater.

Operate the unit only after you have familiarised yourself with its functions. Do not permit operation by persons not qualified for operating the unit and always drain the tank and use the original packaging if the unit is to be transported.

VS 1500 Fogger

The high performance VS 1500 fogger has been designed to output high volumes of fog via the supplied wired or wireless remotes, or via DMX. Its robust design makes it ideal for use in a variety of environments including nightclubs, stage shows and theatres.

- 1 x 1500W heater
- Smoke output: approx. 15,000 cu.ft per minute
- Warm-up time: approx. 4 minutes
- Tank capacity: 2.3 litres
- DMX channels: 1
- Hand-held remote control included (3.5m cable length)
- Wireless control included
- IEC power input
- 3-Pin XLR input/output
- Supplied with hanging bracket
- Use with water based fog fluid (Order code: FLUI21)



Specifications	
Power consumption	1500W (max.)
Power supply	220~240V, 50/60Hz
Fuse	F8A 250V
Dimensions (H x W x D)	290 x 272 x 390mm
Weight	6.5kg
Order code	EQLED363

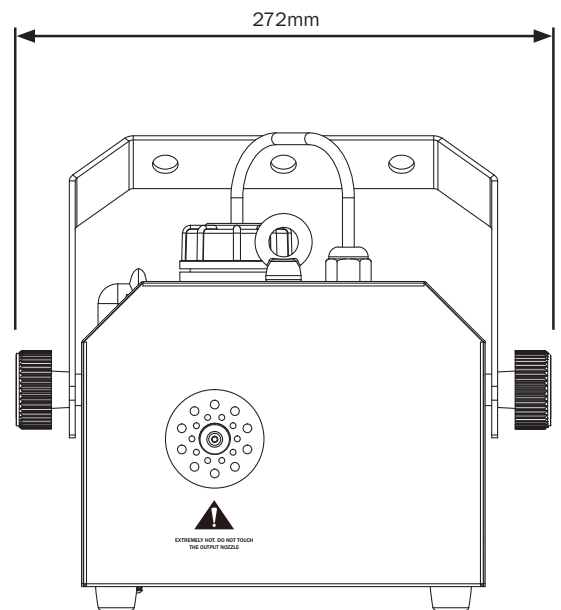
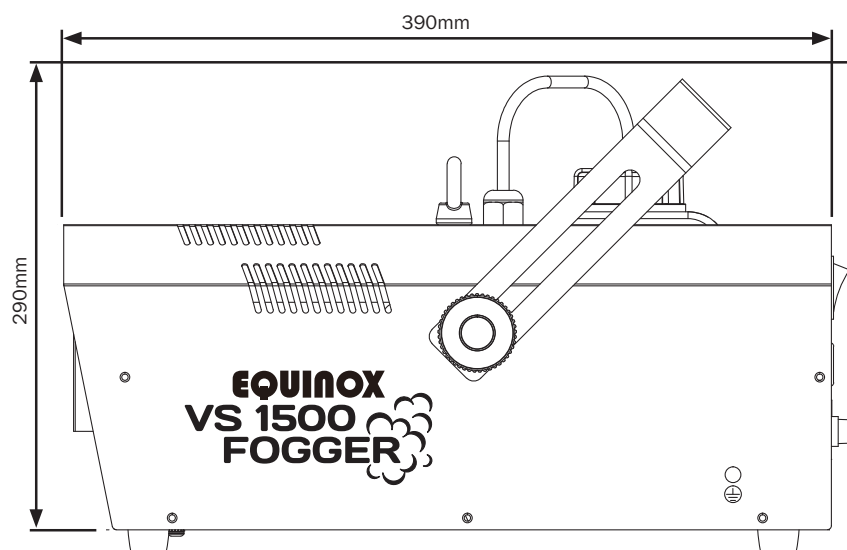

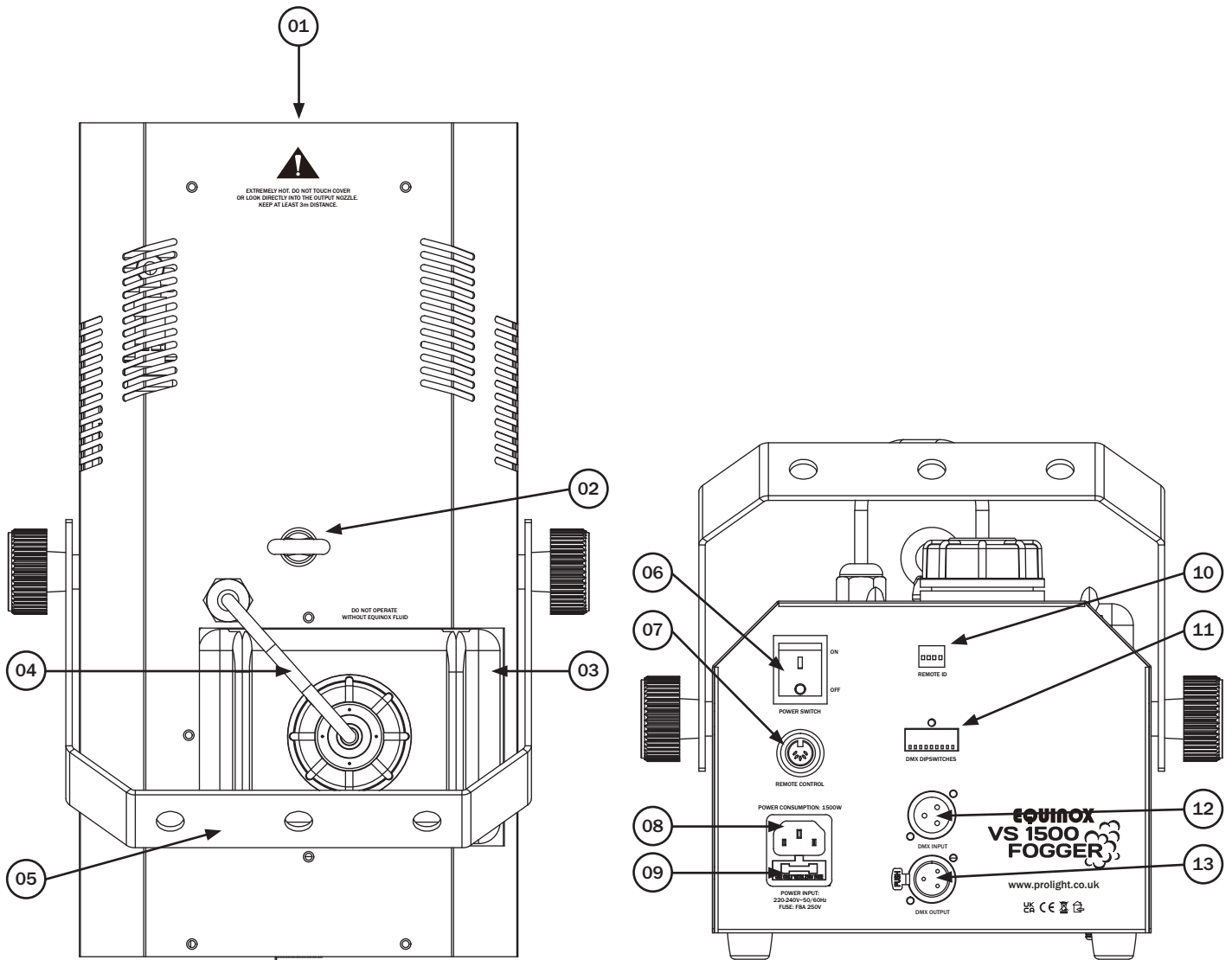

- 01 - Output nozzle
- 02 - Safety eye
- 03 - Fluid tank*
- 04 - Fluid pipe
- 05 - Carry handle
- 06 - Power on/off switch
- 07 - Remote input
- 08 - Power input
- 09 - Fuse
- 10 - Wireless remote dipswitches
- 11 - DMX dipswitches**
- 12 - 3-Pin DMX input
- 13 - 3-Pin DMX output

* Fluid tank:

- Illuminates 'Red' during heating process
- Illuminates 'Red & Blue' to indicate the unit is 'Ready to fog' but still heating
- Illuminates 'Blue' to indicate the unit is 'Ready to fog'

** DMX dipswitches:

- The LED above the dipswitches illuminates when a DMX signal is detected

In the box:
1 x fogger, 1 x wired remote, 1 x wireless remote
1 x IEC cable

Operation:

Place the unit on a level surface.

Always disconnect it from the mains supply before filling as fluid could be spilled.

Fluid replenishment:

Always fill the tank away from the unit to prevent fluid getting inside the main housing.

If fluid should get inside the main housing, disconnect the unit from the mains immediately and consult a technician.

Power the unit down using the on/off switch on the rear panel and unplug the power cable. Turn the fluid bottle lid counter-clockwise to unscrew and remove the fluid tank from the main housing.

Fill the tank with fluid and place the tank back in the housing. Place the lid on the fluid bottle and turn clockwise to tighten. Plug the power cable back into the unit and power it on using the on/off switch on the rear panel.

Installation:

Install the unit in a well-ventilated area. Use in an insufficiently ventilated room can lead to the condensation of the smoke fluid. The resulting slippery surface can cause accidents. Keep a minimum distance of 1m around the unit.

Furthermore do not orientate the output aperture directly in the direction of the audience's eyes. In order to create the best effect, there should be a distance between the unit and the audience of at least 3m.

Only install the unit on fire resistant, scratch resistant and water resistant surfaces.



DANGER OF FIRE!

When installing the unit, make sure there is no highly flammable material (decoration articles etc) within a minimum distance of 1m

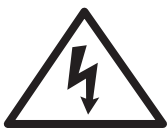

DANGER TO LIFE!

Disconnect from the mains before starting maintenance

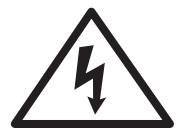

Only use quality fog fluids recommended by your dealer. You must not use substances which are classified as 'DANGEROUS WORKING MATERIALS' or 'FLAMMABLE FLUIDS'.

Operation:

Wireless remote:

1. LED indicator illuminates when you press any button (if doesn't illuminate or the LED is dim - replace battery)
2. Fog buttons 1 to 4*

*Press the fog button, and the fog machine will output fog for as long as you hold down the button.

Being a 4 channel wireless remote control, several of these units can be operated at once, either 4 separate units (1 per button) or by setting the receiver dipswitch buttons to the same number and assigning them to just one button on the remote (all machines set to 1 will operate when button 1 on the wireless remote is pressed). **Please note: ON on the dipswitches is down.**

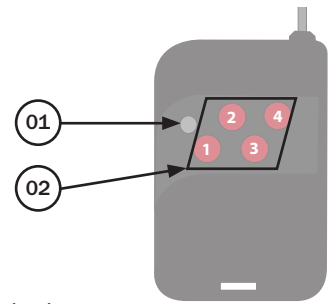

Wired remote:

1. Timer on/off button
2. Continuous output
3. Manual override button
4. Timer LED indicator (Illuminates yellow when timer active)
5. Manual ready indicator (Illuminates green when ready)
6. Power indicator (Illuminates red when power is on)
7. Adjust the output level between 0-100%.

The below controls are only used when in timer mode

8. Adjust the output interval between each release (between 0-30 min approx.)
9. Adjust the duration the fog is released at each interval (between 0-15 sec approx.)

For best results select "continuous" and adjust output to achieve desired effect.

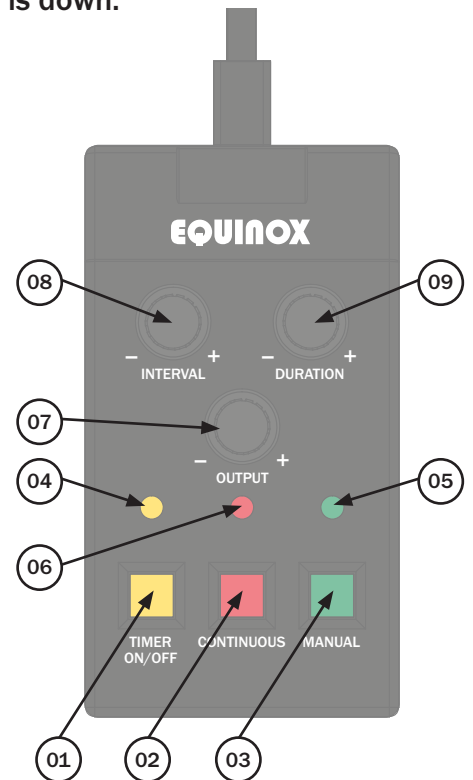

DMX mode:

Channel	Value	Function
CH1	000-005	No function
	006-255	Output volume (5-100%)

To set the DMX address please see the example table below: (Note: 1 = On, 0 = Off)

DMX Address	Dipswitches								
	1	2	4	8	16	32	64	128	256
1	1	0	0	0	0	0	0	0	0
2	0	1	0	0	0	0	0	0	0
3	1	1	0	0	0	0	0	0	0
4	0	0	0	0	0	0	0	0	0
...
511	1	1	1	1	1	1	1	1	1

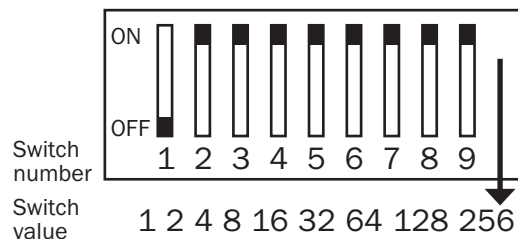

Cleaning and maintenance:

We recommend a frequent cleaning of the unit. Make sure the machine has cooled before cleaning. Please use a soft lint-free and moistened cloth. Remove dust from air vents using an air compressor, vacuum or soft brush. Never use alcohol or solvents! Clean the output nozzle after each use to remove fluid residues and water vapour.

To avoid the inside pipes becoming blocked we recommend running a solution through the unit every 40 hours. The solution should be made up of 35% vinegar and 65% distilled water and should be fogged through the system 10-15 times.

To do this power the fixture down using the on/off switch on the rear panel and unplug the power cable. Turn the fluid bottle lid counter-clockwise to unscrew and remove the fluid tank from the main housing. Empty the tank of any remaining fluid and fill the tank with the vinegar and distilled water solution. Place the tank back in the housing. Place the lid on the fluid bottle and turn clockwise to tighten. Plug the power cable back into the unit and power it on using the on/off switch on the rear panel. Allow the unit to heat up and run the machine in a well ventilated area until the tank is empty of solution. DO NOT allow the pump to run dry. Power the fixture down using the on/off switch on the rear panel and unplug the power cable. Turn the fluid bottle lid counter-clockwise to unscrew and remove the fluid tank from the main housing. Empty the tank of any remaining solution and fill the tank with fluid. Place the tank back in the housing. Place the lid on the fluid bottle and turn clockwise to tighten. Plug the power cable back into the unit and power it on using the on/off switch on the rear panel. Allow the unit to heat up and run the machine briefly to clear any remaining solution from the pump/heater.

The fluids we recommend are non-hazardous to the environment and can be disposed of via the sewage system.

There are no serviceable parts.

Maintenance and service operations are only to be carried out by authorised dealers.

Trouble shooting:

Symptom	Possible solution
No power	Check mains power. Check fuse.
No fog output	Check fluid level. Check remote. If using wireless, check batteries.
Breaker/Fuse keeps blowing	Possible electrical short. Contact reseller for further instructions.
Low fog output	Run a cleaning solution through the fog machine.
Fog machine is not heating up	Check fuse. Possible faulty part. Contact reseller for further instructions.
Remote does not work	Make sure connector is firmly connected to the unit. Try using another controller. Possible faulty controller. Check fuse. If using wireless, check batteries.
Fluid indicator states no fog, but the container is full	Try resetting the fog machine by turning the power off, and then on again. Possible faulty part. Contact reseller for further instructions.

Setting the DMX address:

The DMX mode enables the use of a universal DMX controller. Each fixture requires a “start address” from 1- 512. A fixture requiring one or more channels for control begins to read the data on the channel indicated by the start address. For example, a fixture that occupies or uses 7 channels of DMX and was addressed to start on DMX channel 100, would read data from channels: 100, 101, 102, 103, 104, 105 and 106. Choose a start address so that the channels used do not overlap. E.g. the next unit in the chain starts at 107.

DMX 512:

DMX (Digital Multiplex) is a universal protocol used as a form of communication between intelligent fixtures and controllers. A DMX controller sends DMX data instructions from the controller to the fixture. DMX data is sent as serial data that travels from fixture to fixture via the DATA “IN” and DATA “OUT” XLR terminals located on all DMX fixtures (most controllers only have a data “out” terminal).

DMX linking:

DMX is a language allowing all makes and models of different manufactures to be linked together and operate from a single controller, as long as all fixtures and the controller are DMX compliant. To ensure proper DMX data transmission, when using several DMX fixtures try to use the shortest cable path possible. The order in which fixtures are connected in a DMX line does not influence the DMX addressing. For example; a fixture assigned to a DMX address of 1 may be placed anywhere in a DMX line, at the beginning, at the end, or anywhere in the middle. When a fixture is assigned a DMX address of 1, the DMX controller knows to send DATA assigned to address 1 to that unit, no matter where it is located in the DMX chain.

DATA cable (DMX cable) requirements (for DMX operation):

This fixture can be controlled via DMX-512 protocol. The DMX address is set on the back of the unit. Your unit requires either a standard 3-pin or 5-pin XLR connector for data input/output, see images below.

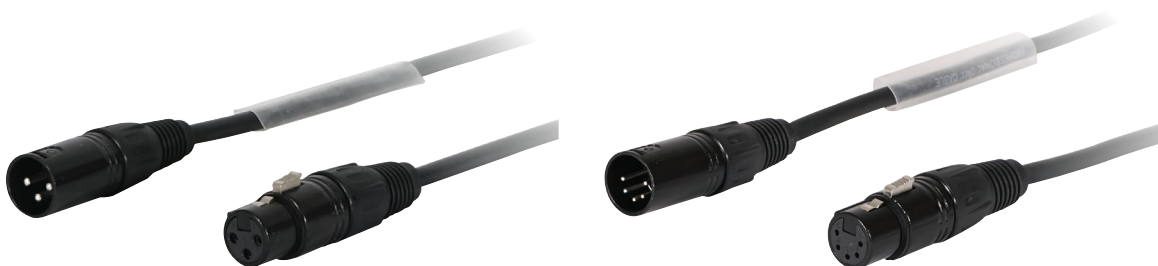

Further DMX cables can be purchased from all good sound and lighting suppliers or Prolight Concepts dealers.

Please quote:	3-Pin:	CABL10 – 2m	CABL11 – 5m	CABL12 – 10m
	5-Pin:	CABL185 – 2m	CABL187 – 5m	CABL188 – 10m

Also remember that DMX cable must be daisy chained and cannot be split.

Notice:

Be sure to follow the diagrams below when making your own cables. Do not connect the cables shield conductor to the ground lug or allow the shield conductor to come in contact with the XLRs outer casing. Grounding the shield could cause a short circuit and erratic behaviour.

Pin Configuration	
3-Pin	5-Pin
	Pin 1 - Ground
	Pin 2 - Negative
	Pin 3 - Positive
-	Pin 4 - N/C
-	Pin 5 - N/C

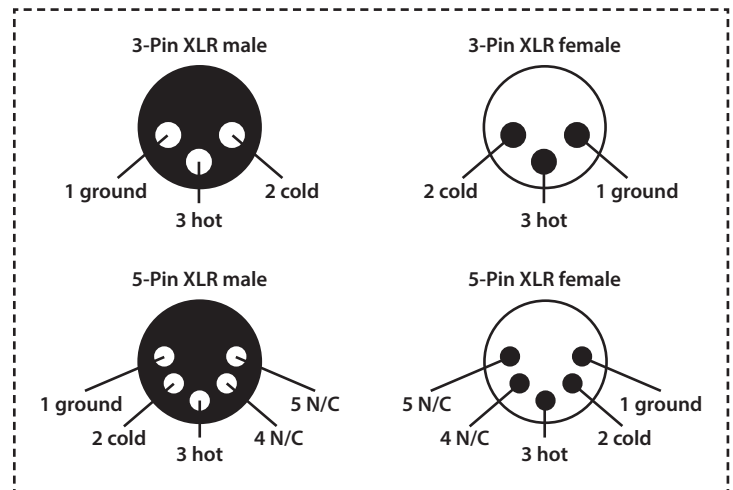
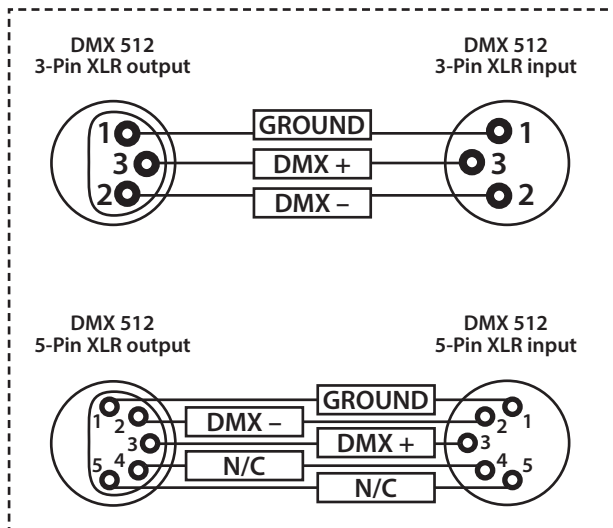

Line termination:

When longer runs of cable are used, you may need to use a terminator on the last unit to avoid erratic behaviour.

Using a cable terminator will decrease the possibilities of erratic behaviour.

(3-pin - Order ref: CABL90,
5-pin - Order ref: CABL89)

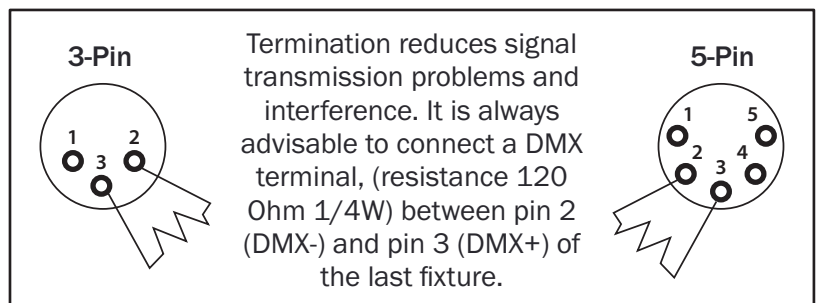

5-pin XLR DMX connectors:

Some manufactures use 5-pin XLR connectors for data transmission in place of 3-pin. 5-pin XLR fixtures may be implemented in a 3-pin XLR DMX line. When inserting standard 5-pin XLR connectors in to a 3-pin line a cable adaptor must be used. The diagram below details the correct cable conversion.

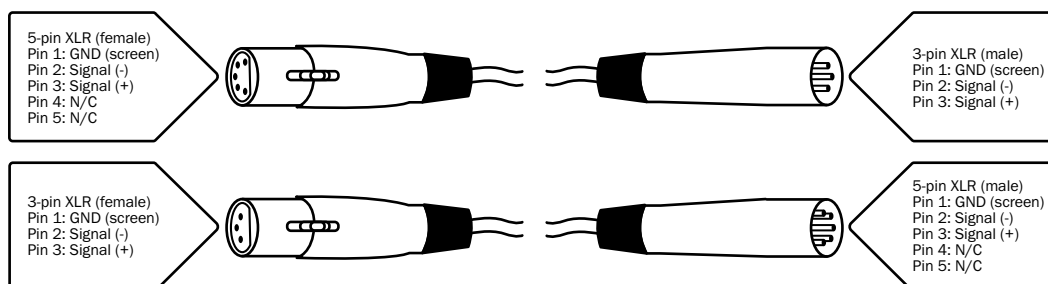



Correct Disposal of this Product (Waste Electrical & Electronic Equipment)

**(Applicable in the European Union and other European countries
with separate collection systems)**

This marking shown on the product or its literature, indicates that it should not be disposed of with other household wastes at the end of its working life. To prevent possible harm to the environment or human health from uncontrolled waste disposal, please separate this from other types of wastes and recycle it responsibly to promote the sustainable reuse of material resources.

Household users should contact either the retailer where they purchased this product, or their local government office, for details of where and how they can take this item for environmentally safe recycling.

Business users should contact their supplier and check the terms and conditions of the purchase contract. This product should not be mixed with other commercial wastes for disposal.



EQUINOX