



PX PORTABLE 3-CHANNEL PERSONAL MIXER

For personal IEM/headphone mixes for live and recording

COMPLETE PX SYSTEM

As a musician and/or singer, whether you're performing live, rehearsing with a band or recording in a studio, you need to hear both yourself and the other musicians. But just as importantly, you need to have control over what you hear. Everyone hears differently from their own perspective, so everyone needs to have control over their own mix.

Ideally, you'd have a monitor engineer—but in most situations it's likely that you or another band member are controlling the monitor mix from the stage. Or a sound technician at the other end of the room has the control; but it's hard to communicate with them during a show. Instead of having a fixed monitor mix from the board, PX allows you to set up a simple three-channel monitor mix that allows you to adjust the levels that matter to you the most—on the fly. For example, one knob could control your vocal level, one could control your instrument level, and another could be a submix of other vocals and instruments.

With the PX system, control of that balance is always within reach, and always adjusted perfectly to your liking!

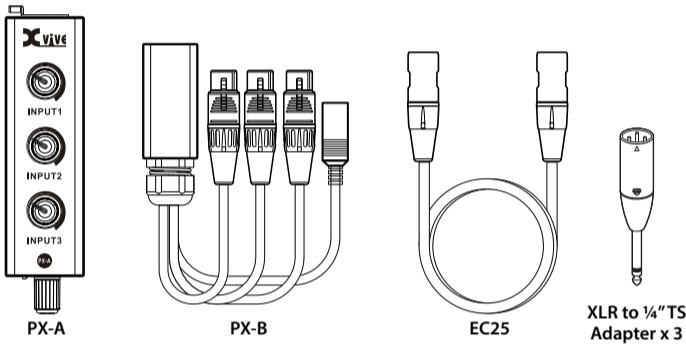

FEATURES

- 3-channel mixer and headphone amplifier for personal in-ear-monitoring applications
- Ultra-compact and lightweight design
- Cat 5 cable transmits three channels of audio and 9 volts of Power over Ethernet (PoE)
- Three balanced female XLR plugs connect to your mixing console or other audio devices
- Level control knob powers off the unit all the way counterclockwise
- Three balanced XLR to unbalanced 1/4" adapters included
- DIP switches inside PX allow you to control how each channel is panned: left, right, or both
- PoE/battery power switch selects either Cat 5 9V PoE power or 2x AAA battery power
- Runs for up to 5 hours on 2 AAA batteries (not included)
- LED indicates when battery power is being used
- Sturdy backpack clip
- Ultra-rugged impact-resistant metal chassis
- Ethernet cable can simultaneously transmit audio and power over a distance of up to 200 ft

SPECIFICATIONS

Input type:	Balanced XLR
Input impedance:	13.3 kΩ
Output type:	1/8" TRS (stereo)
Output impedance:	8-80 Ω
Max. output:	2x 150 mW @ 16 Ω
Power input:	PoE (Power over Ethernet) or 2x AAA batteries
Battery life:	~5 hours
Current:	~210 mA
Ethernet cable length:	25 feet / 7.6 m
PoE power requirement:	9V/2A center-negative (powers up to 5 PX-A units) 9V / 500mA center-negative for one PX-A unit

WARNING

LISTENING TO AUDIO AT EXCESSIVE VOLUMES CAN CAUSE PERMANENT HEARING DAMAGE. USE AS LOW A VOLUME AS POSSIBLE.

Overexposure to excessive sound levels can damage your ears, resulting in permanent noise-induced hearing loss. Do not use earphones for a long time and set the volume below 50%.

TROUBLESHOOTING

NO SOUND

- Check that the audio source is connected to PX-B and sending signal
- Check that the EC25 cable is connected to PX-A and PX-B
- Check that input 1, 2, and 3 volume controls on PX-A are not turned all the way down
- Check that the main volume knob / power switch is turned on
- Check that earphones/headphones are properly connected
- Check that left and right channel switches in the battery case are not all set to the off position

NO POWER

- Check that the PX-A power switch (/volume knob) is turned on
- Check that the power mode switch is correctly set to PoE or AAA battery
- Check that the batteries have been installed correctly
- Check to make sure that the PoE power adapter used is 9V/2A DC center-negative
- Check that the EC25 cable is in working order and connected properly

LIMITED WARRANTY

For the applicable warranty terms and conditions and additional information regarding the Xvive Limited Warranty, please email support@xvive.com.

LEGAL DISCLAIMER

Xvive accepts no liability for any loss which may be suffered by any person who relies either wholly or in part upon any description, photograph, or statement contained herein. Technical specifications, appearances and other information are subject to change without notice.

PRODUCT OVERVIEW

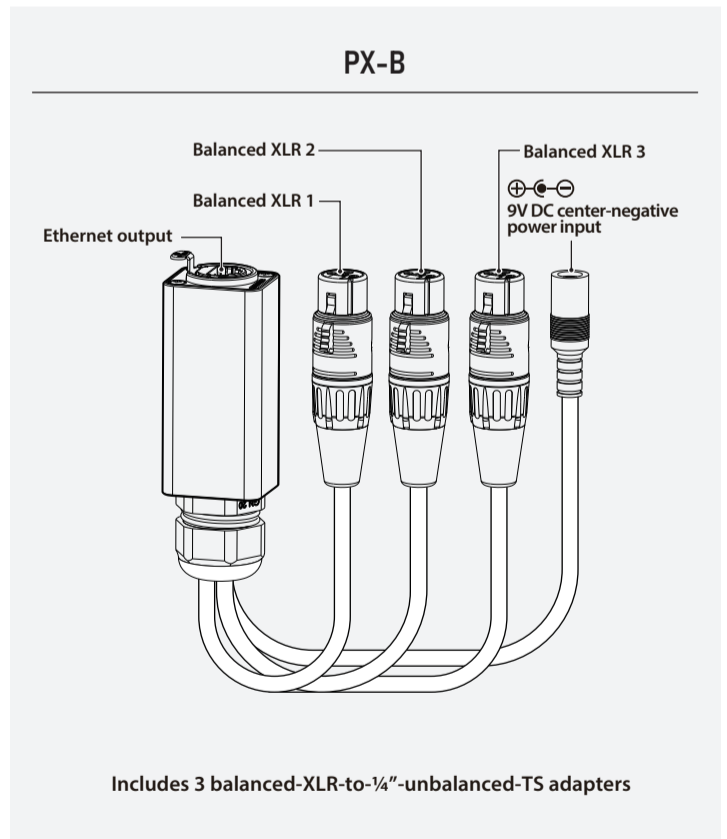
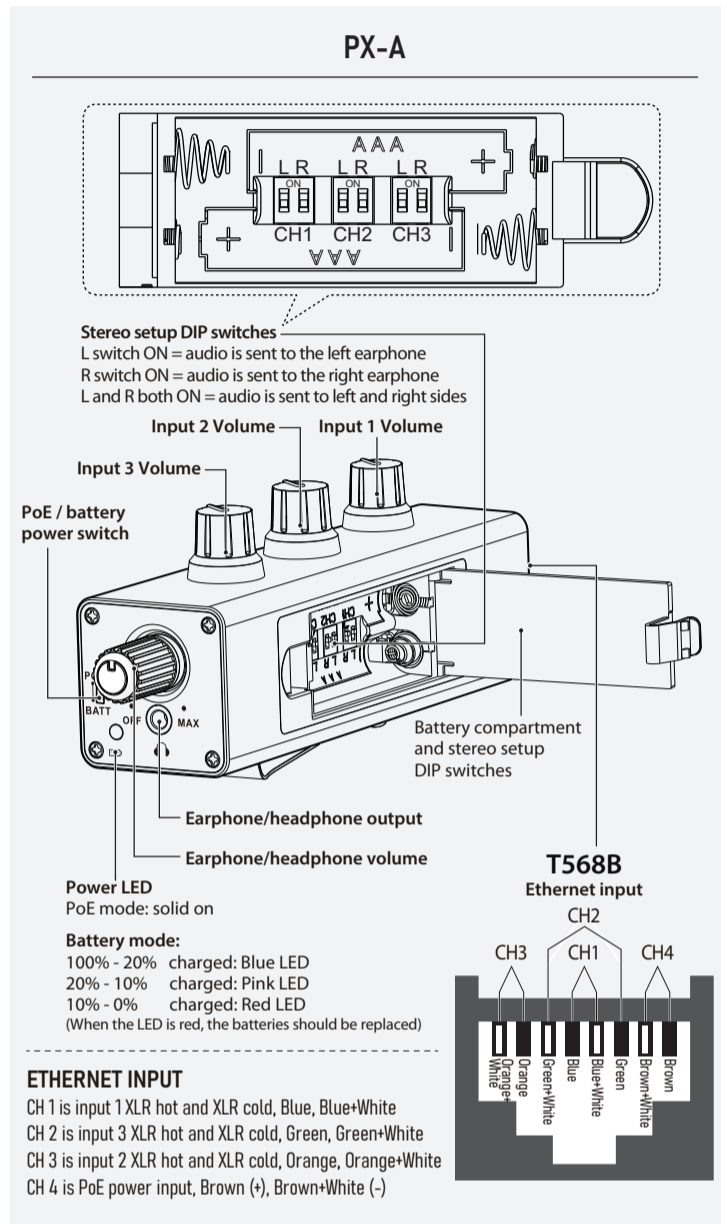

DISTORTED AUDIO

- Check if the master volume is too high
- Check the levels going in and out of the PX-A mixer
- Verify that each signal is not distorted at the audio source
- Low batteries can cause distortion. Check batteries and replace if necessary.

LOW AUDIO LEVEL FROM THE PX-A EARPHONE OUTPUT

- Check the PX-A master volume (earphone/headphone output) level
- Check CH1, CH2, CH3 volume levels
- Check output levels from audio sources (e.g. mixing console aux outs)

MULTIPLE CONNECTIONS WITH PX-H

- The PX-B signal can be sent to up to five PX-A units via the PX-H Hub, to be heard simultaneously by up to five people. You can also stack multiple PX-H units to build a larger system for more than 5 people.

QUICK START GUIDE

1. Connect audio sources

Example:

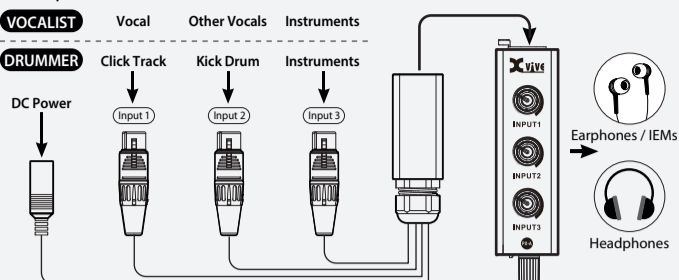

2. Connect ethernet cable

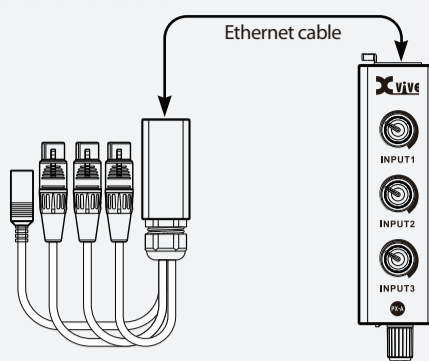

3. Connect to power, using a 9V power supply or two AAA batteries (9V power adapter not included)

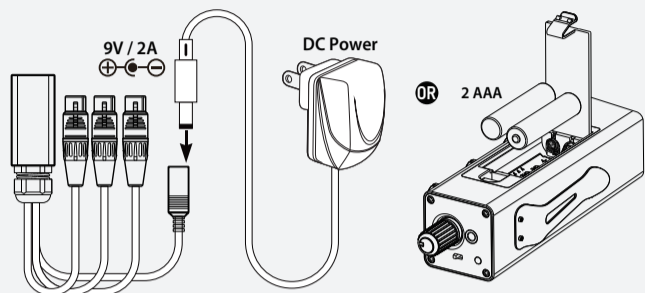

4. Set input 1, input 2 and input 3 volumes to 12 o'clock

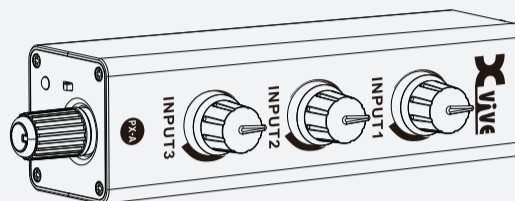

5. Set the panning of your three channels as desired: left, right or center

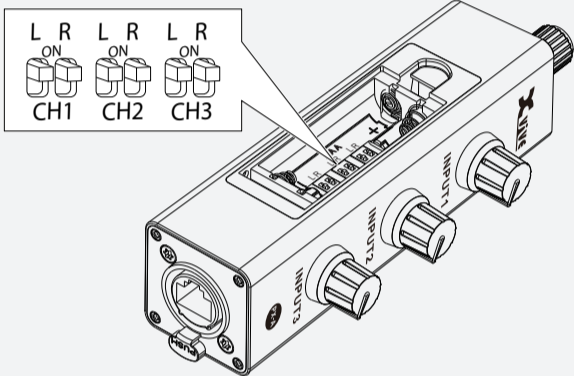

6. Wearing earphones/headphones, turn on the power and slowly adjust the PX-A master volume to the appropriate level. Then, adjust the volume of each channel at the source/s (e.g. aux output levels on the soundboard) to achieve a good starting mix. During performance, adjust channel volumes and master volume on the PX-A as needed.

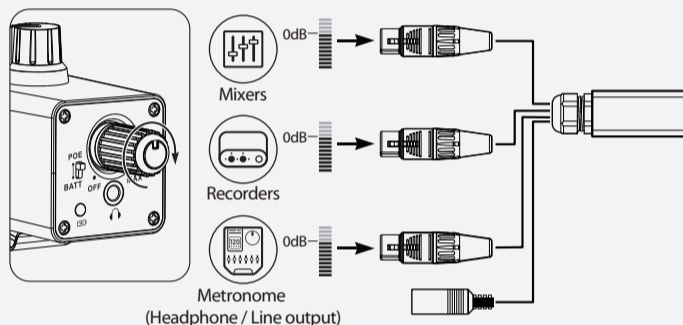

APPLICATION EXAMPLES

1. Basic setup for a singer

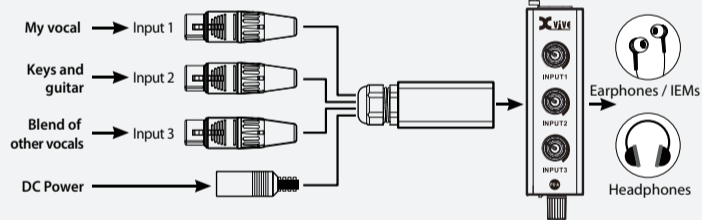

2. Setup for two singers/instrumentalists

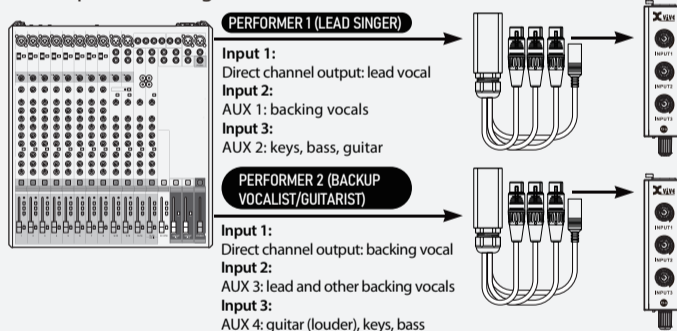

3. Setup for a whole band

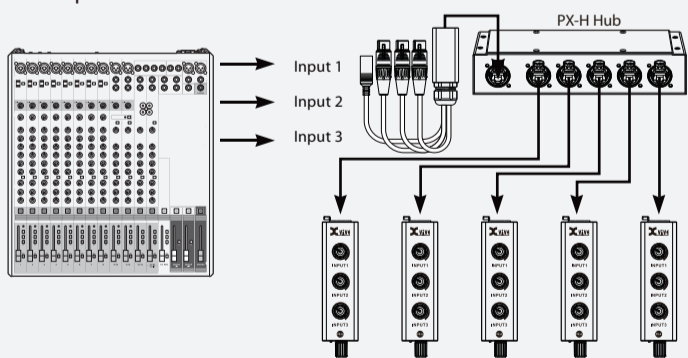

4. Recording in a studio

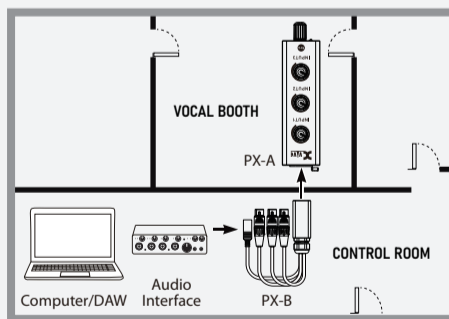

DRUMMER

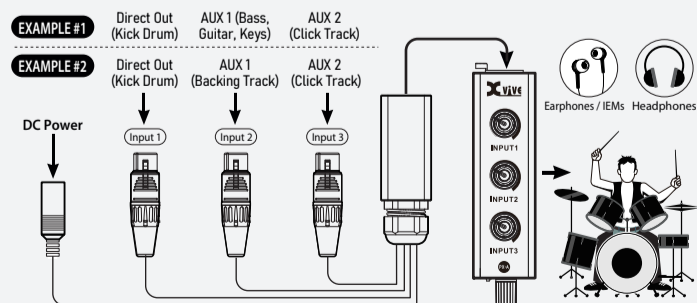

KEYBOARDIST

