

LedPOINT²®



ROBE®

LedPOINT[®]

WHITE LED
TE™ 280W XP
ENGINE

BEAM, SPOT
WASH & FX
FIXTURE

ZOOM
RANGE
1.8° - 44°

CMY
COLOUR MIXING
SYSTEM

ULTRA FAST
CONTINUOUS
PAN

SPKTRABEAM™
EFFECTS
ENGINE

WEIGHT
21 KG

ROTATING & STATIC
GOBOS
ANIMATION
WHEEL



Now is the perfect time to transition from traditional discharge lamp based all-in-one luminaires to energy efficient, long lasting, low maintenance LED fixtures. Our LedPOINTE® is effect packed, with all the features, innovation and superior performance you would expect to see from Robe, delivering a stand-out experience in LED Spot, Beam, Wash and FX technology.



LedPOINTE® is equipped with the advanced TE™ 280W XP (Xtra Performance) White LED TRANSFERABLE ENGINE, delivering an impressive 160.000 lx at 5 m distance. With an L70 rating of 50.000 hours, this high-performance engine offers exceptional durability—meaning you won't need to worry about replacements anytime soon.

Designed for versatility and eye-catching visuals, LedPOINTE® features a 150mm front lens with a 2:1 beam hot-spot ratio and a flexible 1.8° - 44° zoom range, making it ideal for all applications.

You'll enjoy fast, smooth fixture movement with continuous pan rotation, and with our patented EMS™ (Electronic Motion Stabilizer) software, you'll achieve instant stopping precision, eliminating any unwanted shake or hysteresis.

Colour control is seamless with the CMY colour mixing system, allowing easy blending from delicate pastels to deep saturates. A colour wheel contains 13 dichroic colours. The onboard DataSwatch™ library provides instant access to your favourite colours and the most used calibrated whites - 2.700K, 3.200K, 4.200K, 5.600K and 8.000K are included for faster programming, letting you quickly adapt to the needs of any performance.

LedPOINTE® is built to impress, with an extensive effect array, including two gobo wheels. The first with 9 rotating, indexable and rotating gobos. The second static wheel contains another 11 gobos. All are selected for maximum impact and in-air effect capability.

Two MagFrost™ magnetic paddle fast-change frosts with standard light 1° and medium 5° are included. Other MagFrost™ options are available.

Two Prism wheels add to the effect availability. Featuring the Robe patented stackable MLP™ Multi-Level Prism system, there are two wheels. The first has a 6-facet linear and 18-facet radial independently controlled prisms with bi-directional speed control. For a show-stopping experience, the patented SpektraBeam™ effects engine, on the second prism wheel, creates intense splintered beams with vivid colours that will mesmerize audiences. 8-facet radial prism is added on the second wheel for more visual effects.

With L3™ (Low Light Linearity) dimming, Cpulse™ Pulse Width Modulation control and AirLOC™ (Less Optical Cleaning) technology greatly reducing the level of particles drawn over optics to increase performance and time spent between cleaning, you have all the extra technologies that sets the LedPOINTE® apart from the rest.

All these features, technologies and effects packaged into a compact 21 kg housing make LedPOINTE® the ultimate choice for LED all-in-one fixtures.

LedPOINTE® - Spot, Beam, Wash and FX superiority

Source

- TE™ 280W XP White LED Engine (Patented)
- XP - Xtra Performance Engine for maximum light output and optimal colour characteristics
- LED Engine output: 19.300 lm
- Fixture total lumen output: 11.750 lm (integrating sphere)
9.400 lm (goniophotometer)
- Colour temperature output: 6.700 K
- CRI: 70
- Illuminance: 162.000 lux @ 5 m
- Typical lumen maintenance: L70/B50 @ 50.000 hours
- LED life expectancy: min. 50.000 hours
- Light source warranty: 4 years or 20.000 hours

Optical System

- Robe's proprietary optical design: 2:1 hot-spot
- Zoom range: 1.8°-44°
- Output lens diameter: 155 mm

Dynamic Effects and Features

- Cyan: 0-100 %
- Magenta: 0-100 %
- Yellow: 0-100 %
- Virtual CTO: 3.000K - 6.700K
- ChromaTint™ - Patented plus / minus green correction function
- Colour Wheel: 13 dichroic filters + white
- Rotating gobo wheel: 9 rotating, indexable and replaceable breakup and aerial gobos + open, patented slot & lock system
- Static gobo wheel: 11 gobos + open
- MLP™ - Patented Multi-Level Prisms allow multiple prisms to be "stacked" while retaining individual speed and direction control. With variable shape and size it creates unlimited dynamic, multi-level flower and beam effects:
- Prism wheel 1: Independent 6 facet linear prism rotating in both directions at variable speed and Independent 18 facet circular prism rotating in both directions at variable speed
- Prism wheel 2: SpektraBeam™ effect rotating in both directions at variable speed and Independent 8 facet circular prism rotating in both directions at variable speed
- MagFrost™: magnetic paddle fast change system providing exchangeable frosts containing as standard a very light 1°

- for instant softening of the projected gobo or framing shutters, and a medium 5° for even wash, both specifically selected for theatre and TV use
- Motorised zoom and focus
- Pre-programmed random strobe & pulse effects
- Dimmer: 0-100%
- DataSwatch™ filters: pre-programmed 237 colours and tones including most used whites 2.700K, 3.200K, 4.200K, 5.600K and 8.000K
- L3™ - (Low Light Linearity) Imperceptible 18 bit dimming for ultra smooth fade to black
- Cpulse™ special flicker-free management for HD and UHD cameras, ready for 8K and 16K
- AirLOC™ (Less Optical Cleaning) technology greatly reduces the level of airborne particles drawn over the optical elements. This increases the overall performance, light quality and time between routine cleaning and maintenance.
- SpektraBeam™ - Paradigm-shifting patented effects engine. See it to believe it. The true, monumental breakthrough in effects modules

Control and Programming

- Setting & Addressing: ROBE Navigation System 3 (RNS3)
- Display: QVGA Robe screen with battery backup, gravitation sensor for auto screen positioning, operation memory service log with RTC, built-in analyser for easy fault finding
- Protocols: USITT DMX-512, RDM
ArtNet, MA Net, MA Net2, sACN
- REAP™ - Robe Ethernet Access Portal
- Wireless CRMX™ technology from Lumen Radio - on request
- Epass™: Ethernet pass through switch which sustains Ethernet integrity, when the fixture has no power, to automatically maintain network connectivity - on request
- DMX Protocol modes: 1
- Control channels: 38
- Pan & Tilt resolution: 8 or 16 bit
- Colour wheel positioning: 8 or 16 bit
- Rotating gobo wheel positioning: 8 bit
- Static gobo wheel positioning: 8 bit

- Gobo indexing & rotation: 8 or 16 bit
- Prism indexing & rotation: 8 bit
- Frost: 8 bit
- Zoom: 8 or 16 bit
- Focus: 8 or 16 bit
- Dimmer: 8 or 16 bit

Movement

- Pan movement: 540° with continuous rotation control
- Tilt movement: 270°
- Controllable speed of Pan & Tilt movement
- EMS™: Electronic Motion Stabilizer system for Pan & Tilt reducing beam deviation caused by truss movement or vibration (Patented)

Rotating Gobos

- Glass gobos: 9 rotating gobos
- Outside diameter: 15.9 mm
- Image diameter: 12.5 mm
- Thickness: 1.1 mm
- High temperature borofloat or better glass
- Patented slot & lock system for easy replacement of gobos

Static Gobos

- Aluminium wheel with 11 fixed gobos + open position

Thermal Specification

- Maximum ambient temperature: 45 °C (113 °F)
- Maximum surface temperature: 90 °C (194 °F)
- Minimum operating temperature: -5 °C (23 °F)

Electrical Specification and Connections

- Power supply: Electronic auto-ranging
- Input voltage range: 100-240 V, 50/60 Hz
- Power consumption: 400 W at 230 V / 50 Hz
- Power connector in/out: Neutrik powerCON TRUE1 in/out
- DMX and RDM data in/out: Locking 5-pin XLR
- Ethernet port in/out: RJ45 for Embedded Epass™ switch 10/100 Mbps - on request



Approvals

- CE Compliant
- cETLus Compliant

Mechanical specification

- Height: 667 mm (26.25") - head in vertical position
- Width: 363 mm (14.29")
- Depth: 240 mm (9.44") - head in vertical position
- Weight: 21 kg (46.30 lbs)
- Ingress protection rating: IP20

Rigging

- Mounting points: 2 pairs of 1/4-turn locks
- 2x Omega adaptors with 1/4-turn quick locks

- Universal operating position
- Pan & Tilt transport locks
- Safety cable attachment point

Included Items

- User Manual
- Omega Adaptor CL-regular 2 pcs: 10980033
- Power cord including powerCON TRUE1 In connector

Optional Accessories

- Frost 0.5° (exchange) assembled: 10980690
- Frost 1° (exchange) assembled: 10980691
- Frost 3.5° (exchange) assembled: 10980758

- Frost 10° (exchange) assembled: 10980693
- Frost 20° (exchange) assembled: 10980694
- Frost 30° (exchange) assembled: 10980695
- Doughty Trigger Clamp: 17030386
- Safety wire 36 kg: 99011963
- Single Top Loader Case: 10120365
- Dual Top Loader Case: 10120366
- Quad Top Loader Case: 10120367
- Foam Shell: 20020506

Legal

- LedPOINTE® is Registered Trademark of Robe lighting s. r. o.
- LedPOINTE® is patented by Robe lighting s. r. o. and is protected by one or more pending or issued patents

Colour wheel

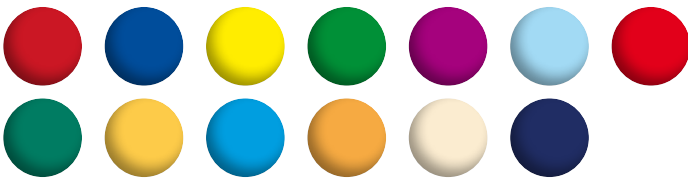

CMY Colour Mixing system:



Rotating gobo wheel



Static gobo wheel



IN-Air Effects

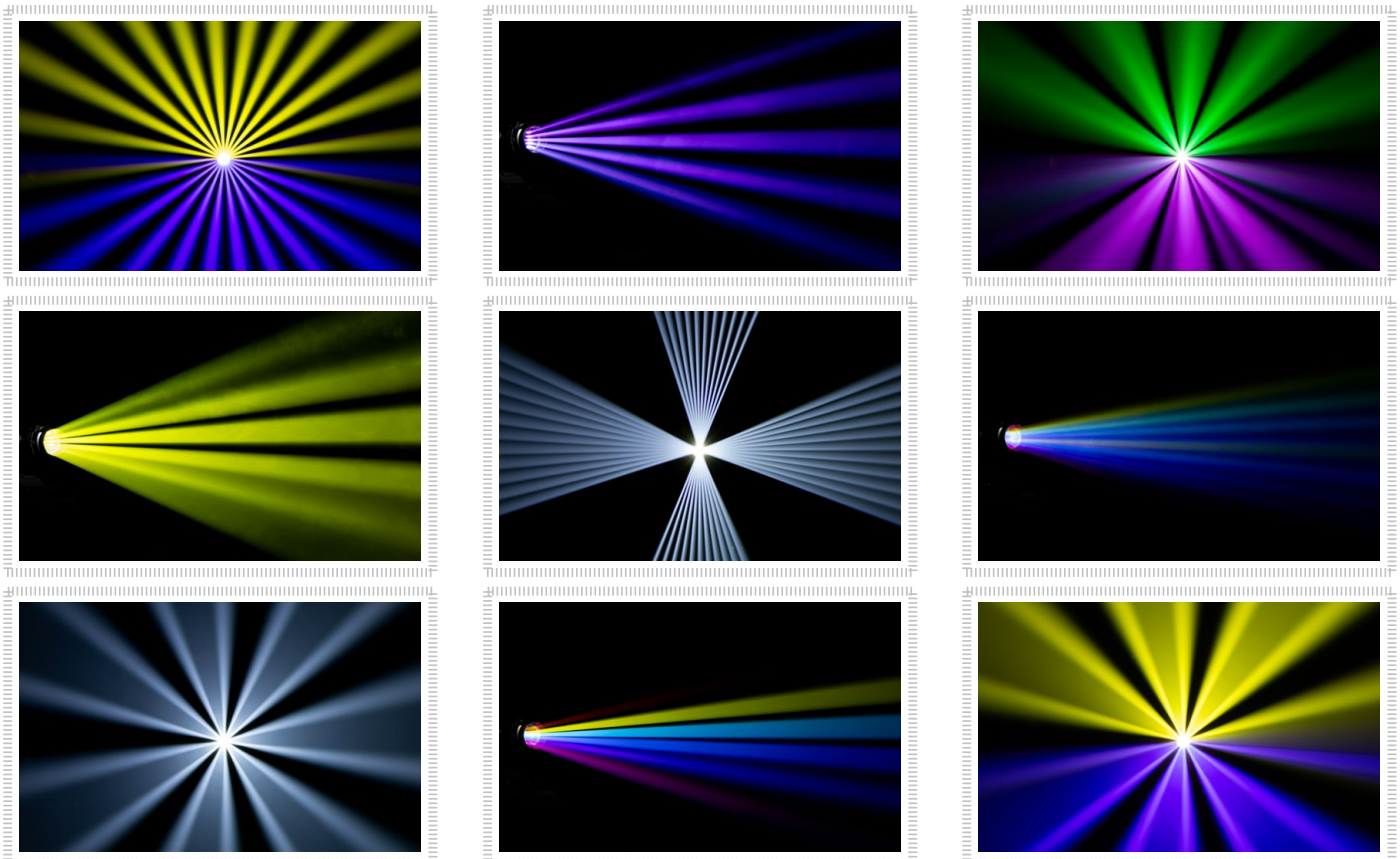

LedPOINT[®]

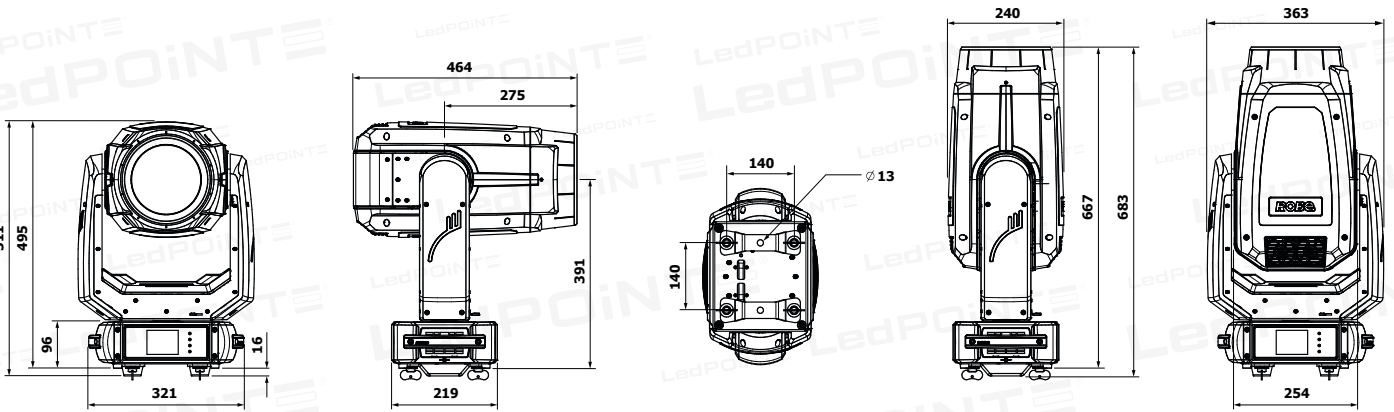

LedPOINT[®]



www.robe.cz



Head office: ROBE lighting s. r. o. | Házovice 2090 | 756 61 Rožnov pod Radhoštěm | Czech Republic

Factory: ROBE lighting s. r. o. | Palackého 416 | 757 01 Valašské Meziříčí | Czech Republic

Tel.: +420 571 751 500 | E-mail: robe@robe.cz

December 2024 © ROBE lighting s. r. o. All specifications subject to change without notice.