

BT-PROFILE 500TW LED ENGINE



ENGLISH Operation Manual

Other languages can be downloaded from:
WWW.BRITEQ-LIGHTING.COM



Version: 1.0





EN - DISPOSAL OF THE DEVICE

Dispose of the unit and used batteries in an environment friendly manner according to your country regulations.

FR - DÉCLASSER L'APPAREIL

Débarrassez-vous de l'appareil et des piles usagées de manière écologique conformément aux dispositions légales de votre pays.

NL - VERWIJDEREN VAN HET APPARAAT

Verwijder het toestel en de gebruikte batterijen op een milieuvriendelijke manier conform de in uw land geldende voorschriften.

DU - ENTSORGUNG DES GERÄTS

Entsorgen Sie das Gerät und die Batterien auf umweltfreundliche Art und Weise gemäß den Vorschriften Ihres Landes.

ES - DESHACERSE DEL APARATO

Reciclar el aparato y pilas usadas de forma ecologica conforme a las disposiciones legales de su país.

PT - COMO DESFAZER-SE DA UNIDADE

Tente reciclar a unidade e as pilhas usadas respeitando o ambiente e em conformidade com as normas vigentes no seu país.

OPERATION MANUAL

Thank you for buying this BRITEQ® product. To take full advantage of all possibilities and for your own safety, please read these operating instructions very carefully before you start using this unit.

FEATURES

- This LED profile spot is based on high power LED technology.
- It's a perfect companion to our BT-THEATRE 400TW
- For your convenience the projector is sold as two separate parts:
 - **BT-PROFILE 500TW/LED ENGINE**
 - Equipped with a high power tunable white COB LED (2800K-6000K)
 - Extremely silent cooling system using heat pipe technology
 - Compatible with ETC® Source Four-optics
 - LCD-screen for easy settings.
 - 5 working modes:
 - Manual control over intensity and CCT
 - 4 different DMX modes with 8 or 16bit dimming and CCT control
 - Different dimmer curves:
 - Linear
 - Square law
 - Inverse square law
 - S-curve
 - **DIFFERENT OPTICS:**
 - Specially coated optics for sharply defined crisp projections
 - Four profile blades, specially coated for minimum reflections
 - Different optical units are available:
 - BT-PROFILE250/OPTIC 19DEG - fixed 19° beam angle (*order code: 6024*)
 - BT-PROFILE250/OPTIC 26DEG - fixed 26° beam angle (*order code: 6025*)
 - BT-PROFILE250/OPTIC 36DEG - fixed 36° beam angle (*order code: 6026*)
 - BT-PROFILE250/OPTIC 50DEG - fixed 50° beam angle (*order code: 6027*)
 - BT-PROFILE160/OPTIC 15-30 - 15°-30° zoom range (*order code: 6001*)
 - BT-PROFILE160/OPTIC 25-50 - 25°-50° zoom range (*order code: 6002*)
 - Lockable compartment for use of the optionally available:
 - **GOBO Holder** ("BT-PROFILE160/GOBO HOLDER", order code: 6003)
Outer diameter gobos: 86mm, optical diameter: 48mm
 - **IRIS** ("BT-PROFILE160/IRIS", order code: 6004)
Aperture diameter: adjustable from 5mm to 74mm
 - Can replace ETC Source Four-optics
 - Optical barrel can be rotated and locked I any position

BEFORE USE

- Before you start using this unit, please check if there's no transportation damage. Should there be any, do not use the device and consult your dealer first.
- **Important:** This device left our factory in perfect condition and well packaged. It is absolutely necessary for the user to strictly follow the safety instructions and warnings in this user manual. Any damage caused by mishandling is not subject to warranty. The dealer will not accept responsibility for any resulting defects or problems caused by disregarding this user manual.
- Keep this booklet in a safe place for future consultation. If you sell the fixture, be sure to add this user manual.

Check the contents:

Check that the carton contains the following items:

- User manual
- BT-PROFILE 500TW LED ENGINE
- Power cable

SAFETY INSTRUCTIONS:



CAUTION
RISK OF ELECTRIC SHOCK
DO NOT OPEN



CAUTION: To reduce the risk of electric shock, do not remove the top cover. No user-serviceable parts inside. Refer servicing to qualified service personnel only.



The lightning flash with arrowhead symbol within the equilateral triangle is intended to alert the user or the presence of un-insulated "dangerous voltage" within the product's enclosure that may be of sufficient magnitude to constitute a risk of electric shock.



The exclamation point within the equilateral triangle is intended to alert the user to the presence of important operation and maintenance (servicing) instructions in the literature accompanying this appliance.



This symbol means: indoor use only



This symbol means: Read instructions



This symbol means: Safety Class I appliance



This symbol determines: the minimum distance from lighted objects. The minimum distance between light-output and the illuminated surface must be more than 1 meters



The device is not suitable for direct mounting on normally flammable surfaces. (suitable only for mounting on non-combustible surfaces)

RISK GROUP 2
CAUTION:
Do not stare at operating lamp

CAUTION: Do not stare at operating lamp.
May be harmful to the eyes.

- To protect the environment, please try to recycle the packing material as much as possible.
- To prevent fire or shock hazard, do not expose this appliance to rain or moisture.
- To avoid condensation to be formed inside, allow the unit to adapt to the surrounding temperatures when bringing it into a warm room after transport. Condense sometimes prevents the unit from working at full performance or may even cause damages.
- This unit is for indoor use only.
- Don't place metal objects or spill liquid inside the unit. Electric shock or malfunction may result. If a foreign object enters the unit, immediately disconnect the mains power.
- Locate the fixture in a well ventilated spot, away from any flammable materials and/or liquids. The fixture must be fixed at least 50cm from surrounding walls.
- Don't cover any ventilation openings as this may result in overheating.
- Prevent use in dusty environments and clean the unit regularly.
- Keep the unit away from children.
- Inexperienced persons should not operate this device.
- Maximum safe ambient temperature is 40°C. Don't use this unit at higher ambient temperatures.
- Make sure the area below the installation place is free from unwanted persons during rigging, de-rigging and servicing.
- Allow the device about 10 minutes to cool down before to start servicing.
- Always unplug the unit when it is not used for a longer time or before to start servicing.
- The electrical installation should be carried out by qualified personal only, according to the regulations for electrical and mechanical safety in your country.
- Check that the available voltage is not higher than the one stated on the unit.
- The power cord should always be in perfect condition. Switch the unit immediately off when the power cord is squashed or damaged. It must be replaced by the manufacturer, its service agent or similarly qualified persons in order to avoid a hazard.
- Never let the power-cord come into contact with other cables!
- This fixture must be earthed in order to comply with safety regulations.
- Don't connect the unit to any dimmer pack.
- Always use an appropriate and certified safety cable when installing the unit.
- In order to prevent electric shock, do not open the cover. There are no user serviceable parts inside.

- **Never** repair a fuse or bypass the fuse holder. **Always** replace a damaged fuse with a fuse of the same type and electrical specifications!
- In the event of serious operating problems, stop using the fixture and contact your dealer immediately.
- The housing and the lenses must be replaced if they are visibly damaged.
- Please use the original packing when the device is to be transported.
- Due to safety reasons it is prohibited to make unauthorized modifications to the unit.

Important: Never look directly into the light source! Don't use the effect in the presence of persons suffering from epilepsy.

OVERHEAD RIGGING

The projector can be put on any stable projector stand or you can hang it on the wall or ceiling. In that case please follow the safety instructions below to assure proper installation!

- **Important:** The installation must be carried out by qualified service personal only. Improper installation can result in serious injuries and/or damage to property. Overhead rigging requires extensive experience! Working load limits should be respected, certified installation materials should be used, the installed device should be inspected regularly for safety.
- Make sure the area below the installation place is free from unwanted persons during rigging, de-rigging and servicing.
- Locate the fixture in a well ventilated spot, far away from any flammable materials and/or liquids. The fixture must be fixed **at least 50cm** from surrounding walls.
- The device should be installed out of reach of people and outside areas where persons may walk by or be seated.
- Before rigging make sure that the installation area can hold a minimum point load of 10times the device's weight.
- Always use a certified safety cable that can hold 12 times the weight of the device when installing the unit. This secondary safety attachment should be installed in a way that no part of the installation can drop more than 20cm if the main attachment fails.
- The device should be well fixed; a free-swinging mounting is dangerous and may not be considered!
- Don't cover any ventilation openings as this may result in overheating.
- The operator has to make sure that the safety-relating and machine-technical installations are approved by an expert before using them for the first time. The installations should be inspected every year by a skilled person to be sure that safety is still optimal.

DESCRIPTION:

1. **DISPLAY:** Helps you with the configuration of the LED ENGINE. The backlight of the display starts flashing while the projector is in DMX-mode and no DMX is detected.
2. **MENU button:** used to browse the setup menu, with each button press you go to the next item.
3. **UP button:** used to change (increase) the value of the selected feature.
4. **DOWN buttons:** used to change (decrease) the value of the selected feature.
5. **ENTER button:** used to confirm the selected selection, don't forget!
6. **Manual knob:** used to adjust the intensity and CCT when in manual mode. Press short to switch between Dimmer and CCT, press and hold for 5s to save the settings to memory.
7. **MAINS FUSE:** protects the unit in case of electrical problems, always use the prescribed fuse!
8. **MAINS INPUT:** with PowerCON® socket; connect the supplied mains cable here.
9. **MAINS OUTPUT:** you can use this output to daisy chain several units, up to max 16A. Input and output are connected to each other without any fuse.

Hint: Please check our website for special cable assemblies that contain both power (3x1.5mm² with Neutrik PowerCON®) and balanced signal (XLR 3pin) in one cable. Different lengths are available: 1.3m, 3m, 5m and 10m, very convenient!



10. **DMX INPUT CONNECTOR:** 3pin male XLR-connector used to connect the unit with the DMX controller or with the previous unit in the DMX chain.
11. **DMX OUTPUT:** 3pin female XLR-connector used to connect the unit with the next unit in the DMX chain.
12. **SECURITY KNOBS FOR OPTICS:** 2 knobs to prevent that the OPTICS can come loose from the LED ENGINE. To change the optics you should loosen both knobs, see further instructions in the next chapter. To simply turn the optics over a certain angle, you only have to loosen both knobs a little.

INSTALLING THE OPTICS

For maximum flexibility the LED ENGINE and OPTICS are sold separately. Also you can install optics from some other brands which even increases flexibility for professional rental companies. In this chapter we describe how to install/exchange the optics on the LED ENGINE.



- A. Loosen the 2 security knobs (12) so it will be possible to fix the optics on the led engine.
 - B. On the LED ENGINE you will notice 4 bulges (A)
 - C. On the OPTICS you will see 4 notches (B)
 - D. Take the OPTICS and turn it over about 45° so the 4 bulges (A) and 4 notches (B) are facing each other and the two parts fit into each other.
 - E. Now rotate the OPTICS over about 45°: both parts are now joined together.
 - F. Fasten the 2 security knobs (12) to assure that both parts stay together, also while turning the optics.
- Remark:** in the beginning it needs some practice to install and remove the optics on the LED Engine, after a while it will be a piece of cake for you!

OPERATING INSTRUCTIONS / SETUP MENU

The light output of the projector can be controlled manually or via DMX. Below we explain you the different functions of the setup menu:

DMX Addr	001(002)
CH. Mode	1Ch 8b
	2Ch 8b
	3Ch 16b
	4Ch 16b
Dimcurve	Linear
	Square
	I.Square
	S-Curve
LED CCT	2800K
	3000K
	3200K
	4000K
	4300K
	5600K
No DMX	6000K
	Freeze
	Blackout
Firmware	Dim: xxx%
	CCT: xxxK

DMX Address (DMX Addr)

Set the DMX address and use the projector in DMX-mode.

- Press the MENU-button (2) until the display shows “DMX Addr”
 - Press the UP/DOWN buttons (3&4) to set the desired DMX address.
 - Press the ENTER button (5) to confirm.
- ⇒ The display shows the DMX-address while the projector is now in working in DMX-mode.

CH. Mode

Used to select if the dimmer should work in 8bit or 16bit mode while controlled via DMX.

- Press the MENU-button (2) until the display shows [Ch. Mode]
- Press the UP/DOWN buttons (3&4) to select one of the 2 options:
 - 1CH 8b: Single 8bit dimmer control
 - 2Ch 8b: 8bit dimmer with color control
 - 3Ch 16b: 16bit dimmer with color control
 - 4ch 16bS: 16bit dimmer with color and shutter control
- Press the ENTER button (5) to confirm.

Dimmer behavior (DimCurve)

Used to select the behavior of the dimmer (dimmer curve).

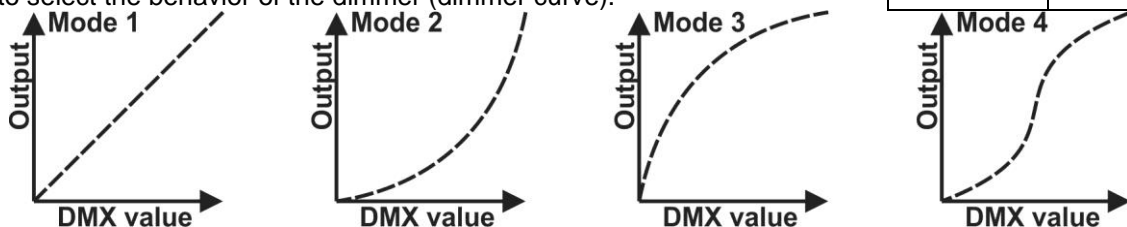

- Press the MENU-button (2) until the display shows [Dimcurve]
- Press the UP/DOWN buttons (3&4) to select one of the 4 available curves (see drawings):
 - **[Linear]** (Mode 1): light output varies linearly with the dimmer value
 - **[Square]** (Mode 2): light output can be adjusted more accurately for low dimmer values
 - **[InvSquare]** (Mode 3): light output can be adjusted more accurately for high dimmer values.
 - **[S-Curve]** (Mode 4): light output can be adjusted more accurately for both high and low dimmer values.
- Press the ENTER button (5) to confirm

LED color (LED CCT)

Used to select the desired color of the projector

- Press the MENU-button (2) until the display shows [LED CCT]
- Press the UP/DOWN buttons (3&4) to select one of the LED color temperatures
- Press the ENTER button (5) to confirm

No DMX

Used to select how the projector should react when DMX is lost

- Press the MENU-button (2) until the display shows [No DMX]
- Press the UP/DOWN buttons (3&4) to select one of the 3 options:
 - Freeze: Hold the last received DMX value when DMX is lost

- Blackout: Turns off the projector when DMX is lost
- Manual: Enables the knob for manual adjustments and loads the dimmer and CCT settings from memory.
- Press the ENTER button (5) to confirm.

Firmware version (Ver.)

Shows the actual version of the controller.

- Press the MENU-button (2) until the display shows "Ver."
- ⇒ The display shows the actual firmware version.

Some extra safety remarks:

- Always unplug the unit when it is not used for a longer time or before to start servicing.
- In the event of serious operating problems, stop using the fixture and contact your dealer immediately.
- **Important:** Never look directly into the light source! Don't use the strobe function in the presence of persons suffering from epilepsy.

ELECTRICAL INSTALLATION



Important: The electrical installation should be carried out by qualified personal only, according to the regulations for electrical and mechanical safety in your country.

Electrical installation for two or more units in DMX-mode:

- The DMX-protocol is a widely used high speed signal to control intelligent light equipment. You need to "daisy chain" your DMX controller and all the connected units.
- Pin layout XLR-3pin: Pin1 = GND ~ Pin2 = Negative signal (-) ~ Pin3 = Positive signal (+)
- To prevent strange behavior of the light effects, due to interferences, you must use a 90Ω to 120Ω terminator at the end of the chain. Never use Y-splitter cables, this simply won't work!
- Make sure that all units are connected to the mains.
- Each unit in the chain needs to have its proper starting address so it knows which commands from the controller it has to decode.

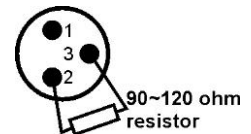

USE IN STAND-ALONE (STATIC) MODE

- In the setup menu: select [No DMX] and choose the option [Dim:xxx CCT:xxx]
- Now you can set the desired output manually:
 - **Set the desired light output:** choose the option [DIMMER]
 - **Set one of the CCT presets:** choose [LED CCT] and select one of the CCT-presets

Remark: if you don't use the preset options, both should be set to "NONE" to select any desired color.

DMX CHARTS

1CH 8b	2CH 8b	3CH 16b	4CH 16bS	VALUES	FUNCTION	Defaults
1	1	1	1	000-255	Dimmer coarse (0-100%)	0/0
-	-	2	2	000-255	Dimmer fine (16bit)	
-	2	3	3	000-009	CCT = 2800K	25
				010-018	CCT = 3000K	
				019-027	CCT = 3200K	
				028-036	CCT = 4000K	
				037-045	CCT = 4300K	
				046-054	CCT = 5600K	
				055-063	CCT = 6000K	
				064-255	Linear CCT from 2800K to 6000K	
-	-	-	4	000-005	Open (no strobe)	0
				006-125	Normal strobe (slow → fast)	
				126-135	Open (no strobe)	
				136-255	Random strobe (slow → fast)	

MAINTENANCE

- Make sure the area below the installation place is free from unwanted persons during servicing.
- Switch off the unit, unplug the mains cable and wait until the unit has been cooled down.

During inspection the following points should be checked:

- All screws used for installing the device and any of its parts should be tightly fastened and may not be corroded.
- Housings, fixations and installations spots (ceiling, truss, suspensions) should be totally free from any deformation.
- When an optical lens is visibly damaged due to cracks or deep scratches, it must be replaced.
- The mains cables must be in impeccable condition and should be replaced immediately when even a small problem is detected.
- In order to protect the device from overheat the cooling fans and ventilation openings should be cleaned monthly.
- The interior of the device should be cleaned periodically using a vacuum cleaner or air-jet.
- The cleaning of internal and external optical lenses must be carried out periodically to optimize light output. Cleaning frequency depends on the environment in which the fixture operates: damp, smoky or particularly dirty surroundings can cause greater accumulation of dirt on the unit's optics.

Attention: We strongly recommend internal cleaning to be carried out by qualified personnel!

SPECIFICATIONS

This unit is radio-interference suppressed. This product meets the requirements of the current European and national guidelines. Conformity has been established and the relevant statements and documents have been deposited by the manufacturer.

Mains Input:	110-240Vac 50/60Hz
Power consumption:	350 Watt at max output
Fuse:	250V 3A slow blow (20mm glass)
Power connections:	Powercon input + output
DMX connections:	3pin XLR male / female
DMX channels used:	1, 2, 3, 4ch
Lamp:	500W COB LED-engine white 2800K-6000K, CRI> 96
Size:	310 x 250 x 350mm (led engine without bracket and without lens)
Weight:	4.83 kg (LED ENGINE)

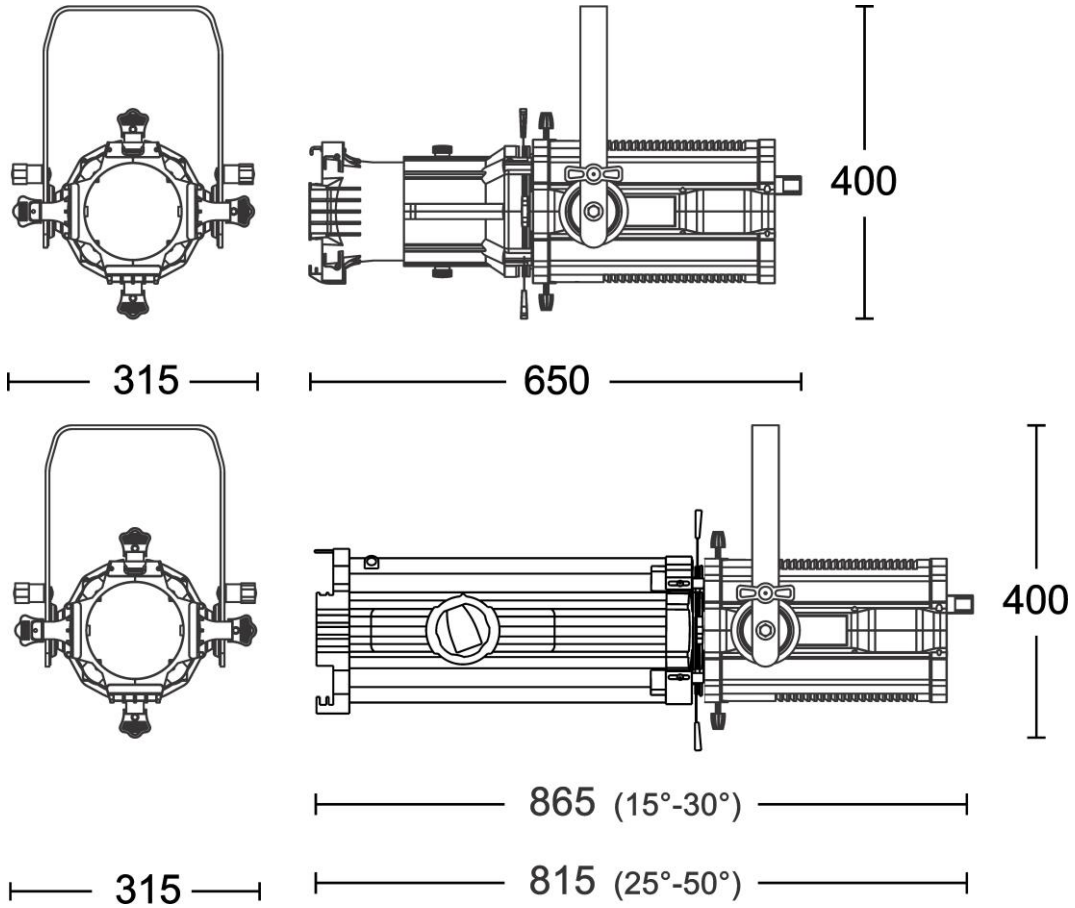

The information might be modified without prior notice
You can download the latest version of this user manual on our website: www.briteq-lighting.com



MAILING LIST

EN: Subscribe today to our mailing list for the latest product news!

FR: Inscrivez-vous à notre liste de distribution si vous souhaitez suivre l'actualité de nos produits!

NL: Abonneer je vandaag nog op onze mailinglijst en ontvang ons laatste product nieuws!

DE: Abonnieren Sie unseren Newsletter und erhalten Sie aktuelle Produktinformationen!

ES: Suscríbete hoy a nuestra lista de correo para recibir las últimas noticias!

PT: Inscreva-se hoje na nossa mailing list para estar a par das últimas notícias!

WWW.BRITEQ-LIGHTING.COM

Copyright © 2024 by BEGLEC NV

't Hofveld 2C ~ B1702 Groot-Bijgaarden ~ Belgium

Reproduction or publication of the content in any manner, without express permission of the publisher, is prohibited.