

ROBE

ROBIN[®] T.5

Profile

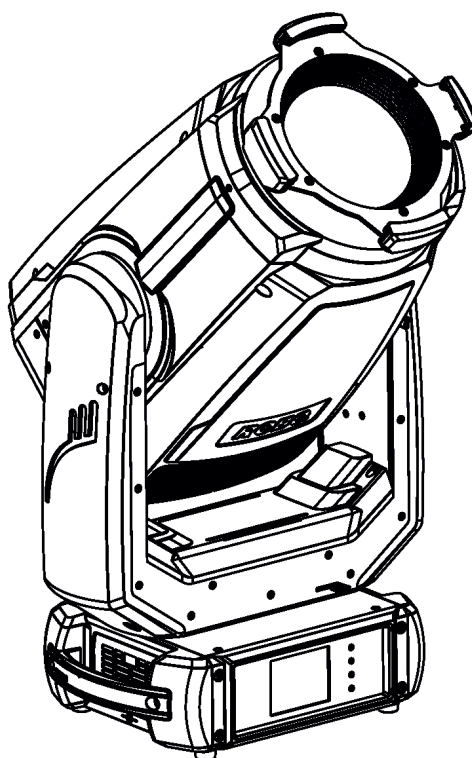

 **ROBIN[®]**
Innovative Technology

QR code for user manual



USER MANUAL

ROBE[®] lighting s.r.o. • Czech Republic • www.robe.cz

Version 1.0

Robin T.5 Profile

Table of contents

1. Safety instructions	3
2. Operating determination	4
3. Fixture exterior view	6
4. Installation	7
4.1 Connection to the mains	7
4.2 Replacing the frost	8
4.3 Replacing rotating gobos	9
4.4 Rigging the fixture	11
4.5 DMX-512 connection.....	13
4.6 Ethernet connection	14
4.7 Wireless DMX operation	16
5. Remotely controllable functions	17
5.1 Colour influencing functions	17
5.2 Effect functions.....	20
6. Control menu map	22
7. Control menu	27
7.1 Tab "Address"	28
7.2 Tab "Information"	29
7.3 Tab "Personality"	31
7.4 Tab "Manual Control".....	34
7.5 Tab "Stand-alone"	34
7.6 Tab "Service"	35
8. RDM	39
9. Error and information messages	40
10. Robe Ethernet Access Portal (REAP)	43
11. Technical Specifications	44
12. Maintenance and cleaning	48
12.1 Disposing of the product	49
13. ChangeLog	49

CAUTION!
Keep this device away from rain and moisture!
Unplug mains lead before opening the housing!

**FOR YOUR OWN SAFETY, PLEASE READ THIS USER MANUAL CAREFULLY
BEFORE YOU INITIAL START - UP!**

1. Safety instructions

CAUTION!
Be careful with your operations.
With a high voltage you can suffer
a dangerous electric shock when touching the wires!

This device has left our premises in absolutely perfect condition. In order to maintain this condition and to ensure a safe operation, it is absolutely necessary for the user to follow the safety instructions and warning notes written in this manual.

The manufacturer will not accept liability for any resulting damages caused by the non-observance of this manual or any unauthorized modification to the device.

Please consider that damages caused by manual modifications to the device are not subject to warranty.

Make sure that the area below the installation place is blocked when rigging, de-rigging or servicing the fixture.

Always fix the fixture with an appropriate safety wire. Fix the safety wire at the correct holes only.

Make sure that the available voltage is not higher than stated on the rear panel.

WARNING! This unit does not contain an ON/OFF switch. Always disconnect power input cable to completely remove power from unit when not in use or before cleaning or servicing the unit.

Make sure that the power cord is never crimped or damaged by sharp edges. Check the device and the power cord from time to time.

Always disconnect from the mains, when the device is not in use or before cleaning it.

**This device falls under protection class I. Therefore it is essential to connect
the yellow/green conductor to earth.**

The electric connection, repairs and servicing must be carried out by a qualified employee.

Do not connect this device to a dimmer pack.

During the initial start-up some smoke or smell may arise. This is a normal process and does not necessarily mean that the device is defective.

Do not touch the device's housing bare hands during its operation (housing becomes hot)!

For replacement use fuses of same type and rating only.

LED light emission. Risk of eye injury.
***Do not look straight at the fixture's LED source during operation. The intense light
beam may damage your eyes.***

***Do not view the light output with optical instruments or any device that may concentrate the beam.
The light source contains blue LEDs.***

CAUTION! Risk group 2, RG-2



2. Operating determination

This device is a moving head for creating decorative effects and was designed for indoor use only. This device is for professional use only. It is not for household use.

If the device has been exposed to drastic temperature fluctuation (e.g. after transportation), do not switch it on immediately. The arising condensation water might damage your device. Leave the device switched off until it has reached room temperature.

Never lift the fixture by holding it at the projector-head, as the mechanics may be damaged. Always hold the fixture at the transport handles.

When choosing the installation-spot, please make sure that the device is not exposed to extreme heat, moisture or dust.

Only operate the fixture after having checked that the housing is firmly closed and all screws are tightly fastened.

The maximum ambient temperature 45°C must never be exceeded.

CAUTION!

The front lens has to be replaced when it is obviously damaged, so that its function is impaired, e. g. due to cracks or deep scratches!

Operate the device only after having familiarized with its functions. Do not permit operation by persons not qualified for operating the device. Most damages are the result of unprofessional operation!

Do not block the front objective lens with any object when the fixture is under operation.

The fixture housing never must be covered with cloth or other materials.

Please consider that unauthorized modifications on the device are forbidden due to safety reasons!

If this device will be operated in any way different to the one described in this manual, the product may suffer damages and the guarantee becomes void. Furthermore, any other operation may lead to dangers like short-circuit, burns, electric shock, burns etc.

CAUTION!

To avoid damage of the internal parts of the fixture head, never let the sunlight lights directly to the front lens , even when the fixture is not working !

The product (covers and cables) must not be exposed to a high frequency electromagnetic field higher than 3V/m.

Immunity of the equipment is designed according to the standard EN 55035 Electromagnetic compatibility of multimedia equipment - Immunity requirements.

Emission of the equipment complies with the standard EN55032 Electromagnetic compatibility of multimedia equipment – Emission Requirements according to class B.

Contains FCC ID: 2A6PL-DMXRDMRW001*

Contains IC: 29573-DMXRDMRW001*

* Wireless DMX version of the fixture only.

This device complies with part 15 of the FCC Rules. Operation is subject to the following two conditions: (1) This device may not cause harmful interference, and (2) this device must accept any interference received, including interference that may cause undesired operation.

Changes or modifications not expressly approved by the party responsible for compliance could void the user's authority to operate the equipment.

The [Device] wireless operation is safe and complies to RF Exposure requirements

This equipment has been tested and found to comply with the limits for a Class B digital device, pursuant to part 15 of the FCC Rules. These limits are designed to provide reasonable protection against harmful interference in a residential installation. This equipment generates, uses and can radiate radio frequency energy and, if not installed and used in accordance with the instructions, may cause harmful interference to radio communications. However, there is no guarantee that interference will not occur in a particular installation. If this equipment does cause harmful interference to radio or television reception, which can be determined by turning the equipment off and on, the user is encouraged to try to correct the interference by one or more of the following measures:

- Reorient or relocate the receiving antenna.
- Increase the separation between the equipment and receiver.
- Connect the equipment into an outlet on a circuit different from that to which the receiver is connected.
- Consult the dealer or an experienced radio/TV technician for help.

Please use only an original ROBE packaging (paper box, loader case or foam shell) for transporting the device, otherwise potential damage of the device during its transport will not subject to warranty.

3. Fixture exterior view

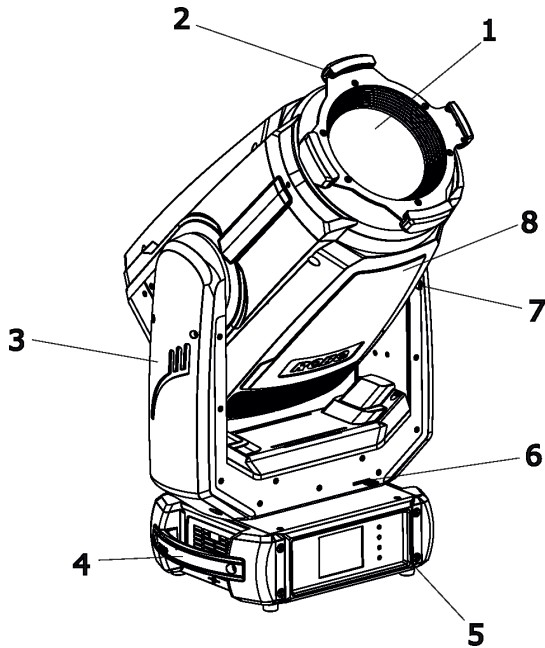

- 1 - Front lens
- 2 - Camera*
- 3 - Arm
- 4 - Handle
- 5 - Base
- 6 - Pan lock
- 7 - Tilt lock
- 8 - Head

The head has to be locked for transportation - the pan lock latch (6) and the tilt lock latch (7) have to be in the locked positions. To unlock the head, move these latches to unlock positions before operating the fixture.

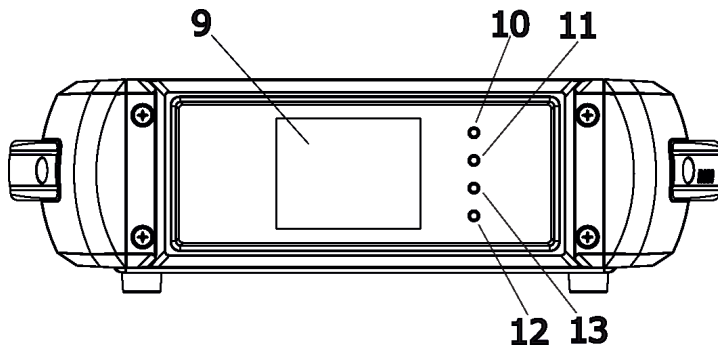

Front panel of the base

- 9 - QVGA touch screen
- 10 - ESCAPE button
- 11 - NEXT button
- 12 - ENTER/DISPLAY ON button
- 13 - PREV button

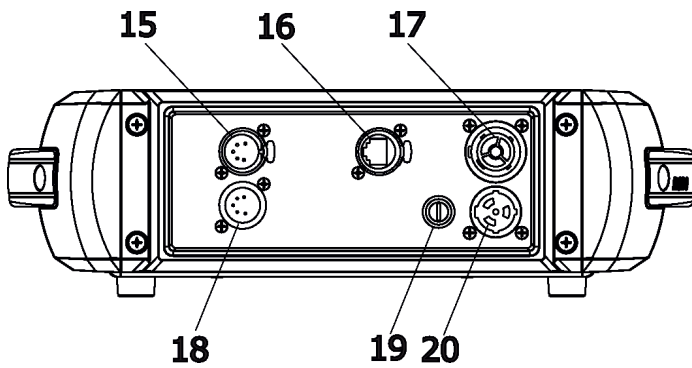

Rear panel of the base

- 15 - 5-pin DMX output (XLR)
- 16 - Ethernet input (RJ45)
- 17 - Power output (PowerCon True 1)
- 18 - 5-pin DMX input (XLR)
- 19 - Fuse holder
- 20 - Power input (PowerCon True 1)

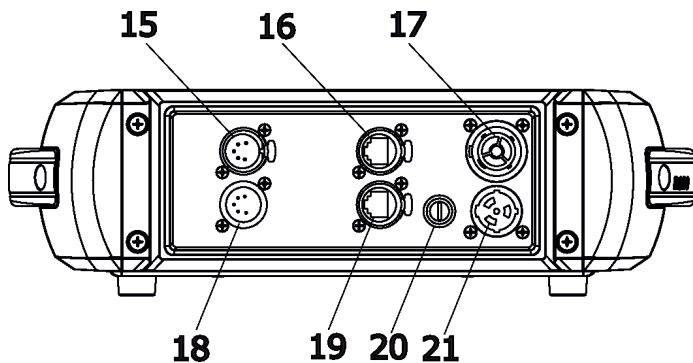

Rear panel of the base - EP version

- 15 - 5-pin DMX output (XLR)
- 16 - Ethernet output (RJ45)
- 17 - Power output (PowerCon True 1)
- 18 - 5-pin DMX input (XLR)
- 19 - Ethernet input (RJ45)
- 20 - Fuse holder
- 21 - Power input (PowerCon True 1)

The ENTER/DISPLAY ON button also serves for switching the display on when the fixture is disconnected from the mains.

4. Installation



Fixtures must be installed by a qualified electrician in accordance with all national and local electrical and construction codes and regulations.

4.1 Connection to the mains

For protection from electric shock, the fixture must be earthed!

The Robin T.5 Profile is equipped with auto-switching power supply that automatically adjusts to any 50-60Hz AC power source from 100-240 Volts.

Power cable is enclosed to the fixture. If you need to install a power plug on the power cable to allow connection to power outlets, install a grounding-type (earthed) plug, following the plug manufacturer's instructions. If you have any doubts about proper installation, consult a qualified electrician.

Core (EU)	Core (US)	Connection	Plug Terminal Marking
Brown	Black	Live	L
Light blue	White	Neutral	N
Yellow/Green	Green	Earth	

This device falls under class one and must be earthed (grounded).

To apply power, first check that the head pan and tilt locks are released.

Design of the ROBIN T.5 allows you to connect several fixtures (7 fixtures at 230V/16A circuit breaker; 3 fixtures at 120V/16 A circuit breaker) to AC mains power in one interconnected daisy chain using power input and throughput connector. Needed daisy chain cords are stated in the chapter "Technical specifications". Do not overload the supply line and connecting cables.

4.2 Replacing the frost

Unplug the fixture from mains before installing the frost module!

To replace the frost module.

1. Disconnect the fixture from mains and allow it to cool for 30 minutes.
2. Remove plastic cover of the head by loosening the 2 quarter-turn fasteners on the cover to get access to the frost module 5° (1).
3. Disconnect end of the spring (2) from the set screw (4).
4. The frost holder (3) is fastened to the movable part of the frost holder by means of magnets. Grip the frost holder (3) and carefully tilt it out to break a force of magnets.
5. Place a new frost module instead of the 5° frost module.
6. Connect end of the spring (2) to the set screw (4).
7. Place the plastic cover back on the fixture before applying power.

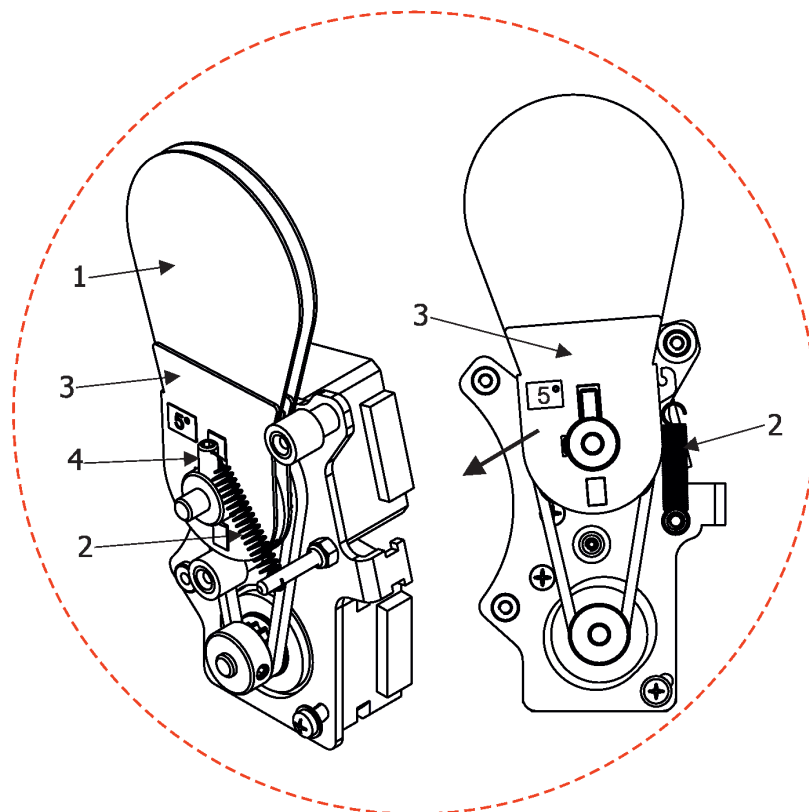
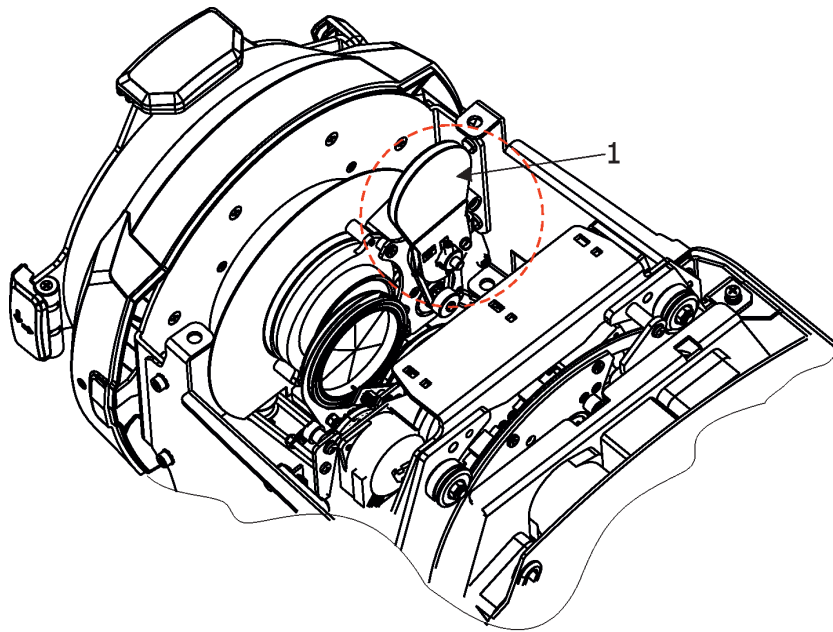

4.3 Replacing rotating gobos

Unplug the fixture from mains before replacing gobos!

- Put the fixture on the table and remove head plastic covers of the head by loosening the 2 quarter-turn fasteners on each cover.
- Connect the fixture to mains. Go to the tab "Service", select the menu "Adjust DMX values " and move the fixture head to the position which is intended for changing rot. gobos as shown on the picture below.

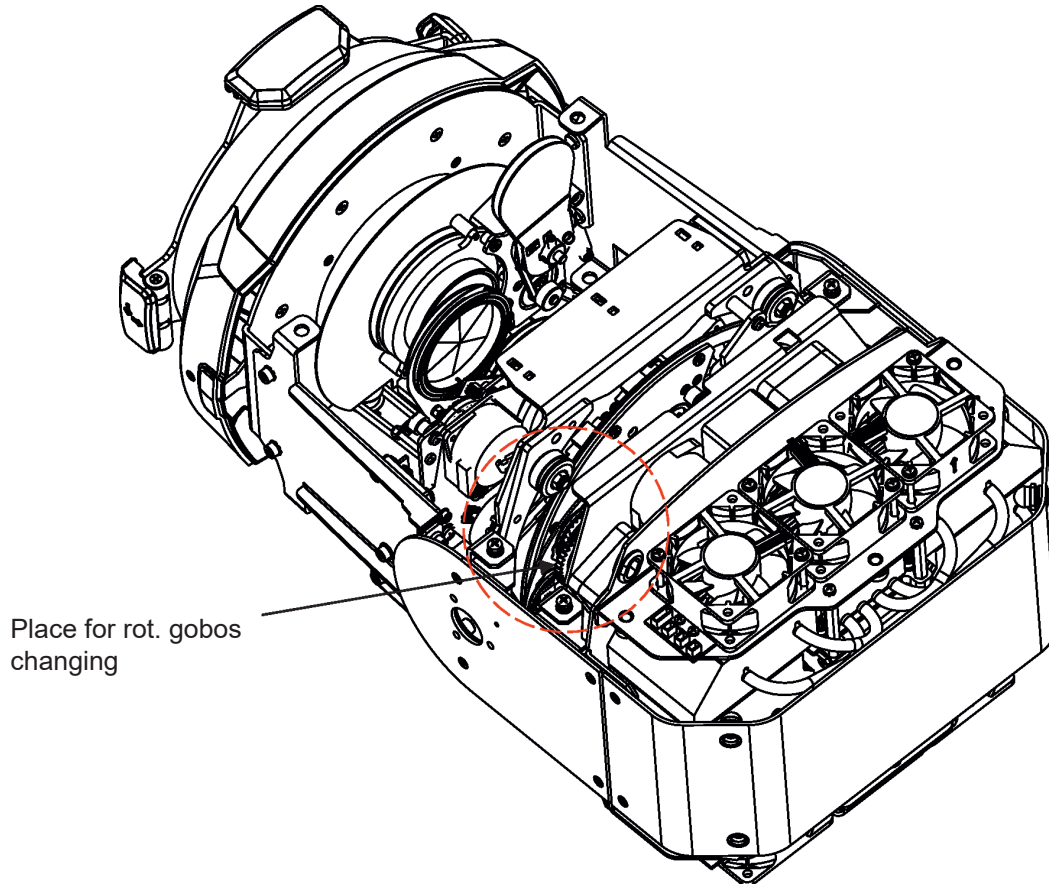

- Escape from the menu "Adjust DMX values " and go to the menu " Rotating Gobos Change" in the same tab, select Gobo Carousel 1 and enter to its menu.
- Select a gobo (G1-Mg, G2, G3, G4, G5, G6, G7) which you wish to replace. The selected gobo will move to the accessible position for its changing.
Note: "G1-Mg" means the gobo holder with a magnet.
- Check that the position point (4) on the gobo holder aims exactly to the toothlike projection (6) on the edge of the rotating gobo wheel. If not, go to the option "Gobo Offset" and adjust the position point (4) exactly opposite of the toothlike projection(6). Adjusted value in the "Gobo Offset" is valid for all gobos on the gobo carousel.
Note: The magnet (7) on the gobo holder substitutes the position point (4).

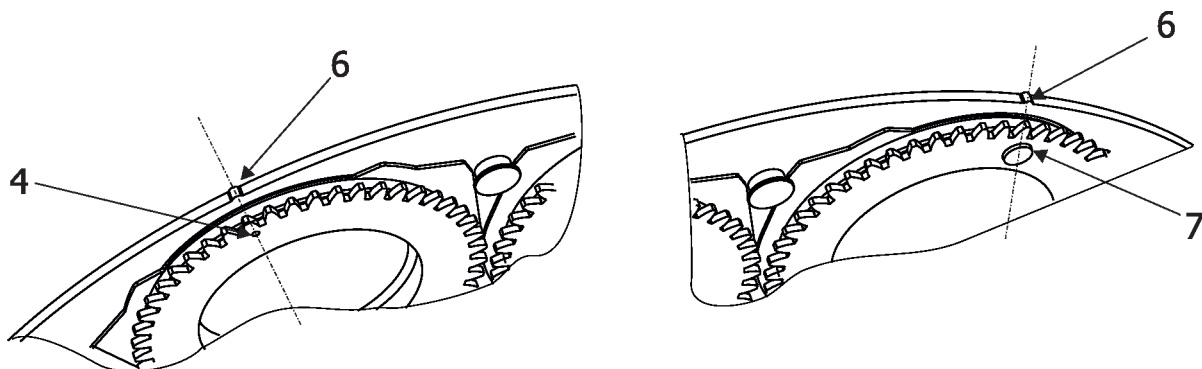

7. Gently pull up the gobo holder (3) from the rotation gobo carousel.
8. Remove the spring lock (1) with an appropriate tool (e.g. small-bladed screwdriver).
Do not touch the surface of the pattern of the glass gobo with bare fingers.
9. Remove the original gobo (2) and insert the new one (glossy side towards the light source, black matt side towards the front lens).
The Robe gobo has a small position point (5) at its edge which has to aim at the position point (4) on the gobo holder (3). Insert the spring lock (1) to secure correct gobo position in the gobo holder (3).

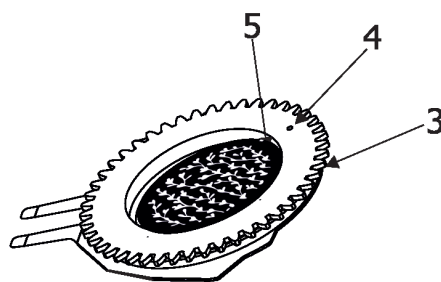
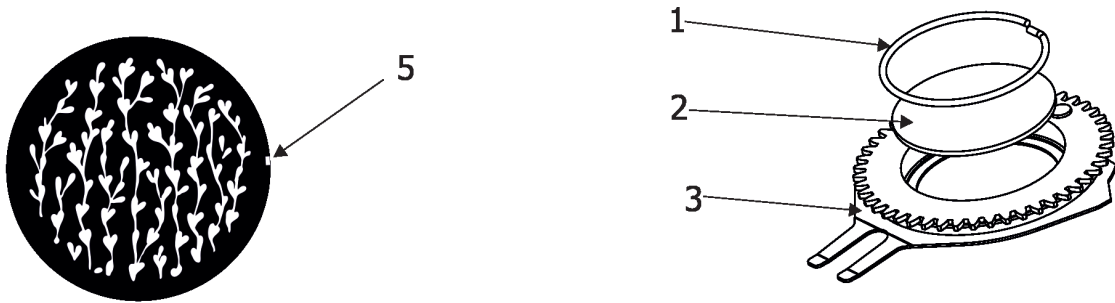

- 10 Insert the gobo holder back into gobo carousel in this way, that its position point (4) (or magnet (7) has to exactly aim at a small toothlike projection (6) on the edge of the rotating gobo wheel. Do not move with neighbouring gobo holders.

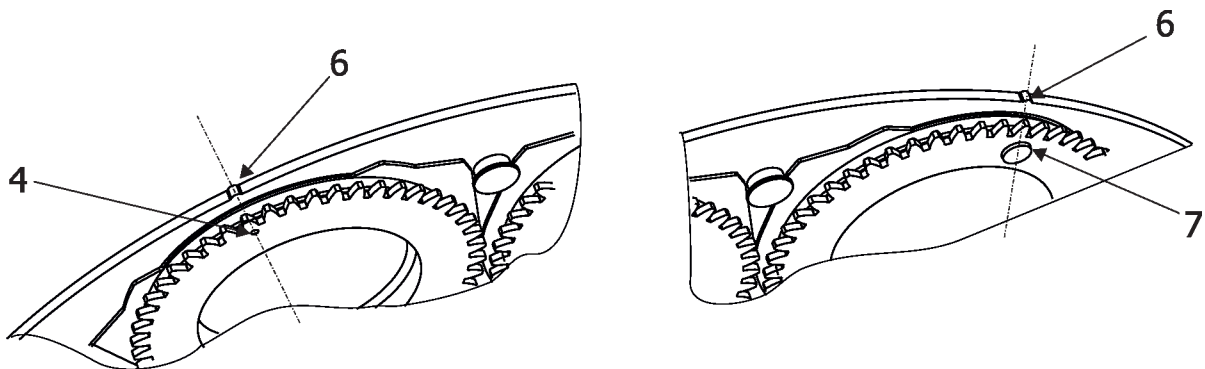

11. Escape the gobo item and enter another gobo item which you want to replace. You do not need to set the gobo offset again. Repeat steps 6, 8-12 for all gobos which you need to replace on the gobo carousel.
12. Place head covers back on the fixture. Replace the bottom cover before applying power.

4.4 Rigging the fixture

A structure intended for installation of the fixture(s) must safely hold weight of the fixture(s) placed on it. The structure has to be certificated to the purpose.

The fixture (fixtures) must be installed in accordance with national and local electrical and construction codes and regulations.

For overhead installation, the fixture must be always secured with a safety wire that can bear at least 10 times the weight of the fixture

When rigging, de-rigging or servicing the fixture staying in the area below the installation place, on bridges, under high working places and other endangered areas is forbidden.

The operator has to make sure that safety relating and machine technical installations are approved by an expert before taking into operation for the first time and after changes before taking into operation another time.

The operator has to make sure that safety relating and machine technical installations are approved by a skilled person once a year.

Allow the fixture to cool for ten minutes before handling.

The projector should be installed outside areas where persons may walk by or be seated.

IMPORTANT! OVERHEAD RIGGING REQUIRES EXTENSIVE EXPERIENCE, including calculating working load limits, installation material being used, and periodic safety inspection of all installation material and the projector. If you lack these qualifications, do not attempt the installation yourself, but use a help of professional companies.

CAUTION: Fixtures may cause severe injuries when crashing down! If you have doubts concerning the safety of a possible installation, do not install the fixture!

The fixture has to be installed out of the reach of public.

The fixture must never be fixed swinging freely in the room.

***Danger of fire !
When installing the device, make sure there is no highly inflammable material (decoration articles, etc.) in a distance of min. 1 m.***

***CAUTION!
Use 2 appropriate clamps to rig the fixture on the truss.
Follow the instructions mentioned at the bottom of the base.
Make sure that the device is fixed properly! Ensure that the structure (truss) to which you are attaching the fixtures is secure.***

The fixture can be placed directly on the stage floor or rigged in any orientation on a truss without altering its operation characteristics .

For securing the fixture to the truss, install a safety wire which can hold at least 10 times the weight of the fixture. Use only the safety wire with a snap hook with screw lock gate.

Truss installation

1. Bolt clamps (1) to the brackets Omega CL (2) with M12 bolts and lock nuts through the hole in the bracket Omega CL.
2. Fasten the brackets Omega CL on the bottom of the base by means of the quick-lock fasteners (3) and tighten them fully clockwise.
3. Fasten the T.5 on the truss (6) by means of two clamps (1).
4. Pull the safety wire (4) through the handle (7) and the truss (6) as shown on the picture below in a suitable position so that the maximum fall of the fixture will be 20 cm. Fasten a snap hook in the attachment point (5). Use only the safety wire with a snap hooks with screw lock gates.

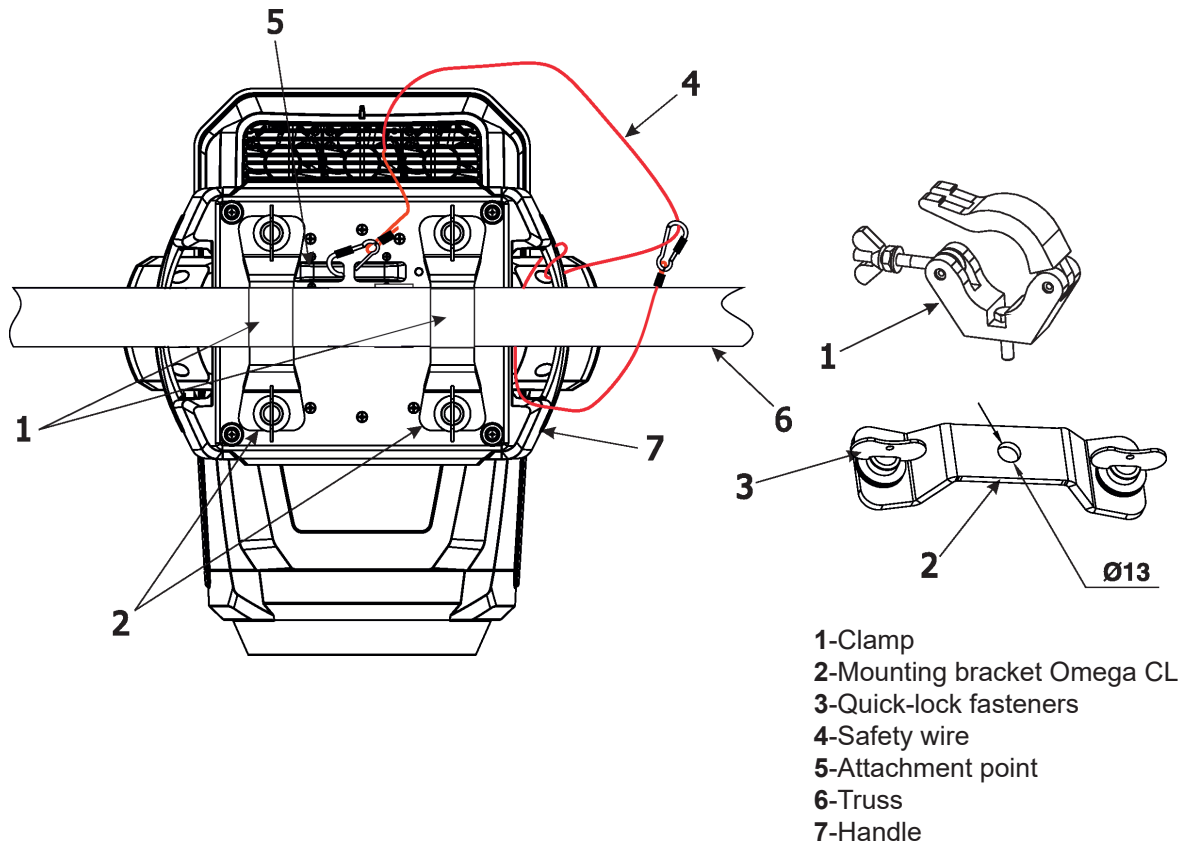

***When installing fixtures side-by-side,
avoid illuminating one fixture with another!***

DANGER TO LIFE!
***Before taking into operation for the first time, the installation has to be approved by
an expert!***

***In order to protect the internal parts of the head from the sun, the function
PARKING POSITION must be switched ON before switching the fixture off.***

The PARKING POSITION function is located on the Power/Special functions channel (120-129 DMX). If the function is on, the fixture will automatically detect via G-sensor whether the fixture is on the floor or hangs on the truss or is mounted sideways on the truss and moves the pan and tilt to the position (including movement of zoom to the front part of the head) in which the head will always face down. Owing this position of the fixture head, there is not chance to burn internal parts of the head by the sun light.

4.5 DMX-512 connection

The fixture is equipped with 5-pin XLR sockets for DMX input and output. The sockets are wired in parallel. Only use a shielded twisted-pair cable designed for RS-485 and 5-pin XLR plugs and connectors in order to connect the controller with the fixture or one fixture with another.

DMX output

XLR socket (female)



- 1 - Shield
- 2 - Signal (-)
- 3 - Signal (+)
- 4 - Not connected
- 5 - Not connected

DMX input

XLR socket (male)



- 1 - Shield
- 2 - Signal (-)
- 3 - Signal (+)
- 4 - Not connected
- 5 - Not connected

If you are using the standard DMX controllers, you can connect the DMX output of the controller directly with the DMX input of the first fixture in the DMX chain. If you wish to connect DMX controllers with other XLR outputs, you need to use adapter cables.

Building a serial DMX chain.

Connect the DMX output of the first fixture in the DMX chain with the DMX input of the next fixture. Always connect one output with the input of the next fixture until all fixtures are connected. Up to 32 fixtures can be connected.

Caution: At the last fixture, the DMX cable has to be terminated with a terminator. Solder a 120 Ω resistor between Signal (-) and Signal (+) into a 5-pin XLR plug and plug it in the DMX output of the last fixture.

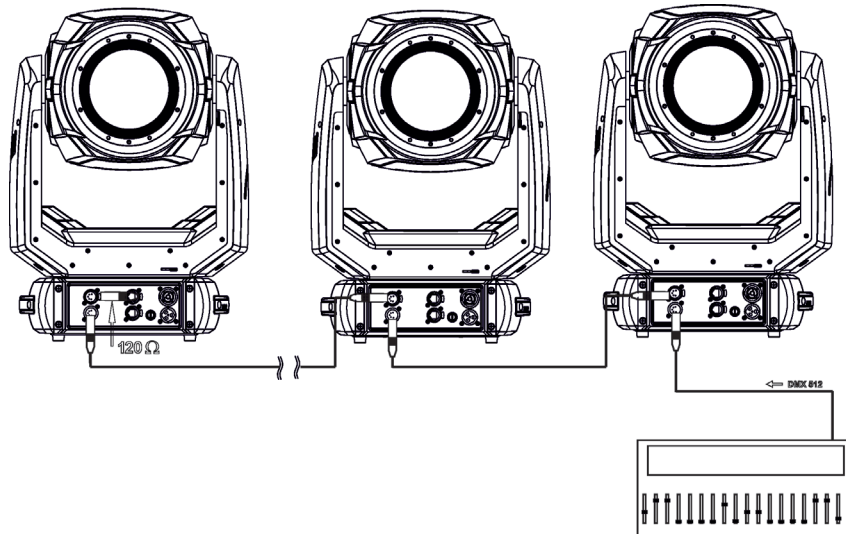

4.6 Ethernet connection

The fixtures on a data link are connected to the Ethernet with appropriate communication protocol (e.g. Art-Net). The control software running on your PC (or light console) has to support Art-Net protocol. Art-Net communication protocol is a 10 Base T Ethernet protocol based on the TCP/IP. Its purpose is to allow transfer of large amounts of DMX 512 data over a wide area using standard network technology.

IP address is the Internet protocol address. The IP uniquely identifies any node (fixture) on a network.
The Universe is a single DMX 512 frame of 512 channels.

The Robin T.5 Profile is equipped with 8-pin RJ-45 socket for Ethernet input. Use a network cable category 5 (with four “twisted” wire pairs) and standard RJ-45 plugs in order to connect the fixture to the network.

RJ-45 socket (front view):

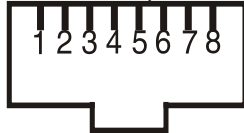

- | | |
|------------------|------------------|
| 1- TD+ | 5- Not connected |
| 2- TD- | 6- RX- |
| 3- RX+ | 7- Not connected |
| 4- Not connected | 8- Not connected |

RJ-45 plug (front view):

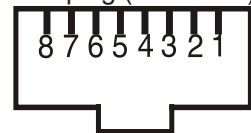

Patch cables that connect fixtures to the hubs or LAN sockets are wired 1:1, that is, pins with the same numbers are connected together:



If only the fixture and the computer are to be interconnected, no hubs or other active components are needed. A cross-cable has to be used:



If the fixture is connected with active Ethernet socket (e.g. switch) the network icon  will appear at the bottom right corner of the screen:



Ethernet operation

Connect the Ethernet inputs of all fixtures with the Ethernet network.

Option “Artnet” (gMal or gMA2 or sACN) has to be selected from “Ethernet Mode” menu at each fixture. Set IP address (002.xxx.xxx.xxx / 010.xxx.xxx.xxx) and the Universe at each fixture.

Example:

- | | | | |
|---|--|--|---|
| (DMX address=148)
IP address=002.168.002.004
Universe=1 | (DMX address=99)
IP address=002.168.002.003
Universe=1 | (DMX address=50)
IP address=002.168.002.002
Universe=1 | (DMX address=1)
IP address=002.168.002.001
Universe=1 |
|---|--|--|---|

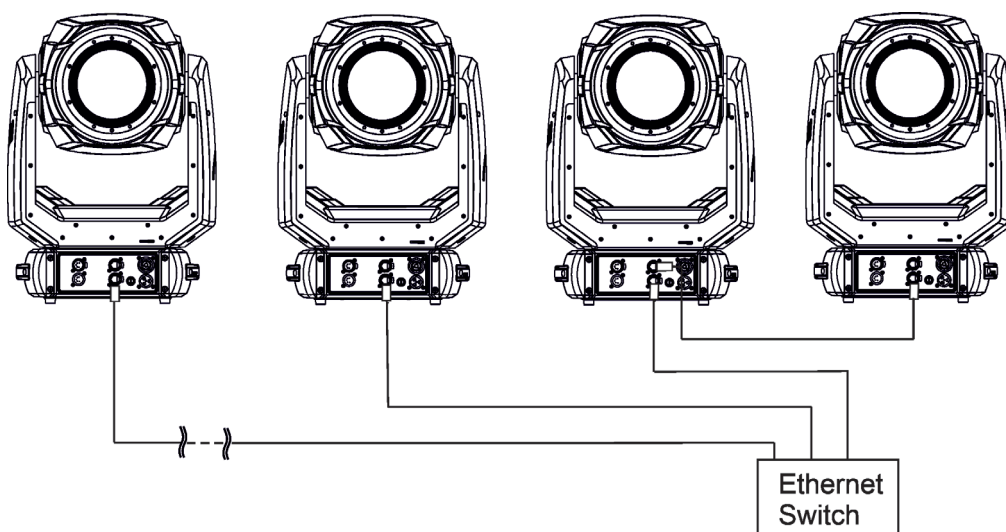

An advised PC setting: IP address: 002.xxx.xxx.xxx / 010.xxx.xxx.xxx (Different from fixture IP addresses)
 NET mask: 255.0.0.0

The EP version of the fixture (Ethernet in/out) is equipped with Ethernet Pass Through Switch which sustains Ethernet integrity, when the fixture has no power, it automatically maintains network connectivity. If you use the Ethernet IN-OUT way for the Ethernet connection, max. 8 fixtures can be connected in the IN-OUT line.

Ethernet / DMX operation

Option "Artnet" (gMal or gMA2 or sACN) has to be selected from "Ethernet Mode" menu at first fixture.
 Option "Ethernet To DMX" has to be selected from the "Ethernet Mode" menu at the first fixture (connected to the Ethernet) in the fixture chain, next fixtures have standard DMX setting.
 Connect the Ethernet input of the first fixture in the data chain with the network. Connect the DMX output of this fixture with the input of the next fixture until all fixtures are connected to the DMX chain.

Caution: At the last fixture, the DMX chain has to be terminated with a terminator. Solder a 120 Ω resistor between Signal (-) and Signal (+) into a XLR-plug and connect it in the DMX-output of the last fixture.

Example:

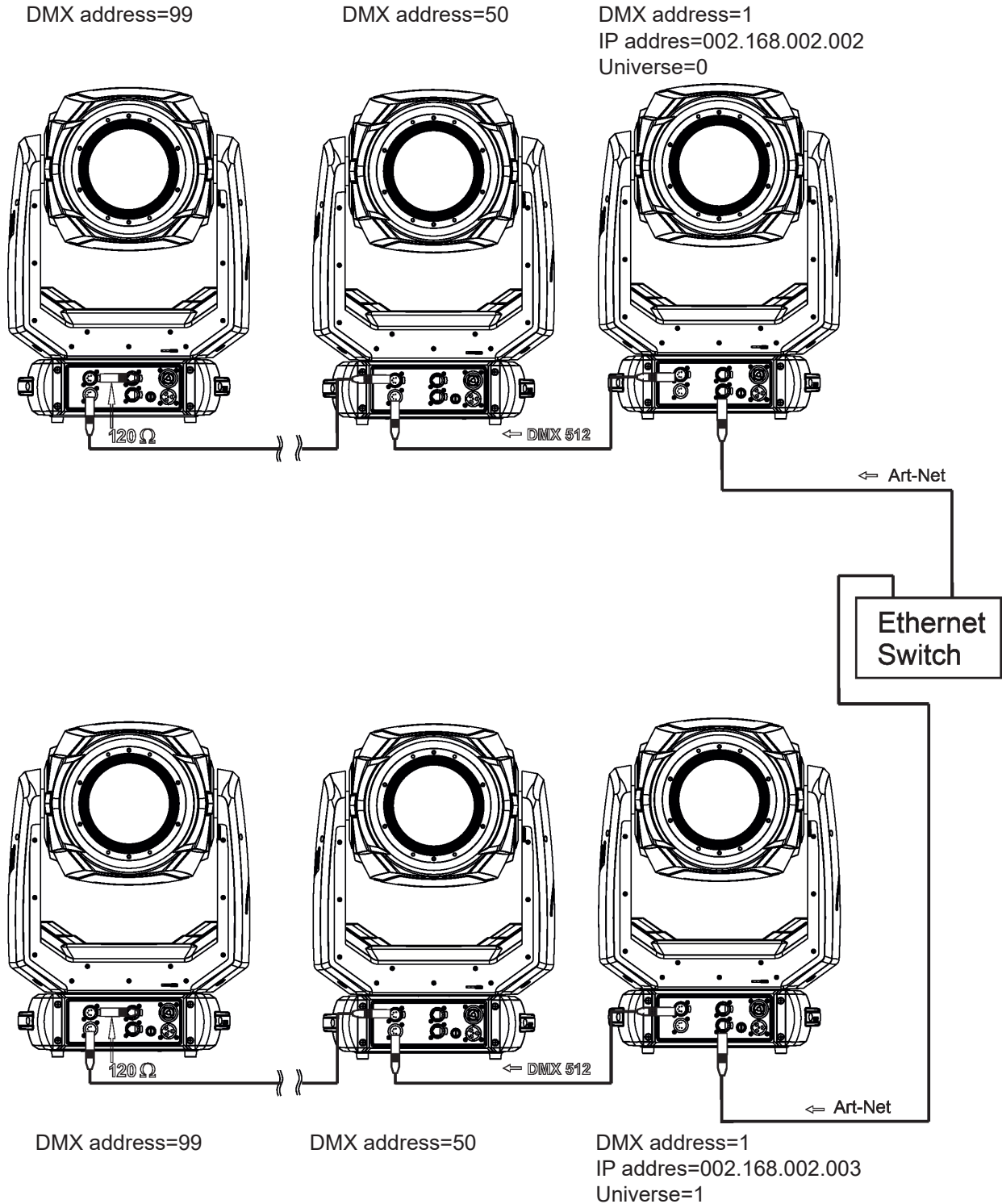

4.7 Wireless DMX operation

The wireless DMX version of the fixture is equipped with the wireless DMX/RDM module which has full support for wireless communication protocols at entertainment market. The module is based on well known Lumen-Radio RF technology, with implemented wire interface for connection with Robe products. RF output for MCX interface antenna as standard output.

The item " Wireless " from the menu "DMX Input" allows you to activate receiving of wireless DMX (Personality--> DMX Input -->Wireless.). First two options from the "DMX Input" menu are stated in DMX chart as well (channel Power/Special functions , range of 10-19 DMX). If DMX input option is changed by DMX command, the change is permanently written into fixture's memory.

DMX range of 10-19 switching fixture to the wired/wireless operation is active only during first 10 seconds after switching the fixture on.

After switching the fixture on, the fixture checks both modes of receiving DMX in the following order:

1. For the first five seconds, the fixture receives DMX signal from the wired input. If the Power/Special functions channel is set at some DMX input option, the fixture will receive DMX value according to this option. If DMX input option is set to the wired input , this option is saved and checking procedure is finished. If DMX input option is not set, the fixture continues next 5 seconds in scanning wireless DMX signal-see point 2.

2. For the next 5 seconds the fixture receives wireless DMX signal and again detects if the Power/Special functions channel is set at some DMX input option, if not, the fixture will take option which is set in the fixture menu "DMX Input".

To link the fixture with DMX transmitter.

The fixture can be only linked with the transmitter by running the link procedure at DMX transmitter . After linking , the level of DMX signal (0-100 %) is displayed in the menu item "Wireless State" (Information -->Wireless State).

To unlink the fixture from DMX transmitter.

The fixture can be unlinked from transmitter via the menu item " Unlink Wireless Adapter" (Information--> Wireless State --> Unlink Wireless Adapter).

Example of connection:

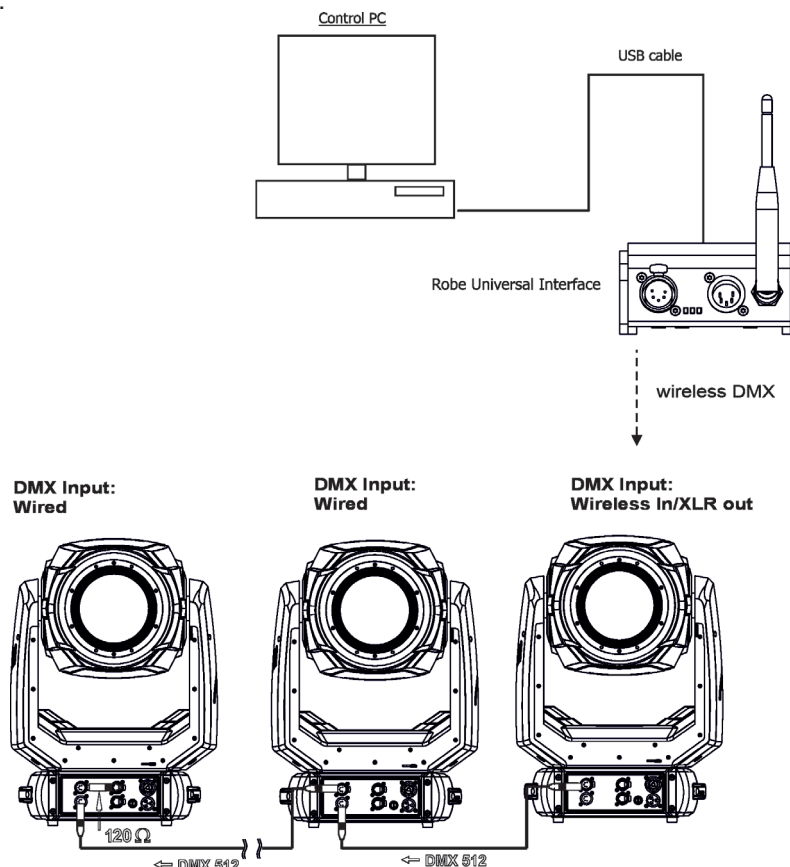

5. Remotely controllable functions

5.1 Colour influencing functions

Factory setting of menu functions (channels) which influence behaviour of colour channels is the following:

Function	Factory setting	Function	Factory setting
DMX mode	1	Uniformity	Off
Colour calibration mode	On	Colour mix control	0 DMX
Colour mixing mode	CMY	CTC	110 DMX (5600K)
Dimmer curve	Square law	CRI Selection	Standard (80)
Tungsten effect simulation	Off	Green correction	Uncorrected
Chromatic white	Off	Shutter/Strobe	Open (32 DMX)
Light output stability	Off	Dimmer	Closed (0 DMX)

Colour calibration mode (menu tab "Personality")

The function switches on/off an internal control of colours. For a standard operation of the fixture the option should be switched on. Option off has to be set during colour calibration of the fixture (in this mode some functions e.g. Tungsten effect, Virtual colour wheel are disabled).

Colour mixing system (menu tab "Personality", DMX channel "Colour functions")

This item allows selection between RGB and CMY mode. In both 3-colour controlling modes (Mode 1, Mode 2) all internal 5 colours are always utilized where possible.

Dimmer curve (menu tab "Personality", DMX channel "Colour functions")

The fixture allows you to select a linear dimmer curve or a square law curve.

Tungsten effect simulation (menu tab "Personality", DMX channel "Colour functions")

The function simulates behaviour of a halogen lamp during dimming at calibrated white colours 2700K - 4200K. You can select from various lamp wattage simulation: 750W, 1000W, 1200W, 2000W, 2500W. If the function Chromatic white is on, the Tungsten effect will influence also mixed colours.

Saving user colours (DMX channel "Colour functions")

To save user colours:

1. Set the function White Point to off (Channel Colour Mix Control, range 70-79 DMX).
1. Mix desired colour on colour channels.
2. Stay in desired position of user colours (216-235 DMX) on the Virtual colour wheel for 1 sec.
3. Leave the range of user colours (216-235 DMX) on the Virtual colour wheel.
4. Repeat steps 2-4 for next user colour.
5. To permanently save user colours, stay for 3 sec. at DMX range of 110-114 on the channel Colour functions. After that the colour system will be reset (this action can last about 2 minutes). Previous user colours will be overwritten.

Chromatic white (menu tab "Personality", DMX channel "Colour functions")

If the function is on, the CTC channel influences calibrated white colours and mixed colours (also colours on Virtual colour wheel).

If the function is off, the CTC channel influences calibrated whites only.

Light output stability (menu tab "Personality", DMX channel "Colour functions")

If the function is on, the light output from the fixture is immediately reduced to a value corresponding to a thermal drop of the light intensity from the LED engine (the thermal drop of light intensity - decreasing of the light intensity on circa 90 % of starting level after first 5 minutes, then is the thermal drop of light intensity inconsiderable).

Output Uniformity (menu tab "Personality", DMX channel "Colour functions")

If the function is on, the light intensity from the fixture is corrected in order to get approximately the same light intensity as from another fixture which has also the function on. Thanks to the function, light outputs from more fixtures will have approximately the same light intensity.

Colour Mix control (DMX channel "Colour Mix control")

The Colour Mix control channel defines relation between colour channels (Cyan, Magenta, Yellow, Red, Green, Blue, Amber, Light Green and CTC) and the colours on the virtual colour wheel:

DMX value	Function
0 - 9	Virtual colour wheel has priority over colour channels (default setting)
10-19	Maximum mode (highest values have priority)
20-29	Minimum mode (lowest values have priority)
30-39	Multiply mode (multiply virtual colour wheel and colour channels)
40-49	Addition mode (virtual colour wheel + colour channels)
50-59	Subtraction mode (virtual colour wheel – colour channels)
60-69	Inverted Subtraction mode (virtual colour wheel – colour channels)
70-79	White Point Off (CTC+green correction+virtual col. wheel deactivated)
80-128	Reserved
129	Crossfade Virtual colour wheel only
130-254	Crossfade between virtual colour wheel and colour channels
255	Crossfade colour channels only

CTC (DMX channel " Colour temperature correction")

The CTC channel allows you to change a colour temperature of calibrated white colours in range of 8000K-2700K and also can influence mixed colours including colours on the Virtual colour wheel.

For correct function of the CTC channel on calibrated white colours, the following conditions have to be kept:

1. The Colour calibration mode has to be set on.

If the Chromatic white is set off, the CTC channel influences white colours only.

If the Chromatic white is set on, the CTC channel influences white colours and mixed colours including colours on the Virtual colour wheel.

2. The following channels have to be set at:

Virtual colour wheel at 0 DMX

Green correction at 128 DMX

Colour mix control channel at 0 DMX

3. Colour channels have to be set depending on the colour mixing mode and the DMX mode.

CMY colour mixing mode.

DMX mode 1:

Channels Cyan/Red, Magenta/Green and Yellow/Blue (both 8-bit and 16-bit channels for each colour) have to be set at 0 DMX or at the same DMX value (except 255 DMX).

DMX mode 2:

Channels Cyan/Red, Magenta/Green and Yellow/Blue have to be set at 0 DMX or at the same DMX value (except 255 DMX) .

DMX mode 3:

The mode is not intended for CMY colour mixing mode.

RGB(A,LG) colour mixing mode

DMX mode 1:

Channels Cyan/Red, Magenta/Green and Yellow/Blue (both 8-bit and 16-bit channels for each colour) have to be set at 255 DMX or at the same DMX value (except 0 DMX).

DMX mode 2:

Channels Cyan/Red, Magenta/Green and Yellow/Blue have to be set at 255 DMX or at the same DMX value (except 0 DMX).

DMX mode 3:

Channels Red, Green, Blue, Amber, Light Green (both 8-bit and 16-bit channels for each colour) have to be set at 255 DMX or at the same DMX value (except 0 DMX).

4. Shutter and dimmer have to be open.

CRI correction (DMX channel " CRI Selection")

The channel allows you to set CRI from Standard (80) to High (90+). Default setting is to 0 DMX (Standard CRI).

Green correction (DMX channel "Green correction ")

The channel allows you a fine correction of colours (whites, mixed colours, colours on the Virtual colour wheel).
E.g. white colour from red to green tint.

Virtual colour wheel (DMX channel " Virtual colour wheel")

The virtual colour contains 67 preset colours, 10 user colours and 70 multicolours. The multicolours are intended to use with the following effects only:

- Effect wheel (DMX range: 20-255)
- Effect wheel animation (DMX range: 8-27)
- Rotating gobo wheel (DMX range: 4-199; 202-255)
- Prism (DMX range: 20-255)

At least one of the effects stated above has to be inserted into the light beam.

There are several examples of using multicolours with prism/gobo combination:

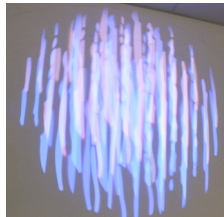
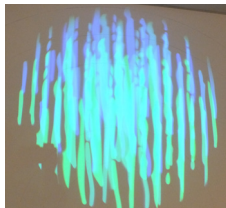

Dimmer/Shutter (DMX channels " Shutter/Strobe" and "Dimmer Intensity")

Smooth 0 - 100 % dimming is provided by the electronic control unit of the light source. The control of the light source also allows strobe effects with variable speed.

5.2 Effect functions

Effect wheel

The wheel rotates in both directions with variable speed which creates wide spectrum of graphic effects.

Gobo wheel

The fixture includes rotating gobo wheel with 7 glass gobos rotating in both directions, indexable, replaceable "SLOT&LOCK" system.

Prism

The 6-facet prism rotates in both directions at different speeds, 16 prism/gobo macros are available.

Frost

Two frost filters (light 1° and medium 5°) provide variable frost for fine frosting. The medium frost is replaceable.

Iris

Motorized adjustable iris, wide range of variable pulse effects.

Zoom

Motorized zoom unit enables zoom between 5° - 55°.

Focus

Motorized focus allows to focus beam from approx. 2 meters to infinity.

Framing system

Framing system consists of four framing shutters. There is individual control of each shutter blade position and angle, together with rotation of the complete framing module. As well as providing a sharp precise or soft frame for the projected image.

Framing system orientation:

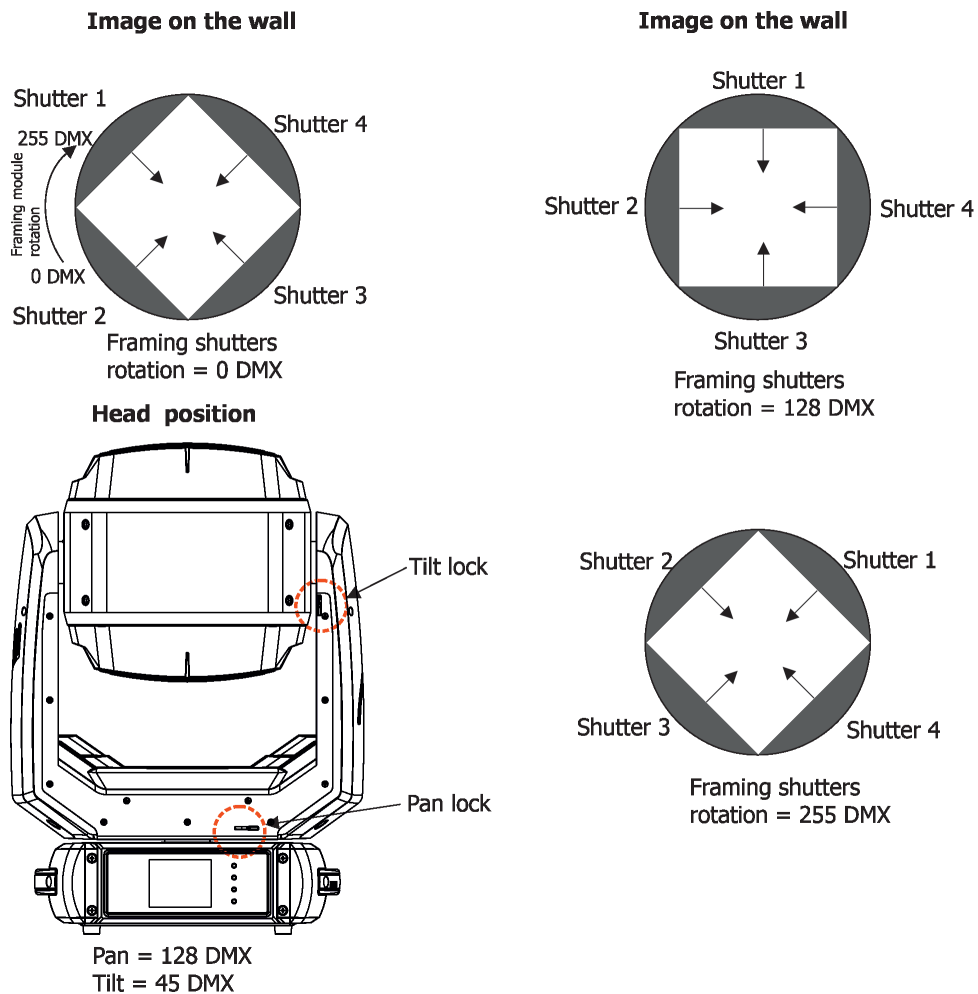

Pan/Tilt

Fast pan/tilt movement due to built-in electronic motion stabilizer (EMS). The electronic motion stabilizer ensures precise position of the fixture's head during its movement and reduces its swinging when the truss shakes. Pan /Tilt movement range: 0-540°/0-265°.

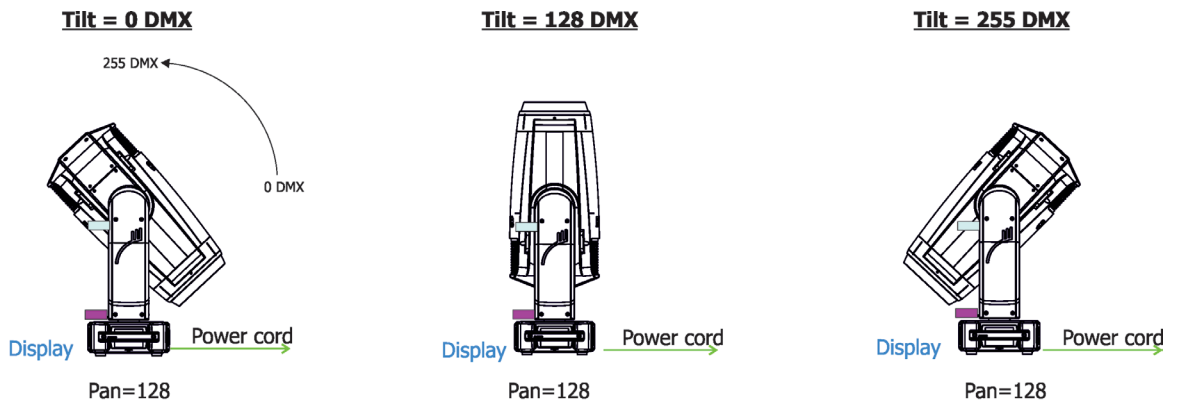

Tilt movement range: 265° Pan movement range: 540°

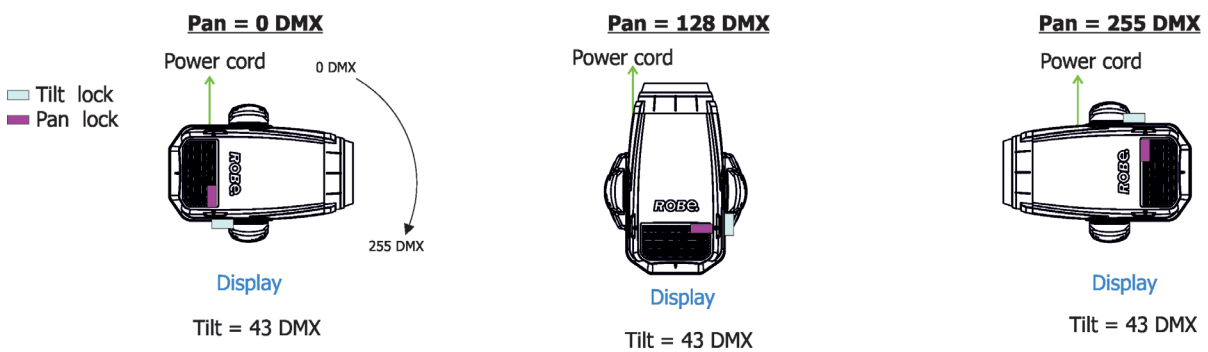



6. Control menu map

Default settings=**Bold print**

Tab	Level 1	Level 2	Level 3	Level 4	Level 5	Level 6
Addressing	DMX Address		001-512			
	DMX Presets	Mode 1				
		Mode 2				
		Mode 3				
		View Selected Preset				
		Ethernet Settings	Ethernet Mode	Disable		
			ArtNet			
			gMA1			
			gMA2			
			sACN			
		Ethernet To DMX	Off , On			
		IP Address/Net Mask	Default IP Address			
			Custom IP Address			
			Net Mask			
		ArtNet Universe	0-255			
		MANet settings	MANet/II Universe	01-256		
			MANet Session ID	01-32		
		sACN Settings	sACN Universe	00001-32000		
Information	Fixture Times	Power On Time	Total Hours			
			Resetable Hours			
		LEDs On Time	Total Hours			
			Resetable Hours			
		Air Filters	Elapsed Time			
			Alert Period	10-300		
	Fixture Temperatures	LEDs Temperatures	Cur.	R/A, GY, B		
			Max.			
			Max.Res.			
		LEDs Brd. 1 Temperature	Current			
			Maximum NonRes.			
			Maximum Res.			
		LEDs Brd. 2 Temperature	Current			
			Maximum NonRes.			
			Maximum Res.			
		Base Temperature	Current			
			Maximum NonRes.			
			Maximum Res.			
	DMX Values	Pan				
		:				
		Dimmer Fine				
	Wireless State	Signal Quality				
		Unlink Wireless Adapter				
	Power Channel state					
	Colour functions state					
	Software Versions	Display System				
		Module M				
		Module L1				
		Module L2				
		Module L3				
		Module O				
		Module F-A				

Tab	Level 1	Level 2	Level 3	Level 4	Level 5	Level 6
		Module F-B				
		Module G				
	Product IDs	Mac Address				
		RDM UID				
		RDM Label				
	LED Module Info	First Module Assembly				
		Asseby History				
	LED Modules History					
	View Logs	Fixture Errors				
		Fixture States	Power On			
			Power Off			
		Fixture Position				
		Fixture Temperatures	LEDs B.1 Temperature			
			LEDs B.2 Temperature			
			Base Temperatures			
Personality	DMX Presets	Mode 1				
		Mode 2				
		Mode 3				
		View Selected Preset				
	DMX Input	Wired				
		Wireless				
		Wireless In/XLR Out				
	Pan/Tilt Settings	Pan Reverse	Off, On			
		Tilt Reverse	Off, On			
		Pan/Tilt Feedback	Off, On			
		Pan/Tilt mode	Time			
			Speed			
	Pan/Tilt EMS	On				
		Off				
	Follow Spot Mode	off				
		Soft				
		Medium				
		Hard				
	Pan/Tilt Limitation	Pan Min. Value	0-255			
		Pan Max. Value	0-255			
		Tilt Min. Value	0-255			
		Tilt Max. Value	0-255			
	Microphone Sensitivity	1-10-20				
	Blackout Settings	Blackout During M.C.	Off, On			
		Blackout while:	Pan/Tilt moving	Off, On		
			Gobo Wheel Moving	Off, On		
	Quiet Mode	Off				
		Quiet	0-100%			
	Colour Calibration Mode	On, Off				
	Colour Mixing Mode	CMY, RGB				
	Chromatic White	Off, On				
	Light Output Stability	On, Off				
	Output Uniformity	On, Off				
	Frequency Setup	300 Hz				
		600Hz				
		1200Hz				
		2400Hz				
		High				
		Frequency Adjust				

Tab	Level 1	Level 2	Level 3	Level 4	Level 5	Level 6
	User Colours	View User Colours	View User Colour 1.. View User Colour 10			
		Distribute User Colours				
	Thungsten Eff. Sim.	Off				
		750W				
		1000W				
		1200W				
		2000W				
		25000W				
	Init Effect Positions	Pan	0-255			
		:				
		Dimmer Fine	0-255			
	Reset Effect Positions					
	Screen Settings	Display Intensity	1-10			
		Screen Saver Delay	Off-10min.			
		Touchscreen Lock	Off-10min.			
		Recalibrate Touchscreen				
		Display Orientation	Normal			
			Inverted			
			Auto			
	Temperature Unit	°C, °F				
	Fan Settings	Fan Mode	Auto			
			High			
			Quiet			
			Fan Noise Level			
		Quiet-Blackout Fan Off	Off			
			On			
	Dimmer Curve	Linear				
		Square law				
		Super Square law				
	Gobo Indexing	Max. Speed & ShortCut				
		Follow Speed & Direction				
		Max. Speed & ShortCut				
	Date & Time Settings					
	Focus Tracking	Off				
		On				
	Default Settings					
	Password Protection	Off, On				
	Reset Web Password					
Manual Control	Reset Functions	Total System Reset				
		Pan/Tilt reset				
		Gobo/Eff. Wh. Reset				
		Optics/Prism/Frost Res.				
		Iris/framing Sh. Reset				
	Manual Effect Control	Pan	0-255			
		:				
		Dimmer Fine	0-255			
Stand -Alone	Cue Playback	Preset Playback				
		Play Cue				
		Edit Cue				
	Test Sequences	Dynamic Mode				
		Static Mode	Pan	0-255		
			Tilt	0-255		
			Zoom	0-255		
			Focus	0-255		

Tab	Level 1	Level 2	Level 3	Level 4	Level 5	Level 6
	MusicTrigger	Off, On				
	Preset Playback	None				
		Cue				
		Test				
		Prog. 1				
		Prog. 2				
	Play Program	Play Program 1				
		Play Program 2				
		Play Program 3				
	Edit Program	Edit Program 1	Start Step	1-68		
		Edit Program 2	End Step	1-68		
			Edit Program Steps	Step 1	Pan	0-255
				:	:	
				:	Dimmer Fine	0-255
				:	Step Time	0-25,5 sec.
				Step 68	Pan	0-255
					:	
					Step Time	0-25,5 sec.
Service	Adjust DMX Values	Pan	0-255			
		:				
		Dimmer Fine	0-255			
	Calibrations	Calibrate Effects	Pan	0-255		
			Tilt	0-255		
			Effect Wheel	0-255		
			Rot. Gobo Wheel	0-255		
			R. Gobo Index 1	0-255		
			:			
			R. Gobo Index 7	0-255		
			Prism 1	0-255		
			Prism 2	0-255		
			Zoom	0-255		
			Focus	0-255		
			Iris	0-255		
			Frost 1/1	0-255		
			Frost 1/2	0-255		
			Frost 2/1	0-255		
			Frost 2/2	0-255		
			Fr. Shutters rot.	0-255		
			Fr. Shutter 1 Move	0-255		
			Fr. Shutter 1 Swiv	0-255		
			Fr. Shutter 2 Move	0-255		
			Fr. Shutter 2 Swiv	0-255		
			Fr. Shutter 3 Move	0-255		
			Fr. Shutter 3 Swiv	0-255		
			Fr. Shutter 4 Move	0-255		
			Fr. Shutter 4 Swiv	0-255		
		Calibrate Fr. Hysteresis	Framing Lamella 1	0-8		
			Framing Lamella 2	0-8		
			Framing Lamella 3	0-8		
			Framing Lamella 4	0-8		
		Calibrate colours	Red Calibration	X, Y, Int, Temp		
			Green Calibration	X, Y, Int, Temp		
			Blue Calibration	X, Y, Int, Temp		
			Amber Calibration	X, Y, Int., Temp		
			Lime Calibration	X, Y, Int., Temp		

Tab	Level 1	Level 2	Level 3	Level 4	Level 5	Level 6
		Green Corrections	2700K CRI 70			
			3200 K CRI 70			
			4200K CRI 70			
			5600K CRI 70			
			8000K CRI 70			
			2700K CRI 90			
			3200K CRI 90			
			4200K CRI 90			
			5600K CRI 90			
			8000K CRI 90			
		Calibrate Pan/Tilt EMS				
		Calibrate Pan/Tilt Reset				
		Load Default Calibrations				
		LEDs Current Calibration				
	Rotating Gobos Change	Gobo Carousel 1	G1-Mg, G2...G7			
			Gobo Offset			
	LEDs HW Versions	LEDs R/A HW Version				
		LEDs G/Y HW Version				
		LED B HW Version				
	LEDs Measure					
	Update Software					

7. Control menu

The Robin T.5 Profile is equipped with the QVGA Robe touch screen with battery backup which allows you to set the fixture's behaviour according to your needs, obtain information on its operation, control all range of effects and program it in stand-alone mode.

The fixture's menu can be controlled either by the control buttons or directly by touching the icon.

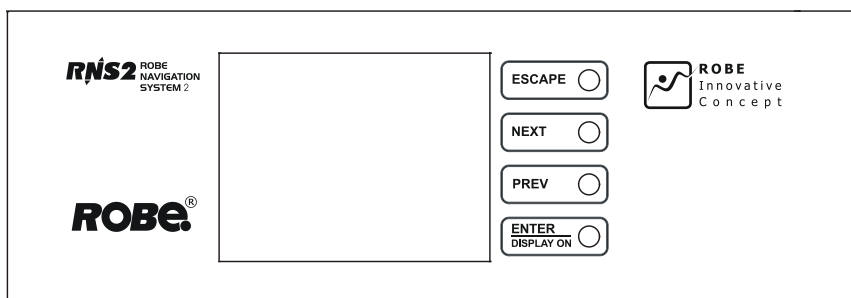

Control buttons on the front panel:

[ESCAPE] button used to leave the menu without saving changes.

[NEXT] , [PREV] buttons for moving between menu items and symbols, adjusting values.

[ENTER/Display On] button used to enter the selected menu (menu item) and to confirm adjusted value.

If the fixture is disconnected from mains, the button switches the touch screen on.

Icons used in the touch screen menu:



- [back arrow] used to move back to the previous screen (menu).



- [up arrow] used to move up on the previous page.



- [down arrow] used to move down on the next page.



- [confirm] used to save adjusted values, to leave menu or to perform desired action.



- [cancel] used to leave menu item without saving changes.



- [confirm+copy] used to save adjusted values and copy them to the next prog. step.



- [warning icon] used to indicate some error which has occurred in the fixture.



- [Ethernet] used to indicate Ethernet connected.



- [menu rotation] used to rotate menu 180 degrees from current orientation.



- [slider control] used to recall slider system for setting desired value.



- [keyboard control] used to recall keyboard system for setting desired value.



- [air filters cleaning] used to signal that cleaning period of the air filters elapsed.

The menu page displays icons for each function that you can perform from the touch screen.

After switching the fixture on, the touch screen shows the screen with the ROBE logo:

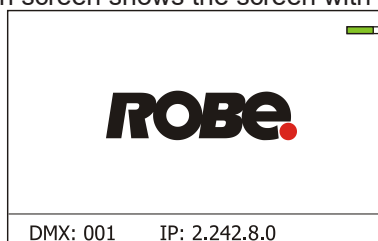

Touch any part of the screen or press the [ENTER/Display On] button to display the initial screen with the current stored DMX address:

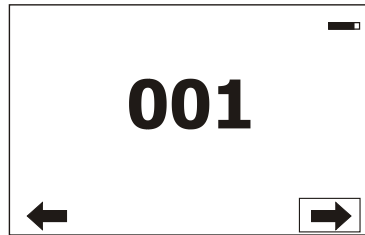

Note: The green icon at the top right corner of the screen indicates the level of the display battery charging. If the whole icon is green, the battery is fully charged while the red icon indicates exhausted battery. The battery charges during fixture operation, its charging lasts cca 6 hours.

We recommend that the fixture should be in operation at least 7 hours per week to keep the battery fully charged. If you switch the fixture on and this screen will not appear till 1 minute, switch the fixture off and on again. If the screen lights, the battery is exhausted. In case the screen still does not light, the battery is faulty.

This is also indicated by an error message "Faulty battery" and if such an error message appears the battery should be replaced immediately. The lifetime of the battery is highly dependent on ambient temperature (and consequently on base temperature). If the maximum ambient temperatures (as recorded and displayed in menu: Information -> Fixture Temperatures -> Ambient Temperature -> Maximum NonRes.) are kept within the specified limits, the battery should last for at least two years. Should the ambient temperatures exceed the specified maximum temperature, the lifetime of the batteries could be considerably shortened even up to just one year or less and also result in physical damage (battery leakage) or unreliable fixture functions.

Damage caused by batteries failed due to exceeded maximum ambient temperature cannot be claimed under warranty terms.

Touch the green arrow at the bottom right corner of the screen or press the [ENTER/Display On] button to enter the "Address" menu.

Each item (such as a Tab, menu item, text box, icon) may be selected from a screen by simply touching the item in the list or by pressing the [NEXT] or [PREV] buttons to scroll through list items. With each press, the next item is highlighted. Press [ENTER/Display On] to select the highlighted item.

Before first fixture operation, set current date and time in the menu "Date &Time Settings" (menu path: Personality--> Date &Time Settings).

7.1 Tab "Address"



DMX Address - Select the menu to set the DMX start address.

linking DMX address means that the fixture is either not receiving DMX data or that the set DMX address is higher than allowed, exceeding the DMX footprint of the set DMX mode.

DMX Preset - Use the menu to select desired channel mode.

DMX Preset - Use the menu to select desired channel mode.

Mode 1 - 49 control channels

Mode 2 - 33 control channels

Mode 3 - 53 control channels

View Selected Preset - Use the menu to display channels included in the selected mode.

Ethernet Settings - The menu allows all needed settings for the Ethernet operation

Ethernet Mode

Disable - The option disables Ethernet operation.

Artnet - Fixture receives Artnet protocol

gMAI - Fixture receives MANet 1 protocol

gMA2 - Fixture receives MANet 2 protocol

sACN - Fixture receives sACN protocol

Ethernet To DMX - Fixture receives protocol from the Ethernet input and sends DMX data to its DMX output (fixture works as an "Ethernet/DMX converter", next fixture can be connected to its DMX output and you can build a standard DMX chain by connecting another fixtures. Only one fixture has to be connected to the Ethernet.

IP Address/Net Mask - Select this menu to set IP address. IP address is the Internet protocol address. The IP uniquely identifies any node (fixture) on a network.

There cannot be 2 fixtures with the same IP address on the network!

Default IP Address -Preset IP address, you can set up only first byte of IP address (2 or 10) e.g. **002.019.052.086**.

Custom IP Address - The option enables to set up all bytes of IP address.

Net Mask - The option enables to set up all bytes of Net Mask.

ArtNet Universe - Use this item to set a Universe (0-255). The Universe is a single DMX 512 frame of 512 channels.

MANet Settings - Use this menu to set parameters for MANet operation.

MANet Universe I/II - The value of this item can be set in range 1-256.

MANet Session ID - The value of this item can be set in range 1-32.

sACN Settings - Use this menu to set parameters for sACN operation.

sACN Universe - The value of this item can be set in range 1-32000.

7.2 Tab "Information"



Fixture Times - The menu provides readouts of fixture and LED module operation hours.

Power On Time Hours - Select this menu to read the number of fixture operation hours.

Total Hours - The item shows the total number of the operation hours since the Robin T.5 Profile has been fabricated.

Resetable Hours - The item shows the number of the operation hours that the Robin T.5 Profile has been powered on since the counter was last reset.

In order to reset this counter to 0, touch the text box next to the item "Resetable Hours:"

LEDs On Time - Select this menu to read the number of LEDs operation hours.

In order to reset some counter to 0, touch the yellow text box next to desired colour.

Air Filters - Regular cleaning of the air filters is very important for the fixture's life and performance. Build-up of dust, dirt and fog fluid residues reduces the fixture's light output and cooling ability.

The two items of this menu help you to keep cleaning period of the air filters.

Alert period - Cleaning schedule for the fixture depends on the operating environment.

It is therefore impossible to specify accurate cleaning interval. This item allows you to change the cleaning interval of the air filters. This "alert" value is 300 hours and it is set as default. Inspect the fixture within its 300 hours of operation to see whether cleaning is necessary. If cleaning is required, clean all air filters and change the value in this menu on acceptable level. Min. level of alert period is 10 hours, max. is 300 hours.

Elapsed Time - The item allows you to read the time which remains to cleaning air filters.

The time period is set in the menu mentioned above.

Expired time period is signalled by a negative mark (-) at the time value and a warning icon on the display.

Clean the filters and reset this menu item (by touching the text box next to the item "Elapsed Time").

Fixture Temperatures - The menu is used to view temperatures of the fixture's inside.

LEDs temperatures - The menu shows temperature on the LED PCBs in the light source

(R=red LEDs, G=green LEDs, B=blue LEDs).

Cur. - A current temperature of the LED PCBs.

Max. - A maximum temperature of the LED PCBs since the fixture has been fabricated.

Max. Res. - A maximum temperature of the LED PCBs since the counter was last reset.

In order to reset some counter to 0, touch desired text box under item "Max.Res."

LEDs Brd.1 Temperature - The menu shows temperature on the LEDs control PCB (RB 3415-top side with coils) in the fixture head.

Current - A current temperature on the LEDs control PCB.

Maximum NonRes. - A maximum temperature on the LEDs control PCB since the fixture has been fabricated.

Maximum Res. - A maximum temperature on the LEDs control PCB since the counter was last reset.

In order to reset this counter to 0, touch the text box next to the item "Maximum Res."

LEDs Brd.2 Temperature - The menu shows temperature on the LEDs control PCB (RB 3415-bottom side) in the fixture head.

Current - A current temperature on the LEDs control PCB.

Maximum NonRes. - A maximum temperature on the LEDs control PCB since the fixture has been fabricated.

Maximum Res. - A maximum temperature on the LEDs control PCB since the counter was last reset.

In order to reset this counter to 0, touch the text box next to the item "Maximum Res."

Base Temperature - The menu shows temperature on the display PCB in the fixture base.

Current - A current temperature on the display PCB.

Maximum NonRes. - A maximum temperature on the display PCB since the fixture has been fabricated.

Maximum Res. - A maximum temperature on the display PCB since the counter was last reset.

In order to reset this counter to 0, touch the text box next to the item "Maximum Res."

DMX Values - The menu items allows you to read DMX values of each channel received by the fixture.

Wireless State - The menu serves for reading of the wireless operation status.

Unlink Wireless Adapter - The item serves for unlinking the fixture from a DMX transmitter.

If the wireless module is not installed in the fixture, message" Wireless Module Not Installed" will appear.

Power Channel State - Select this item to see current setting of the functions, which can be set by menu items in "Personality" as well as by DMX command at channel "Power/Special functions".

Colour Functions State - Select this item to see current setting of the colour functions, which can be set by menu items in "Personality" as well as by DMX command at channel "Colour functions".

Software Version - Select this item to read the software version of the fixture processors:

Display System - A display processor on the display board in the fixture base

Module M - Pan/Tilt processor

Module L1 - LEDs control processor 1

Module L2 - LEDs control processor 2

Module L3 - LEDs control processor 3

Module O - Focus/Zoom/Prism/ control processor

Module F-A -Framing shutters control processor

Module F-B - Framing shutters + Iris control processor

Module G - Rot. gobo/Effect wheel control processor

Product IDs - The menu is used to read the MAC Address ,RDM UID and RDM Label.

LED Module Info - Use this menu to read LEDs module information.

First Module Assembly - Use the item to read initial information about the LEDs module installed in the fixture. The fixture has to be connected to mains to read the values in the menu item.

Serial Number/ Device UID - a serial number of the LEDs module/RDM UID of the fixture.

Installation Date/Time - a date/time of the first installation of the LEDs module to the device.

Assembly History - Use the item to read a history of the LEDs modules installed in the fixture (their serial numbers and date/time of installation).

Up to 31 records can be saved in the menu item.

View Logs - Use this menu to read fixture's data which have been recorded during fixture operation. This collected data allows easier troubleshooting.

Fixture Errors - Use this menu to read fixture errors which have occurred during fixture operation.

Fixture States - In the menu are recorded fixture states as power on and power off.

Fixture Positions - In the menu are recorded installation positions of the fixture:

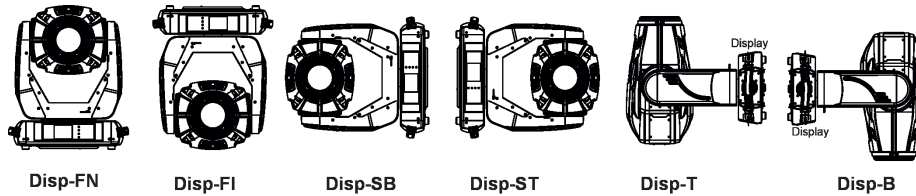

Fixture Temperatures - In the menu are recorded temperatures which have exceeded defined levels.

Note: The log buffer can contain max. 8000 records. If the buffer is full, old data will be overwritten.

7.3 Tab "Personality"



DMX Preset - Use the menu to select desired channel mode.

Mode 1 - 49 control channels

Mode 2 - 33 control channels

Mode 3 - 53 control channels

View Selected Preset - Use the menu to display channels included in the selected mode.

DMX Input - Use the menu to select mode of DMX signal receiving.

Wired - DMX signal is received by means of the standard DMX cable.

Wireless - DMX signal is received by means of the inbuilt wireless module.

Wireless In/XLR Out - the fixture receives wireless DMX and sends the signal to its wired DMX output.

The fixture behaves as "Wireless/Wired" adapter.

The options "Wired" and "Wireless" are also stated in DMX chart (channel Power/Special functions).

Note. If the wireless module is not installed in the fixture, the following message will appear:

DMX Input Set to Wired
Wireless Module Missing

If the fixture is not connected to mains, the message "Not Available In Off line Mode" will appear after entering the menu DMX Input. To enter this menu, the fixture has to be connected to mains.

Pan/Tilt Settings - Use the menu set behaviour of both pan and tilt movements.

Pan Reverse - The item allows to invert pan movement.

Tilt Reverse - The item allows to invert tilt movement.

Pan/Tilt Feedback - The item allows to return the mowing head to the required pan/tilt position after changing the position by an external force if this option is set on.

Note. Be careful, the Pan/Tilt Feedback should be permanent On, the option Off is not suitable for standard operation and the head of the fixture can be damaged!

Pan/Tilt mode - Use this menu to set the mode of the pan/tilt movement

Time mode - The pan and tilt will move with different speeds and they will come at the same time to the end point of their tracks (pan and tilt use their optimal speeds). Time of the pan/tilt movement (25.5 sec. max.) is set by the channel "Pan/Tilt speed, Pan/Tilt time".

Speed Mode - Both Pan and tilt will move with the same speed as adjusted at the channel "Pan/Tilt speed, Pan/Tilt time".

Pan/Tilt EMS - Built-in electronic motion stabilizer ensures precise position of the fixture's head during its movement and also reducing its swinging when the truss shakes.

Follow Spot Mode - If the function is activated, the pan/tilt motors perform on lower power and the head position can be controlled manually. You can choose from three levels of the pan/tilt "consistency": soft, medium and hard. Note: reset of pan/tilt will not be executed if the fixture is in the Follow Spot Mode.

Theatre Mode - If the function is activated, the pan motor and tilt motor are slowed down to reduce noise of the pan/tilt movement.

Pan/Tilt Limitations - The function utilizes MAPS (Motionless Absolute Positioning system) which allows you to reduce range of pan and tilt movement by setting limits for both movements.

Pan Min. Value - Minimum pan movement value.

Pan Max. Value - Maximum pan movement value.

Tilt Min. Value - Minimum tilt movement value.

Tilt Max. Value - Maximum pan movement value.

If receiving DMX values are out of set limits, the fixture will not respond to them.

Example: Pan Min. Value=40 DMX, Pan Max. Value=120 DMX, the head will move in pan range of 40-120 DMX. Values under 40 and above 120 will not be used.

At reset of the head without connected DMX, the pan movement of the head will stop in the value 120 DMX.

After cancelling the pan movement limitation, the head will move to the value 128 DMX .

(Standard pan and tilt positions after reset of the head without DMX are 128 DMX, unless otherwise set in the menu Init Positions).

Microphone Sensitivity - Enter the menu if you want to adjust the microphone sensitivity from 1 (max.) to 20 (min.).

Blackout Settings - Use the menu if you need to close the light output under certain conditions which are described below

Blackout During MC - Blackout during movement correction. Set this option to "On" if you wish to close light output during the time when the head goes to its correct position from which has been changed by an external force.

Active Blackouts - Use this menu if you wish to close the light output during effect changes.

Pan/Tilt Moving - The menu item enables to close light output while the pan/tilt DMX values are changing.

Gobo Wheel Moving - The menu item enables to close light output while the rot. gobo carousel is moving.

Colour Calibration Mode - the function switches on/off an internal control of colours. For a standard operation of the fixture the option should be switched on. Option off has to be set during colour calibration of the fixture.

Colour Mixing Mode - This item allows selection between RGB and CMY mode. In both 3-colour controlling modes (Mode 1, Mode 2) all internal 5 colours are always utilized where possible

Chromatic White - If this function is on, the CTC channel influences colours and calibrated white colours. If this function is off, the CTC channel influences calibrated whites only.

Light Output Stability - If the function is on, the light output from the fixture is immediately reduced to a value corresponding to a thermal drop of the light intensity from the LED engine (the thermal drop - decreasing of the light intensity on 87 % of a starting level after first 5 minutes, then is the thermal drop inconsiderable).

Output Uniformity - if the function is on, the light intensity from the fixture is corrected in order to get approximately the same light intensity as from another fixture which has also the function on. Thanks to the function, light outputs from more fixtures will have approximately the same light intensity.

Frequency Setup - The function allows you to set the PWM (Pulse Width Modulation) output frequency of LEDs to 300Hz, 600Hz, 1200Hz or 2400Hz.

Frequency Adjust - The menu item allows you fine adjustment of the LED frequency around selected frequency.

User Colours - Use this menu to change the touch screen settings.

View User Colours - The item allows you to read DMX values of colour channels for each user colour (1-10).

Distribute User Colour - The item allows you to "send" user colours from this fixture to all connected Robin T.5 Profile fixtures by means of RDM protocol. User colours in the fixtures will be overwritten.

Tungsten effect simulation - This function simulates behaviour of a halogen lamp during dimming at calibrated whites 2700K-4200K. You can select from various lamp wattage simulation: 750W, 1000W, 1200W, 2000W, 2500W.

Init Effect Positions - Use the menu to set all effects to the desired positions at which they will stay after switching the fixture on without DMX signal received.

Reset Effect Positions - Use the menu item to reset effects in the menu "Init Effect Positions" to default (factory) values.

Screen Settings - Use this menu to change the touch screen settings.

Display Intensity - The item allows to control the intensity of the screen (1-min., 10-max.).

Screen saver Delay - The item allows you to keep the screen on or to turn it off automatically after 1-10 minutes after last touch (or pressing any button on the control panel).

Touchscreen Lock - The item allows you to lock the screen after last touch (or pressing any button on the control panel). The time delay can be set in range of 1-10 minutes. To unlock the screen, press the [ENTER/Display On] button.

Recalibrate Touchscreen - The item starts calibration of the touch screen. Follow the instructions on the screen.

Display Orientation - The menu allows to change display orientation.

Normal - Standard display orientation if the fixture is placed horizontally (e.g. on the ground).

Inverted - Inverted orientation (needed if the fixture is hanging on the truss).

Auto - The option activates a gravitation sensor for automatic screen orientation.

Note: **Auto** option is set as default. You change the display orientation by touching the icon  on the display, and the option set in the "Display Orientation" menu is temporarily overridden.

Temperature unit - Use the menu item to change temperature unit from °C to °F.

Fan Settings - Use the menu to set fans operation mode.

Fan Mode - Use the menu to set the fixture fans to max. power mode (option "**High**") or to the auto-control mode (option "**Auto**"). The option "**Quiet**" allows you to set desired fan noise.

The light output of the fixture is reduced at low speeds of fans. Last option "**Super Quiet**" provides extremely quiet operation of the fixture.

Quiet - Blackout Fan Off - The menu item allows you to stop all fans in the fixture (option "**On**") when its light output is closed (shutter in range of 0-31 DMX or dimmer in 0 DMX).

Dimmer Curve - Use the menu to select desired dimmer curve: Linear, Square Law or Super Square Law.

Gobo Indexing - The following three options define transition from gobo rotation to gobo indexing.

Max. Speed & Shortcut - Gobo goes from its rotation to desired indexed position with max. speed and via shortest track.

Follow Speed & Direction - Gobo goes from its rotation to desired indexed position with current speed and keeps a direction of rotation.

Max. Speed & Follow Dir. - Gobo goes from its rotation to desired indexed position with max. speed and keeps a direction of rotation.

Date & Time Settings - Use this menu to set current date and time for the fixture log system (menu "View Logs"). Set this menu items before first fixture operation.

Focus Tracking - This feature provides automatic sharpness re-adjustment during zoom movement, after an initial sharpness has been set by the operator by setting the focus channel and enabling the Focus Tracking. The Focus Tracking feature is done via automatic movement of focus element, taking into account several internal parameters, zoom position being one of them. To utilize the Focus Tracking, make sure to enable the Focus Tracking, set the Zoom to value 200 and adjust Focus to desired sharpness. Then, while keeping focus value untouched, you can move the Zoom. Fixture will automatically keep the projection at the desired sharpness as much as possible. You can also re-adjust the focus value over time if needed. When switching between Static gobo wheel, Rotating gobo wheel and an empty aperture, the Tracking Focus will adjust the internal parameters, therefore providing desired sharpness by adjusting the Focus might be required. If you use both Static gobo wheel and Rotating gobo wheel without further adjusting the focus value, Rotating gobo wheel will be automatically used for Focus Tracking 's focusing.

Default Settings - The menu item allows to set all fixture parameters in this menu to the default (factory) values except items "DMX Input".

Password Protection - allows to enter password in order to prevent unauthorized person from changing setting of the fixture. Password is set to 7623 and cannot be changed.

Reset Web Password - The menu item allows you to reset a password for access on the Web server (default password: 2479, user: robe).

7.4 Tab "Manual Control"



Reset Functions - The menu allows to reset the fixture either per function modules or all modules together.

Total System Reset - The item resets all function modules.

Pan/Tilt Reset - The item resets a pan and a tilt.

Gobo/Eff. Wh. Reset - The item resets static and rotating gobo wheel and an effect wheel.

Optics/Prism/Frost Res. - The item resets a zoom, focus, prism and a frost module.

Iris/Framing Sh. Reset - The item resets an iris module and framing shutters.

Manual Effect control - Use the menu to control all fixture channels by means of the control panel.

7.5 Tab "Stand-alone"



Cue Playback – This feature allows you to play cue recorded from DMX console which can be further edited on the display. This cue can also be created manually on the display. It's very useful for applications such as exhibition stands, galleries, car shows, museums and as a key light for illuminating presenters in ball rooms and auditoriums. The cue can be automatically initiated every time the fixture is turned On.

Test Sequences -Use the menu to run a test/demo sequences without an external controller, which will show you some possibilities of using the Robin T.5.

Dynamic Mode - This mode uses all Robin T.5 functions including pan/tilt movement and therefore is good for a complete introduction of the fixture.

Static Mode - This mode is suitable for projections on the wall, ceiling or ground without any pan/tilt movement. Adjust the pan, tilt, zoom and focus to desired positions and start test sequences by touching the green ► icon.

Music Trigger - Use the item to activate the sound control of the running program via the built-in microphone.

Preset Playback - This menu allows you to select a program which will be played in a loop after switching the fixture on.

None - The option disables "Preset playback" function.

Cue - The option starts saved cue.

Test - The option starts the test sequences.

Prog. 1 - The option starts user program No. 1.

Prog. 2 - The option starts user program No. 2.

Play program - Use the menu to run desired program in a loop.

Play Program 1 - The option starts user program No.1.

Play Program 2 - The option starts user program No. 2.

Edit Program - Use the menu to create or to edit desired program. The Robin T.5 offers two free programs, each up to 68 steps.

Edit Program 1 - The option allows you to edit user program 1.

Edit Program 2 - The option allows you to edit user program 2.

To edit program:

1. Touch the item which you want to edit ("Edit Program 1" - "Edit Program 2").
2. Touch the item "Edit Program Steps".
3. Touch the item "Step 1".

4. From the list of effects touch desired effect and set its value. Browse through the list by touching the [up arrow] and [down arrow] and set all desired effects.

An item "Step Time" (value of 0-25.5 sec.) is the time during which effects last in the current step

5. Save adjusted effects to the current step by touching the [confirm] or save and copy them to the following step by touching the [confirm+copy]. By touching the text box "Preview" next to the current program step you can view created scene.

6. Repeat the steps 4 and 5 for next program steps.

7. After editing desired program steps, adjust the length of the program by touching the text boxes "Start Step" and "End Step".

Meaning of the icons used in the "Edit Program" menu:

↓ - moves down on the next page

✓ - saves adjusted values and leaves menu

↑ - moves up on the previous page

✓ - saves values to the current step and copy them to the following prog. step

✗ - leaves menu without saving values

7.6 Tab "Service"



Adjust DMX Values - The menu allows you to set all effects to desired positions before fine calibration of the effects .

Calibrations - This menu enables fine calibration of fixture effects and download default calibration values.

Calibrate Effects - The menu allows the fine adjustment of effects.

Pan - a pan position fine adjustment (value range: 0-255)

Tilt - a tilt position fine adjustment (value range: 0-255)

Effect Wheel - an effect wheel position fine adjustment (value range: 0-255)

Rot. Gobo Wheel - a carousel of rotating gobos fine movement (value range: 0-255)

R. Gobo Index 1 - a fine movement of the rotating gobo 1 (value range: 0-255)

R. Gobo Index 2 - a fine movement of the rotating gobo 2 (value range: 0-255)

R. Gobo Index 3 - a fine movement of the rotating gobo 3 (value range: 0-255)

R. Gobo Index 4 - a fine movement of the rotating gobo 4 (value range: 0-255)

R. Gobo Index 5 - a fine movement of the rotating gobo 5 (value range: 0-255)

R. Gobo Index 6 - a fine movement of the rotating gobo 6 (value range: 0-255)

R. Gobo Index 7 - a fine movement of the rotating gobo 7 (value range: 0-255)

Prism 1 - a prism fine movement (value range: 0-255)

Prism 2 - a prism fine rotation (value range: 0-255)

Zoom - a zoom module fine movement (value range: 0-255)

Focus - a focus module fine movement (value range: 0-255)

Iris - an iris fine movement (value range: 0-255)

Frost 1/1 - a light frost fine position movement 1

Frost 1/2 - a light frost fine position movement 2

Frost 2/1 - a medium frost fine position movement 1

Frost 2/2 - a medium frost fine position movement 2

Fr. Shutters.rot - a framing shutters module fine rotation (value range: 0-255)

Fr. Shutter 1 Move - a Fram. lamella 1 fine moving

Fr. Shutter 1 Swiv. - a Fram. lamella 1 fine swivelling

Fr. Shutter 2 Move - a Fram. lamella 2 fine moving

Fr. Shutter 2 Swiv. - a Fram. lamella 2 fine swivelling

Fr. Shutter 3 Move - a Fram. lamella 3 fine moving

Fr. Shutter 3 Swiv. - a Fram. lamella 3 fine swivelling

Fr. Shutter 4 Move - a Fram. lamella 4 fine moving

Fr. Shutter 4 Swiv. - a Fram. lamella 4 fine swivelling

Calibration of the effects via the control board

1. Disconnect DMX controller from the fixture and enter the "Calibrate Effects" menu.

2. Use the [up arrow] and [down arrow] to find "Pan" and touch it to enter the fine effect adjustment screen.

3. Set desired value and save it by touching the [confirm].

4. Repeat steps 2 and 3 for next item

5. After calibrating all effects, touch the [confirm] to save all adjusted values and reset the fixture.

Calibration of the effects via the DMX controller

1. Connect DMX controller to the fixture and enter the "Calibrate Effects" menu.

Calibration protocol:

Effect	Mode 1	Mode 2	Mode 3
Pan	channel 50	channel 34	channel 54
Tilt	channel 51	channel 35	channel 55
Ef. wheel	channel 52	channel 36	channel 56
Rot. Gobo Wheel	channel 53	channel 37	channel 57
R. Gobo Index 1	channel 54	channel 38	channel 58
R. Gobo Index 2	channel 55	channel 39	channel 59
R. Gobo Index 3	channel 56	channel 40	channel 60
R. Gobo Index 4	channel 57	channel 41	channel 61
R. Gobo Index 5	channel 58	channel 42	channel 62
R. Gobo Index 6	channel 59	channel 43	channel 63
R. Gobo Index 7	channel 60	channel 44	channel 64
Prism 1	channel 61	channel 45	channel 65
Prism 2	channel 62	channel 46	channel 66
Zoom	channel 63	channel 47	channel 67
Focus	channel 64	channel 48	channel 68
Iris	channel 65	channel 49	channel 69
Frost 1/1	channel 66	channel 50	channel 70
Frost 1/2	channel 67	channel 51	channel 71
Frost 2/1	channel 68	channel 52	channel 72
Frost 2/2	channel 69	channel 53	channel 73
Fr. Shutters rot.	channel 70	channel 54	channel 74
Fr. Shutter 1 Move	channel 71	channel 55	channel 75
Fr. Shutter 1 swivelling.	channel 72	channel 56	channel 76
Fr. Shutter 2 Move	channel 73	channel 57	channel 77
Fr. Shutter 2 swivelling	channel 74	channel 58	channel 78
Fr. Shutter 3 Move	channel 75	channel 59	channel 79
Fr. Shutter 3 swivelling	channel 76	channel 60	channel 80
Fr. Shutter 4 Move	channel 77	channel 61	channel 81
Fr. Shutter 4 swivelling	channel 78	channel 62	channel 82

Calibrate Fr. Hysteresis

Framing Lamella 1 - a framing lamella 1 reverse movement (value range: 0-8)

Framing Lamella 2 - a framing lamella 1 reverse movement (value range: 0-8)

Framing Lamella 3 - a framing lamella 1 reverse movement (value range: 0-8)

Framing Lamella 4 - a framing lamella 1 reverse movement (value range: 0-8)

The value set for every framing lamella gives a value at which the lamella reacts to its reverse movement promptly (without movement hysteresis).

Calibrate Colours - The menu serves for calibration of colours in a factory. The user should not change the settings in this menu.

Green Corrections - The menu allows you to correct calibrated whites 2700K, 3200K, 4200K, 5600K and 8000K. Both shutter and dimmer must be open during the correction.

The green correction can be also done by DMX commands. In this case you have go on the option "Green correction calibration" (210-211.DMX) on the channel Power/Special function and on the channel Colour functions select desired colour temperature and CRI (145-194 DMX) and by means of the channel Green correction set desired light output. After adjustment of desired colours, go on the option "Save green correction " (195-199 DMX) and stay on it for 3 sec. to save adjusted colours.

Calibrate Pan/Tilt EMS - This menu item allows calibration of the pan/tilt electronic motion stabilizer. Important: during this calibration any external force must not influence the fixture and the surface at which the fixture stands (or truss if the fixture hangs) has to be without movement, shake, strokes etc.

Calibrate Pan/Tilt Reset - The menu item is used for calibration of pan/tilt reset in factory and also has to be used in case of change of pan or tilt motor or pan/tilt control PCB RB3138 in the fixture arm.

Load Default Calibrations - The item loads default (factory) calibration values.

LEDs Current Calibration - This process waits about 5 minutes and after its finishing the sign "Current Calibration DONE" will appear on the display. The procedure should be run if some colour non uniformity has occurred during fixture operation.

Important. The procedure must be run after LEDs module changing or LEDs driver PCB (RB 3415) changing, otherwise damage of LEDs module may occur! This calibration of LEDs current must be run before dimmer activation!

Note: Calibration of LEDs current can be also run by means of the RDM manager ver. 1.0.12 and higher (LED Driver -->Start Current Calibration).

Rotating Gobos Change - This menu makes changing of rotating gobos in the fixture easier.

Gobo Carousel 1 - The menu allows movement of rotating gobos on the gobo carousel 1 to positions suitable for their changing.

G1-Mg - a movement of the gobo 1 (gobo holder with magnet) to the changing position.

G2 - a movement of the gobo 2 to the changing position.

:

G7 - a movement of the gobo 7 to the changing position.

Gobo Offset -a gobo offset setting. The function allows fine swivelling of the gobo holder. The set value is valid for all gobos on the gobo carousel.

LEDS HW version - The item shows a hardware versions of the LED engine:

LEDs Measure - This menu item runs a procedure which measures a light intensity of the LEDs module installed in the fixture. This procedure takes about 1 minute (message " LEDs Module Measurement" is displayed on the screen"). During the procedure the fixture does not receive DMX signal, pan/tilt go to 128 DMX, a shutter is open and a dimmer is set at max. light intensity (255 DMX). All effects are taken out from the light beam. The LEDs Measure procedure should be run after every change of the LED light source.

Note: The fixture has to be connected to mains in order to run LEDs Measure procedure.

Update software - The menu item allows you to update software in the fixture.

The following items are required in order to update software:

- PC running Windows or Linux or macOS
- DSU file
- Flash cable RS232/DMX, P/N13050624 (if you want to use a serial port of PC)
- Robe Universal Interface or Robe Universal interface WTX (if you want to use an USB port of PC)

After the software updating the fixture will be set to default values.

To update software in the fixture:

1. DSU file is available from Robe web site at WWW.robe.cz.
File with extension zip is intended for Windows (used and tested from XP to W10 on 32/64bit systems).
File with extension tbz is intended for Linux (used and tested on Debian and Ubuntu 32/64bit).
File with extension dmg is intended for macOS (used and tested on OSX up to Sierra) XQuartz required, install it from <https://www.xquartz.org/>
Save the download file to a folder on your computer.
In case that you use windows, extract files in the zip file (e.g. DSU_RobinT.5Profile_18100828.zip)
2. Disconnect the fixture from DMX controller.
3. If you use the flash cable RS232/DMX, connect a serial port of your computer with DMX input of the fixture by means of the cable.
If you use the Robe Universal Interface, connect a USB port of your computer with the Robe Universal Interface by means of the USB cable and DMX input of the fixture with the DMX output of the Robe Universal Interface via a DMX cable.
4. Switch the fixture to the update mode (tab "Service" --> Update Software).
Note: If you do not want to continue in the software update, you have to switch off and on the fixture to escape from the updating mode.
We recommend to cancel all running programs on your computer before starting the software update.
5. Double-click the software uploader file (e.g. DSU_RobinT.5Profile_18100828.exe) in the extracted files. The Software Uploader program will start running.

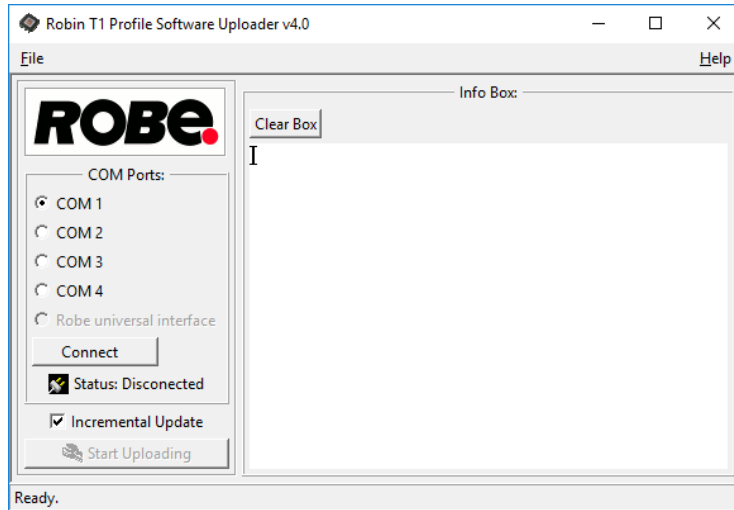

6. Select correct "COM " number if you use a Flash cable RS232/DMX or select "Robe Universal Interface " if you use the Robe Universal Interface/Robe Universal Interface WTX and then click on the "Connect" button.
7. If the connection is OK, click the "Start Uploading" button to start software uploading. It will take several minutes to perform software update.

If the option "Incremental Update" is not checked, all processors will be updated (including processors with the same software version).

If you wish to update only processors with new version of software, check the "Incremental Update box".

Avoid interrupting the process. Update status is being displayed in the "Info Box" window.

When the update is finished, the line with the text "Fixture is successfully updated" will appear in this window.

In case upload process is interrupted (e.g. power loss), the fixture stays in "Updating mode" and you will have to repeat the software update again.

Another way, how to update software in the fixtures (especially large installation of fixtures) is to use the ROBE Uploader. It is a software for automatized software update of Robe fixtures. It takes advantage of RDM support).

For more information please see <https://www.robe.cz/robe-uploader/>.

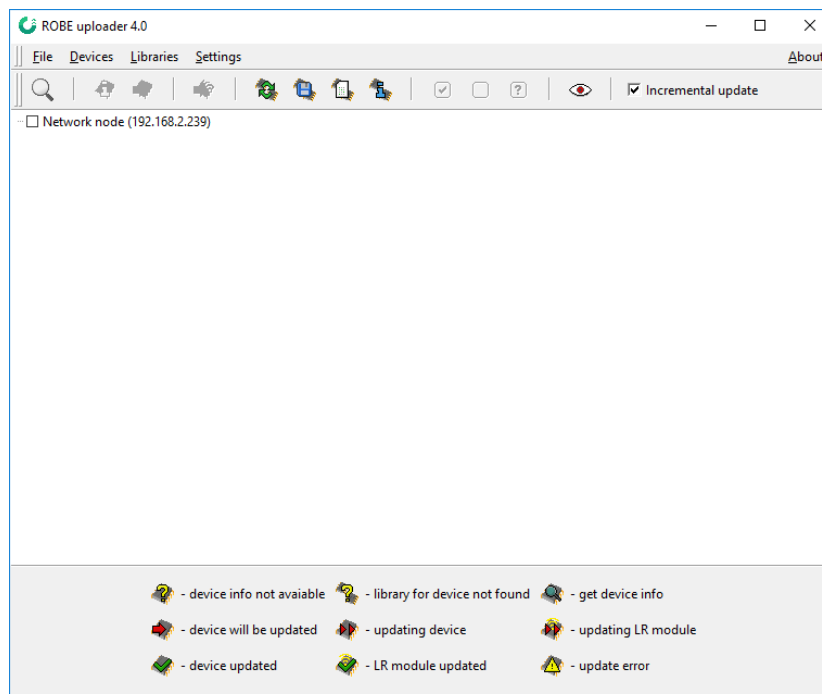

8. RDM

This fixture supports RDM operation. RDM (Remote Device Management) is a bi-directional communications protocol for use in DMX512 control systems, it is the new open standard for DMX512 device configuration and status monitoring.

The RDM protocol allows data packets to be inserted into a DMX512 data stream without adversely affecting existing non-RDM equipment. By using a special „Start Code,“ and by complying with the timing specifications for DMX512, the RDM protocol allows a console or dedicated RDM controller to send commands to and receive messages from specific moving lights.

RDM allows explicit commands to be sent to a device and responses to be received from it.

The list of commands for Robin T.5 Profile is the following.

Parameter ID	Discovery command	SET command	GET command
DISC_UNIQUE_BRANCH	*		
DISC_MUTE	*		
DISC_UN_MUTE	*		
DEVICE_INFO			*
SUPPORTED_PARAMETERS			*
SOFTWARE_VERSION_LABEL			*
DMX_START_ADDRESS		*	*
IDENTIFY_DEVICE		*	*
DEVICE_MODEL_DESCRIPTION			*
MANUFACTURER_LABEL			*
DEVICE_LABEL		*	*
SENSOR_DEFINITION			*
SENSOR_VALUE			*
DISPLAY_INVERT		*	*
DISPLAY_LEVEL		*	*
PAN_INVERT		*	*
TILT_INVERT		*	*
DEVICE_RESET		*	
DMX_PERSONALITY		*	*
DMX_PERSONALITY_DESCRIPTION			*
STATUS_MESSAGES			*
STATUS_ID_DESCRIPTION			*

RDM model ID for the Robin T.5 Profile is 0x014f.

9. Error and information messages

Information icons



- Air Filters Cleaning

This icon signals that cleaning period of the air filters has elapsed and you have to clear air filters and reset the menu item "Elapsed Time".

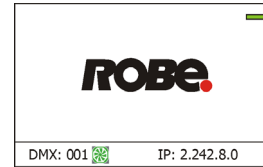

Errors

Error in the fixture is signalled by the yellow warning icon at the bottom line of the screen:



Touch the warning icon or press the [ESCAPE] button to display error messages.
List of error and information messages:

Pan Error 1

Pan sensor is not in a function state "connected".

Pan Error 2

Pan sensor is not in a function state "unconnected".

Pan Error 3

Pan feedback error.

Tilt Error 1

Tilt sensor is not in a function state "connected".

Tilt Error 2

Tilt sensor is not in a function state "unconnected".

Tilt Error 3

Tilt feedback error.

Prism Error 1

Impact to the mechanical end of the prism wheel track was not detected.

Prism Error 4

Incorrect detection of a prism wheel track. Impact to a mechanical obstruction was detected within running of the prism .

Iris Error 1

Impact to the mechanical end of the iris track was not detected.

Iris Error 4

Incorrect detection of a iris track. Impact to a mechanical obstruction was detected within running of the iris.

Frost 1 Error 1

Impact to the mechanical end of the frost track was not detected.

Frost 1 Error 4

Incorrect detection of a frost track. Impact to a mechanical obstruction was detected within running of the frost.

Frost 2 Error 1

Impact to the mechanical end of the frost track was not detected.

Frost 2 Error 4

Incorrect detection of a frost track. Impact to a mechanical obstruction was detected within running of the frost.

Zoom Error 1

Impact to the mechanical end of the zoom track was not detected.

Zoom Error 4

Incorrect detection of a zoom track. Impact to a mechanical obstruction was detected within running of the zoom.

Focus 1 Error 1

Impact to the mechanical end of the focus module track was not detected.

Focus Error 4

Incorrect detection of a focus track. Impact to a mechanical obstruction was detected within running of the focus module.

Gobo Carousel Error 1

Magnetic/optic sensor was not detected.

Gobo Carousel Error 2

Magnetic/optic sensor permanently detects gobo carousel.

Gobo Rotation Error 1

Magnetic/optic sensor was not detected on the rotating gobo on the gobo carousel.

Gobo Rotation Error 2

Magnetic/optic sensor permanently detects rotating gobo on the gobo carousel.

Effect Wheel Error 1

Impact to the mechanical end of the effect wheel track was not detected.

Effect Wheel Error 4

Incorrect detection of an effect wheel track. Impact to a mechanical obstruction was detected within running of the effect wheel.

Fr. Shutters Rot. Error 1

Impact to the mechanical end of the framing shutters wheel was not detected.

Fr. Shutters Rot. Error 2

Incorrect detection of the framing shutters wheel. Impact to a mechanical obstruction was detected within running of the framing shutters wheel.

Fr. Shutter 1 Error 1

Impact to the mechanical end of the framing shutter 1 was not detected.

Fr. Shutter 1 Error 4

Incorrect detection of the framing shutter 1. Impact to a mechanical obstruction was detected within running of the framing shutter 1.

Fr. Shutter 2 Error 1

Impact to the mechanical end of the framing shutter 2 was not detected.

Fr. Shutter 2 Error 4

Incorrect detection of the framing shutter 2. Impact to a mechanical obstruction was detected within running of the framing shutter 2.

Fr. Shutter 3 Error 1

Impact to the mechanical end of the framing shutter 3 was not detected.

Fr. Shutter 3 Error 4

Incorrect detection of the framing shutter 3. Impact to a mechanical obstruction was detected within running of the framing shutter 3.

Fr. Shutter 4 Error 1

Impact to the mechanical end of the framing shutter 4 was not detected.

Fr. Shutter 4 Error 4

Incorrect detection of the framing shutter 4. Impact to a mechanical obstruction was detected within running of the framing shutter 4.

EEPROM Error

Hardware error of the EEPROM.

Recharge The battery

The battery on the display board needs to be charged. Let the fixture on for cca 6 hrs.

Battery Faulty. Replace it.

The battery on the display board is exhausted and should be replaced immediately.

Pan/Tilt EMS Cal. Error

The EMS system is not calibrated.

Pan/Tilt EMS Error

Control electronics cannot communicate with the EMS system.

Internal Error 1

Communication error between PCBs (error or noise was detected on communication wires)

Internal Error 2

Communication error (some PCB has failed or is disconnected (this PCB will show as N/A in menu --> Information --> Software versions) or error/noise was detected on communication wires)

Clean Air Filters

The message informs you that the item "Elapsed Time" in the "Fixture Information" menu is at 0 value. Clean air filters and reset this counter.

Blue 1 Short Error/ Blue 2 Short Error/ Blue 3 Short Error/ Blue 4 Short Error

Some blue LEDs in the light source have short circuit or are disconnected.

Green 1 Short Error/ Green 2 Short Error

Some green LEDs in the light source have short circuit or are disconnected.

Light Green 1 Short Error/ Light Green 2 Short Error/ Light Green 3 Short Error/ Light Green 4 Short Error

Some light green LEDs in the light source have short circuit or are disconnected.

Amber 1 Short Error/ Amber 2 Short Error/ Amber 3 Short Error/ Amber 4 Short Error

Some amber LEDs in the light source have short circuit or are disconnected.

Red 1 Short Error/ Red 2 Short Error/ Red 3 Short Error/ Red 4 Short Error

Some red LEDs in the light source have short circuit or are disconnected.

LEDs Colour Cal. Missing

Colour calibration of the light source was not done, e.g. after MSL light source change.

LEDs Current Cal. Missing

LEDs current calibration was not done. Go to the tab Service and run the item LEDs Current Calibration.

Base Fan Bad

The fan in the fixture base is disconnected from its control PCB or is faulty and should be replaced. A light output from the fixture is closed.

Suction LED Fan 1 Bad/ Suction LED Fan 2 Bad

The suction fan 1 (fan 2) at the LED engine is disconnected from its control PCB or is faulty and should be replaced.

Exhaust LED Fan 1 Bad/ Exhaust LED Fan 2 Bad

The exhaust fan 1 (fan 2) at the LED engine is disconnected from its control PCB or is faulty and should be replaced.

Positions of fans (and their control PCBs):

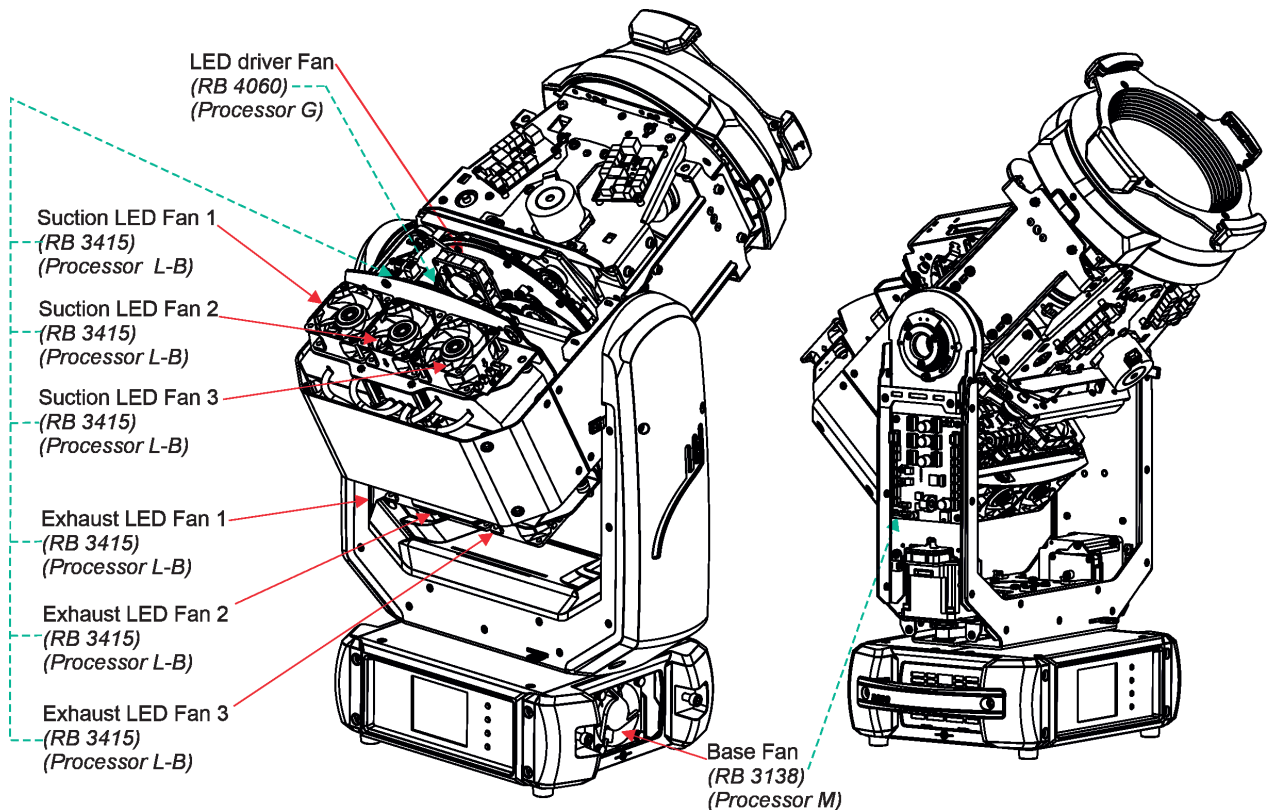

10. Robe Ethernet Access Portal (REAP)

The REAP allows you to display on your computer information about some fixture settings, operating conditions (e.g. temperature in the fixture) and error messages which were generated during fixture operation. Your computer needs to be connected to the fixture(s) through the means of Ethernet wired network and a network switch.

The Ethernet network connection (Local LAN) typically needs to be set to 2.x.x.x address, assuming that no other computer on the network contains such an address while keeping all ROBE fixtures in default IP settings.

For more information about REAP options, computer and fixture settings please see the REAP user manual at https://www.robe.cz/res/downloads/user_manuals/User_manual_REAP.pdf.

11. Technical Specifications

Electrical

Power supply: electronic auto-ranging
Input voltage range: 100-240V, 50-60Hz
Fuse: T 6.3 A
Max. power consumption: 480W (power factor 0.98)
Mains output: max. 12A

Optic

Light source type: MSL™ 350W Multi-Spectral LED engine
CMY/RGB colour mixing
CRI setting range: Standard (80) - High (90+)
Typical lumen maintenance: L70/B50 @ 40.000 hours

Virtual colour wheel

67 preset colours
70 preset multicolours
10 user colours
Rainbow effect with variable speed

Colour temperature correction

White light: Variable CCT 2700K – 8000K
Halogen lamp effect at whites 2700K- 4200K

Effect wheel

Aluminium effect wheel rotating in both directions with variable speed

Rotating gobo wheel

7 glass gobos can be indexed and rotated in both directions at different speeds,
gobo wheel continuous rotation
Gobos: outside diameter= 22.3^{+0,1} mm, image diameter=18 mm, thickness=1-3.5 mm, high
temperature borofloat or better glass.

"Slot&lock" system for easy replacement of gobos

Gobos order:

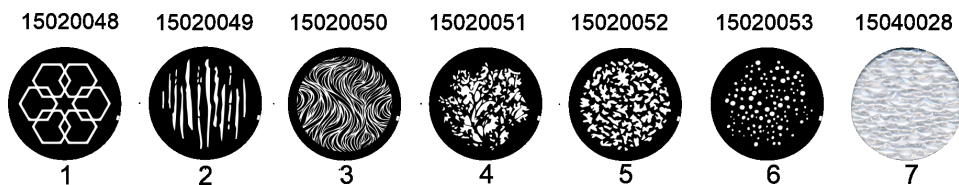

Note. Steel (or aluminium) gobos cannot be used due to thermal stress.

Prism

Rotating 6-facet 8° prism with continuous rotation in both directions

Iris

Motorized iris for different beam diameters

Frost filters

2 separate, variable frost filters, light (1°) and medium (5°)
The medium filter is replaceable

Framing shutters module

Full curtain framing shutters and rotation of the complete frame system +/- 60°
Each framing shutter can be swiveled

Zoom

Linear motorized zoom
Min. beam angle :5°
Max. beam angle: 55°

Strobe

Strobe effect with variable speed (0.3 - 20Hz)

Dimmer

Smooth dimmer from 0 - 100 %

Control

Graphic touch screen for fixture setting and addressing
Gravitation sensor for auto screen positioning
Battery backup of the touch screen
Readout fixture and LEDs usage, receiving DMX values, temperatures, etc
Built-in analyzer for easy fault finding, error messages
Silent fans cooling
Stand-alone operation
3 user editable programs, each up to 100 steps
Supported protocols: USITT DMX 512, RDM, ArtNet, MANet, MANet2, sACN
Support of RDM (Remote Device Management)
3 DMX modes (49, 33, 53 control channels)

Wireless DMX/RDM module type RW 001 (only wireless DMX version of the fixture)

Supported protocols: full RDM support, CRMX , W-DMX™ G2, G3,G4 and G4S
Operational frequency range: 2402-2480 MHz
Output power: 100 mW
Receiver sensitivity (0.1% BER): -93 dBm
Crystal Clock Frequency : 16.0 MHz

Pan/Tilt

Pan movement range 540°
Tilt movement range 265°
16 bit movement resolution
Pan/Tilt electronic motion stabilizer (EMS™)
Motionless absolute positioning system for Pan and Tilt (MAPS™)
Remotely controllable speed of pan/tilt movement for easy programming
Pan/tilt-lock mechanism

Max. number of fixtures in Ethernet IN/Out line (EP version only)

8

Connection

DMX data in/out: Locking 3-pin and 5-pin XLR
AC power input: Chassis connector Neutrik PowerCon TRUE 1, NAC3MPX
Ethernet: 1 x RJ45
Ethernet: 2 x RJ 45 (T.5 EP version only)

Rigging

Mounting points: 2 pairs of 1/4-turn locks
Mounting horizontally or vertically via 2 Omega brackets

Temperatures

Maximum/Minimum ambient operating temperature : +45°C/-5°C
Maximum housing temperature : 70° C

Minimum distances

Min. distance from flammable surfaces: 1 m
Min. distance to lighted object: 4 m

Total heat dissipation

1313 BTU/hr (calculated)

Weight

20.8 kg

Ingress protection rating

IP20

Dimensions (mm)

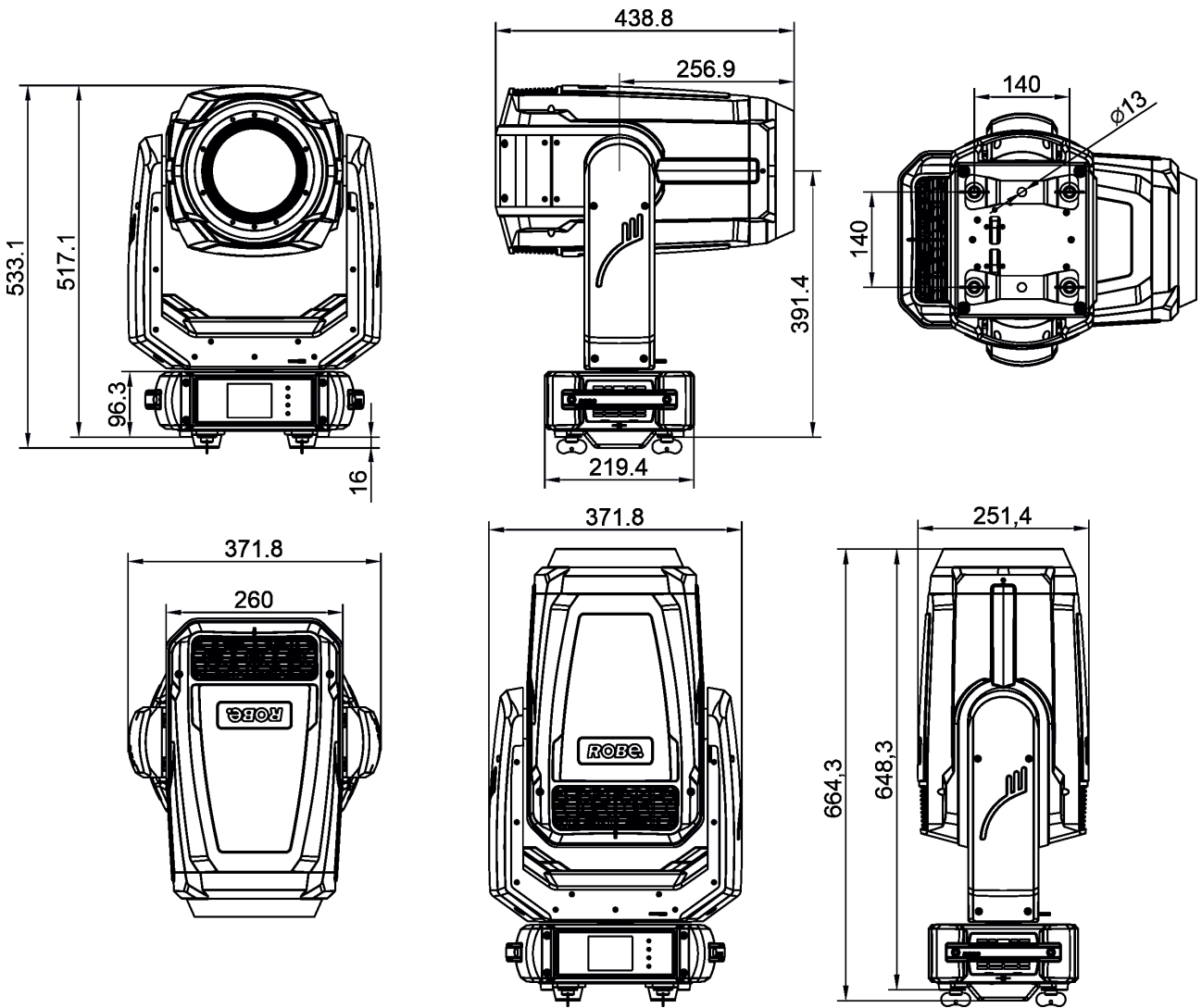

Accessories

- 1 x Omega adaptor CL-regular 2 pcs in box (P/N 10980033)
- 1 x Power cable including powerCON TRUE1
- 1 x Gel Frame adaptor installed on the fixture head

Optional accessories

- Doughty Trigger Clamp (P/N 17030386)
- Safety wire 36 kg (P/N 99011963)
- Frost 0,5° (exchange) for Robin T.5 (P/N 0981149)
- Frost 1° (exchange) for Robin T.5 (P/N 0981150)

Frost 5° (exchange) for Robin T.5 (P/N 0981151)
Frost 10° (exchange) for Robin T.5 (P/N 0981152)
Frost 20° (exchange) for Robin T.5 (P/N 0981153)
Frost 30° (exchange) for Robin T.5 (P/N 0981154)
Mains Cable powerCON TRUE1 In/Schuko, 2m, Indoor (P/N 13052405)
Mains Cable powerCON TRUE1 In/US, 2m, Indoor (P/N 13052406)
Daisy Chain powerCON TRUE1 In/Out, EU, 2m, Indoor (P/N 13052439)
Mains Cable powerCON TRUE1 In/CEE 16A, 2m, Indoor (P/N 13052445)
Mains Cable powerCON TRUE1 In/Open ended, 2m, Indoor (P/N 13052407)
Daisy Chain powerCON TRUE1 In/Out, US, 2m, Indoor (P/N 13052440)
Daisy Chain powerCON TRUE1 In/Out, EU, 5m, Indoor (P/N 13052444)
kit Upgrade kit CRMX Universal 260 (P/N 99030100)

12. Maintenance and cleaning

It is absolutely essential that the fixture is kept clean and that dust, dirt and smoke-fluid residues must not build up on or within the fixture. Otherwise, the fixture's light-output will be significantly reduced. Regular cleaning will not only ensure the maximum light-output, but will also allow the fixture to function reliably throughout its life. A soft lint-free cloth moistened with any good glass cleaning fluid is recommended, under no circumstances should alcohol or solvents be used!

DANGER !
***Disconnect from the mains before starting any
maintenance work***

The front objective lens will require weekly cleaning as smoke-fluid tends to building up residues, reducing the light-output very quickly. The cooling-fans should be cleaned monthly.

The interior of the fixture should be cleaned at least annually using a vacuum-cleaner or an air-jet.

Gobo wheels and the internal lenses should be cleaned monthly.

Remove dust and dirt from the fans and cooling vents using a soft brush and vacuum-cleaner.

***Important! Check the air filters periodically and clean before they become
clogged!***

Clean the air filters placed in the base. Use a vacuum cleaner, compressed air or you can wash them and put back dry.

After replacing the air filters, reset the elapsed time counter in the menu "Information"
(Information--->Air Filters---> Elapsed Time).

The guide rods of zoom module should be lubricated monthly (or according to the current situation of movement of zoom module). Use a suitable lubricant (e.g. oil Aronix /100ml/, P/N 90031114).

Replacing the fuse.

Before replacing the fuse, unplug mains lead.

1. Remove the fuse holder on the rear panel of the base with a fitting screwdriver from the housing (anti-clockwise).
2. Remove the old fuse from the fuse holder.
3. Install the new fuse in the fuse holder (only the same type and rating).
4. Replace the fuse holder in the housing and fix it.

Checking plastic parts of the fixture.

The plastic parts of the fixture should be checked for damages and beginning cracks at least every two months. In addition, the plastic part of the front lens has to be checked mechanically (by means of movement by the plastic part) if it is firmly fastened to the fixture. If hint of a crack is found on some plastic part, do not use the fixture until the damaged part will be replaced.

Cracks or another damages of the plastic parts can be caused by the fixture transportation or manipulation and also ageing process may influence plastic materials.

This checking is necessary for both fixed installations and preparing fixtures for renting. Any free moving parts inside of the fixture head, cracked plastic or any plastic part of front lens not sitting properly in place need to be immediately replaced.

12.1 Disposing of the product

To preserve the environment please dispose or recycle this product at the end of its life according to the local regulations and codes.

13. ChangeLog

This section summarizes changes in the user manual.

Version of the manual	Date of issue	Description of changes

December 12, 2024

Copyright © 2024 Robe Lighting - All rights reserved

All Specifications subject to change without notice

Made in CZECH REPUBLIC by ROBE LIGHTING s.r.o. Palackeho 416/20 CZ 75701 Valasske Mezirici



DMX protocol

Robin T.5 Profile - DMX protocol

Version: 1.2 Mode 1-CMY/RGB, Mode 2 -Reduced CMY/RGB, Mode 3-Five colours (R,G,B,A,Lime)

Quick overview of default DMX values for each channel

Mode/channel			Default DMX Value	Function
1	2	3		
1	1	1	128	Pan
2	2	2	0	Pan Fine
3	3	3	128	Tilt
4	4	4	0	Tilt fine
5	5	5	0	Pan/Tilt speed , Pan/Tilt time
6	6	6	0	Power/Special functions
7	*	7	10	LED frequency selection
8	*	8	128	LED frequency fine adjusting
9	7	9	0	Colour functions
10	8	10	0	CRI selection
11	*	11	0	Virtual colour wheel
12	9	*	0/255	Cyan/Red (8 bit)
13	*	*	0/255	Cyan/Red (16 bit)
14	10	*	0/255	Magenta/Green (8 bit)
15	*	*	0/255	Magenta/Green (16 bit)
16	11	*	0/255	Yellow/Blue (8 bit)
17	*	*	0/255	Yellow/Blue (16 bit)
*	*	12	255	Red (8 bit)
*	*	13	255	Red (16bit)
*	*	14	255	Green (8 bit)
*	*	15	255	Green (16bit)
*	*	16	255	Blue (8 bit)
*	*	17	255	Blue (16bit)
*	*	18	255	Amber (8 bit)
*	*	19	255	Amber (16bit)
*	*	20	255	Lime (8 bit)
*	*	21	255	Lime (16bit)
18	12	22	110	CTC
19	*	23	128	Green correction
20	*	24	0	Colour mix control
21	*	25	0	Speed of rot. Gobo selection
22	*	26	0	Rot. Gobo carousel/ Framing shutters/Zoom/Focus/Iris/Frost/Prism time
23	13	27	0	Effect wheel positioning
24	14	28	128	Effect wheel rotation
25	*	29	0	Effect wheel animations
26	15	30	0	Rotating gobo wheel
27	16	31	128	Rot. gobo indexing and rotation
28	*	32	0	Rot. gobo indexing/rotation - fine
29	17	33	0	Prism
30	18	34	128	Prism indexing/rotation
31	19	35	0	Frost
32	20	36	0	Iris

DMX protocol

Mode/channel			Default DMX Value	Function	
1	2	3			
33	*	37	0	Iris - fine	
34	21	38	128	Zoom	
35	*	39	0	Zoom - fine	
36	22	40	128	Focus	
37	*	41	0	Focus - fine	
38	23	42	128	Framing shutters module rotation	
39	24	43	0	Framing shutter 1- movement	
40	25	44	128	Framing shutter 1- swivelling	
41	26	45	0	Framing shutter 2- movement	
42	27	46	128	Framing shutter 2- swivelling	
43	28	47	0	Framing shutter 3 movement	
44	29	48	128	Framing shutter 3- swivelling	
45	30	49	0	Framing shutter 4 movement	
46	31	50	128	Framing shutter 4- swivelling	
47	32	51	32	Shutter/ strobe	
48	33	52	0	Dimmer intensity	
49	*	53	0	Dimmer intensity - fine	
Mode/channel			DMX Value	Function	Type of control
1	2	3			
1	1	1	0 - 255	Pan Pan movement by 540° (128=default)	proportional
2	2	2	0 - 255	Pan Fine Fine control of pan movement (0=default)	proportional
3	3	3	0 - 255	Tilt Tilt movement by 265° (128=default)	proportional
4	4	4	0 - 255	Tilt fine Fine control of tilt movement (0=default)	proportional
5	5	5	0	Pan/Tilt speed , Pan/Tilt time Standard mode (0=default)	step
			1	Max. Speed Mode	step
			2 - 255	Pan/Tilt speed mode Speed from max. to min.	proportional
			2 - 255	Pan/Tilt time mode Time from 0.2 sec. to 25.5 sec.	proportional
6	6	6	0 - 9	Power/Special functions Factory display menu setting: DMX Input-Wired ,Graphic display-On, Pan/tilt Mode-Speed,Blackout while pan/tilt moving-Off, Blackout while gobo wheel moving-Off, Fans mode-Auto Reserved (0=default) <i>To activate following functions, stop in DMX value for at least 3 s and shutter must be closed at least 3 sec. („Shutter,Strobe“ channel 47/32/51 must be at range: 0-31 DMX). Corresponding menu items are temporarily overridden.</i>	
			10-14	DMX input: Wired DMX *	step
			15-19	DMX input: Wireless DMX *	step
* function is active only 10 seconds after switching the fixture on					

DMX protocol

Mode/channel			DMX Value	Function	Type of control
1	2	3			
			20-24	Graphic display: On	step
			25-29	Graphic display: Off	step
			30-39	Reserved	step
			40-44	Pan/Tilt mode: Speed	step
			45-49	Pan/Tilt mode: Time	step
			50-54	Blackout while pan/tilt moving: On	step
			55-59	Blackout while pan/tilt moving: Off	step
			60-64	Blackout while gobo wheel moving: On	step
			65-69	Blackout while gobo wheel moving: Off	step
			70-74	Fans mode: Auto	step
			75-79	Fans mode: High	step
			80-84	Quiet mode: Fans On at blackout	step
			85-89	Quiet mode: Fans Off at blackout	step
			90-119	Reserved	
			120-124	Parking position On	step
			125-129	Parking position Off	step
				<i>To activate following functions, stop in DMX value for at least 3 seconds.</i>	
			130 - 139	Fixture reset (except pan/tilt)	
			140 - 149	Pan/Tilt reset	step
			150 - 159	Reserved	step
			160 - 169	Gobo wheel/effect wheel reset	step
			170 - 179	Reserved	
			180 - 189	Zoom/focus/frost/prism reset	step
			190 - 199	Iris /framing shutters reset	step
			200 - 209	Total fixture reset	step
			210 - 211	Green correction calibration	step
			212 - 218	Reserved	
				The following three commands define transition from gobo rotation to gobo indexing:	
			219 - 220	Maximum speed and shortcut	step
			221 - 222	Follow speed and direction	step
			223 - 224	Maximum speed and follow direction	step
				The following RoboSpot related commands are only applicable when the RoboSpot is connected:	
			225 - 229	RoboSpot enabled	step
			230 - 234	RoboSpot disabled - except handle faders and pan/tilt	step
			235 - 239	RoboSpot fully disabled	step
			240	Disabled "Quiet mode"	step
			241 - 255	Quiet mode - fan noise control from min. to max.	proportional
7	*	7		LED frequency selection	
				Factory display menu setting: 600Hz	
				<i>Select PWM output frequency of LEDs. Selected PWM frequency can be fine adjusted in 127 steps up/down around selected PWM frequency on the channel below. Corresponding menu item (Frequency Setup) is temporarily overridden.</i>	
			0-4	PWM frequency from Display menu (fixture utilizes PWM frequency set in the display menu item Frequency Setup).	step
			5-9	300 Hz	step
			10-14	600 Hz (10=default)	step

DMX protocol

Mode/channel			DMX Value	Function	Type of control
1	2	3			
			15-19	1200 Hz	step
			20-24	2400 Hz	step
			25-255	Reserved (fixture utilizes PWM frequency set in the display menu item Frequency Setup).	
8	*	8		LED frequency fine adjusting Factory display menu setting: 600Hz <i>Select desired PWM output frequency of LEDs on the channel above.</i>	
			0-1	Selected LED Frequency	step
			2	LED Frequency (step -126)	step
			3	LED Frequency (step -125)	step
			4	LED Frequency (step -124)	step
			:		
			125	LED Frequency (step -3)	step
			126	LED Frequency (step -2)	step
			127	LED Frequency (step -1)	step
			128	Selected LED Frequency (128=default)	step
			129	LED Frequency (step +1)	step
			130	LED Frequency (step +2)	step
			131	LED Frequency (step +3)	step
			:		
			252	LED Frequency (step +124)	step
			253	LED Frequency (step +125)	step
			254	LED Frequency (step +126)	step
			255	Selected LED Frequency	step
9	7	9		Colour functions Factory display menu setting: Colour mixing mode-CMY, Dimmer Curve-Square Law, Tungsten effect simulation-Off, Chromatic white-Off, Light output stability-Off, Uniformity-Off	
			0	No function (0=default) <i>To activate following functions, stop in DMX value for at least 3 seconds. Corresponding menu items are temporarily overridden</i>	step
			1-39	Reserved	
			40-44	Colour mixing mode: CMY (DMX Mode 1 and 2 only)	step
			45-49	Colour mixing mode: RGB (DMX mode 1 and 2), RGBAL (DMX mode 3 only)	step
			50-54	Dimmer curve: Square law	step
			55-59	Dimmer curve: Linear	step
			60-79	Raw DMX	proportional
				<i>Tungsten effect simulation for whites 2700K-4200K only:</i>	
			80-84	Tungsten effect simulation (750W/80V): On	step
			85-89	Tungsten effect simulation (1000W/240V): On	step
			90-94	Tungsten effect simulation (1200W/240V): On	step
			95-99	Tungsten effect simulation (2000W/230V): On	step
			100-104	Tungsten effect simulation (2500W/230V): On	step
			105-109	Tungsten effect simulation: Off	step
			110-114	Save user colour	step
			115-119	Chromatic white: On	step
			120-124	Chromatic white: Off	step
			125-129	Light output stability On	step
			130-134	Light output stability Off	step

DMX protocol

Mode/channel			DMX Value	Function	Type of control
1	2	3			
			135-139	Uniformity On	step
			140-144	Uniformity Off	step
			145-149	Green correction - 2700K/CRI 80	step
			150-154	Green correction - 3200K/CRI 80	step
			155-159	Green correction - 4200K/CRI 80	step
			160-164	Green correction - 5600K/CRI 80	step
			165-169	Green correction - 8000K/CRI 80	step
			170-174	Green correction - 2700K/CRI 90	step
			175-179	Green correction - 3200K/CRI 90	step
			180-184	Green correction - 4200K/CRI 90	step
			185-189	Green correction - 5600K/CRI 90	step
			190-194	Green correction - 8000K/CRI 90	step
			195-199	Save Green correction	step
			200-255	Reserved	
10	8	10		CRI selection	
			0-255	CRI selection from Standard (80) to High (90+) (0=default)	proportional
11	*	11		Virtual colour wheel	
			0	No function (0=default)	step
			1-2	Filter 4 (Medium Bastard Amber)	step
			3-4	Filter 10 (Medium Yellow)	step
			5-6	Filter 19 (Fire)	step
			7-8	Filter 26 (Bright Red)	step
			9-10	Filter 58 (Lavender)	step
			11-12	Filter 68 (Sky Blue)	step
			13-14	Filter 71 (Tokyo Blue)	step
			15-16	Filter 79 (Just Blue)	step
			17-18	Filter 88 (Lime Green)	step
			19-20	Filter 90 (Dark Yellow Green)	step
			21-22	Filter 100 (Spring Yellow)	step
			23-24	Filter 101 (Yellow)	step
			25-26	Filter 102 (Light Amber)	step
			27-28	Filter 103 (Straw)	step
			29-30	Filter 104 (Deep Amber)	step
			31-32	Filter 105 (Orange)	step
			33-34	Filter 106 (Primary Red)	step
			35-36	Filter 111 (Dark Pink)	step
			37-38	Filter 115 (Peacock Blue)	step
			39-40	Filter 116 (Medium Blue-Green)	step
			41-42	Filter 117 (Steel Blue)	step
			43-44	Filter 118 (Light Blue)	step
			45-46	Filter 119 (Dark Blue)	step
			47-48	Filter 120 (Deep Blue)	step
			49-50	Filter 121 (Filter Green)	step
			51-52	Filter 128 (Bright Pink)	step
			53-54	Filter 131 (Marine Blue)	step
			55-56	Filter 132 (Medium Blue)	step
			57-58	Filter 134 (Golden Amber)	step
			59-60	Filter 135 (Deep Golden Amber)	step

DMX protocol

Mode/channel			DMX Value	Function	Type of control
1	2	3			
			61-62	Filter 136 (Pale Lavender)	step
			63-64	Filter 137 (Special Lavender)	step
			65-66	Filter 138 (Pale Green)	step
			67-68	Filter 139 (Primary Green)	step
			69-70	Filter 141 (Bright Blue)	step
			71-72	Filter 147 (Apricot)	step
			73-74	Filter 148 (Bright Rose)	step
			75-76	Filter 152 (Pale Gold)	step
			77-78	Filter 154 (Pale Rose)	step
			79-80	Filter 157 (Pink)	step
			81-82	Filter 158 (Deep Orange)	step
			83-84	Filter 162 (Bastard Amber)	step
			85-86	Filter 164 (Flame Red)	step
			87-88	Filter 165 (Daylight Blue)	step
			89-90	Filter 169 (Lilac Tint)	step
			91-92	Filter 170 (Deep Lavender)	step
			93-94	Filter 172 (Lagoon Blue)	step
			95-96	Filter 179 (Chrome Orange)	step
			97-98	Filter 180 (Dark Lavender)	step
			99-100	Filter 181 (Congo Blue)	step
			101-102	Filter 197 (Alice Blue)	step
			103-104	Filter 201 (Full C.T. Blue)	step
			105-106	Filter 202 (Half C.T. Blue)	step
			107-108	Filter 203 (Quarter C.T. Blue)	step
			109-110	Filter 204 (Full C.T. Orange)	step
			111-112	Filter 205 (Half C.T. Orange)	step
			113-114	Filter 206 (Quarter C.T. Orange)	step
			115-116	Filter 247 (Filter Minus Green)	step
			117-118	Filter 248 (Half Minus Green)	step
			119-120	Filter 281 (Three Quarter C.T. Blue)	step
			121-122	Filter 285 (Three Quarter C.T. Orange)	step
			123-124	Filter 352 (Glacier Blue)	step
			125-126	Filter 353 (Lighter Blue)	step
			127-128	Filter 715 (Cabana Blue)	step
			129-130	Filter 778 (Millennium Gold)	step
			131-132	Filter 793 (Vanity Fair)	step
				<i>The following 70 multicolours are intended for using with prisma, rot. gobo, or effect wheel only. If none of the three effects is used, the colours wil not create multicolour effect.</i>	
			133	Multicolour 1	step
			134	Multicolour 2	step
			135	Multicolour 3	step
			136	Multicolour 4	step
			137	Multicolour 5	step
			138	Multicolour 6	step
			139	Multicolour 7	step
			140	Multicolour 8	step
			141	Multicolour 9	step

DMX protocol

Mode/channel			DMX Value	Function	Type of control
1	2	3			
			142	Multicolour 10	step
			143	Multicolour 11	step
			144	Multicolour 12	step
			145	Multicolour 13	step
			146	Multicolour 14	step
			147	Multicolour 15	step
			148	Multicolour 16	step
			149	Multicolour 17	step
			150	Multicolour 18	step
			151	Multicolour 19	step
			152	Multicolour 20	step
			153	Multicolour 21	step
			154	Multicolour 22	step
			155	Multicolour 23	step
			156	Multicolour 24	step
			157	Multicolour 25	step
			158	Multicolour 26	step
			159	Multicolour 27	step
			160	Multicolour 28	step
			161	Multicolour 29	step
			162	Multicolour 30	step
			163	Multicolour 31	step
			164	Multicolour 32	step
			165	Multicolour 33	step
			166	Multicolour 34	step
			167	Multicolour 35	step
			168	Multicolour 36	step
			169	Multicolour 37	step
			170	Multicolour 38	step
			171	Multicolour 39	step
			172	Multicolour 40	step
			173	Multicolour 41	step
			174	Multicolour 42	step
			175	Multicolour 43	step
			176	Multicolour 44	step
			177	Multicolour 45	step
			178	Multicolour 46	step
			179	Multicolour 47	step
			180	Multicolour 48	step
			181	Multicolour 49	step
			182	Multicolour 50	step
			183	Multicolour 51	step
			184	Multicolour 52	step
			185	Multicolour 53	step
			186	Multicolour 54	step
			187	Multicolour 55	step
			188	Multicolour 56	step
			189	Multicolour 57	step

DMX protocol

Mode/channel			DMX Value	Function	Type of control
1	2	3			
			190	Multicolour 58	step
			191	Multicolour 59	step
			192	Multicolour 60	step
			193	Multicolour 61	step
			194	Multicolour 62	step
			195	Multicolour 63	step
			196	Multicolour 64	step
			197	Multicolour 65	step
			198	Multicolour 66	step
			199	Multicolour 67	step
			200	Multicolour 68	step
			201	Multicolour 69	step
			202	Multicolour 70	step
			203-215	Reserved	
			216-217	User colour 1	step
			218-219	User colour 2	step
			220-221	User colour 3	step
			222-223	User colour 4	step
			224-225	User colour 5	step
			226-227	User colour 6	step
			228-229	User colour 7	step
			230-231	User colour 8	step
			232-233	User colour 9	step
			234-235	User colour 10	step
			236-245	Rainbow effect (with fade time) from slow-> fast	proportional
			246-255	Rainbow effect (without fade time) from slow-> fast	proportional
12	9	*		Cyan/Red (8 bit)	
			0 - 255	Colour saturation control - coarse 0-100% (0=default for CMY mode, 255=default for RGB mode)	proportional
13	*	*		Cyan/Red (16 bit)	
			0 - 255	Colour saturation control - fine (0=default for CMY mode, 255=default for RGB mode)	proportional
14	10	*		Magenta/Green (8 bit)	
			0 - 255	Colour saturation control - coarse 0-100% (0=default for CMY mode, 255=default for RGB mode)	proportional
15	*	*		Magenta/Green (16 bit)	
			0 - 255	Colour saturation control - fine (0=default for CMY mode, 255=default for RGB mode)	proportional
16	11	*		Yellow/Blue (8 bit)	
			0 - 255	Colour saturation control - coarse 0-100% (0=default for CMY mode, 255=default for RGB mode)	proportional
17	*	*		Yellow/Blue (16 bit)	
			0 - 255	Colour saturation control - fine (0=default for CMY mode, 255=default for RGB mode)	proportional
*	*	12		Red (8 bit)	
			0 - 255	Colour saturation control - coarse 0-100% (255=default)	proportional
*	*	13		Red (16bit)	
			0 - 255	Colour saturation control - fine (255=default)	proportional
*	*	14		Green (8 bit)	

DMX protocol

Mode/channel			DMX Value	Function	Type of control
1	2	3			
			0 - 255	Colour saturation control - coarse 0-100% (255=default)	proportional
*	*	15		Green (16bit)	
			0 - 255	Colour saturation control - fine (255=default)	proportional
*	*	16		Blue (8 bit)	
			0 - 255	Colour saturation control - coarse 0-100% (255=default)	proportional
*	*	17		Blue (16bit)	
			0 - 255	Colour saturation control - fine (255=default)	proportional
*	*	18		Amber (8 bit)	
			0 - 255	Colour saturation control - coarse 0-100% (255=default)	proportional
*	*	19		Amber (16bit)	
			0 - 255	Colour saturation control - fine (255=default)	proportional
*	*	20		Lime (8 bit)	
			0 - 255	Colour saturation control - coarse 0-100% (255=default)	proportional
*	*	21		Lime (16bit)	
			0 - 255	colour saturation control - fine (255=default)	proportional
18	12	22		CTC	
			0-1	8000 K	step
			2-64	Colour temperature changing 7978 K ->6622 K (22 K /1 DMX)	proportional
			65	6600 K	step
			66-109	Colour temperature changing 6578 K ->5622 K (22 K/1 DMX)	proportional
			110	5600 K (110=default)	step
			111-179	Colour temperature changing 5580 K ->4220 K (20 K/1 DMX)	proportional
			180	4200 K	step
			181-229	Colour temperature changing 4180 K ->3220 K (20 K/1 DMX)	proportional
			230	3200 K	step
			231-254	Colour temperature changing 3180 K ->2720 K (20K /1 DMX)	proportional
			255	2700K	step
19	*	23		Green correction	
			0	Uncorrected white	step
			1-127	Minus green --> uncorrected white	proportional
			128	Uncorrected white (128=default)	step
			129-254	Uncorrected white --> Plus green	proportional
			255	Uncorrected white	step
20	*	24		Colour mix control	
				<i>Defines relation between Virtual Colour wheel and colour channels</i>	
				"Virtual" = Virtual Colour Wheel	
				"Colour mix" = Colour channels (CMY/RGBALime/CTO)	
			0-9	"Virtual " has priority over "Colour mix" (0=default)	
			10-19	Maximum mode (highest values have priority)	step
			20-29	Minimum mode (lowest values have priority)	step
			30-39	Multiply mode (multiply "Virtual" and "Colour mix")	step
			40-49	Addition mode ("Virtual" + "Colour mix")	step
			50-59	Subtraction mode ("Virtual" - "Colour mix")	step
			60-69	Inverted Subtraction mode ("Colour mix"- "Virtual")	step
			70-79	White Point Off (CTC+Green Cor.+Virtual Colour Wheel deactivated)	step
			80-128	Reserved	
			129	Crossfade "Virtual" only	step
			130-254	Crossfade between "Virtual" and "Colour mix"	proportional

DMX protocol

Mode/channel			DMX Value	Function	Type of control
1	2	3			
			255	Crossfade "Colour mix" only	step
21	*	25		Speed of rot. Gobo selection	
			0-255	Speed of rot. gobo selection from max. to min. (0=default)	proportional
22	*	26		Rot. Gobo carousel/ Framing shutters/Zoom/Focus/Iris/Frost/Prism time	
			0	Function is off (0=default)	step
			1-255	Time of rot. Gobo carousel movement (0.1 sec-->25.5 sec.)	proportional
			1 - 255	Time of framing shutters, zoom, focus, iris and frost movement (0.1 sec-->25.5 sec.)	proportional
			1-50	Time of prism movement (0.1 sec-->5 sec.)	proportional
23	13	27		Effect wheel positioning	
			0-19	No function (0=default)	step
			20-127	Proportional indexing (73-center)	proportional
			128-170	Ramping from open to full position (max-->min. speed)	proportional
			171-213	Ramping from open to half position (max. --->min. speed)	proportional
			214-255	Ramp. from half position to full position (max. --->min. speed)	proportional
24	14	28		Effect wheel rotation	
			0	No rotation	step
			1 - 127	Eff. Wheel rotation from fast to slow CCW (counterclockwise)**	proportional
			128	No rotation (128=default)	step
			129 - 255	Eff. Wheel rotation from slow to fast - CW (clockwise)**	proportional
25	*	29		Effect wheel animations	
			0-7	No animation (0=default)	
				<i>Note : Set suitable DMX value at Focus channel to get desired animation. All animations were created at distance of 5 m from screen with zoom=88 DMX, Focus value is different for each effect (focus value is stated in parentheses for this distance)</i>	
				<i>The following channels are blocked: Effect wheel positioning, Effect wheel rotation, Rotating gobo wheel, Rot. Gobo indexing and rotation.</i>	
			8-9	Macro 1 (Focus=94)	step
			10-11	Macro 2 (Focus=84)	step
			12-13	Macro 3 (Focus=87)	step
			14-15	Macro 4 (Focus=69)	step
			16-17	Macro 5 (Focus=82)	step
			18-19	Macro 6 (Focus=82)	step
			20-21	Macro 7 (Focus=72)	step
			22-23	Macro 8 (Focus=86)	step
			24-25	Macro 9 (Focus=78)	step
			26-27	Macro 10 (Focus=102)	step
			28-255	Reserved	
26	15	30		Rotating gobo wheel	
				<i>Index - set indexing on channel 27/16/31</i>	
			0-3	Open/hole (0=default)	step
			4-7	Gobo 1	step
			8-11	Gobo 2	step
			12-15	Gobo 3	step
			16-19	Gobo 4	step
			20-23	Gobo 5	step
			24-27	Gobo 6	step

DMX protocol

Mode/channel			DMX Value	Function	Type of control
1	2	3			
			28-31	Gobo 7 <i>Rotation - set rotation on channel 27/16/31</i>	step
			32-35	Gobo 1	step
			36-39	Gobo 2	step
			40-43	Gobo 3	step
			44-47	Gobo 4	step
			48-51	Gobo 5	step
			52-55	Gobo 6	step
			56-59	Gobo 7	step
				<i>Shaking gobos from slow to fast</i>	
				<i>Index - set indexing on channel 27/16/31</i>	
			60 - 69	Gobo 1	proportional
			70 - 79	Gobo 2	proportional
			80 - 89	Gobo 3	proportional
			90 - 99	Gobo 4	proportional
			100 - 109	Gobo 5	proportional
			110 - 119	Gobo 6	proportional
			120 - 129	Gobo 7	proportional
				<i>Shaking gobos from slow to fast</i>	
				<i>Rotation - set rotation on channel 27/16/31</i>	
			130 - 139	Gobo 1	proportional
			140 - 149	Gobo 2	proportional
			150 - 159	Gobo 3	proportional
			160 - 169	Gobo 4	proportional
			170 - 179	Gobo 5	proportional
			180 - 189	Gobo 6	proportional
			190 - 199	Gobo 7	proportional
			200 - 201	Open/hole	step
			202 - 222	Forwards gobo wheel rotation from fast to slow	proportional
			223 - 243	Backwards gobo wheel rotation from slow to fast	proportional
			244 - 249	Random gobo selection by audio control <i>(Set microphone sensitivity in menu „Personality“)</i>	step
			250 - 255	Auto random gobo selection from fast to slow	proportional
27	16	31		Rot. gobo indexing and rotation	
				<i>Gobo indexing - set position on channel 26/15/30</i>	
			0 - 255	Gobo indexing (128=default)	proportional
				<i>Gobo rotation - set position on channel 26/15/30</i>	
			0	No rotation	step
			1 - 127	Gobo rotation from fast to slow - CW (clockwise)**	proportional
			128	No rotation (128=default)	step
			129 - 255	Gobo rotation from slow to fast - CCW (counterclockwise)**	proportional
28	*	32		Rot. gobo indexing/rotation - fine	
			0-255	Fine indexing/rotation (0=default)	proportional
29	17	33		Prism (6-facet 8°)	
			0 - 19	Open position - hole (0=default)	step
			20 - 73	Prism indexing	step
			74 -127	Prism rotation	step
				Prism/gobo macros	

DMX protocol

Mode/channel			DMX Value	Function	Type of control
1	2	3			
				<i>The following channels are blocked: Prism, Prism rotation, Rotating gobo wheel, Rot. Gobo indexing and rotation.</i>	
			128 - 135	Macro 1	step
			136 - 143	Macro 2	step
			144 - 151	Macro 3	step
			152 - 159	Macro 4	step
			160 - 167	Macro 5	step
			168 - 175	Macro 6	step
			176 - 183	Macro 7	step
			184 - 191	Macro 8	step
			192 - 199	Macro 9	step
			200 - 207	Macro 10	step
			208 - 215	Macro 11	step
			216 - 223	Macro 12	step
			224 - 231	Macro 13	step
			232 - 239	Macro 14	step
			240 - 247	Macro 15	step
			248 - 255	Macro 16	step
30	18	34		Prism indexing/rotation	
				<i>Prism indexing - set position on channel 29/17/33</i>	
			0 - 255	Prism indexing	proportional
				<i>Prism rotation - set position on channel 29/17/33</i>	
			0	No rotation	step
			1 - 127	Prism rotation from fast to slow - CCW (counterclockwise)**	proportional
			128	No rotation (128=default)	step
			129-255	Prism rotation from slow to fast - CW (clockwise)**	proportional
31	19	35		Frost	
			0	Open (0=default)	step
				<i>Light Frost</i>	
			1-50	Light Frost from 0% to 100%	proportional
			51-53	100% Light Frost	step
			54-63	Pulse closing from slow to fast	proportional
			64-73	Pulse opening from fast to slow	proportional
			74-83	Ramping from fast to slow	proportional
			84-86	Open	step
				<i>Medium Frost</i>	
			87-136	Medium Frost from 0% to 100%	proportional
			137-139	100% Medium Frost	step
			140-149	Pulse closing from slow to fast	proportional
			150-159	Pulse opening from fast to slow	proportional
			160-169	Ramping from fast to slow	proportional
			170-172	Open	step
				<i>Combined Frost</i>	
			173-222	Medium Frost from 0% to 100% (Light Frost inserted)	proportional
			223-225	100% Medium Frost (Light Frost inserted)	step
			226-235	Pulse closing from slow to fast	proportional
			236-245	Pulse opening from fast to slow	proportional
			246-255	Ramping from fast to slow	proportional

DMX protocol

Mode/channel			DMX Value	Function	Type of control
1	2	3			
32	20	36		Iris	
			0	Open (0=default)	step
			1 - 179	From max.diameter to min.diameter	proportional
			180 - 191	Closed	step
				<i>Pulse effects with Iris blackout</i>	
			192 -219	Pulse opening from slow to fast	proportional
			220 - 247	Pulse closing from fast to slow	proportional
			248 - 249	Random pulse opening (fast)	step
			250 - 251	Random pulse opening (slow)	step
			252 - 253	Random pulse closing (fast)	step
254 - 255	Random pulse closing (slow)	step			
33	*	37		Iris - fine	
			0 - 255	Fine iris movement (0=default)	proportional
34	21	38		Zoom	
			0 - 255	Zoom from max. to min.beam angle (128=default)	proportional
35	*	39		Zoom - fine	
			0-255	Fine zooming (0=default)	proportional
36	22	40		Focus	
			0 - 255	Continuous adjustment from far to near (128=default)	proportional
37	*	41		Focus - fine	
			0- 255	Fine focusing (0=default)	proportional
38	23	42		Framing shutters module rotation	
			0-127	Rotation from right (0°) to 60°	proportional
			128	Center (128=default)	step
			129-255	Rotation from 60° to left (120°)	proportional
39	24	43		Framing shutter 1- movement	
			0-255	Movement from Outward to Inward (0=default)	proportional
40	25	44		Framing shutter 1- swivelling	
			0-127	Swivelling from -30 degrees towards 0 degrees	proportional
			128	0 degrees (128=default)	step
			129-255	Swivelling from 0 degrees to +30 degrees	proportional
41	26	45		Framing shutter 2- movement	
			0-255	Movement from Outward to Inward (0=default)	proportional
42	27	46		Framing shutter 2- swivelling	
			0-127	Swivelling from -30 degrees towards 0 degrees	proportional
			128	0 degrees (128=default)	step
			129-255	Swivelling from 0 degrees to +30 degrees	proportional
43	28	47		Framing shutter 3 movement	
			0-255	Movement from Outward to Inward (0=default)	proportional
44	29	48		Framing shutter 3- swivelling	
			0-127	Swivelling from -30 degrees towards 0 degrees	proportional
			128	0 degrees (128=default)	step
			129-255	Swivelling from 0 degrees to +30 degrees	proportional
45	30	49		Framing shutter 4 movement	
			0-255	Movement from Outward to Inward (0=default)	proportional
46	31	50		Framing shutter 4- swivelling	
			0-127	Swivelling from -30 degrees towards 0 degrees	proportional
			128	0 degrees (128=default)	step

DMX protocol

Mode/channel			DMX Value	Function	Type of control
1	2	3			
			129-255	Swivelling from 0 degrees to +30 degrees	proportional
47	32	51		Shutter/ strobe	
			0 - 31	Shutter closed	step
			32 - 63	Shutter open (32=default)	step
			64 - 95	Strobe-effect from slow to fast	proportional
			96 - 127	Shutter open	step
			128 - 143	Opening pulse in sequences from slow to fast	proportional
			144 - 159	Closing pulse in sequences from fast to slow	proportional
			160 - 191	Shutter open	step
			192 - 223	Random strobe-effect from slow to fast	proportional
			224 - 255	Shutter open	step
48	33	52		Dimmer intensity	
			0 - 255	Dimmer intensity from 0% to 100% (0=default)	proportional
49	*	53		Dimmer intensity - fine	
			0 - 255	Fine dimming (0=default)	proportional
** CW and CCW rotation is determined from the perspective of the fixture's mounting point, looking along the projected beam's direction					
Copyright © 2024-2025 Robe Lighting s.r.o. - All rights reserved					
All Specifications subject to change without notice					