

BT-THEATRE 250EZ

06016

DESCRIPTION

Extremely powerful 250 Watt LED theater spot with electronic 10°-50° zoom.

FEATURES

- Extremely powerful LED theater spot with electronic 10° ~ 50° zoom.
- The incredible light output easily outperforms traditional 2KW halogen theatre projectors!!!
- 250watt LED, warm white 3200K with high CRI-factor (>92) for natural colors.
- Color frame for use of color filters and four-leaf barndoor included
- No more heavy and expensive dimmer packs needed!
- Very silent operation: temperature controlled, low noise cooling fan
- LCD-display to navigate easily through the setup menu!
- DMX-controlled: 6 different channel modes (8bit and 16bit dimming) for maximum flexibility.
- Flicker free TV-recordings thanks to 3.6kHz LED refresh rate!
- Manual dimming & zoom/focus control: for easy alignment of the projectors on the stage.
- The lamp behavior can be continuously adjusted from led to halogen.
- Four dimmer curves: linear, square, inverse square, S-curve
- In case of DMX failure you can choose between blackout and freeze mode.
- RDM-functionality for easy remote setup: DMX addressing, channel mode, ...
- Lock function to avoid unwanted altering of the settings.
- Default factory settings + user settings can be saved/loaded.
- 3 & 5pin DMX in/outputs + Neutrik PowerCON in/outputs for easy daisy chaining.



www.briteq-lighting.com | <https://www.facebook.com/Briteq>

Beglec NV has the right to change products and specifications with and without notice. Major as well as minor changes can be involved. This leaflet can contain errors, therefore we advice to consult your local dealer to ensure that actual features and specifications match your requirements. Copyright © 2015 by BEGLEC NV. All rights reserved.



SPECIFICATIONS

| | |
|---|--------------------------------|
| General : Application | Stage & Rental, Theatre |
| General : Weight (kg) | 6.2 |
| General : Powerinput | AC 100 - 240V, 50/60Hz |
| General : Energy Label | No |
| General : Power consumption W | 250 |
| General : Color | black |
| General : Display | No |
| General : Fixation | optional standard clamp |
| General : IP rating | indoor |
| Control : manual | Yes |
| Control : Master/Slave | Yes |
| Control : DMX M/S | No |
| Control : Standalone | fixed |
| Control : programmable | No |
| Control : upgradable software | No |
| Light : lamp socket | none |
| Light : lamp | LED |
| Light : min. color temperature (K) | 3200 |
| Light : max. color temperature (K) | 3200 |
| Light : CRI | 92 |
| Light : colors | Warm white |
| Light : mix colors | No |
| Light : zoom | Motorized |
| Light : iris | No |
| Light : frost filter | No |
| Light : min. beam angle (°) | 10 |
| Light : max. beam angle (°) | 50 |
| Light : min. refresh rate (kHz) | 1.2 |
| Light : max. refresh rate (kHz) | 1.2 |
| Connections : input | 3 pin XLR, 5 pin XLR, powercon |
| Connections : output | 3 pin XLR, 5 pin XLR, powercon |
| Brand | BRITEQ |
| EANCode | 5420025660167 |
| Discontinued | No |

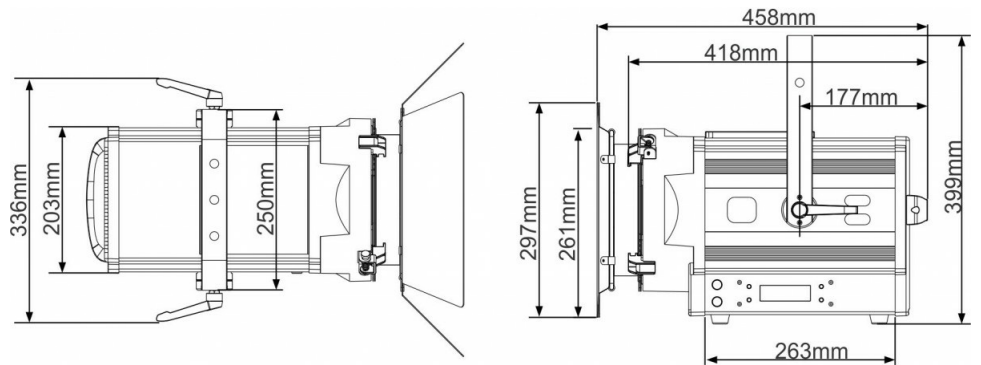
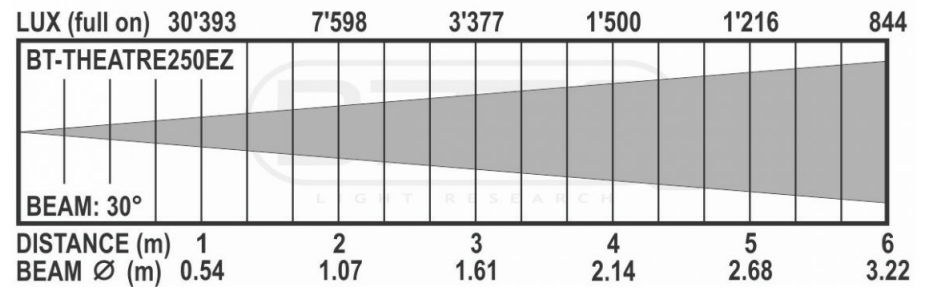
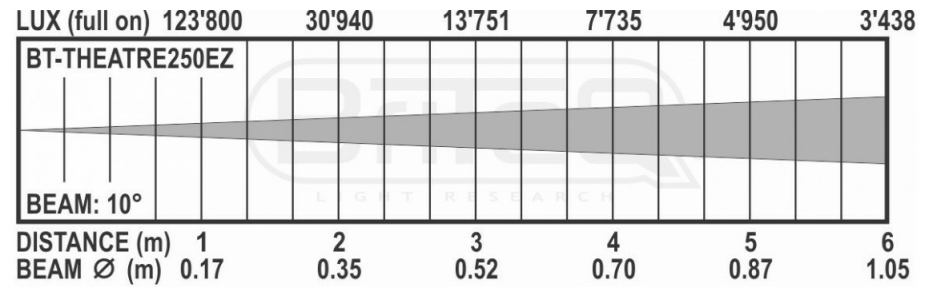

YOUR DEALER



www.briteq-lighting.com | <https://www.facebook.com/Briteq>

Beglec NV has the right to change products and specifications with and without notice. Major as well as minor changes can be involved. This leaflet can contain errors, therefore we advice to consult your local dealer to ensure that actual features and specifications match your requirements. Copyright © 2015 by BEGLEC NV. All rights reserved.