

FX-400

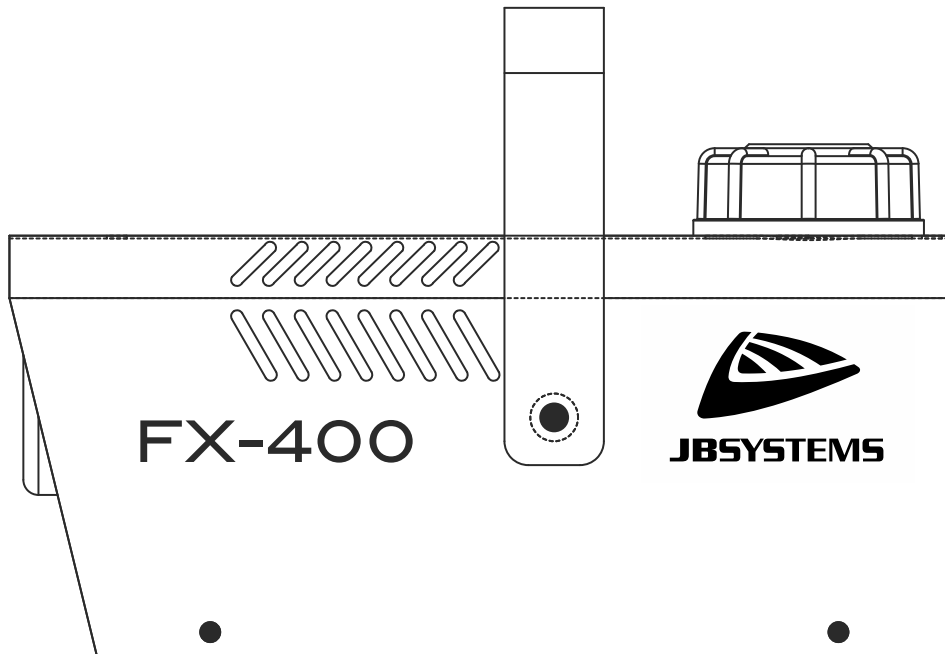

ENGLISH Operation Manual

Other languages can be downloaded from:
WWW.JB-SYSTEMS.EU



Version: 1.0

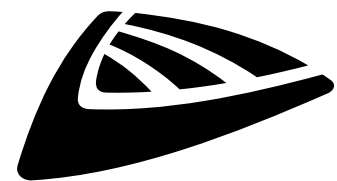

JBSYSTEMS



EN - DISPOSAL OF THE DEVICE

Dispose of the unit and used batteries in an environment friendly manner according to your country regulations.

FR - DÉCLASSER L'APPAREIL

Débarrassez-vous de l'appareil et des piles usagées de manière écologique conformément aux dispositions légales de votre pays.

NL - VERWIJDEREN VAN HET APPARAAT

Verwijder het toestel en de gebruikte batterijen op een milieuvriendelijke manier conform de in uw land geldende voorschriften.

DU - ENTSORGUNG DES GERÄTS

Entsorgen Sie das Gerät und die Batterien auf umweltfreundliche Art und Weise gemäß den Vorschriften Ihres Landes.

ES - DESHACERSE DEL APARATO

Reciclar el aparato y pilas usadas de forma ecologica conforme a las disposiciones legales de su país.

PT - COMO DESFAZER-SE DA UNIDADE

Tente reciclar a unidade e as pilhas usadas respeitando o ambiente e em conformidade com as normas vigentes no seu país.

OPERATION MANUAL

Thank you for buying this JB Systems® product. To take full advantage of all possibilities and for your own safety, please read these operating instructions very carefully before you start using this unit.

FEATURES

- Powerful fogger with amber LED's to color the fog output.
- Perfect for mobile DJs, parties, clubs, home use ...
- Strong fog output
- Manual wired remote control included
- Fog liquid level indicator
- Uses JB Systems "Standard" or "High Tech" fog liquid.

BEFORE USE

- Before you start using this unit, please check if there's no transportation damage. Should there be any, do not use the device and consult your dealer first.
- **Important:** This device left our factory in perfect condition and well packaged. It is absolutely necessary for the user to strictly follow the safety instructions and warnings in this user manual. Any damage caused by mishandling is not subject to warranty. The dealer will not accept responsibility for any resulting defects or problems caused by disregarding this user manual.
- Keep this booklet in a safe place for future consultation. If you sell the fixture, be sure to add this user manual.

Check the contents:

Check that the carton contains the following items:

- Operating instructions
- FX-400 unit
- Hanging bracket + with 2 knobs and 2 rubber rings (put the rings between the bracket and the machine).

SAFETY INSTRUCTIONS:



CAUTION
RISK OF ELECTRIC SHOCK
DO NOT OPEN



CAUTION: To reduce the risk of electric shock, do not remove the top cover. No user-serviceable parts inside. Refer servicing to qualified service personnel only.



The lightning flash with arrowhead symbol within the equilateral triangle is intended to alert the user or the presence of un-insulated "dangerous voltage" within the product's enclosure that may be of sufficient magnitude to constitute a risk of electric shock.



The exclamation point within the equilateral triangle is intended to alert the user to the presence of important operation and maintenance (servicing) instructions in the literature accompanying this appliance.



This symbol means: indoor use only.



This symbol means: Read instructions.



This symbol determines: the minimum distance from objects. The minimum distance between fogger output and objects must be more than 1 meter. NEVER hold your hands close to the fogger output, the fog is very hot and can cause serious burnings !!!

- To protect the environment, please try to recycle the packing material as much as possible.
- To prevent fire or shock hazard, do not expose this appliance to rain or moisture.
- To avoid condensation to be formed inside, allow the unit to adapt to the surrounding temperatures when bringing it into a warm room after transport. Condensation sometimes prevents the unit from working at full performance or may even cause damages.
- This unit is for indoor use only.
- Don't place metal objects or spill liquid inside the unit. Electric shock or malfunction may result. If a foreign object enters the unit, immediately disconnect the mains power.

- Locate the unit in a well ventilated spot, away from any flammable materials and/or liquids.
- Don't cover any ventilation openings as this may result in overheating.
- Prevent use in dusty environments and clean the unit regularly.
- Keep the unit away from children.
- Inexperienced persons should not operate this device.
- Maximum safe ambient temperature is 40°C. Don't use this unit at higher ambient temperatures.
- The units' surface temperature may reach up to 85°C. Don't touch the housing with bare hands during its operation.
- Make sure to always place the unit on a stable surface, never install the fogger above the audience, a little liquid can always drip from the fog output.
- Allow the device about 10 minutes to cool down before you start servicing.
- Always unplug the unit when it is not used for a longer time or before you start servicing.
- Check that the available voltage is not higher than the one stated on the rear panel of the unit.
- The power cord should always be in perfect condition. Switch the unit immediately off when the power cord is squashed or damaged. It must be replaced by the manufacturer, its service agent or similarly qualified persons in order to avoid a hazard.
- Never let the power-cord come into contact with other cables!
- This unit must be earthed in order comply with safety regulations.
- In order to prevent electric shock, do not open the cover.
- **Never** repair a fuse or bypass the fuse holder. **Always** replace a damaged fuse with a fuse of the same type and electrical specifications!
- In the event of serious operating problems, stop using the fixture and contact your dealer immediately.
- The housing must be replaced if they are visibly damaged.
- Please use the original packing when the device is to be transported.
- Due to safety reasons it is prohibited to make unauthorized modifications to the unit.

WARNING: DANGER ! if you want to install the unit in a truss or on the ceiling: Never hang the unit above an area where people might pass. Some hot liquid might drip out of the nozzle. If it hits a person it might cause serious burns !

DESCRIPTION:

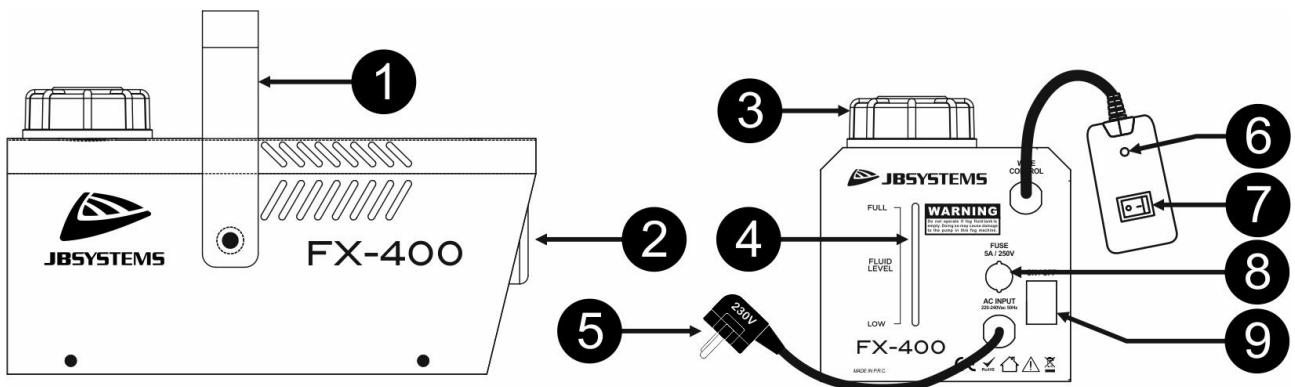

1. **HANGING BRACKET:** hanging bracket with two knobs on both sides to fasten the unit + mounting holes to fix a mounting hook.
2. **NOZZLE:** fog output. **WARNING: HOT!** Keep a minimum distance of 1m.
3. **FOG FLUID CONTAINER:** to be filled with CE-certified smoke fluid. **Make sure that the fog fluid container is never empty during operation, this will damage the pump of the fogger.**
4. **FLUID LEVEL INDICATOR:** indicates how much fog fluid is still available.
5. **MAINS CABLE:** to be plugged in a mains wall socket with earth connection.
6. **HEATER TEMPERATURE LED:** when the LED is lit, the machine is ready to produce fog.
7. **FOG OUTPUT SWITCH:** used to activate/deactivate the fog output
8. **FUSE:** When the fuse is blown, first locate and solve the problem that caused the fuse to blow. When the problem is solved, replace a damaged fuse with a fuse of the same type and electrical specifications.
9. **POWER SWITCH:** used to switch the machine ON/OFF

OPERATING INSTRUCTIONS

- Put the fogger on a flat and very stable surface. Make sure that nobody can put their hands just in front of the output. The fog is very hot and can cause serious burnings!!!
- Make sure the fog liquid tank is not empty. Always use good quality fog liquid to fill up the tank. Close the tank immediately to prevent dirt to enter the reservoir!
- Make sure to plug the fogger in a mains wall socket with earth connection
- Switch the fogger on (9) and wait for about 3 minutes. (warm up time)
- When the LED of the remote control is lit (6) you can use the Fog output switch (7) to activate/deactivate the fog production.

MAINTENANCE

- Switch off the unit, unplug the mains cable and wait until the unit has been cooled down.

During inspection the following points should be checked:

- All screws used for installing the device and any of its parts should be tightly fastened and may not be corroded.
- Housings, fixations and installations spots (ceiling, truss, suspensions) should be totally free from any deformation.
- The mains cables must be in impeccable condition and should be replaced immediately when even a small problem is detected.

Cleaning the fogger:

To prevent obstructions in the heater, pump and tubes, the fogger should be cleaned on a regular basis: every 100h of continuous operation is a good reference.

- Switch the fogger off
- Remove the nozzle (metal part where the fog leaves the fogger)
- Remove the fog liquid from the tank
- Fill the tank with about 1liter of a solution containing 80% distilled water and 20% white vinegar.
- Switch the fogger on and wait for about 8minutes (warm up time)
- Put the fogger in continuous operation mode until the tank is empty
- Put the nozzle back in place
- Remove the eventual residues of the cleaning solution and refill the tank with fog liquid.

Remark: cleaning should be done outside; an awful smell is produced by the vinegar solution!

Attention: We strongly recommend internal cleaning to be carried out by qualified personnel!

SPECIFICATIONS

This unit is radio-interference suppressed. This product meets the requirements of the current European and national guidelines. Conformity has been established and the relevant statements and documents have been deposited by the manufacturer.

This device has been designed to produce decorative effect lighting and is used in light show systems.

Mains Input:	AC 220-240V, 50Hz
Power consumption:	400 Watt
Fuse (size: 5x20mm):	250V / 5A
Warm up time:	2 à 3 min
Tank size:	0,5L
Fluid to be used:	Fog Liquid (JB Systems Standard or HI-Tech)
Fluid consumption:	4 ml/min
LEDs:	3x 3Watt (amber)
Size:	237 x 118 x 163 mm
Weight:	1,8 kg

Every information is subject to change without prior notice

You can download the latest version of this user manual on our website: www.jb-systems.eu



JB SYSTEMS

MAILING LIST

EN: Subscribe today to our mailing list for the latest product news!

FR: Inscrivez-vous à notre liste de distribution si vous souhaitez suivre l'actualité de nos produits!

NL: Abonneer je vandaag nog op onze mailinglijst en ontvang ons laatste product nieuws!

DE: Abonnieren Sie unseren Newsletter und erhalten Sie aktuelle Produktinformationen!

ES: Suscríbete hoy a nuestra lista de correo para recibir las últimas noticias!

PT: Inscreva-se hoje na nossa mailing list para estar a par das últimas notícias!

WWW.JB-SYSTEMS.EU

Copyright © 2018 by BEGLEC NV

t Hofveld 2C ~ B1702 Groot-Bijgaarden ~ Belgium

Reproduction or publication of the content in any manner, without express permission of the publisher, is prohibited.