

1	2
品牌	BOYA 长丰型号 BY-PM7000SP

7	8
修改名称	版本
变更内容	变更日期
变更担当	



**Introduction**

Thanks for purchasing BOYA BY-PM700SP!

The BOYA BY-PM700SP is a USB condenser microphone, and compatible with most of iOS devices, Android devices, Windows and Mac computers.

It features a 1/8" (3.5mm) headphone output, wide frequency response and 24 bit/48 kHz resolution make BOYA BY-PM700SP suitable for Podcasts, voice recognition software, music recording, general speech, etc.

Switchable polar patterns provide cardioid, bi-directional, omnidirectional and stereo pick up patterns to allow you to choose whatever pattern is more appropriate for your specific situation.

This mic has durable all metal construction, includes desk stand that can adjust microphone in various desired angles, also functionality of folding the mic down for storage and transport as well.

**Package Contents**

- BY-PM700SP Microphone
- Lightning Cable
- Type-C Cable
- USB Cable
- User Manual

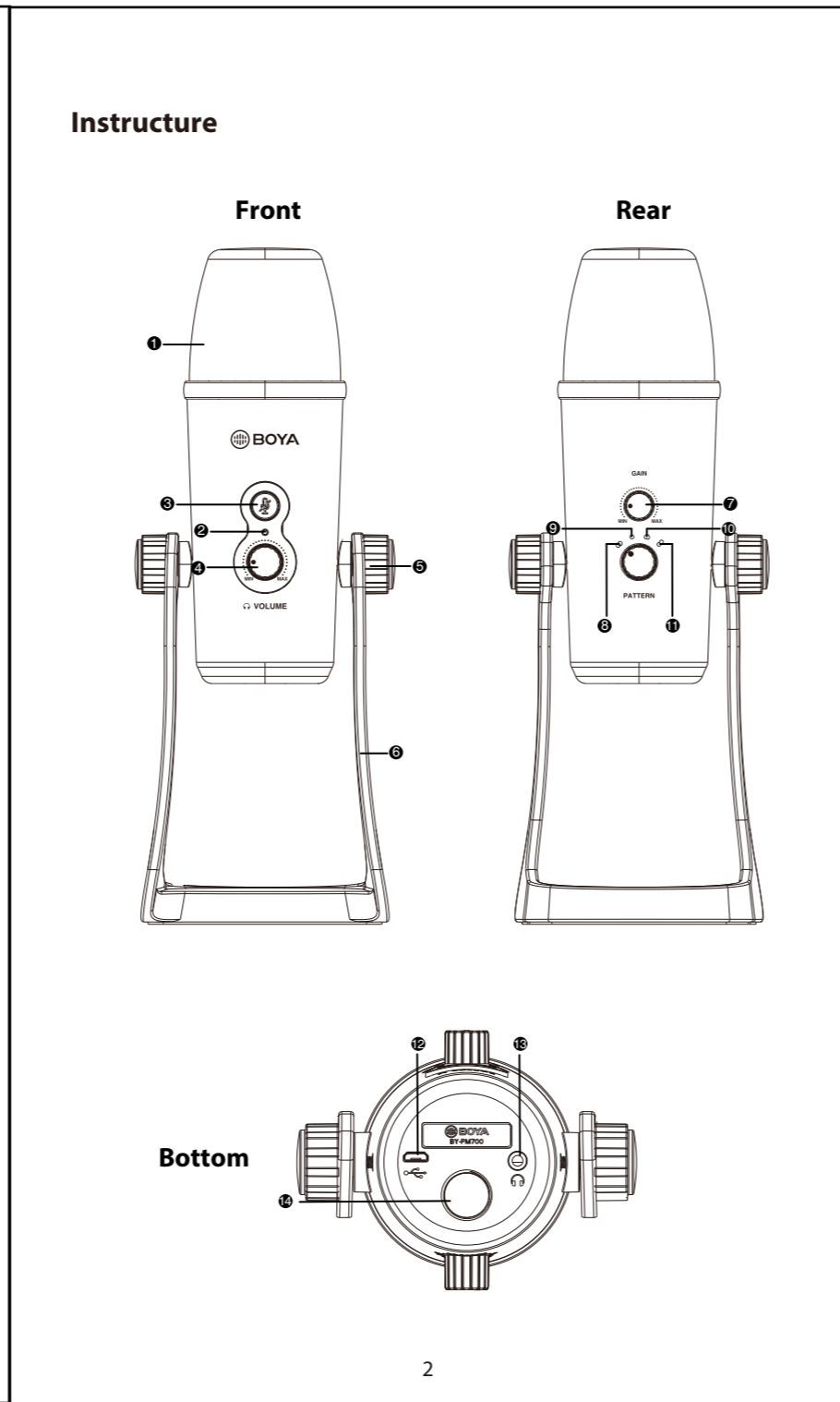

**Introduction**

1. Tri-Capsule Array
2. Power Indicator
3. Mute Button  
Press mute button, when LED indicator is red, muting function on.
4. Headphone Volume Control
5. Screws
6. Desk Stand
7. Microphone Gain
8. Stereo Pattern  
Pick up the sound from left and right side, it is ideal for capturing a realistic, general sound.
9. Cardioid Pattern  
Maximizes the rejection of sound coming from the sides and rear of the mic and can be used as a directional microphone to capture full, rich, natural-sounding audio for podcast, speech, dialog, instrument etc.
10. Omnidirectional Pattern  
Pick up sound equally from all directions, capturing a natural blend of voice and ambiance with low sensitivity to wind and handling noise, as well as to vocal plosives.
11. Bi-directional Pattern  
Pick up sound at the front and rear of the microphone, while sounds to the sides are not picked up, it fits for capturing instruments, or recording an interview between two people.
12. Micro USB
13. Headphone Output
14. 5/8" screw

**Features:**

- For iOS devices, Android devices, Windows and Mac computers
- Triple-capsule design
- 24 bit/48 kHz resolution
- Cardioid, Stereo, Omnidirectional, Bi-directional
- Requires no drivers
- Master volume control
- Microphone gain control
- Mute function
- 3.5mm (1/8") headphone monitoring jack
- Durable all metal construction

**Specifications:**

Diaphragm:	14 mm (0.55")
Acoustic Principle:	Pre-polarized Condenser
Bit Length:	24 Bit
Sample Rates:	48KHz
Frequency Response:	20-20,000Hz
Sensitivity:	-45±3dB (0dB=1V/Pa @ 1KHz)
SN:	80dB
Output Gain:	0-25dB Continuously Adjustable
Output:	Micro USB
Connector:	1) Apple Mfi Certified Lightning 2) Type-C 3) USB-A
Power Consumption:	5V/150mA
Cable Length:	1m(3.3ft)
Size:	112 x 108 x 200mm(4.4 x 3.8 x 7.9")(Min.) 112 x 108 x 295mm(4.4 x 3.8 x 11.6") (Max.)
Weight:	1042g(36.8oz)

**How to use**

1. Unscrew the knobs of both sides at anti-clockwise.
2. Adjust the microphone at your desired angle, then screw the knobs of both sides at anti-clockwise to fix the microphone.
3. Plug the mini USB of supplied cable into the USB port of your computer, and connect the other plug into the available USB port of your computer.
4. Connect your headphone to 3.5mm headphone output if needed.

**Set Up for iOS devices**

1. Using supplied Lightning cable, connects microphone with a Micro USB port.
2. Plug the Lightning connector with your iOS device.
3. The indicator of microphone will stay green when open Video/recording APP from smartphone.
4. Start recording.

**Set Up for Andriod devices**

1. Use supplied Type-c cable and connect microphone with a Micro USB port.
2. Plug the Type-c connector with your Andriod device.
3. The indicator of microphone will stay green when open Video/recording APP from smartphone.
4. Start recording.

**NOTE:**  
Not all Android devices support external microphone when taking video, and you may need to download a third-party app and set up sound source as external microphone.

**Setup for Apple System**

1. Connect the BOYA BY-PM700SP to an un-used USB port on your computer.
2. Go to Apple Icon-->System Preferences-->Sound Icon.

3. Select "BY-PM700SP" under "Input" tab.

4. Select "BY-PM700SP" under "Output" tab.

**Set Up for Windows 10**

1. Connect microphone with a USB port on your computer using the supplied USB cable.
2. Go to "Setting", choose "Sound" as shown below.
3. Select "Speaker BY-PM700SP" as Output device.
4. Select "Microphone BY-PM700SP" as Input device.

**Set Up for Windows 7**

1. Connect microphone with a USB port on your computer using the supplied USB cable.
2. From the "Setting Menu", select the "Control Panel".
3. Go to "Control Panel", select "Hardware and Sound"

4. Select "Sound"

5. Select "Speaker BY-PM700SP" as the default device in the "Sound", under "Playback" manu.

6. Select "Microphone BY-PM700SP" as the default device in the "Sound", under "Recording" manu.

**IMPORTANT**

- If you do not intend to use the conference microphone for a long period time, please remove the USB cable.
- Do not touch the microphone while recording, as this will cause noise to be recorded.
- Do not let the microphone close to high-voltage equipment or to devices that emit strong electromagnetic fields, otherwise, it may cause the noise to be recorded.
- Do not use or leave the microphone in hot, humid places.

**MAINTENANCE**

- Do not operate the device with wet hands or feet.
- Clean the equipment only in the way described in the instructions for use.

www.boyam-mic.com

SHENZHEN JIAYZ PHOTO INDUSTRIAL, LTD.  
The BOYA logo is a trademark which is registered and owned by Shenzhen Jiayz Photo Industrial, Ltd.  
COPY RIGHT 2010-2020  
Email: sales@boyam-mic.com  
www.boyam-mic.com / www.jiayz.com

技术要求:

- 1、表面无色差
- 2、无正负公差
- 3、包装标注尺寸为内尺寸



<b>JIAYZ 长丰</b> 深圳市长丰影像器材有限公司					
子件名称	BY-PM700SP 说明书	版本	V00		
子件编号	1F0300300198	材质	105g双铜纸	骑马钉 12p	
尺寸	120x200	比例	1:1	单位	mm
设计/日期	吴蒙蒙 2019-6-1	审核	暂无	核准/日期	赵宏亮