



CVC4 – Installation Guide

High precision, auto-addressable RGBW LED tape dimmer with P-Link or DMX/RDM input.



ENTTEC's CVC4 is a high precision 4 channel, constant voltage (CV) LED dimmer, capable of dimming up to 5A of LED tape per channel at 12-24v.

The CVC4's key feature is its integration of ENTTEC's Pixelator family controller's auto-addressing PLink protocol. This is a time saving system designed to allow users to simply chain one device to the next using Cat6 cable up to 300m away, removing the need to manually address each CVC4.

Alternatively use RDM to configure the start address of each CVC4 (default channel 001) and control over DMX. Another feature for the CVC4 is its ability to convert DMX to PLink protocol, connect a Cat6 cable to a CVC4 receiving DMX and the PLink protocol will auto-address all consecutive CVC4 along the daisy chain.

The CVC4 incorporates a user-serviceable blade fuse to protect against short circuits and features the ability to limit the output to reduce overheating. With two DIP switches located on the CVC4, easily switch between RGB/RGBW and 8-bit/16-bit modes.

The solid-state, fan-less design means the CVC4 is virtually silent when in operation.

Features

- Dimming capacity of up to 5A per channel
- 12-24V input (20A maximum).
- 1KHz PWM signal refresh rate.
- Daisy Chained, auto-addressing P-Link Protocol over Cat6 cable.
- Single screw terminal for DMX/RDM input.
- Status LED and DIP switch to toggle between RGB/RGBW and 8-bit/16-bit operating modes.
- User-serviceable blade fuse to protect against short circuits.
- Passive cooling with internal overheating protection.
- Compact design with integrated 4mm surface mounting holes.

Content

Safety.....	2
Electrical safety.....	3
System Planning and Specification	3
Protection from Injury During Installation.....	3
Installation Safety Guidelines.....	4
Physical Dimensions.....	4
CVC4 Hardware.....	5
How to specify CVC4's.....	6
Single Channel Tape.....	7
Three Channel RGB Tape	8
Four Channel RGBW Tape.....	9
Maximum tape length: (based on the LED channel with the highest power draw)	9
Application Diagrams	10
Controlling CVC4s using ENTTEC's PLink system.....	10
Controlling CVC4s Using DMX512	11
Controlling CVC4s using DMX512 & RDM.....	12
Updating firmware over RDM using ENTTEC RDM Controller.....	13
Surface mounting the CVC4.....	15
Wiring the CVC4	15
Setting the CVC4's fixture operating mode.....	16
Replacing the user serviceable fuse.....	17
Servicing, Inspection & Maintenance.....	18
Cleaning.....	18
Package Contents	19
Ordering Information	19
.....	19

Safety

 **Ensure you are familiarized with all key information within this guide and other relevant ENTTEC documentation before specifying, installing, or operating an ENTTEC device. If you are in any doubt about system safety, or you plan to install ENTTEC device in a configuration that is not covered within this guide, contact ENTTEC or your ENTTEC supplier for assistance.**

ENTTEC's return to base warranty for this product does not cover damage caused by inappropriate use, application, or modification to the product.

Electrical safety



- This product must be installed in accordance with applicable national and local electrical and construction codes by a person familiar with the construction and operation of the product and the hazards involved. Failure to comply with the following installation instructions may result in death or serious injury.
- Do not exceed the ratings and limitations defined in the product datasheet or this document. Exceeding can cause damage to the device, risk of fire and electrical faults.
- Ensure that no part of the installation is or can be connected to power until all connections and work is complete.
- Before applying power to your installation, ensure your installation follows the guidance within this document. Including checking that all power distribution equipment and cables are in perfect condition and rated for the current requirements of all connected devices and factor in overhead and verify that it is appropriately fused and voltage is compatible.
- Remove power from your installation immediately if accessories power cables or connectors is in any way damaged, defective, shows signs of overheating or are wet.
- Provide a means of locking out power to your installation for system servicing, cleaning and maintenance. Remove power from this product when it is not in use.
- Ensure your installation is protected from short circuits and overcurrent. Loose wires around this device whilst in operation, this could result in short circuiting.
- Do not over stretch cabling to the device's connectors and ensure that cabling does not exert force on the PCB.
- Do not 'hot swap' or 'hot plug' power to the device or its accessories.
- Do not connect any of this devices V- (GND) connectors to earth.
- Do not connect this device to a dimmer pack or mains electricity.
- Install this product on either insulated or electrically earthed surface.

System Planning and Specification



- To contribute to an optimal operating temperature, where possible keep this device out of direct sunlight.
- Any twisted pair, 120ohm, shielded EIA-485 cable is suitable to transmit DMX512 data to or from the DIN ETHERGATE. The DMX cable should be suitable for EIA-485 (RS-485) with one or more low capacitance twisted pairs, with overall braid and foil shielding. Conductors should be 24 AWG (7/0.2) or larger for mechanical strength and to minimize volt drop on long lines.
- A maximum of 32 devices should be used on a DMX line before re-generating the signal using a DMX buffer/ repeater / splitter.
- Always terminate DMX chains using a 120Ohm resistor to stop signal degradation or data bounce-back.
- The maximum recommended DMX cable run is 300m (984ft). ENTTEC advises against running data cabling close to sources of electromagnetic interference (EMF) i.e., mains power cabling / air conditioning units.
- This device has an IP20 rating and is not designed to be exposed to moisture or condensing humidity.
- Ensure this device is operated within the specified ranges within its product datasheet.

Protection from Injury During Installation



- Installation of this product must be performed by qualified personnel. If ever unsure always consult a professional.
- Always work with a plan of the installation that respects all system limitations as defined within this

guide and product datasheet.

- All network cabling should be terminated with an RJ45 connector in accordance with the T-568B standard.
- Always use suitable personal protective equipment when installing ENTTEC products.
- Once installation is completed, check that all hardware and components are securely in place and fastened to supporting structures if applicable.

Installation Safety Guidelines



- The device is convection cooled, ensure it receives sufficient airflow so heat can be dissipated. If the CVC4 overheats its output brightness will be temporarily halved to protect itself and the indicator LED will flash red.
- The device is not designed for inductive loads.
- Do not cover the device with insulating material of any kind.
- Do not operate the device if the ambient temperature exceeds that stated in the device specifications.
- Do not cover or enclose the device without a suitable and proven method of dissipating heat.
- Do not install the device in damp or wet environments.
- Do not modify the device hardware in any way.
- Do not use the device if you see any signs of damage.
- Do not handle the device in an energized state.
- Do not crush or clamp the device during installation.
- Do not sign off a system without ensuring all cabling to the device and accessories has been appropriately restrained, secured and is not under tension.

Physical Dimensions

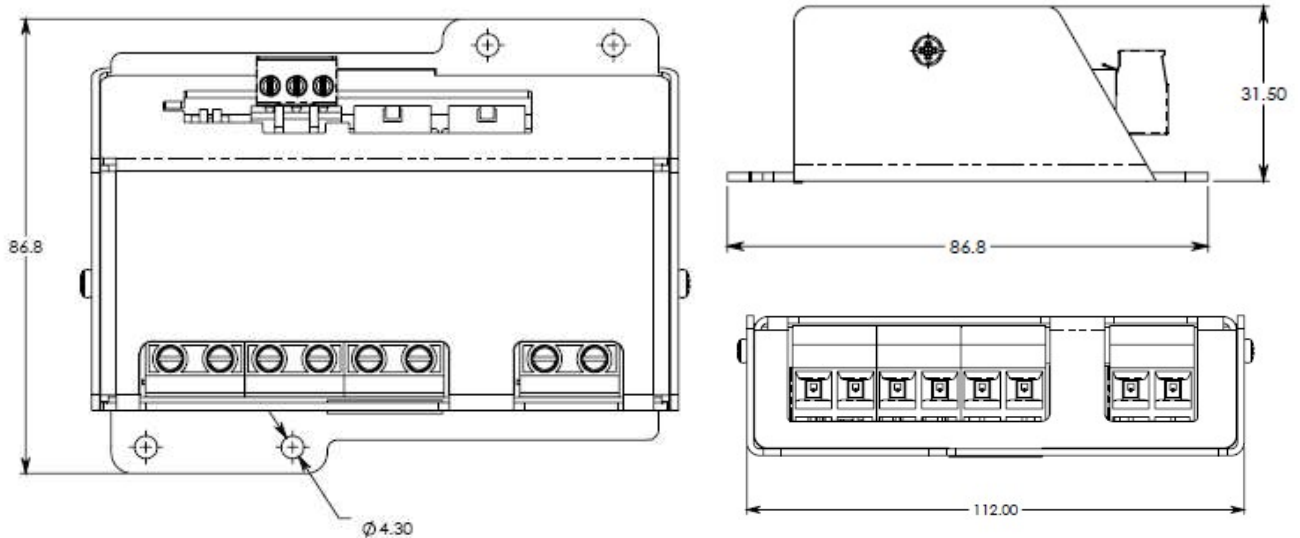

CVC4 Hardware

The CVC4's exterior is constructed from folded aluminium with a powder coated finish.



1	12-24V DC Power Input (20A Max Input)
2	4 Dimmable Channels (5A Per Channel Max)
3	PLink IN / OUT
4	DMX IN
5	Mode Selection DIP-Switch and LED Indicator

Note: If the data source to your CVC4 – (either PLink or DMX) - drops out, whilst the CVC4 still remains powered on (eg. the controller happens to lose power while the rest of the install remains powered) the CVC4 will continue to output to your constant voltage lights based on the last frame of data it received before the dropout.

For example, if your CVC4 had channel 3 set to full intensity before the data dropped out, the CVC4 will continue to output full intensity until the data source comes back online and sends updated data.

How to specify CVC4's

Each CVC4 can dim up to 20A load spread over each of its four 5A output channels.

- It's critical that all cabling and constant voltage power supplies are rated to handle the maximum power required by the system.
- ENTTEC recommends stranded copper cable.

First step of planning an installation is to determine the quantity of LED strip that the CVC4 can control split across its 4 channels in addition to any increased load introduced by voltage drop or cabling.

To do this you will require:

- The Power Draw of each of your LED tape channels (in Watts per meter).
- The Voltage required by your LED tape (in Volts).
- The Percentage Overhead you leave to account for cabling and voltage drop in your system (in the following examples we will factor in 10% for cabling and voltage drop [by multiplying the theoretical total length per CVC4 by 0.9]).

Voltage drop and cable resistance vary based on the LED strip and cabling used for your installation.

Calculation for maximum tape length per CVC4 channel with 10% overhead for voltage drop and cabling factored in:

$$\left(\left(\frac{5 \text{ Amps}}{\left(\frac{\text{Per Channel Power Draw (Watts per Meter)}}{\text{LED Strip Voltage (Volts)}} \right)} \right) * 0.9 \right) = \text{Total Tape Length per Channel (with 10\% overhead)}$$

Note: If using RGB or RGBW tape, no single channel must draw more than 5A. Base the length of tape you use on the channel with the highest power draw.

Warning: The following calculations are representative of the maximum capacity of LED strip that a CVC4 driver can control based on current draw. Always check the datasheet of your LED strip to determine the maximum continuous run length or if any additional considerations are required by its manufacturer.

Single Channel Tape

To determine the total quantity of constant voltage single channel LED tape the CVC4 can control, we need to determine how many meters can be controlled with 20A.

For this example, we will use ENTTEC's 9CH LED tape – this is a high output single channel white led strip capable of 1385 lumens per meter.

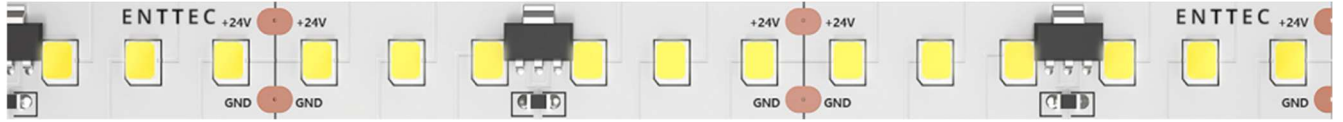

9CM2 Specifications:

Channel	Power Consumption (W/m)	Operational Voltage (V)
White	14.64	24

Maximum tape length per Channel: (with 10% overhead)

$$\left(\left(\frac{5A}{\left(\frac{14.64 W/m}{24V} \right)} \right) * 0.9 \right) = 7.37m \text{ Per Channel}$$

Maximum tape length per Device: (with 10% overhead)

$$(7.37 * 4) = 29.48m \text{ Per CVC4}$$

From these calculations we can see that the maximum tape length per device including the 10% safety factor is **29.48m, the maximum limit of tape used per channel is 7.37m.**

Note: Always, check manufacturer guidance for your selected LED Strip to determine its maximum continuous run length, this is often lower than the maximum amount of strip the CVC4 can control.

Three Channel RGB Tape

To determine the quantity of constant voltage RGB LED tape the CVC4 can control, firstly we need to determine how many meters of the channel with the highest power draw can be controlled with 5A.

For this example, we will use ENTTEC's 9VL4 LED tape – this is a high output 3 channel RGB LED strip.

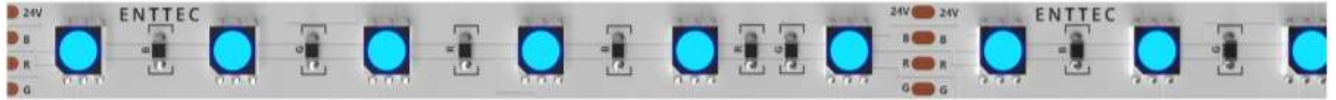

9VL4 Specifications:

Channel	Power Consumption (W/m)	Operational Voltage (V)
Red	4.45	24
Green	3.31	24
Blue	3.12	24

Maximum tape length: (based on the LED channel with the highest power draw)

Red = Channel with the highest power draw.

$$\left(\left(\frac{5A}{\left(\frac{4.45 W/m}{24V} \right)} \right) * 0.9 \right) = 25.00m$$

From this calculation we can determine that the maximum amount of RGB tape that can be controlled per CVC4 including the 10% safety factor is **25.00m**.

	Channel 1	Channel 2	Channel 3	Channel 4
Distance	25.00m	25.00m	25.00m	N/A
Power Draw (+10% Overhead)	5.00A	3.83A	3.61A	N/A

Note: Always, check manufacturer guidance for your selected LED strip to determine its maximum continuous run length, this is often lower than the maximum amount of strip the CVC4 can control.

Four Channel RGBW Tape

To determine the quantity of constant voltage RGBW LED tape the CVC4 can control, firstly we need to determine how many meters of the channel with the highest power draw can be controlled with 5A.

For this example, we will use ENTTEC's 9VLW LED tape – this is a high output 4 channel RGBW LED strip.



9VLW Specifications:

Channel	Power Consumption (W/m)	Operational Voltage (V)
Red	4.45	24
Green	3.31	24
Blue	3.12	24
White	6.4	24

Maximum tape length: (based on the LED channel with the highest power draw)

White = Channel with the highest power draw.

$$\left(\left(\frac{5A}{\left(\frac{6.4W/m}{24V} \right)} \right) * 0.9 \right) = 17.03m$$

From this calculation we can determine that the maximum amount of RGB tape that can be controlled per CVC4 including the 10% safety factor is **17.03m**.

	Channel 1	Channel 2	Channel 3	Channel 4
Distance	17.03m	17.03m	17.03m	17.03m
Power Draw (+10% Overhead)	3.50A	2.60A	2.48A	5.00A

Note: Always, check manufacturer guidance for your selected LED strip to determine its maximum continuous run length, this is often lower than the maximum amount of strip the CVC4 can control.

Application Diagrams

Note: In all applications, if the data source to your CVC4 - whether PLink or DMX - drops out, while the CVC4 still remains powered (e.g. the control system happens to lose power while the rest of the install remains powered on), then the CVC4 will continue to output to your lights based on the last frame of data it received.

For example, if channel 1 was at 50% intensity before the data dropped out, the CVC4 will continue to hold channel 1 at 50% until the data source returns.

Controlling CVC4s using ENTTEC's PLink system

PLink is ENTTEC's proprietary auto addressing protocol used to send data over long distances cost effectively.

PLink signal can be generated from ArtNet, sACN or ESP universes using the following ENTTEC products:

- Pixelator
- Pixelator Mini
- DIN Pixelator Mini

The PLink output of the above products should be linked to the CVC4's input port. DMX start address of the PLink feed can be defined within the devices web interface.

A maximum cable length of 300m can be achieved between each CVC4 whilst using CAT6 cable.

The following diagram depicts all CVC4s set to a 16-Bit RGBW operating mode (8ch Per CVC4):

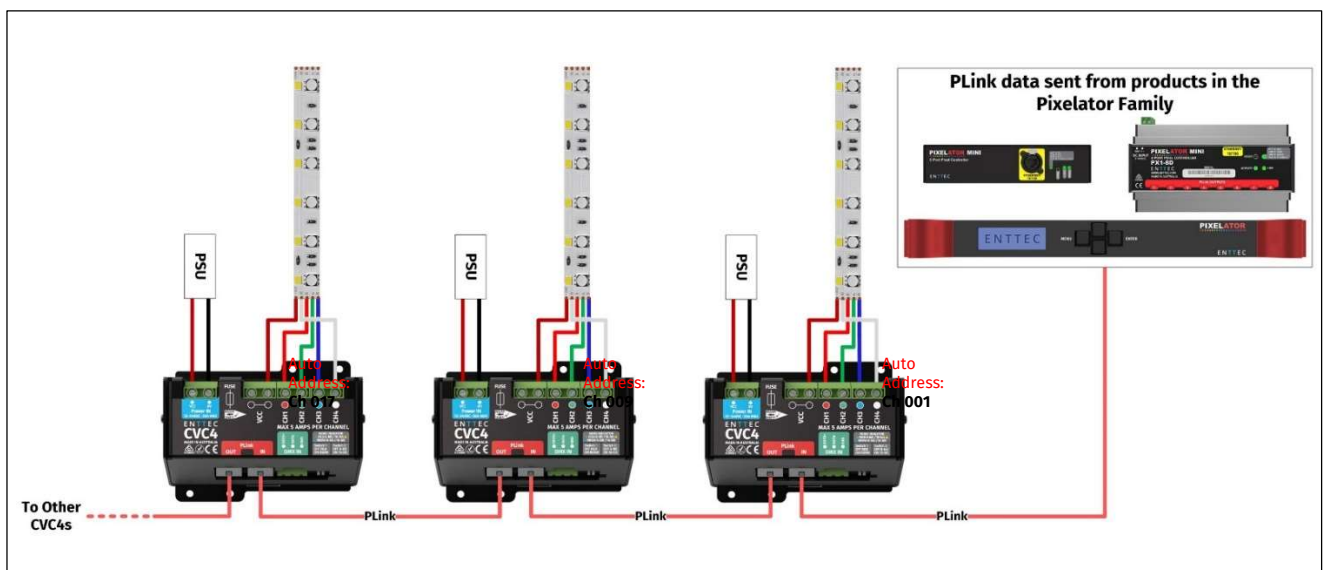

Note: When using CVC4s with any product within the Pixelator Family, set the P-Link port you have connected your CVC4s to output WS2812b with colour ordering RGB. This will convert your input DMX signal 1:1 into P-Link allowing you to mix and match CVC4 operating modes within the same String and patch them within your lighting control software.

Controlling CVC4s Using DMX512

When using DMX512 to control a string of CVC4's. The DMX input should be wired to the 3-pole Phoenix connector of the first CVC4 in the chain – By default, the CVC4 ships set to channel **001**. – This can be modified using any RDM (E1.20) compliant controller device.

Following the first unit, the CVC4's PLink Output should be used to link the remaining devices together using the auto-addressing PLink protocol. A maximum cable length of 300m can be achieved between each CVC4 whilst using CAT6 cable.

If both a DMX and PLink input source are plugged into the same CVC4, DMX always takes priority.

The following diagram depicts all CVC4s set to a 16-Bit RGBW operating mode (8ch Per CVC4):

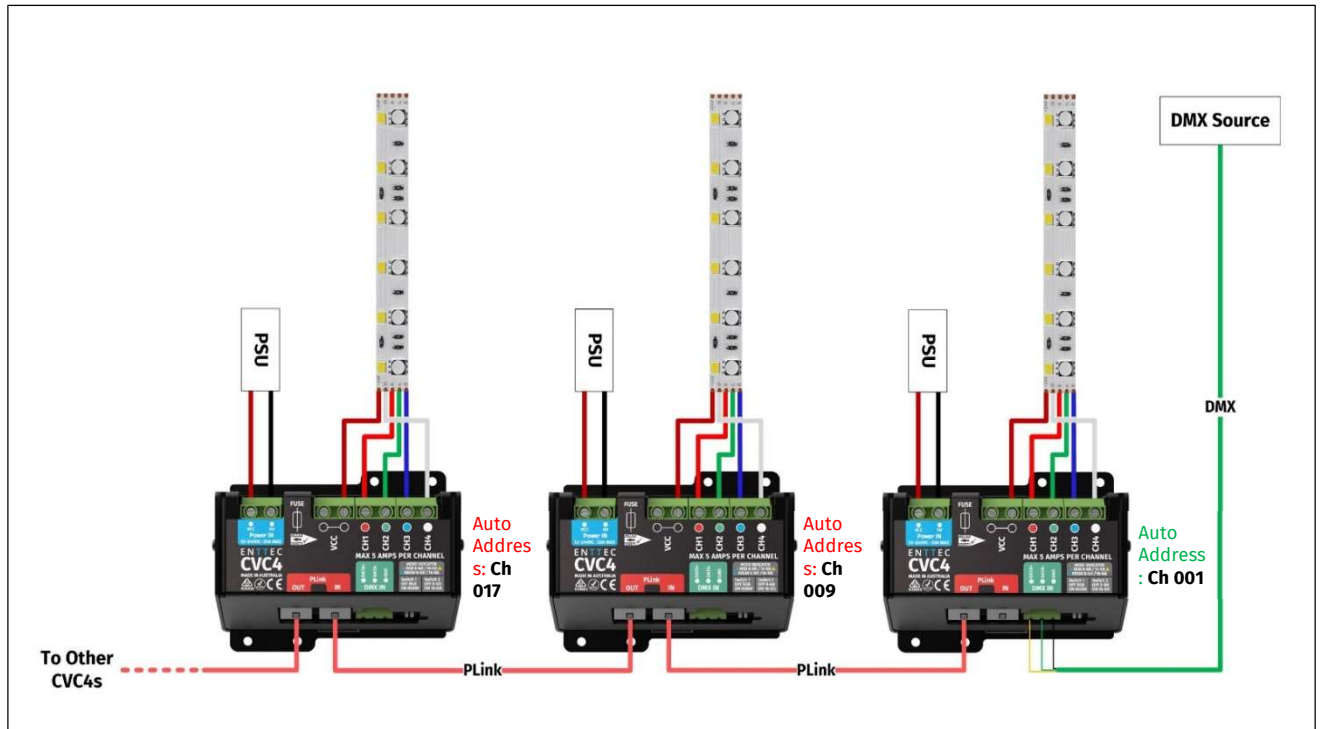

Note: The CVC4 allows for operation mode to be set by DIP Switches only – Not via RDM.

Controlling CVC4s using DMX512 & RDM

RDM can be used to address, identify and update the firmware of CVC4's.

If using RDM, a DMX feed can be linked between CVC4's and the DMX start address configured using RDM for each CVC4.

If both a DMX and PLink input source are plugged into the same CVC4, DMX always takes priority.

The following diagram depicts all CVC4s set to a 16-Bit RGBW operating mode (8ch Per CVC4):

Note: The CVC4 allows for operation mode to be set by DIP Switches only – Not via RDM

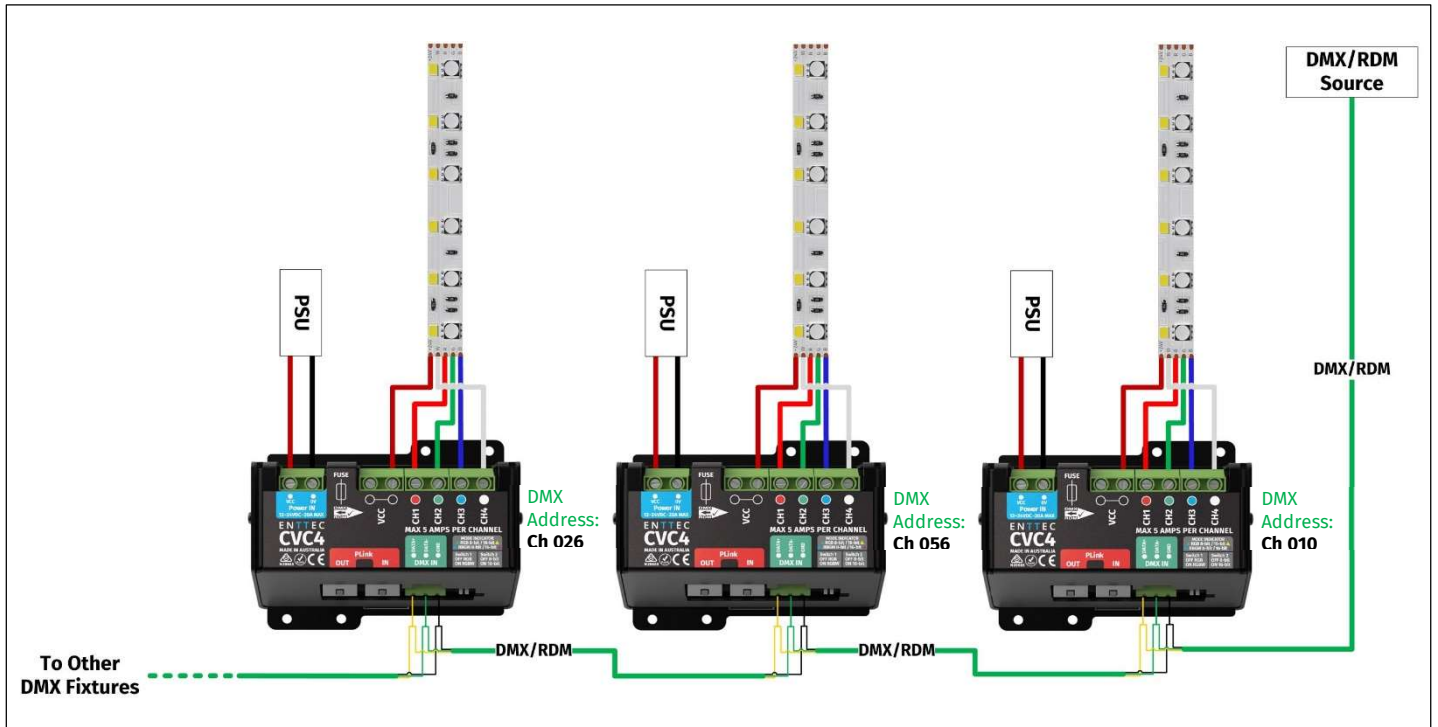

Updating firmware over RDM using ENTTEC RDM Controller

To update the CVC4's firmware with a new version from the ENTTEC website, use a DMX USB Pro / Pro MK2 and the basic version of ENTTEC RDM Controller Software. Firstly, connect your CVC4's to your DMX USB Pro and computer to carry out a **[Full Discovery]** to identify your CVC4's. Select the device you want to update from the left hand list and select 'ENTTEC Firmware update...' to upload the firmware file.

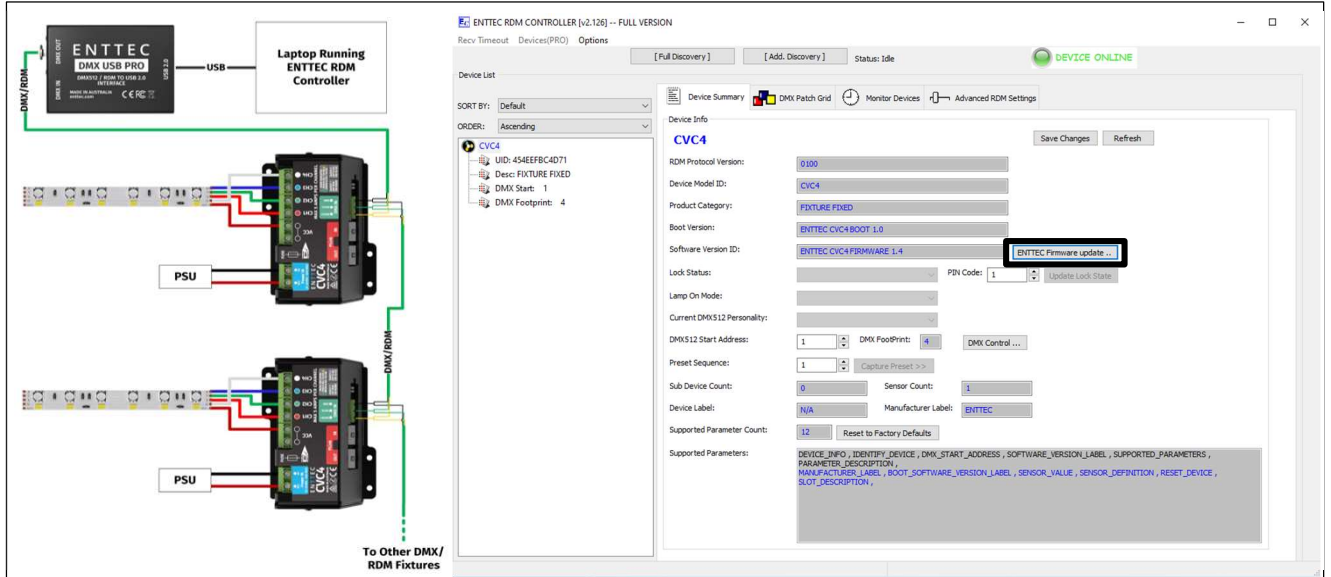

Combined System

Both the CVC4's auto-addressing PLink functionality and RDM addressing capabilities can be combined to create chains of CVC4's that will update their address starting from the RDM addressed CVC4 at the beginning of the chain.

This makes the CVC4 perfect for integration into custom set pieces comprising of multiple LED strips. Modifying the CVC4's DMX address at the beginning of each PLink chain through RDM will result in all following CVC4's auto incrementing their address to follow.

The following diagram depicts all CVC4s set to a 16-Bit RGBW operating mode (8ch Per CVC4):

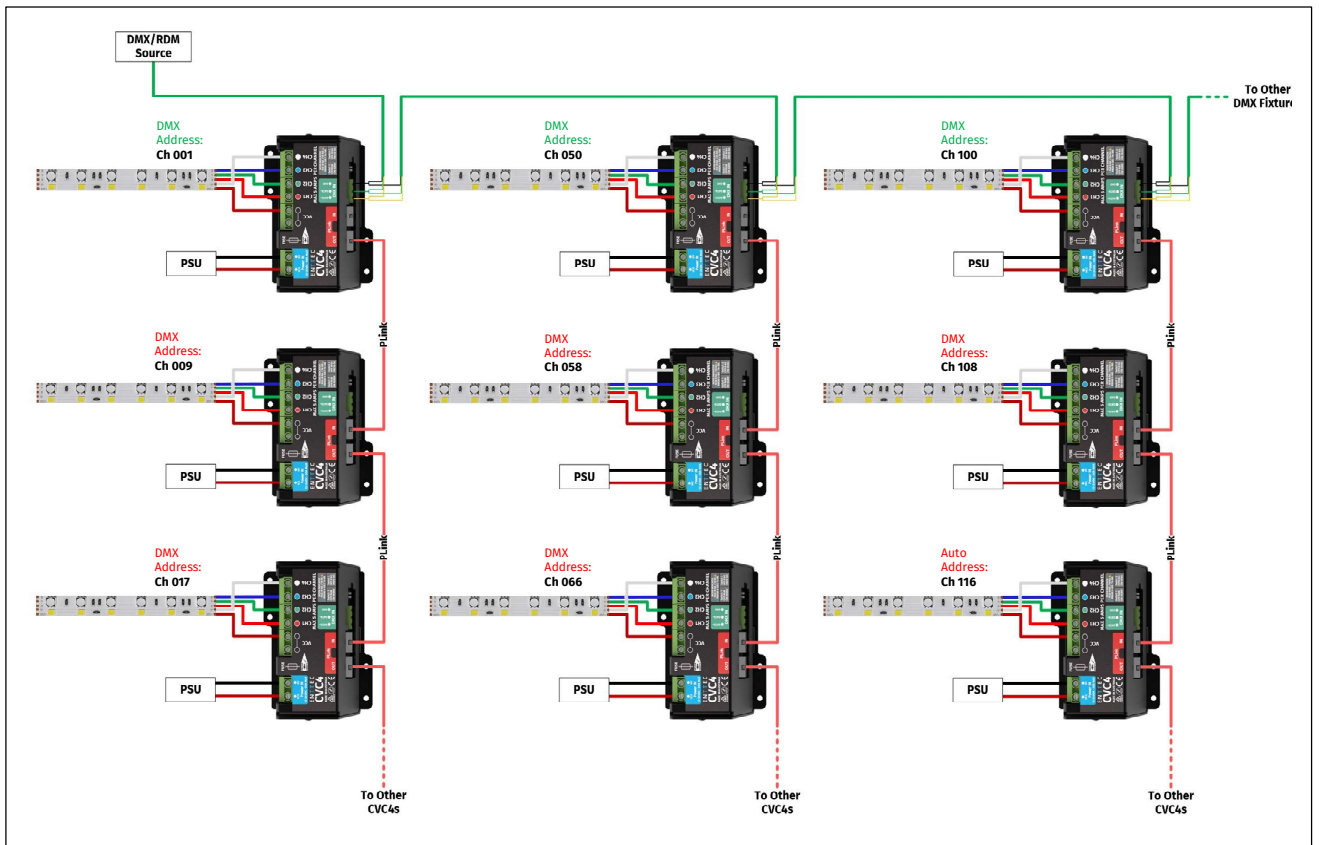

Surface mounting the CVC4

The CVC features 4 * M4 surface mounting holes for either screws or bolts.

Warnings

- If installing on a vertical surface or overhead, ensure your mounting solution is capable of holding a minimum of 10* the weight of the CVC4 and attached cabling.
- If installing this device to a surface ensure there are no cables, pipes or other services behind that could be damaged.
- To avoid damage to your CVC4's metalwork DO NOT use countersunk screws or bolts when surface mounting the CVC4.

Installation Guidance

- When using screws, hold the CVC4 up to the surface it is to be mounted to and use a pencil to mark the hole positions onto the surface. – Remove the CVC to protect it from swarf and dust before drilling a pilot hole to hold your device.
- To avoid scratching the CVC4's paintwork, ENTTEC recommends the use of a M4 washer between each bolt/screw and the surface of the CVC4.

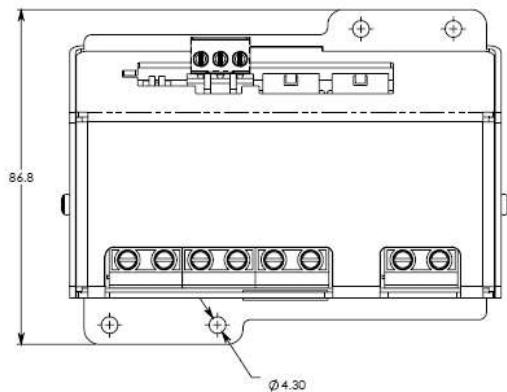

Wiring the CVC4

Warnings

- Multiple CVC4's can be powered from one PSU rated to handle the maximum current requirement of all connected LED strip. Ensure the cable between your power supply to each CVC4 is capable of handling the full power capability of your CVC4.
- Never plug PLink ports into Ethernet outlets or network infrastructure.
- All cables should be restrained with adequate slack to ensure the cables can't be pulled out.
- Make all the connections before you plug in the main power supply.

Installation Guidance

Locate the power supply as close as possible to the CVC4 to reduce the impact of voltage drop.

ENTTEC recommend the use of stranded copper cabling rated to handle the maximum current deliverable from your selected power supply.

ENTTEC recommends the use of cable ferrules for all stranded cables connected to the CVC4's screw terminal to ensure a reliable connection.

Maximum recommended data extensions between devices when using PLink are 300 meters over Cat6 cable.

Setting the CVC4's fixture operating mode

The CVC4's two DIP switches and mode LED allow users to quickly set the DMX operating mode. Each of the CVC4's 4 modes results in the mode LED lighting with a corresponding color.

Installers unfamiliar with DMX can set both DIP switches to allow the indicators to all show the same color, providing data is connected, the devices will either auto address if using Plinks or allow addresses to be set using RDM later.

Note: The CVC4 allows for operation mode to be set by DIP Switches only – Not via RDM

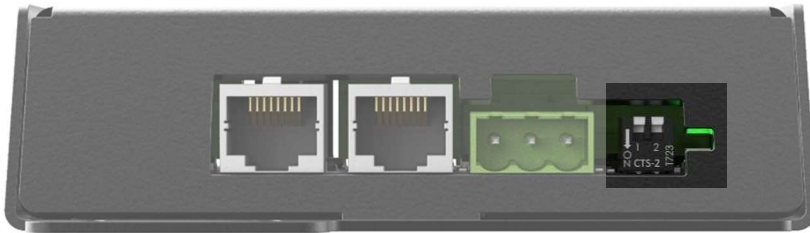

Fixture Operating Modes	DMX Channel Footprint	Indicator LED Colour	Fixture Footprint								
			1	2	3	4	5	6	7	8	
8-Bit RGB	3ch	Green	Red	Green	Blue						
8-Bit RGBW	4ch	Blue	Red	Green	Blue	White					
16-Bit RGB	6ch	Yellow	Red	Red Fine	Green	Green Fine	Blue	Blue Fine			
16-Bit RGBW	8ch	Magenta	Red	Red Fine	Green	Green Fine	Blue	Blue Fine	White	White Fine	

In addition to being useful for setup, the mode LED indicator acts as a quick troubleshooting tool for users to identify any incorrectly configured CVC's units in one glance.

If one CVC's fixture operating mode is changed, the following CVC4's in the chain will update their address to ensure no gaps or overlaps between each CVC's address.

When patching DMX addresses into your lighting console factor in the mode of each CVC4 if mixing Operating Modes within the same chain.

The following table shows a selection of CVC4's in different operating modes and the impact this has on the fixture patch:

Position in Plink Chain	Operating Mode	Resolution	Channel Footprint	DMX Footprint
1	RGB	8-Bit	3ch	001 -> 003
2	RGB	16-Bit	6ch	004 -> 009
3	RGBW	8-Bit	4ch	010 -> 013
4	RGBW	16-Bit	8ch	014 -> 021
5	RGB	8-Bit	3ch	022 -> 024

Replacing the user serviceable fuse

If the CVC4's outputs get short circuited or the total dimmable load is higher than 20A, the CVC4's internal fuse will blow.

Users may wish to replace this fuse for one of a lower rated value and shorter blow time if the total power draw of their system is lower than 20A. – ENTTEC cannot be held accountable for replacement fuses selected by end users or damage caused to the product when replacing the fuse.

To replace this fuse:

Ensure your system is powered down and power supplies have discharged.

Disconnect all cabling from your CVC4.



Ensure you are electrically grounded before opening this product to stop the device being damaged by Electro-Static Discharge (ESD). Do not touch this products PCB at any time.

Remove each of the cases side screws using a PH2 screwdriver and lift the top half of the case.

Remove the old fuse by holding the CVC4 in place with one hand and pinching and pulling up on the top plastic part of the fuse with the other.

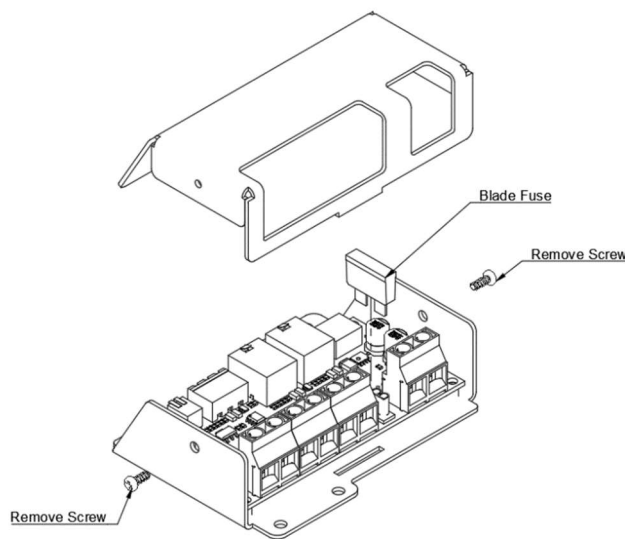
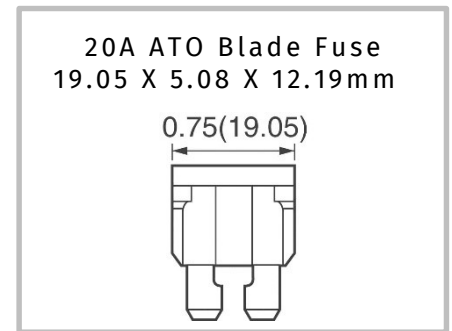

Insert the replacement fuse into the fuse holder ensuring a secure fit.

If ever unsure contact ENTTEC.



Click [here](#) for online illustration video.

Servicing, Inspection & Maintenance

-  ■ **The device has no user serviceable parts. If your installation has become damaged, parts should be replaced.**
-  ■ **Power down the device and ensure a method is in place to stop the system from becoming energized during servicing, inspection & maintenance.**

Key areas to examine during inspection:

- Ensure all connectors are mated securely and show no sign of damage or corrosion.
- Ensure all cabling has not obtained physical damage or been crushed.
- Check for dust or dirt build up on the device and schedule cleaning if necessary.
- Dirt or dust buildup can limit the ability for a device to dissipate heat and can lead to damage.



The replacement device should be installed in accordance with all steps within the installation guide.

To order replacement devices or accessories contact your reseller or message ENTTEC directly.

Cleaning

Dust and dirt build up can limit the ability for the device to dissipate heat resulting in damage. It's important that the device is cleaned in a schedule fit for the environment it is installed within to ensure maximum product longevity.

Cleaning schedules will vary greatly depending on the operating environment. Generally, the more extreme the environment, the shorter the interval between cleaning.

-  ■ **Before cleaning, power down your system and ensure a method is in place to stop the system from becoming energized until cleaning is complete.**
-  ■ **Do not use abrasive, corrosive, or solvent-based cleaning products on an device.**
-  ■ **Do not spray device or accessories. The device is an IP20 product.**

To clean an ENTTEC device, use low-pressure compressed air to remove dust, dirt and loose particles. If deemed necessary, wipe the device with a damp microfiber cloth.

A selection of environmental factors that may increase the need for frequent cleaning include:

- Use of stage fog, smoke or atmospheric devices.
- High airflow rates (i.e., in close proximity to air conditioning vents).
- High pollution levels or cigarette smoke.
- Airborne dust (from building work, the natural environment or pyrotechnic effects).

If any of these factors are present, inspect all elements of the system soon after installation to see whether cleaning is necessary, then check again at frequent intervals. This procedure will allow you to determine a reliable cleaning schedule for your installation.

Package Contents

- CVC4

Ordering Information

For further support and to browse ENTTEC's range of products visit the [ENTTEC website](#).

Item	Part No.
CVC4	73925

enttec.com

MELBOURNE AUS / LONDON UK / RALEIGH-DURHAM USA

Due to constant innovation, information within this document is subject to change.