

Approval body for construction products  
and types of construction

Bautechnisches Prüfamt

An institution established by the Federal and  
Laender Governments



## European Technical Assessment

ETA-18/0119  
of

English translation prepared by DIBt - Original version in German language

### General Part

Technical Assessment Body issuing the  
European Technical Assessment:

Deutsches Institut für Bautechnik

Trade name of the construction product

Hilti installation channel MQ-41/3,  
Hilti installation channel MQ-41/3 LL,  
Hilti installation channel MQ-41 D,  
Hilti installation channel MQ-21.5,  
Hilti installation channel MQ-41 and  
Hilti installation channel MQ-41-L

Product family  
to which the construction product belongs

Products related to installation systems supporting  
technical equipment for building services such as pipes,  
conduits, ducts and cables

Manufacturer

Hilti AG  
Feldkircherstraße 100  
9494 Schaan  
FÜRSTENTUM LIECHTENSTEIN

Manufacturing plant

L1000511

This European Technical Assessment  
contains

46 pages including 42 annexes which form an integral  
part of this assessment

This European Technical Assessment is  
issued in accordance with Regulation (EU)  
No 305/2011, on the basis of

EAD 280016-00-0602

**European Technical Assessment**

**ETA-18/0119**

English translation prepared by DIBt

Page 2 of 46 |

The European Technical Assessment is issued by the Technical Assessment Body in its official language. Translations of this European Technical Assessment in other languages shall fully correspond to the original issued document and shall be identified as such.

Communication of this European Technical Assessment, including transmission by electronic means, shall be in full. However, partial reproduction may only be made with the written consent of the issuing Technical Assessment Body. Any partial reproduction shall be identified as such.

This European Technical Assessment may be withdrawn by the issuing Technical Assessment Body, in particular pursuant to information by the Commission in accordance with Article 25(3) of Regulation (EU) No 305/2011.

## Specific Part

### 1 Technical description of the product

Objects of this European Technical Assessment are Hilti installation channels MQ-41/3, MQ-41/3 LL, MQ-41 D, MQ-21.5, MQ-41 and MQ-41-L. The Hilti installation channels MQ-41/3, MQ-41/3 LL, MQ-41, MQ-41-L and MQ 21.5 consist of thin-walled steel with parallel flanges and a connecting web. The flanges are turned at the end. The flanges of the channels MQ-41, MQ-41 D, MQ-41-L and MQ 21.5 are designed with an offset. The turned flange ends are designed with a toothed shape which makes it possible to force-fit the channels to specific channel system fixtures. Different recesses in the back of the channels in the form of oblong holes and round holes allow the use of fasteners and fixtures. The MQ-41 D installation channel consists of two profiles of similar type as MQ-41, which are connected in the area of the holes in the back of the channels in a shape-fitting and force-fitting way. The channels are delivered in lengths of 2 m, 3 m and 6 m for the channels MQ-41, MQ-41-L and MQ 21.5 and in lengths of 3 m or 6 m for the channels MQ-41/3, MQ-41/3 LL and MQ-41 D. The channels can be cut to length as required.

Annex A describes the dimensions and materials of the Hilti installation channels MQ-41/3, MQ-41/3 LL, MQ-41 D, MQ-21.5, MQ-41 and MQ-41-L. The requirements for performance assessment are given in Annex B.

### 2 Specification of the intended use in accordance with the applicable European Assessment Document (EAD)

The performance given in Section 3 can only be assumed if the Hilti installation channels MQ-41/3, MQ-41/3 LL, MQ-41 D, MQ-21.5, MQ-41 and MQ-41-L are used in compliance with the specifications and under boundary conditions set out in Annexes A to D. The test and assessment methods on which this European Technical Assessment is based lead to an assumption of a working life of the Hilti installation channels MQ-41/3, MQ-41/3 LL, MQ-41 D, MQ-21.5, MQ-41 and MQ-41-L of at least 50 years in final use under ambient temperatures in indoor areas. The indications given on the working life cannot be interpreted as a guarantee given by the producer, but are to be regarded only as a means for choosing the right products in relation to the expected economically reasonable working life of the works.

In accordance with the European Assessment Document EAD 280016-00-0602, the product is intended to be used in

- a) installations for the support of sprinkler kits;
- b) installations for the support of other building service elements such as pipes, conduits, ducts and cables.

### 3 Performance of the product and references to the methods used for its assessment

#### 3.1 Safety in case of fire (BWR 2)

Essential characteristic	Performance
Reaction to fire	A1

### 3.2 Safety and accessibility in use (BWR 4)

Essential characteristic	Performance
Dimensions and materials of Hilti installation channels MQ-41/3, MQ-41/3 LL, MQ-41 D, MQ-21.5, MQ-41 and MQ-41-L	see Annex A
Resistance of Hilti installation channels MQ-41/3, MQ-41/3 LL, MQ-41 D, MQ-21.5, MQ-41 and MQ-41-L at ambient temperature	see Annex C
Resistance and deformation of Hilti installation channels MQ-41/3, MQ-41/3 LL, MQ-41, MQ-41-L and MQ 21.5 at elevated temperatures	see Annex D

### 4 Assessment and verification of constancy of performance (AVCP) system applied, with reference to its legal base

In accordance with the European Assessment Document EAD 280016-00-0602, the following legal bases apply:

- In case of intended use a) specified in Section 2:  
Decision of the commission N° 1996/577/EC:  
System 1 applies for the assessment and verification of constancy of performance (AVCP).
- In case of intended use b) specified in Section 2:  
Decision of the commission N° 1999/472/EC:  
System 3 applies for the assessment and verification of constancy of performance (AVCP).

### 5 Technical details necessary for the implementation of the AVCP system, as provided for in the applicable EAD

The technical details necessary for the implementation of the system for the assessment and verification of constancy of performance are laid down in the control plan (confidential part of this European Technical Assessment) deposited at Deutsches Institut für Bautechnik.

Table A1: Dimensions and materials of installation channels MQ-41/3, MQ-41/3 LL and MQ-41 D

Illustration <sup>1)</sup>	Item number	Designation	Length [m]	Materials and coatings
	369596	MQ-41/3 3M	3	S250GD+Z275-M-A-C in accordance with EN 10346
	369597	MQ-41/3 6M	6	
	2048102	MQ-41/3 3M LL	3	S250GD+Z275-M-A-C in accordance with EN 10346
	2048103	MQ-41/3 6M LL	6	
	369603	MQ-41 D 3m	3	S250GD+Z275-M-A-C in accordance with EN 10346
	369604	MQ-41 D 6m	6	

<sup>1)</sup> Dimensions in mm

Hilti installation channel MQ-41/3, Hilti installation channel MQ-41/3 LL and  
Hilti installation channel MQ-41 D

Annex A1

Product description  
Dimensions and materials

Table A2: Dimensions and materials of installation channels MQ-21.5, MQ-41 and MQ-41-L

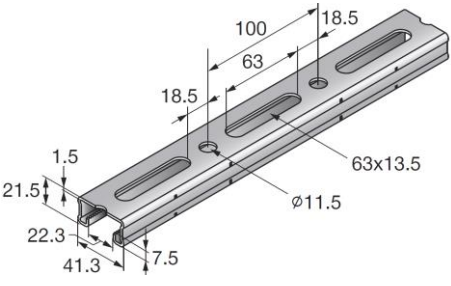
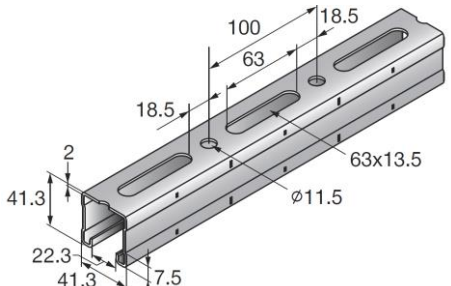
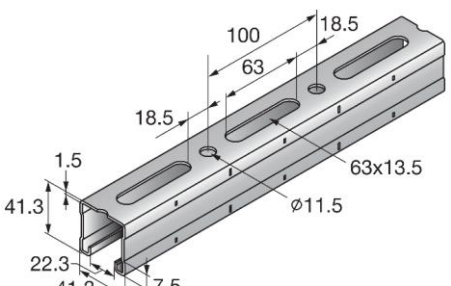
Illustration <sup>2)</sup>	Item number	Designation	Length [m]	Materials and coatings
	2184773	MQ-21.5 6m	6	S280GD+Z140-M-A-C in accordance with EN 10346
	2184772	MQ-21.5 3m	3	
	2184771	MQ-21.5 2m	2	
	369592	MQ-41 6m	6	S250GD+Z275-M-A-C in accordance with EN 10346
	369591	MQ-41 3m	3	
	304559	MQ-41 2m	2	
	2141964	MQ-41-L 6m	6	S250GD+Z140-M-A-C in accordance with EN 10346
	2141965	MQ-41-L 3m	3	
	2141966	MQ-41-L 2m	2	

<sup>2)</sup> Dimensions in mm

Hilti installation channel MQ-21.5, Hilti installation channel MQ-41 and  
Hilti installation channel MQ-41-L

Annex A2

Product description  
Dimensions and materials

- Hilti MQ-41/3, MQ-41/3 LL, MQ-41 D, MQ-21.5, MQ-41 and MQ-41-L installation channels are used to transfer building services component loads such as ducts and equipment for sprinklers, water, heating, cooling, ventilation, electrical and other systems. Hilti MQ-41/3, MQ-41/3 LL, MQ-41 D, MQ-21.5, MQ-41 and MQ-41-L installation channels are performing this loadbearing function under the conditions described in Section 2 of this European Technical Assessment.
- Hilti MQ-41/3, MQ-41/3 LL, MQ-21.5, MQ-41 and MQ-41-L installation channels are used in building services engineering installation systems at ambient and elevated temperatures. Hilti MQ-41 D installation channel in the scope of this European Technical Assessment is used only for applications at ambient temperatures.
- The resistance and deformation at ambient and elevated temperatures apply for static and centric actions.
- The resistance and deformation at elevated temperatures are referring to the boundary conditions of the standard temperature / time curve (STTC) in accordance with EN 1363-1.
- MQ-41/3, MQ-41/3 LL, MQ-21.5, MQ-41 and MQ-41-L channels used in headrail systems are installed with the channel profile open underneath. Tested fire-proof components are attached underneath using Hilti MQA-M10-B, MQA-M12-B or MQA-M16-B pipe ring saddles. The channels are mounted on the base material for use at elevated temperatures using MQZ-L11 or MQZ-L13 drilled plates in conjunction with suitable fasteners. MQ-41/3 and MQ-41/3 LL channels can be mounted on the base material for use at ambient temperatures with suitable fasteners through the longhole without using MQZ-L11 or MQZ-L13 drilled plates. MQ-21.5, MQ-41 and MQ-41-L channels can be mounted on the base material for use at ambient and elevated temperatures with suitable fasteners through the roundhole without using MQZ-L11 or MQZ-L13 drilled plates. See informative Annex E1 through Annex E4.
- In the case of suspended channel systems, the channel profiles are opened upwards or downwards. On the underside or on the top of suspended channel systems, tested fireproof components must be force-fitted and secured using Hilti MQZ-L11 or MQZ-L13 drilled plates, nuts and threaded rods. Hilti MQA-M10-B, MQA-M12-B or MQA-M16-B pipe ring saddles can also be used as an alternative. Implementing the nodes between the channel and the threaded rod used for the suspension must take place using force-fitted Hilti MQZ-L11 or MQZ-L13 bored plates and nuts as well as threaded rods. See informative Annex E5 and Annex E6.
- The installation channels are cut to length centrally between the longholes or the roundholes at the marking. The cut channel lies within a range of 2 mm from both sides of the marking.
- Threaded rods and other fixtures are only to be guided through the closed roundholes or longholes in the back of the channel.
- The anchoring used with the base material must be suitable and have a fireproof certificate.
- The channels must be installed by appropriately qualified personnel and under the supervision of the site manager.
- The manufacturer's general installation instructions of the manufacturer in informative Annex E7 through Annex E10 apply.

Hilti installation channel MQ-41/3, Hilti installation channel MQ-41/3 LL, Hilti installation channel MQ-41 D, Hilti installation channel MQ-21.5, Hilti installation channel MQ-41 and Hilti installation channel MQ-41-L	Annex B1
Requirements for performance assessment	

- The pull-through resistance from the holes in the back of the channels at ambient and elevated temperatures results in connection with the fasteners as per Table B2.

Table B2: Fasteners for channel fixation through back holes

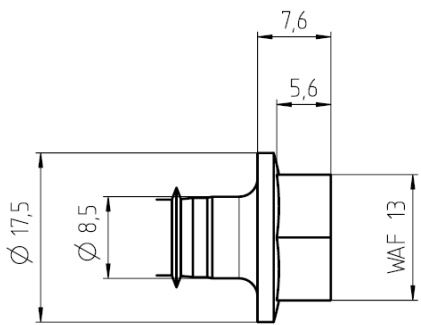
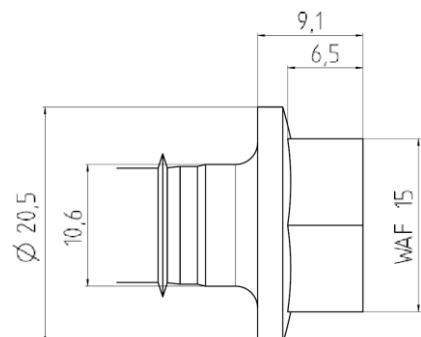
No.	Material and geometry of fastener	Illustration [Dimensions in mm]	Installation channel
1	Steel galvanized, $f_{uk} \geq 810 \text{ N/mm}^2$ Hexagon head, WAF 13 mm		MQ-21.5 (round hole) MQ-41 (round hole) MQ-41-L (round hole)
2	Steel galvanized, $f_{uk} \geq 805 \text{ N/mm}^2$ Hexagon head, WAF 15 mm		MQ-41/3 MQ-41/3 LL
3	Bolt: M12, strength class 4.8 in accordance with DIN 976-1 Washer: EN ISO 7089 – 13 – 200 HV Hexagon nut: M12, strength class 8 in accordance with ISO 4032	–	MQ-41/3 MQ-41/3 LL
4	Bolt: M10, strength class 4.8 in accordance with DIN 976-1 Washer: EN ISO 7089 – 10.5 – 200 HV Hexagon nut: M10, strength class 8 in accordance with ISO 4032	–	MQ-21.5 (round hole) MQ-41 (round hole) MQ-41-L (round hole)

Hilti installation channel MQ-41/3, Hilti installation channel MQ-41/3 LL,  
Hilti installation channel MQ-21.5, Hilti installation channel MQ-41 and  
Hilti installation channel MQ-41-L

Annex B2

Requirements for performance assessment



Table B3: Section properties of installation channels

Description	Symbol	MQ-41/3	MQ-41/3 LL	MQ-41 D	MQ-21.5	MQ-41	MQ-41-L	Unit
Classification cross section in accordance with EN 1993-1-1	-	3	3	3	3	3	3	-
Cross section areas	A	375.88	379.93	545.97	142.71	263.62	199.57	mm <sup>2</sup>
	A <sub>tot</sub>	375.88	379.93	545.97	142.71	263.62	199.57	mm <sup>2</sup>
Shear areas	A <sub>y</sub>	48.69	54.43	66.37	23.47	27.23	20.24	mm <sup>2</sup>
	A <sub>z</sub>	195.47	194.59	197.58	41.86	131.51	98.37	mm <sup>2</sup>
Centroid position	y <sub>C,0</sub>	19.15	19.15	0.00	0.00	19.65	0.00	mm
	z <sub>C,0</sub>	20.57	20.76	0.00	-9.12	20.52	-19.91	mm
Moments of inertia	I <sub>y</sub>	76963.50	78224.80	323585.00	9168.75	57501.00	44773.00	mm <sup>4</sup>
	I <sub>z</sub>	107949.00	108011.00	154070.00	37416.40	76416.00	58981.50	mm <sup>4</sup>
Inclination of principal axes	α	90.00	90.00	0.00	90.00	90.00	90.00	°
Polar moments of inertia	I <sub>p</sub>	184913.00	186236.00	477656.00	46585.10	133917.00	103754.00	mm <sup>4</sup>
	I <sub>p,M</sub>	778900.00	780561.00	477656.00	115093.00	601859.00	469974.00	mm <sup>4</sup>
Radii of gyration	i <sub>y</sub>	14.31	14.35	24.35	8.02	14.77	14.98	mm
	i <sub>z</sub>	16.95	16.86	16.80	16.19	17.03	17.19	mm
Polar radii of gyration	i <sub>p</sub>	22.18	22.14	29.58	18.07	22.54	22.80	mm
	i <sub>p,M</sub>	45.52	45.33	29.58	28.40	47.78	48.53	mm
Warping radius of gyration	i <sub>ω,M</sub>	7.02	7.02	17.32	6.85	7.19	7.44	mm
Torsional constant	J	848.88	856.29	575.03	76.58	269.75	112.13	mm <sup>4</sup>
Secondary torsional constant	J <sub>s</sub>	105319.00	105394.00	91246.30	25157.50	74075.40	565590.00	mm <sup>4</sup>
Location of the shear center	y <sub>M,0</sub>	19.15	19.15	0.00	0.00	19.65	0.00	mm
	z <sub>M,0</sub>	60.32	60.31	0.00	12.77	62.63	22.92	mm
	y <sub>M</sub>	0.00	0.00	0.00	0.00	0.00	0.00	mm
	z <sub>M</sub>	39.75	39.55	0.00	21.90	42.11	42.84	mm
Warping constants	I <sub>ω,C</sub>	2.09277E+08	2.07678E+08	1.43225E+08	23255400.00	1.66135E+08	1.34296E+08	mm <sup>6</sup>
	I <sub>ω,M</sub>	38387600	38417600.00	1.43225E+08	5395050.00	31116700.00	26017600	mm <sup>6</sup>
	r <sub>ω,M</sub>	0.00	0.00	0.00	0.00	0.00	0.00	-
Section moduli	S <sub>y,max</sub>	4002.48	4108.45	7834.29	928.54	2906.72	2248.07	mm <sup>3</sup>
	S <sub>y,min</sub>	-3487.10	-3514.15	-7833.74	-788.66	-2672.22	-2093.62	mm <sup>3</sup>
	S <sub>z,max</sub>	5227.58	5230.56	7460.71	1811.93	3700.53	2856.29	mm <sup>3</sup>
	S <sub>z,min</sub>	-5277.58	-5230.56	-7460.71	-1811.93	-3700.54	-2856.25	mm <sup>3</sup>
Torsional section modulus	S <sub>t</sub>	282.96	285.43	287.51	51.06	134.88	75.76	mm <sup>3</sup>
Max. plastic bending moment	M <sub>pl,y,k</sub>	NPA <sup>3)</sup>	NPA	NPA	NPA	NPA	NPA	kNm
	M <sub>pl,z,k</sub>	NPA	NPA	NPA	NPA	NPA	NPA	kNm
Max. plastic section moduli	Z <sub>y</sub>	NPA	NPA	NPA	NPA	NPA	NPA	mm <sup>3</sup>
	Z <sub>z</sub>	NPA	NPA	NPA	NPA	NPA	NPA	mm <sup>3</sup>
Plastic shear areas	A <sub>pl,y</sub>	NPA	NPA	NPA	NPA	NPA	NPA	mm <sup>2</sup>
	A <sub>pl,z</sub>	NPA	NPA	NPA	NPA	NPA	NPA	mm <sup>2</sup>
Area bisecting axis position	f <sub>y,0</sub>	NPA	NPA	NPA	NPA	NPA	NPA	mm
	f <sub>z,0</sub>	NPA	NPA	NPA	NPA	NPA	NPA	mm
Plastic shear forces	V <sub>pl,y,k</sub>	NPA	NPA	NPA	NPA	NPA	NPA	kN
	V <sub>pl,z,k</sub>	NPA	NPA	NPA	NPA	NPA	NPA	kN
Plastic axial force	N <sub>pl,k</sub>	NPA	NPA	NPA	NPA	NPA	NPA	kN
Buckling curves	BC <sub>y</sub>	c	c	c	c	c	c	-
	BC <sub>z</sub>	c	c	c	c	c	c	-

<sup>3)</sup> NPA: No performance assessed

Hilti installation channel MQ-41/3, Hilti installation channel MQ-41/3 LL,  
Hilti installation channel MQ-41 D, Hilti installation channel MQ-21.5,  
Hilti installation channel MQ-41 and Hilti installation channel MQ-41-L

Annex B3

Requirements for performance assessment

Table C1: Characteristic pull-through resistance from the holes in the back of the channels at ambient temperatures

Installation channel	Characteristic pull-through resistance <sup>4)</sup>	Partial safety coefficient <sup>5)</sup>
	$F_{Rk}$ [kN]	$\gamma_M$
MQ-41/3	13.01	2.32
MQ-41/3 LL		
MQ-41 D	NPA <sup>6)</sup>	–
MQ-21.5	11.95	2.85
MQ-41	17.54	4.17
MQ-41-L	8.59	2.05

<sup>4)</sup> For MQ-41/3 and MQ-41/3 LL, the performance applies regardless of the position of the fastener in the longholes in the back of the channels;  
For MQ-21.5, MQ-41 und MQ-41-L, the performance applies with the position of the fastener in the roundholes in the back of the channels.

<sup>5)</sup> provided that no other national regulations apply

<sup>6)</sup> NPA: No performance assessed

Hilti installation channel MQ-41/3, Hilti installation channel MQ-41/3 LL,  
Hilti installation channel MQ-41 D, Hilti installation channel MQ-21.5,  
Hilti installation channel MQ-41 and Hilti installation channel MQ-41-L

Annex C

Resistance at ambient temperature

Table D1: Pull-through resistance  $F_{Rk,t}$  from the roundholes in the back of the channels at elevated temperatures after 30, 60 and 90 minutes

Installation channel	Pull-through resistance		
	$F_{Rk,t}$ [kN]		
	t = 30 minutes	t = 60 minutes	t = 90 minutes
MQ-41	1.92	1.01	0.71
MQ-41-L	1.29	NPA <sup>7)</sup>	NPA
MQ-21.5	1.75	NPA	NPA

<sup>7)</sup> NPA: No performance assessed

Hilti installation channel MQ-41, Hilti installation channel MQ-41-L  
and Hilti installation channel MQ-21.5

Annex D1

Resistance at elevated temperatures

Table D2: Channel material stress at different temperatures and 2% elongation

Temperature [°C]	Stress <sup>8)</sup> [N/mm <sup>2</sup> ]			
	MQ-41/3 or MQ-41/3 LL	MQ-41	MQ-41-L	MQ-21.5
800	26.51	25.06	20.83	28.53
842 <sup>9)</sup>	19.00	16.77	14.11	21.80
850	17.57	15.19	12.83	20.52
900	12.82	11.21	10.69	17.24
945 <sup>10)</sup>	12.05	10.49	9.19	12.91
950	11.96	10.41	9.02	12.43
1000	10.58	8.82	7.02	10.52
1006 <sup>11)</sup>	10.50	8.72	6.98	10.48
1049 <sup>12)</sup>	9.91	7.97	6.73	10.18
1050	9.90	7.96	6.73	10.17

<sup>8)</sup> determined based on unsteady thermal creep tests

<sup>9)</sup> furnace temperature according to standard temperature / time curve after 30 minutes

<sup>10)</sup> furnace temperature according to standard temperature / time curve after 60 minutes

<sup>11)</sup> furnace temperature according to standard temperature / time curve after 90 minutes

<sup>12)</sup> furnace temperature according to standard temperature / time curve after 120 minutes

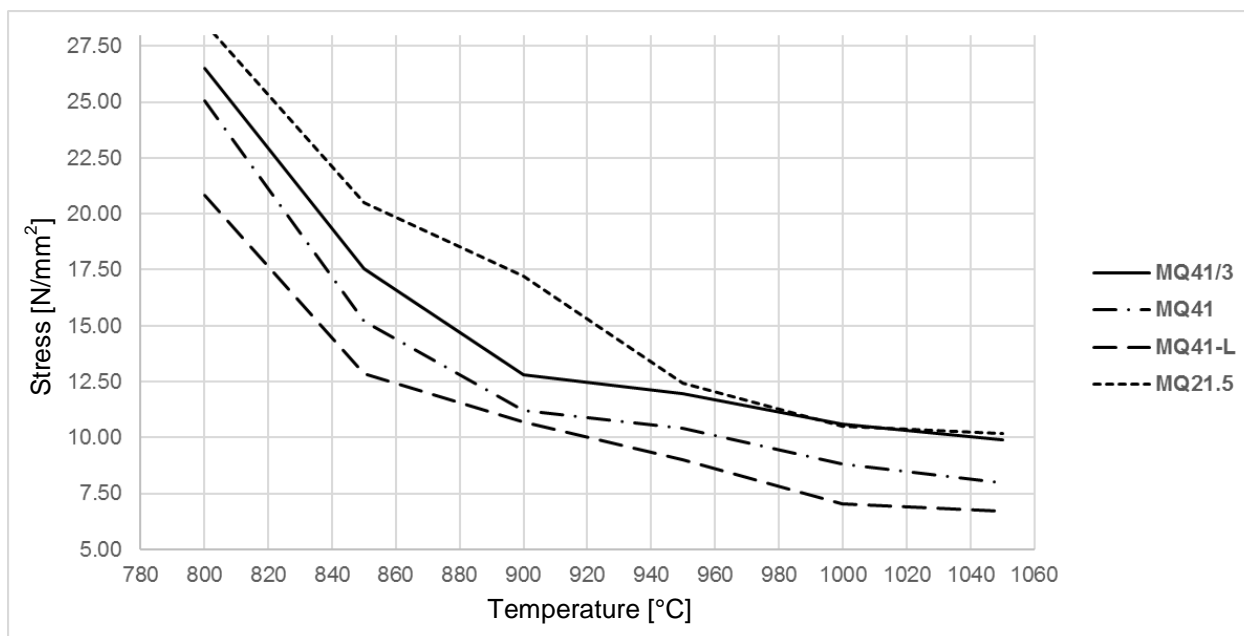

Figure D2: Channel material stress at 2% strain

Hilti installation channel MQ-41/3, Hilti installation channel MQ-41/3 LL,  
Hilti installation channel MQ-21.5, Hilti installation channel MQ-41 and  
Hilti installation channel MQ-41-L

Annex D2

Stress-strain behaviour at elevated temperatures

Table D3: Calculation-based deformation at elevated temperatures for installation channels MQ-41/3 and MQ-41/3 LL

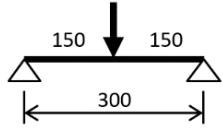
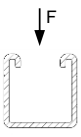
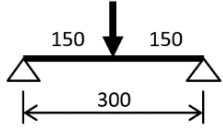
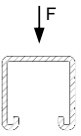
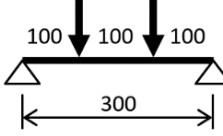
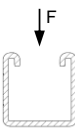
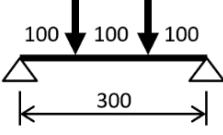
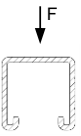
System [Dimensions in mm]	Load direction	$\sigma_B$	$V^{13)}$	$F^{14)}$	$\bar{\delta}_{t_{max,B}}$	$t_{max,B}$	$\bar{\delta}_{30}$	$\bar{\delta}_{60}$	$\bar{\delta}_{90}$	$\bar{\delta}_{120}$
		[N/mm <sup>2</sup> ]	-	[N]	[mm]	[min]	[mm]	[mm]	[mm]	[mm]
		5	0.50	228.38	35.53	120.00	1.38	13.86	21.48	35.53
		10	0.50	461.05	38.74	120.00	2.26	15.52	24.24	38.74
		15	0.50	693.72	44.14	120.00	3.45	18.00	28.31	44.14
		20	0.50	926.38	59.74	120.00	4.98	23.86	38.03	59.74
		25	0.50	1159.05	72.32	107.09	7.14	32.54	55.25	152.22
		30	0.50	1391.72	60.10	73.76	10.48	45.71	152.09	152.22
		5	0.50	228.38	35.47	120.00	1.37	13.83	21.43	35.47
		10	0.50	461.05	37.88	120.00	2.02	15.09	23.50	37.88
		15	0.50	693.72	42.03	120.00	3.00	17.03	26.64	42.03
		20	0.50	926.38	51.00	120.00	4.18	20.82	32.85	51.00
		25	0.50	1159.05	37.29	80.01	5.79	26.79	70.44	102.25
		5	0.67	171.29	35.90	120.00	1.43	14.06	21.85	35.90
		10	0.67	345.79	40.56	120.00	2.73	16.34	25.63	40.56
		15	0.67	520.29	52.67	120.00	4.32	21.31	33.87	52.67
		20	0.67	694.79	75.00	120.00	6.69	31.03	49.89	75.00
		25	0.67	869.29	84.98	107.92	10.66	43.74	68.22	152.22
		5	0.67	171.29	35.75	120.00	1.42	13.99	21.70	35.75
		10	0.67	345.79	39.43	120.00	2.48	15.84	24.74	39.43
		15	0.67	520.29	46.04	120.00	3.75	18.89	29.65	46.04
		20	0.67	694.79	61.98	120.00	5.49	25.54	40.35	61.98
		25	0.67	869.29	64.98	100.42	7.99	34.69	54.92	-
		30	0.67	1043.79	53.97	68.34	12.00	46.05	-	-

<sup>13)</sup> Momentum degree of fullness without contribution from channel dead weight

<sup>14)</sup> Size of the designated system's single load

Symbols:

- $\sigma_B$  Channel bending stress
- $V$  Momentum degree of fullness
- $F$  Load
- $\bar{\delta}_{t_{max,B}}$  Deformation of the channel at the point in time of stability failure or of the plastic hinging
- $t_{max,B}$  Time in which loss of rigidity or plastic hinging of the channel occurs under bending stress
- $\bar{\delta}_{30}$  Displacement after exposure time of 30 minutes to elevated temperatures
- $\bar{\delta}_{60}$  Displacement after exposure time of 60 minutes to elevated temperatures
- $\bar{\delta}_{90}$  Displacement after exposure time of 90 minutes to elevated temperatures
- $\bar{\delta}_{120}$  Displacement after exposure time of 120 minutes to elevated temperatures

Thermal analyses as well as calculations are referring to the boundary conditions of STTC.

Hilti installation channel MQ-41/3 and Hilti installation channel MQ-41/3 LL

Annex D3

Deformation at elevated temperatures

Table D4: Calculation-based deformation at elevated temperatures for installation channels MQ-41/3 and MQ-41/3 LL

System [Dimensions in mm]	Load direction	$\sigma_B$	$V^{13)}$	$F^{14)}$	$\delta_{t_{max},B}$	$t_{max,B}$	$\delta_{30}$	$\delta_{60}$	$\delta_{90}$	$\delta_{120}$
		[N/mm <sup>2</sup> ]	-	[N]	[mm]	[min]	[mm]	[mm]	[mm]	[mm]
		5	0.5	132.46	36.39	120.00	1.59	14.33	22.24	36.39
		10	0.5	272.06	44.98	120.00	3.95	18.71	29.54	44.98
		15	0.5	411.66	62.13	120.00	7.10	26.15	41.96	62.13
		20	0.5	551.26	104.64	120.00	11.31	42.64	69.55	104.64
		25	0.5	690.86	117.01	98.34	17.56	66.29	105.99	199.40
		30	0.5	830.46	106.27	68.76	28.04	94.16	248.76	253.70
		5	0.5	132.46	36.06	120.00	1.54	14.16	21.93	36.06
		10	0.5	272.06	41.96	120.00	3.18	17.24	27.02	41.96
		15	0.5	411.66	51.24	120.00	5.52	21.66	34.21	51.24
		20	0.5	551.26	72.77	120.00	8.29	31.01	49.06	72.77
		25	0.5	690.86	102.25	120.00	12.06	44.70	70.44	102.25
		30	0.5	830.46	86.77	81.26	17.55	61.69	-	-
		5	0.80	165.58	38.33	120.00	1.94	15.38	24.11	38.33
		10	0.80	340.08	54.75	120.00	6.39	23.04	36.94	54.75
		15	0.80	514.58	105.04	84.17	11.77	47.40	148.06	184.14
		20	0.80	689.08	93.67	49.18	21.26	194.92	235.68	253.70
		25	0.80	863.58	35.68	27.93	163.26	225.24	253.48	253.70
		30	0.80	1038.08	27.05	23.35	187.95	243.73	253.48	253.70
		5	0.80	165.58	36.97	120.00	1.72	14.65	22.78	36.97
		10	0.80	340.08	47.37	120.00	4.71	19.92	31.41	47.37
		15	0.80	514.58	64.51	120.00	8.21	28.07	44.34	64.51
		20	0.80	689.08	90.89	113.75	12.98	45.55	68.48	-
		25	0.80	863.58	74.29	69.17	20.08	64.16	-	-
		30	0.80	1038.08	64.08	42.09	31.28	-	-	-
		5	0.67	55.19	37.41	120.00	1.78	14.88	23.23	37.41
		10	0.67	113.36	50.00	120.00	5.32	21.09	33.48	50.00
		15	0.67	171.53	78.05	120.00	9.55	34.01	53.83	78.05
		20	0.67	229.69	113.97	120.00	15.78	56.14	83.44	113.97
		25	0.67	287.86	140.77	120.00	25.97	77.66	108.87	140.77
		30	0.67	346.03	162.19	117.50	42.50	96.39	129.74	207.98
		5	0.67	55.19	36.61	120.00	1.65	14.45	22.45	36.61
		10	0.67	113.36	45.17	120.00	4.11	18.85	29.65	45.17
		15	0.67	171.53	59.59	120.00	7.16	25.58	40.49	59.59
		20	0.67	229.69	89.54	120.00	11.11	39.97	62.32	89.54
		25	0.67	287.86	83.60	85.00	16.79	58.32	-	-
		30	0.67	346.03	75.29	56.26	25.67	-	-	-

<sup>13)</sup> Momentum degree of fullness without contribution from channel dead weight

<sup>14)</sup> Size of the designated system's single load

List of symbols see Annex D3

Hilti installation channel MQ-41/3 and Hilti installation channel MQ-41/3 LL

Annex D4

Deformation at elevated temperatures

Table D5: Calculation-based deformation at elevated temperatures for installation channels MQ-41/3 and MQ-41/3 LL

System [Dimensions in mm]	Load direction	$\sigma_B$	$V^{13)}$	$F^{14)}$	$\bar{\delta}_{t_{max},B}$	$t_{max,B}$	$\bar{\delta}_{30}$	$\bar{\delta}_{60}$	$\bar{\delta}_{90}$	$\bar{\delta}_{120}$
		[N/mm <sup>2</sup> ]	-	[N]	[mm]	[min]	[mm]	[mm]	[mm]	[mm]
		5	0.5	89.72	37.80	120.00	1.95	15.09	23.49	37.80
		10	0.5	189.44	54.69	120.00	6.59	23.71	37.82	54.69
		15	0.5	289.15	88.10	120.00	12.77	38.85	62.36	88.10
		20	0.5	388.87	152.11	120.00	21.01	68.99	107.88	152.11
		25	0.5	488.58	199.40	120.00	33.45	105.09	155.72	199.40
		30	0.5	588.29	183.72	85.00	53.13	141.14	248.76	355.17
		5	0.5	89.72	36.93	120.00	1.81	14.63	22.66	36.93
		10	0.5	189.44	47.65	120.00	4.80	20.26	31.93	47.65
		15	0.5	289.15	64.63	120.00	9.03	28.38	45.13	64.63
		20	0.5	388.87	101.06	120.00	14.08	45.02	70.98	101.06
		25	0.5	488.58	126.68	105.42	20.88	68.18	104.23	-
		30	0.5	588.29	113.11	71.26	30.90	94.77	-	-
		5	0.86	157.01	41.88	120.00	2.66	17.27	27.42	41.88
		10	0.86	331.51	107.73	120.00	11.89	33.30	56.92	107.73
		15	0.86	506.01	184.14	120.00	23.34	104.82	148.06	184.14
		20	0.86	680.51	51.98	29.18	127.10	194.92	235.68	270.33
		25	0.86	855.01	36.27	24.18	163.26	225.24	259.10	295.75
		30	0.86	1029.51	33.65	22.10	187.95	243.73	280.16	311.98
		5	0.86	157.01	38.58	120.00	2.15	15.51	24.19	38.58
		10	0.86	331.51	58.11	120.00	7.54	25.49	40.47	58.11
		15	0.86	506.01	87.14	120.00	14.35	40.19	63.12	87.14
		20	0.86	680.51	96.76	86.25	23.43	67.99	-	-
		25	0.86	855.01	82.43	46.26	36.63	-	-	-
		30	0.86	1029.51	75.31	34.60	54.77	-	-	-
		5	0.67	26.17	39.84	120.00	2.32	16.20	25.46	39.84
		10	0.67	55.25	64.06	120.00	9.24	28.26	45.22	64.06
		15	0.67	84.34	107.50	120.00	17.42	51.92	79.27	107.50
		20	0.67	113.42	152.23	120.00	29.17	85.21	118.31	152.23
		25	0.67	142.50	183.14	120.00	46.78	112.45	147.95	183.14
		30	0.67	171.59	207.98	120.00	69.55	134.11	171.86	207.98
		5	0.67	26.17	37.87	120.00	1.99	15.14	23.53	37.87
		10	0.67	55.25	53.20	120.00	6.39	23.07	36.52	53.20
		15	0.67	84.34	77.89	120.00	11.90	34.90	55.32	77.89
		20	0.67	113.42	121.08	120.00	18.96	58.94	89.09	121.08
		25	0.67	142.50	107.19	75.01	29.18	86.80	-	-
		30	0.67	171.59	95.91	44.59	44.40	-	-	-

<sup>13)</sup> Momentum degree of fullness without contribution from channel dead weight

<sup>14)</sup> Size of the designated system's single load

List of symbols see Annex D3

Hilti installation channel MQ-41/3 and Hilti installation channel MQ-41/3 LL

Annex D5

Deformation at elevated temperatures

Table D6: Calculation-based deformation at elevated temperatures for installation channels MQ-41/3 and MQ-41/3 LL

System [Dimensions in mm]	Load direction	$\sigma_B$	$V^{13)}$	$F^{14)}$	$\delta_{t_{max};B}$	$t_{max,B}$	$\delta_{30}$	$\delta_{60}$	$\delta_{90}$	$\delta_{120}$
		[N/mm <sup>2</sup> ]	-	[N]	[mm]	[min]	[mm]	[mm]	[mm]	[mm]
		5	0.5	64.71	39.79	120.00	2.45	16.18	25.27	39.79
		10	0.5	142.26	67.91	120.00	10.22	30.54	49.10	67.91
		15	0.5	219.82	118.55	120.00	20.45	55.34	87.37	118.55
		20	0.5	297.38	202.14	120.00	33.90	99.74	149.83	202.14
		25	0.5	374.93	256.64	120.00	53.47	146.62	207.67	256.64
		30	0.5	452.49	292.63	119.17	82.09	191.04	248.76	359.01
		5	0.5	64.71	38.05	120.00	2.16	15.25	23.61	38.05
		10	0.5	142.26	54.62	120.00	6.81	23.98	37.96	54.62
		15	0.5	219.82	81.28	120.00	13.36	36.82	58.71	81.28
		20	0.5	297.38	132.14	120.00	21.28	61.67	96.20	132.14
		25	0.5	374.93	153.03	95.84	31.96	95.35	140.86	-
		30	0.5	452.49	142.98	65.01	47.38	131.00	-	-
		5	0.89	145.60	46.41	120.00	3.55	19.65	31.63	46.41
		10	0.89	320.10	149.86	120.00	19.22	48.31	110.45	149.86
		15	0.89	494.60	211.68	120.00	40.54	136.35	176.46	211.68
		20	0.89	669.10	61.78	27.10	127.10	194.92	235.68	270.33
		25	0.89	843.60	85.46	22.93	163.26	225.24	259.10	295.75
		30	0.89	1018.10	36.98	20.85	187.95	243.73	280.16	311.98
		5	0.89	145.60	40.02	120.00	2.55	16.27	25.41	40.02
		10	0.89	320.10	69.45	120.00	10.47	31.58	50.23	69.45
		15	0.89	494.60	107.88	120.00	21.20	52.17	81.08	107.88
		20	0.89	669.10	105.36	74.17	34.71	87.33	-	-
		25	0.89	843.60	90.19	40.01	53.46	-	-	-
		30	0.89	1018.10	81.33	30.85	75.45	-	-	-
		5	0.67	14.56	43.33	120.00	3.11	18.12	28.66	43.33
		10	0.67	32.01	82.40	120.00	14.59	37.91	60.70	82.40
		15	0.67	49.46	138.22	120.00	27.91	73.38	107.23	138.22
		20	0.67	66.91	189.41	120.00	46.31	115.49	153.39	189.41
		25	0.67	84.36	224.43	120.00	71.01	146.93	186.41	224.43
		30	0.67	101.81	251.27	120.00	97.80	171.55	212.61	251.27
		5	0.67	14.56	39.48	120.00	2.43	16.00	24.92	39.48
		10	0.67	32.01	63.24	120.00	9.14	28.36	45.10	63.24
		15	0.67	49.46	99.34	120.00	17.84	46.34	73.19	99.34
		20	0.67	66.91	154.86	118.33	28.82	80.55	117.81	-
		25	0.67	84.36	134.87	70.01	44.29	116.77	-	-
		30	0.67	101.81	122.14	42.09	66.19	-	-	-

<sup>13)</sup> Momentum degree of fullness without contribution from channel dead weight

<sup>14)</sup> Size of the designated system's single load

List of symbols see Annex D3











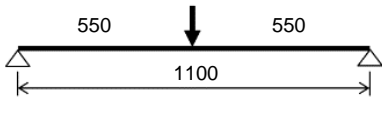

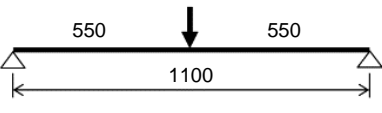
Hilti installation channel MQ-41/3 and Hilti installation channel MQ-41/3 LL

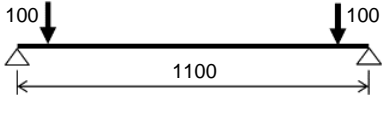
Annex D6

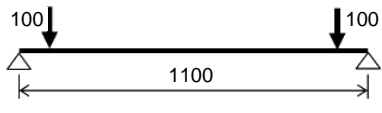
Deformation at elevated temperatures

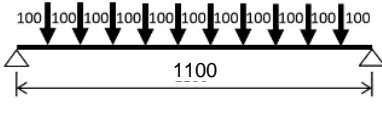

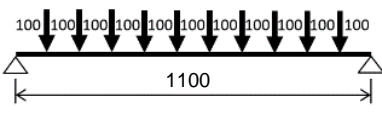
Table D7: Calculation-based deformation at elevated temperatures for installation channels MQ-41/3 and MQ-41/3 LL

System [Dimensions in mm]	Load direction	$\sigma_B$	$V^{13)}$	$F^{14)}$	$\delta_{t_{max},B}$	$t_{max,B}$	$\delta_{30}$	$\delta_{60}$	$\delta_{90}$	$\delta_{120}$
		[N/mm <sup>2</sup> ]	-	[N]	[mm]	[min]	[mm]	[mm]	[mm]	[mm]
		5	0.5	47.75	42.50	120.00	3.11	17.65	27.69	42.50
		10	0.5	111.21	84.54	120.00	14.91	39.28	63.33	84.54
		15	0.5	174.66	152.99	120.00	30.10	75.44	116.60	152.99
		20	0.5	238.12	253.18	120.00	49.85	133.85	194.08	253.18
		25	0.5	301.57	316.03	120.00	77.29	190.76	261.37	316.03
		30	0.5	365.03	359.01	120.00	114.60	243.07	309.53	359.01
		5	0.5	47.75	39.43	120.00	2.60	16.00	24.75	39.43
		10	0.5	111.21	62.88	120.00	9.18	28.41	45.17	62.88
		15	0.5	174.66	100.75	120.00	18.49	46.87	74.69	100.75
		20	0.5	238.12	164.99	120.00	29.80	80.61	123.97	164.99
		25	0.5	301.57	173.86	84.59	45.13	125.07	-	-
		30	0.5	365.03	166.08	55.43	66.60	-	-	-
		5	0.91	131.32	51.73	120.00	4.58	22.39	36.55	51.73
		10	0.91	305.82	172.29	120.00	28.45	75.38	136.81	172.29
		15	0.91	480.32	238.74	120.00	69.86	159.36	202.29	238.74
		20	0.91	654.82	270.33	120.00	127.10	194.92	235.68	270.33
		25	0.91	829.32	295.75	120.00	163.26	225.24	259.10	295.75
		30	0.91	1003.82	311.98	120.00	187.95	243.73	280.16	311.98
		5	0.91	131.32	41.80	120.00	3.08	17.22	26.90	41.80
		10	0.91	305.82	82.66	120.00	13.81	38.72	61.53	82.66
		15	0.91	480.32	133.06	120.00	29.49	67.01	102.73	133.06
		20	0.91	654.82	120.45	66.67	48.43	108.91	-	-
		25	0.91	829.32	105.72	36.68	73.31	-	-	-
		30	0.91	1003.82	96.53	29.60	-	-	-	-
		5	0.67	8.75	48.11	120.00	4.21	20.75	33.09	48.11
		10	0.67	20.39	104.47	120.00	21.42	50.06	79.62	104.47
		15	0.67	32.02	169.62	120.00	40.92	97.01	136.36	169.62
		20	0.67	43.65	225.92	120.00	66.46	145.97	188.02	225.92
		25	0.67	55.29	265.07	120.00	97.11	181.01	224.76	265.07
		30	0.67	66.92	294.94	120.00	126.94	208.33	253.36	294.94
		5	0.67	8.75	41.46	120.00	2.98	17.07	26.64	41.46
		10	0.67	20.39	75.04	120.00	12.35	34.66	55.26	75.04
		15	0.67	32.02	123.62	120.00	24.83	59.74	93.74	123.62
		20	0.67	43.65	170.13	105.00	40.54	103.90	147.69	-
		25	0.67	55.29	154.72	62.09	62.06	149.82	-	-
		30	0.67	66.92	141.72	38.76	90.20	-	-	-

<sup>13)</sup> Momentum degree of fullness without contribution from channel dead weight

<sup>14)</sup> Size of the designated system's single load











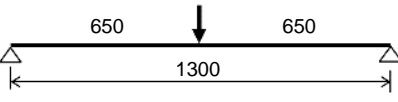

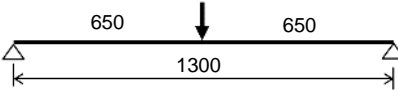
List of symbols see Annex D3

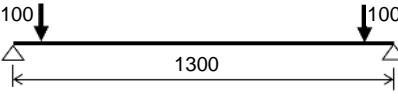
Hilti installation channel MQ-41/3 and Hilti installation channel MQ-41/3 LL

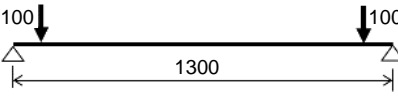
Annex D7

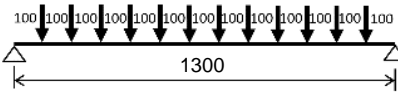
Deformation at elevated temperatures

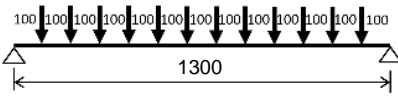
Table D8: Calculation-based deformation at elevated temperatures for installation channels MQ-41/3 and MQ-41/3 LL

System [Dimensions in mm]	Load direction	$\sigma_B$	$V^{13)}$	$F^{14)}$	$\bar{\delta}_{t_{max},B}$	$t_{max,B}$	$\bar{\delta}_{30}$	$\bar{\delta}_{60}$	$\bar{\delta}_{90}$	$\bar{\delta}_{120}$
		[N/mm <sup>2</sup> ]	-	[N]	[mm]	[min]	[mm]	[mm]	[mm]	[mm]
		5	0.5	35.14	46.07	120.00	3.95	19.58	30.91	46.07
		10	0.5	88.83	104.75	120.00	20.73	50.08	80.71	104.75
		15	0.5	142.52	190.06	120.00	41.80	98.83	149.08	190.06
		20	0.5	196.21	303.18	120.00	68.74	170.20	238.68	303.18
		25	0.5	249.91	375.68	120.00	104.42	235.35	314.72	375.68
		30	0.5	303.60	425.50	120.00	149.25	294.87	370.85	425.50
		5	0.5	35.14	41.13	120.00	3.14	16.93	26.18	41.13
		10	0.5	88.83	72.85	120.00	11.94	33.78	53.87	72.85
		15	0.5	142.52	123.63	120.00	24.52	58.78	93.54	123.63
		20	0.5	196.21	201.19	120.00	39.94	102.56	155.13	201.19
		25	0.5	249.91	182.28	71.26	60.79	158.01	-	-
		30	0.5	303.60	155.87	40.01	89.37	-	-	-
		5	0.92	114.19	57.49	120.00	5.70	25.32	41.84	57.49
		10	0.92	288.69	195.07	120.00	39.80	103.44	158.37	195.07
		15	0.92	463.19	264.07	120.00	96.84	177.89	225.18	264.07
		20	0.92	637.69	309.47	120.00	149.84	223.77	270.02	309.47
		25	0.92	812.19	334.61	120.00	186.59	254.48	298.33	334.61
		30	0.92	986.69	349.63	120.00	213.06	274.66	315.34	349.63
		5	0.92	114.19	43.73	120.00	3.69	18.26	28.51	43.73
		10	0.92	288.69	97.08	120.00	17.48	46.60	73.98	97.08
		15	0.92	463.19	152.03	112.50	38.90	83.71	126.18	-
		20	0.92	637.69	113.56	45.01	64.10	-	-	-
		25	0.92	812.19	95.46	30.01	95.34	-	-	-
		30	0.92	986.69	92.10	26.26	-	-	-	-
		5	0.67	5.44	54.46	120.00	5.70	24.28	38.98	54.46
		10	0.67	13.75	129.56	120.00	29.82	64.68	101.48	129.56
		15	0.67	22.06	201.47	120.00	56.33	121.83	166.04	201.47
		20	0.67	30.37	261.82	120.00	88.88	176.19	222.06	261.82
		25	0.67	38.68	304.81	120.00	124.15	214.59	262.42	304.81
		30	0.67	46.99	337.85	120.00	156.62	244.37	293.72	337.85
		5	0.67	5.44	43.91	120.00	3.64	18.39	28.76	43.91
		10	0.67	13.75	89.18	120.00	16.08	42.21	67.35	89.18
		15	0.67	22.06	150.92	120.00	33.01	75.28	117.01	150.92
		20	0.67	30.37	174.17	85.42	54.33	129.32	-	-
		25	0.67	38.68	145.31	42.09	82.78	-	-	-
		30	0.67	46.99	126.36	30.85	116.76	-	-	-

<sup>13)</sup> Momentum degree of fullness without contribution from channel dead weight

<sup>14)</sup> Size of the designated system's single load

List of symbols see Annex D3

Hilti installation channel MQ-41/3 and Hilti installation channel MQ-41/3 LL

Annex D8

Deformation at elevated temperatures

Table D9: Calculation-based deformation at elevated temperatures for installation channel MQ-41

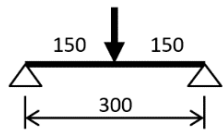
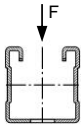
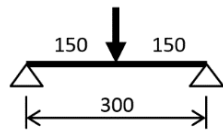
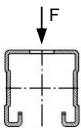
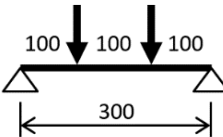
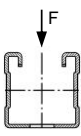
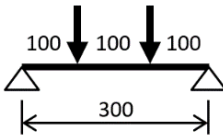
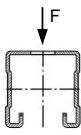
System [Dimensions in mm]	Load direction	$\sigma_B$	$V^{13)}$	$F^{14)}$	$\delta_{t_{max},B}$	$t_{max,B}$	$\delta_{30}$	$\delta_{60}$	$\delta_{90}$	$\delta_{120}$
		[N/mm <sup>2</sup> ]	-	[N]	[mm]	[min]	[mm]	[mm]	[mm]	[mm]
		5	0.5	175.10	5.70	120.00	5.70	5.70	5.70	5.70
		10	0.5	353.25	7.23	120.00	6.76	6.76	6.76	7.23
		15	0.5	531.40	17.95	93.33	8.09	9.99	16.44	58.20
		20	0.5	709.55	18.34	43.33	10.27	68.30	135.70	152.22
		25	0.5	887.70	19.05	31.67	14.27	151.91	152.09	152.22
		30	0.5	1065.84	18.91	28.34	143.70	151.91	-	-
		5	0.5	175.10	5.76	120.00	5.76	5.76	5.76	5.76
		10	0.5	353.25	8.26	120.00	6.91	6.91	7.28	8.26
		15	0.5	531.40	17.06	96.67	8.53	11.33	16.31	50.72
		20	0.5	709.55	17.49	40.00	11.36	52.81	152.09	152.22
		25	0.5	887.70	13.87	28.34	33.66	151.91	152.09	-
		30	0.5	1065.84	10.66	23.34	151.60	-	-	-
		5	0.67	131.33	5.94	120.00	5.94	5.94	5.94	5.94
		10	0.67	264.94	10.70	120.00	7.39	7.39	9.47	10.70
		15	0.67	398.55	24.36	120.00	9.45	14.49	20.63	24.36
		20	0.67	532.16	40.28	120.00	13.21	25.13	34.16	40.28
		25	0.67	665.77	42.94	78.33	20.20	36.53	-	-
		30	0.67	799.38	44.37	46.67	31.03	-	-	-
		5	0.67	131.33	6.03	120.00	6.03	6.03	6.03	6.03
		10	0.67	264.94	12.15	120.00	7.61	7.67	10.65	12.15
		15	0.67	398.55	39.57	120.00	10.06	17.35	26.67	39.57
		20	0.67	532.16	43.99	61.67	14.86	41.59	80.71	92.13
		25	0.67	665.77	35.10	31.67	26.62	81.08	-	-
		30	0.67	799.38	20.58	25.00	69.53	-	-	-

<sup>13)</sup> Momentum degree of fullness without contribution from channel dead weight

<sup>14)</sup> Size of the designated system's single load

List of symbols see Annex D3

Hilti installation channel MQ-41

Annex D9

Deformation at elevated temperatures

Table D10: Calculation-based deformation at elevated temperatures for installation channel MQ-41

System [Dimensions in mm]	Load direction	$\sigma_B$	$V^{13)}$	$F^{14)}$	$\delta_{t_{max},B}$	$t_{max,B}$	$\delta_{30}$	$\delta_{60}$	$\delta_{90}$	$\delta_{120}$
		[N/mm <sup>2</sup> ]	-	[N]	[mm]	[min]	[mm]	[mm]	[mm]	[mm]
		5	0.5	101.81	6.76	120.00	6.76	6.76	6.76	6.76
		10	0.5	208.70	20.45	120.00	9.67	13.50	18.21	20.45
		15	0.5	315.59	58.21	120.00	13.47	29.05	45.20	58.21
		20	0.5	422.48	85.13	88.33	20.06	68.34	135.71	213.28
		25	0.5	529.37	87.33	48.33	34.72	189.22	253.48	253.70
		30	0.5	636.26	35.07	26.67	143.66	253.18	-	-
		5	0.5	101.81	6.77	120.00	6.77	6.77	6.77	6.77
		10	0.5	208.70	20.72	120.00	9.72	13.79	18.52	20.72
		15	0.5	315.59	50.72	120.00	13.65	28.36	41.00	50.72
		20	0.5	422.48	53.95	61.67	20.52	52.81	198.93	253.70
		25	0.5	529.37	49.00	33.33	33.66	210.15	253.48	-
		30	0.5	636.26	48.33	28.34	157.90	-	-	-
		5	0.80	127.27	7.77	120.00	7.71	7.71	7.71	7.77
		10	0.80	260.88	31.70	120.00	12.15	20.71	27.92	31.70
		15	0.80	394.49	56.48	95.00	18.98	41.40	54.92	-
		20	0.80	528.10	58.44	45.00	32.96	-	-	-
		25	0.80	661.71	54.82	30.00	54.82	-	-	-
		30	0.80	795.32	19.57	21.67	-	-	-	-
		5	0.80	127.27	8.30	120.00	7.80	7.80	7.95	8.30
		10	0.80	260.88	34.66	120.00	12.39	22.27	30.63	34.66
		15	0.80	394.49	65.54	120.00	19.75	43.95	57.58	65.54
		20	0.80	528.10	92.13	120.00	33.23	64.35	80.71	92.13
		25	0.80	661.71	81.90	61.67	52.41	81.08	-	-
		30	0.80	795.32	78.01	33.33	69.53	-	-	-
		5	0.67	42.42	7.34	120.00	7.34	7.34	7.34	7.34
		10	0.67	86.96	28.41	120.00	11.14	18.21	25.05	28.41
		15	0.67	131.50	60.06	120.00	16.66	36.76	50.94	60.06
		20	0.67	176.03	93.99	120.00	26.88	58.98	78.24	93.99
		25	0.67	220.57	111.05	98.33	44.33	80.45	105.14	160.98
		30	0.67	265.11	109.68	70.00	66.66	100.60	199.35	222.25
		5	0.67	42.42	7.40	120.00	7.40	7.40	7.40	7.40
		10	0.67	86.96	29.50	120.00	11.32	19.00	26.11	29.50
		15	0.67	131.50	67.29	120.00	17.16	39.13	54.88	67.29
		20	0.67	176.03	89.02	83.33	28.17	65.55	126.64	178.15
		25	0.67	220.57	85.94	43.33	48.45	132.52	194.49	249.61
		30	0.67	265.11	71.34	28.34	111.71	190.73	253.48	253.70

<sup>13)</sup> Momentum degree of fullness without contribution from channel dead weight

<sup>14)</sup> Size of the designated system's single load

List of symbols see Annex D3

Hilti installation channel MQ-41

Annex D10

Deformation at elevated temperatures

Table D11: Calculation-based deformation at elevated temperatures for installation channel MQ-41

System [Dimensions in mm]	Load direction	$\sigma_B$	$V^{13)}$	$F^{14)}$	$\delta_{tmax,B}$	$t_{max,B}$	$\delta_{30}$	$\delta_{60}$	$\delta_{90}$	$\delta_{120}$
		[N/mm <sup>2</sup> ]	-	[N]	[mm]	[min]	[mm]	[mm]	[mm]	[mm]
		5	0.5	69.25	8.35	120.00	8.35	8.35	8.35	8.35
		10	0.5	145.59	39.98	120.00	13.98	26.43	35.63	39.98
		15	0.5	221.94	102.55	120.00	21.48	53.98	80.75	102.55
		20	0.5	298.29	143.40	100.00	34.35	100.13	135.71	213.28
		25	0.5	374.64	132.95	53.33	61.57	189.22	292.59	355.17
		30	0.5	450.99	59.71	26.67	143.66	266.68	-	-
		5	0.5	69.25	8.38	120.00	8.38	8.38	8.38	8.38
		10	0.5	145.59	39.91	120.00	14.08	26.68	35.74	39.91
		15	0.5	221.94	96.36	120.00	21.69	53.02	74.88	96.36
		20	0.5	298.29	107.39	68.33	34.76	93.85	198.93	271.50
		25	0.5	374.64	94.81	35.00	59.43	210.15	315.51	-
		30	0.5	450.99	61.79	26.67	157.90	-	-	-
		5	0.86	121.18	15.41	120.00	10.30	13.05	14.75	15.41
		10	0.86	254.79	56.07	120.00	18.97	38.11	49.90	56.07
		15	0.86	388.40	69.64	66.67	32.51	66.21	-	-
		20	0.86	522.01	66.51	31.67	59.19	-	-	-
		25	0.86	655.62	23.60	21.67	-	-	-	-
		30	0.86	789.23	21.22	20.01	-	-	-	-
		5	0.86	121.18	16.28	120.00	10.39	13.75	15.65	16.28
		10	0.86	254.79	61.46	120.00	19.43	41.75	55.21	61.46
		15	0.86	388.40	94.11	120.00	33.40	69.74	85.75	94.11
		20	0.86	522.01	119.52	120.00	54.63	92.87	109.92	119.52
		25	0.86	655.62	114.89	68.33	77.02	109.79	-	-
		30	0.86	789.23	107.29	36.67	94.12	-	-	-
		5	0.67	20.20	12.36	120.00	9.50	10.50	11.84	12.36
		10	0.67	42.47	52.23	120.00	16.83	34.48	46.43	52.23
		15	0.67	64.73	92.70	120.00	27.35	62.43	81.48	92.70
		20	0.67	87.00	129.88	120.00	45.25	90.02	113.53	129.88
		25	0.67	109.27	160.98	120.00	70.01	113.99	140.47	160.98
		30	0.67	131.54	164.21	88.33	94.58	135.57	199.35	222.25
		5	0.67	20.20	12.61	120.00	9.55	10.75	12.10	12.61
		10	0.67	42.47	54.14	120.00	17.08	35.89	48.32	54.14
		15	0.67	64.73	100.02	120.00	28.10	66.50	87.00	100.02
		20	0.67	87.00	144.27	111.67	47.52	97.63	126.64	178.15
		25	0.67	109.27	141.23	68.33	75.76	132.52	194.49	249.61
		30	0.67	131.54	133.11	35.00	111.71	190.73	257.28	286.01

<sup>13)</sup> Momentum degree of fullness without contribution from channel dead weight

<sup>14)</sup> Size of the designated system's single load

List of symbols see Annex D3

Hilti installation channel MQ-41

Annex D11

Deformation at elevated temperatures

Table D12: Calculation-based deformation at elevated temperatures for installation channel MQ-41

System [Dimensions in mm]	Load direction	$\sigma_B$	$V^{(13)}$	$F^{(14)}$	$\delta_{t_{max},B}$	$t_{max,B}$	$\delta_{30}$	$\delta_{60}$	$\delta_{90}$	$\delta_{120}$
		[N/mm <sup>2</sup> ]	-	[N]	[mm]	[min]	[mm]	[mm]	[mm]	[mm]
		5	0.5	50.25	13.20	120.00	10.55	11.42	12.58	13.20
		10	0.5	109.63	64.29	120.00	19.83	43.24	57.56	64.29
		15	0.5	169.01	149.37	120.00	32.05	82.42	120.06	149.37
		20	0.5	228.40	213.28	120.00	52.32	143.39	187.38	213.28
		25	0.5	287.78	226.29	86.67	93.04	189.22	292.59	362.32
		30	0.5	347.16	193.92	43.33	143.66	266.68	-	-
		5	0.5	50.25	13.38	120.00	10.57	11.57	12.77	13.38
		10	0.5	109.63	63.70	120.00	19.89	43.33	57.32	63.70
		15	0.5	169.01	128.95	120.00	32.21	80.63	108.46	128.95
		20	0.5	228.40	162.26	76.67	52.56	126.72	198.93	271.50
		25	0.5	287.78	144.45	38.33	86.37	210.15	315.51	-
		30	0.5	347.16	88.93	26.67	157.90	-	-	-
		5	0.89	113.06	24.94	120.00	13.63	20.83	23.72	24.94
		10	0.89	246.67	76.78	120.00	27.38	56.87	70.06	76.78
		15	0.89	380.28	83.00	50.00	51.06	-	-	-
		20	0.89	513.89	71.39	28.34	-	-	-	-
		25	0.89	647.50	21.73	20.01	-	-	-	-
		30	0.89	781.12	16.95	18.34	-	-	-	-
		5	0.89	113.06	26.09	120.00	13.75	22.27	25.11	26.09
		10	0.89	246.67	89.31	120.00	28.57	63.78	81.25	89.31
		15	0.89	380.28	125.73	120.00	49.75	95.51	115.27	125.73
		20	0.89	513.89	151.51	120.00	77.23	121.28	140.78	151.51
		25	0.89	647.50	151.86	76.67	101.28	140.26	-	-
		30	0.89	781.12	142.60	41.67	120.16	-	-	-
		5	0.67	11.31	21.06	120.00	12.49	17.80	20.17	21.06
		10	0.67	24.67	79.51	120.00	24.48	54.43	71.34	79.51
		15	0.67	38.03	124.55	120.00	41.12	89.01	111.86	124.55
		20	0.67	51.39	163.69	120.00	66.37	120.43	146.80	163.69
		25	0.67	64.75	195.28	120.00	95.48	145.85	175.02	195.28
		30	0.67	78.11	222.25	120.00	121.12	168.00	199.35	222.25
		5	0.67	11.31	20.97	120.00	12.46	17.87	20.13	20.97
		10	0.67	24.67	82.30	120.00	24.72	56.54	74.16	82.30
		15	0.67	38.03	131.58	120.00	42.10	94.61	118.46	131.58
		20	0.67	51.39	178.15	120.00	69.37	129.47	157.98	178.15
		25	0.67	64.75	215.60	113.33	102.08	159.04	194.49	249.61
		30	0.67	78.11	211.13	75.00	131.96	190.73	257.28	286.01

<sup>13)</sup> Momentum degree of fullness without contribution from channel dead weight

<sup>14)</sup> Size of the designated system's single load

List of symbols see Annex D3

Hilti installation channel MQ-41

Annex D12

Deformation at elevated temperatures

Table D13: Calculation-based deformation at elevated temperatures for installation channel MQ-41

System [Dimensions in mm]	Load direction	$\sigma_B$	$V^{(13)}$	$F^{(14)}$	$\delta_{t_{max};B}$	$t_{max,B}$	$\delta_{30}$	$\delta_{60}$	$\delta_{90}$	$\delta_{120}$
		[N/mm <sup>2</sup> ]	-	[N]	[mm]	[min]	[mm]	[mm]	[mm]	[mm]
		5	0.5	37.42	20.43	120.00	13.44	17.70	19.51	20.43
		10	0.5	86.01	92.85	120.00	27.23	63.57	83.49	92.85
		15	0.5	134.59	200.96	120.00	45.10	114.41	163.86	200.96
		20	0.5	183.18	252.09	120.00	73.70	179.55	225.45	252.09
		25	0.5	231.77	294.87	91.67	130.32	243.51	292.59	362.32
		30	0.5	280.35	282.79	70.00	187.10	266.68	-	-
		5	0.5	37.42	20.31	120.00	13.39	17.61	19.41	20.31
		10	0.5	86.01	90.85	120.00	27.14	63.19	82.33	90.85
		15	0.5	134.59	157.21	120.00	44.95	109.47	140.60	157.21
		20	0.5	183.18	237.27	111.67	72.74	156.69	198.93	271.50
		25	0.5	231.77	234.67	70.00	111.64	210.15	315.51	-
		30	0.5	280.35	214.16	36.67	157.90	-	-	-
		5	0.91	102.91	36.43	120.00	17.59	30.10	34.42	36.43
		10	0.91	236.52	95.42	118.33	37.53	74.62	88.36	-
		15	0.91	370.13	97.08	43.33	69.20	-	-	-
		20	0.91	503.75	35.47	21.67	-	-	-	-
		25	0.91	637.36	32.65	20.01	-	-	-	-
		30	0.91	770.97	26.07	18.34	-	-	-	-
		5	0.91	102.91	37.29	120.00	17.81	32.10	35.90	37.29
		10	0.91	236.52	117.85	120.00	39.61	87.20	108.03	117.85
		15	0.91	370.13	159.74	120.00	67.98	122.83	147.09	159.74
		20	0.91	503.75	187.52	120.00	100.87	150.83	174.29	187.52
		25	0.91	637.36	191.04	83.33	126.77	172.16	-	-
		30	0.91	770.97	178.42	45.00	147.35	-	-	-
		5	0.67	6.86	32.65	120.00	16.43	27.43	31.25	32.65
		10	0.67	15.77	108.67	120.00	34.17	76.91	98.24	108.67
		15	0.67	24.68	157.86	120.00	57.62	116.27	143.11	157.86
		20	0.67	33.58	198.14	120.00	89.31	150.66	180.11	198.14
		25	0.67	42.49	231.53	120.00	121.17	178.48	210.58	231.53
		30	0.67	51.40	259.54	120.00	148.67	201.72	236.11	259.54
		5	0.67	6.86	31.80	120.00	16.21	27.05	30.54	31.80
		10	0.67	15.77	112.84	120.00	34.31	80.08	102.48	112.84
		15	0.67	24.68	166.29	120.00	58.90	123.92	151.68	166.29
		20	0.67	33.58	211.30	120.00	93.49	162.53	193.07	211.30
		25	0.67	42.49	249.61	120.00	129.49	193.67	227.32	249.61
		30	0.67	51.40	286.01	120.00	160.36	220.19	257.28	286.01

<sup>13)</sup> Momentum degree of fullness without contribution from channel dead weight

<sup>14)</sup> Size of the designated system's single load

List of symbols see Annex D3

Hilti installation channel MQ-41

Annex D13

Deformation at elevated temperatures



Table D14: Calculation-based deformation at elevated temperatures for installation channel MQ-41

System [Dimensions in mm]	Load direction	$\sigma_B$	$V^{13)}$	$F^{14)}$	$\delta_{t_{max};B}$	$t_{max,B}$	$\delta_{30}$	$\delta_{60}$	$\delta_{90}$	$\delta_{120}$
		[N/mm <sup>2</sup> ]	-	[N]	[mm]	[min]	[mm]	[mm]	[mm]	[mm]
		5	0.5	27.92	29.74	120.00	17.08	25.78	28.44	29.74
		10	0.5	69.03	124.98	120.00	36.24	87.10	112.80	124.98
		15	0.5	110.14	249.93	120.00	60.63	148.49	207.15	249.93
		20	0.5	151.25	295.69	120.00	98.02	217.63	264.92	295.69
		25	0.5	192.36	362.32	120.00	169.86	282.46	332.49	362.32
		30	0.5	233.47	344.97	88.33	223.15	315.90	-	-
		5	0.5	27.92	29.47	120.00	17.00	25.58	28.19	29.47
		10	0.5	69.03	122.42	120.00	36.15	86.68	111.39	122.42
		15	0.5	110.14	197.51	120.00	60.52	142.21	178.79	197.51
		20	0.5	151.25	271.50	120.00	96.70	195.73	240.34	271.50
		25	0.5	192.36	315.51	90.00	142.52	244.57	315.51	-
		30	0.5	233.47	300.95	53.33	189.40	-	-	-
		5	0.92	90.73	48.92	120.00	22.10	40.60	46.13	48.92
		10	0.92	224.34	111.70	113.33	49.76	91.37	105.57	-
		15	0.92	357.96	108.38	40.00	85.94	-	-	-
		20	0.92	491.57	27.10	20.01	-	-	-	-
		25	0.92	625.18	21.59	18.34	-	-	-	-
		30	0.92	758.79	20.81	16.67	-	-	-	-
		5	0.92	90.73	49.41	120.00	22.46	42.78	47.57	49.41
		10	0.92	224.34	147.09	120.00	52.23	111.42	135.43	147.09
		15	0.92	357.96	194.90	120.00	87.51	151.80	180.04	194.90
		20	0.92	491.57	225.98	120.00	125.19	181.72	210.20	225.98
		25	0.92	625.18	231.95	88.33	153.60	205.37	-	-
		30	0.92	758.79	213.08	46.67	175.76	-	-	-
		5	0.67	4.32	47.43	120.00	21.42	39.57	45.32	47.43
		10	0.67	10.68	138.64	120.00	45.85	100.90	126.06	138.64
		15	0.67	17.05	192.39	120.00	76.26	144.08	175.18	192.39
		20	0.67	23.41	233.69	120.00	113.26	180.67	213.76	233.69
		25	0.67	29.77	268.80	120.00	147.08	210.94	246.33	268.80
		30	0.67	36.13	298.60	120.00	176.42	236.24	273.93	298.60
		5	0.67	4.32	45.46	120.00	20.89	38.55	43.64	45.46
		10	0.67	10.68	145.14	120.00	45.91	105.80	132.55	145.14
		15	0.67	17.05	204.30	120.00	78.27	154.55	187.03	204.30
		20	0.67	23.41	250.89	120.00	119.47	196.79	231.06	250.89
		25	0.67	29.77	290.74	120.00	158.37	231.38	268.24	290.74
		30	0.67	36.13	324.72	120.00	191.82	260.32	299.60	324.72

<sup>13)</sup> Momentum degree of fullness without contribution from channel dead weight

<sup>14)</sup> Size of the designated system's single load

List of symbols see Annex D3

Hilti installation channel MQ-41

Annex D14

Deformation at elevated temperatures

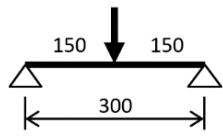
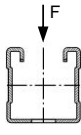
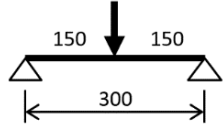
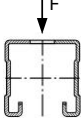
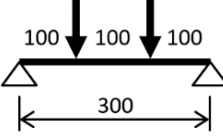
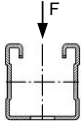
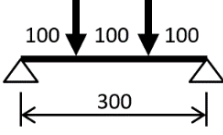
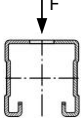

Table D15: Calculation-based deformation at elevated temperatures for installation channel MQ-41-L

System [Dimensions in mm]	Load direction	$\sigma_B$	$V^{13)}$	$F^{14)}$	$\delta_{t_{max},B}$	$t_{max,B}$	$\delta_{30}$	$\delta_{60}$	$\delta_{90}$	$\delta_{120}$
		[N/mm <sup>2</sup> ]	-	[N]	[mm]	[min]	[mm]	[mm]	[mm]	[mm]
		5	0.5	137.27	9.99	120.00	9.99	9.99	9.99	9.99
		10	0.5	276.84	11.75	120.00	11.75	11.75	11.75	11.75
		15	0.5	416.42	15.86	63.33	14.16	15.28	63.03	121.65
		20	0.5	555.99	22.39	33.33	18.20	69.87	152.09	152.22
		25	0.5	695.57	18.42	26.67	61.00	151.91	-	-
		30	0.5	835.14	18.09	23.34	-	-	-	-
		5	0.5	137.27	10.15	120.00	10.15	10.15	10.15	10.15
		10	0.5	276.84	12.01	120.00	12.01	12.01	12.01	12.01
		15	0.5	416.42	13.83	55.00	14.77	35.75	152.09	-
		20	0.5	555.99	16.79	28.34	34.83	-	-	-
		25	0.5	695.57	10.20	21.67	55.63	-	-	-
		30	0.5	835.14	8.80	20.01	-	-	-	-
		5	0.67	102.95	10.34	120.00	10.34	10.34	10.34	10.34
		10	0.67	207.63	13.62	120.00	12.86	12.86	12.86	13.62
		15	0.67	312.31	29.55	120.00	16.42	17.49	26.28	29.55
		20	0.67	416.99	38.66	85.00	22.31	28.51	-	-
		25	0.67	521.68	38.73	58.33	30.58	-	-	-
		30	0.67	626.36	43.80	33.33	40.58	-	-	-
		5	0.67	102.95	10.53	120.00	10.53	10.53	10.53	10.53
		10	0.67	207.63	16.24	120.00	13.31	13.31	14.69	16.24
		15	0.67	312.31	31.42	73.33	17.59	22.19	66.63	74.91
		20	0.67	416.99	36.22	40.00	25.58	69.87	-	-
		25	0.67	521.68	29.51	26.67	67.64	-	-	-
		30	0.67	626.36	15.59	21.67	-	-	-	-

<sup>13)</sup> Momentum degree of fullness without contribution from channel dead weight

<sup>14)</sup> Size of the designated system's single load

List of symbols see Annex D3

Hilti installation channel MQ-41-L

Annex D15

Deformation at elevated temperatures

Table D16: Calculation-based deformation at elevated temperatures for installation channel MQ-41-L

System [Dimensions in mm]	Load direction	$\sigma_B$	$V^{13)}$	$F^{14)}$	$\delta_{tmax,B}$	$t_{max,B}$	$\delta_{30}$	$\delta_{60}$	$\delta_{90}$	$\delta_{120}$
		[N/mm <sup>2</sup> ]	-	[N]	[mm]	[min]	[mm]	[mm]	[mm]	[mm]
		5	0.5	79.90	10.95	120.00	10.95	10.95	10.95	10.95
		10	0.5	163.65	26.35	120.00	15.87	15.95	24.25	26.35
		15	0.5	247.39	73.01	111.67	22.77	36.92	63.03	121.65
		20	0.5	331.14	71.90	61.67	35.02	69.87	201.48	220.73
		25	0.5	414.88	74.45	33.33	61.00	196.71	-	-
		30	0.5	498.63	18.72	21.67	-	-	-	-
		5	0.5	79.90	11.04	120.00	11.04	11.04	11.04	11.04
		10	0.5	163.65	26.71	120.00	16.04	16.40	24.60	26.71
		15	0.5	247.39	61.00	88.33	23.10	35.75	226.49	-
		20	0.5	331.14	62.72	53.33	34.83	-	-	-
		25	0.5	414.88	55.64	30.00	55.63	-	-	-
		30	0.5	498.63	52.94	25.00	-	-	-	-
		5	0.80	99.88	12.38	120.00	12.38	12.38	12.38	12.38
		10	0.80	204.56	43.96	93.33	20.52	27.36	42.80	-
		15	0.80	309.24	48.11	40.00	34.56	-	-	-
		20	0.80	413.92	39.52	25.00	-	-	-	-
		25	0.80	518.60	25.70	21.67	-	-	-	-
		30	0.80	623.28	17.19	20.01	-	-	-	-
		5	0.80	99.88	12.57	120.00	12.57	12.57	12.57	12.57
		10	0.80	204.56	43.79	120.00	20.93	27.66	40.11	43.79
		15	0.80	309.24	74.91	120.00	33.22	50.04	66.63	74.91
		20	0.80	413.92	71.07	61.67	50.28	69.87	-	-
		25	0.80	518.60	73.46	33.33	67.64	-	-	-
		30	0.80	623.28	32.67	21.67	-	-	-	-
		5	0.67	33.29	11.78	120.00	11.78	11.78	11.78	11.78
		10	0.67	68.19	35.63	120.00	18.46	21.99	32.61	35.63
		15	0.67	103.08	68.05	120.00	27.9	42.41	59.85	68.05
		20	0.67	137.97	97.11	108.33	42.42	63.00	86.84	132.76
		25	0.67	172.87	92.57	68.33	59.58	83.73	144.49	193.82
		30	0.67	207.76	92.59	43.33	77.67	135.12	199.59	221.04
		5	0.67	33.29	11.90	120.00	11.90	11.90	11.90	11.90
		10	0.67	68.19	37.75	120.00	18.89	23.36	34.73	37.75
		15	0.67	103.08	84.65	120.00	29.06	46.15	67.36	84.65
		20	0.67	137.97	85.76	71.67	45.24	73.06	177.08	242.63
		25	0.67	172.87	87.88	43.33	67.22	173.43	-	-
		30	0.67	207.76	26.73	21.67	-	-	-	-

<sup>13)</sup> Momentum degree of fullness without contribution from channel dead weight

<sup>14)</sup> Size of the designated system's single load

List of symbols see Annex D3

Hilti installation channel MQ-41-L

Annex D16

Deformation at elevated temperatures

Table D17: Calculation-based deformation at elevated temperatures for installation channel MQ-41-L

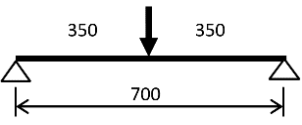
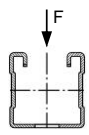
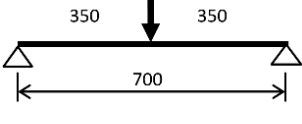
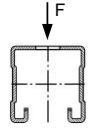
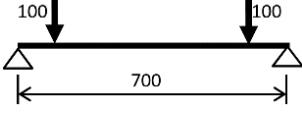
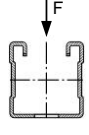
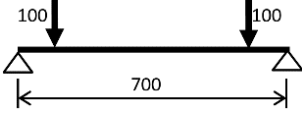
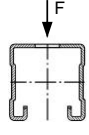
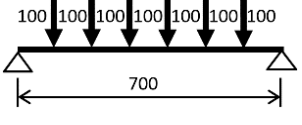
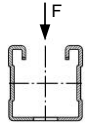
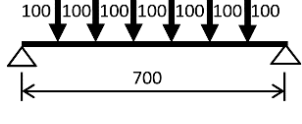
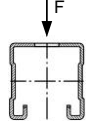
System [Dimensions in mm]	Load direction	$\sigma_B$	$V^{(13)}$	$F^{(14)}$	$\delta_{t_{max},B}$	$t_{max,B}$	$\delta_{30}$	$\delta_{60}$	$\delta_{90}$	$\delta_{120}$
		[N/mm <sup>2</sup> ]	-	[N]	[mm]	[min]	[mm]	[mm]	[mm]	[mm]
		5	0.5	54.44	12.36	120.00	12.36	12.36	12.36	12.36
		10	0.5	114.26	51.65	120.00	21.98	31.32	47.25	51.65
		15	0.5	174.07	121.65	120.00	35.56	67.76	104.96	121.65
		20	0.5	233.89	141.35	83.33	58.66	111.80	201.48	220.73
		25	0.5	293.71	133.40	50.00	99.30	196.71	-	-
		30	0.5	353.53	30.57	21.67	-	-	-	-
		5	0.5	54.44	12.48	120.00	12.48	12.48	12.48	12.48
		10	0.5	114.26	50.68	120.00	22.27	31.66	46.74	50.68
		15	0.5	174.07	101.13	86.67	35.87	64.12	226.49	-
		20	0.5	233.89	98.67	51.67	56.99	-	-	-
		25	0.5	293.71	93.66	30.00	93.64	-	-	-
		30	0.5	353.53	68.20	23.34	-	-	-	-
		5	0.86	95.27	17.01	120.00	15.30	15.30	16.35	17.01
		10	0.86	199.95	53.87	65.00	31.09	50.12	-	-
		15	0.86	304.63	52.31	28.34	-	-	-	-
		20	0.86	409.31	25.86	21.67	-	-	-	-
		25	0.86	513.99	19.34	20.01	-	-	-	-
		30	0.86	618.67	15.07	18.34	-	-	-	-
		5	0.86	95.27	16.90	120.00	15.55	15.55	16.35	16.90
		10	0.86	199.95	71.55	120.00	31.94	49.35	66.24	71.55
		15	0.86	304.63	102.82	120.00	52.49	75.56	94.61	102.82
		20	0.86	409.31	99.17	63.33	74.46	96.68	-	-
		25	0.86	513.99	99.97	35.00	92.12	-	-	-
		30	0.86	618.67	53.21	21.67	-	-	-	-
		5	0.67	15.88	14.08	120.00	14.08	14.08	14.08	14.08
		10	0.67	33.32	61.97	120.00	26.90	40.45	57.00	61.97
		15	0.67	50.77	99.67	120.00	43.72	68.48	90.07	99.67
		20	0.67	68.22	132.76	120.00	65.24	93.02	118.25	132.76
		25	0.67	85.66	151.80	101.67	86.33	114.31	144.49	193.82
		30	0.67	103.11	145.11	68.33	105.62	135.12	199.59	221.04
		5	0.67	15.88	14.18	120.00	14.18	14.18	14.18	14.18
		10	0.67	33.32	66.15	120.00	27.65	43.13	61.06	66.15
		15	0.67	50.77	112.02	120.00	45.99	74.75	99.34	112.02
		20	0.67	68.22	139.09	88.33	70.40	104.22	177.08	242.63
		25	0.67	85.66	135.37	58.33	95.91	173.43	-	-
		30	0.67	103.11	44.21	21.67	-	-	-	-

<sup>13)</sup> Momentum degree of fullness without contribution from channel dead weight

<sup>14)</sup> Size of the designated system's single load

List of symbols see Annex D3

Hilti installation channel MQ-41-L

Annex D17

Deformation at elevated temperatures

Table D18: Calculation-based deformation at elevated temperatures for installation channel MQ-41-L

System [Dimensions in mm]	Load direction	$\sigma_B$	$V^{13)}$	$F^{14)}$	$\bar{\delta}_{t_{max};B}$	$t_{max,B}$	$\bar{\delta}_{30}$	$\bar{\delta}_{60}$	$\bar{\delta}_{90}$	$\bar{\delta}_{120}$
		[N/mm <sup>2</sup> ]	-	[N]	[mm]	[min]	[mm]	[mm]	[mm]	[mm]
		5	0.5	39.61	14.39	120.00	14.39	14.39	14.39	14.39
		10	0.5	86.13	80.97	120.00	30.31	50.69	74.06	80.97
		15	0.5	132.66	171.66	120.00	51.70	101.41	150.76	171.66
		20	0.5	179.18	220.73	120.00	85.69	158.7	201.48	220.73
		25	0.5	225.71	224.25	76.67	139.47	196.71	-	-
		30	0.5	272.23	45.73	21.67	-	-	-	-
		5	0.5	39.61	14.56	120.00	14.56	14.56	14.56	14.56
		10	0.5	86.13	80.27	120.00	30.82	51.52	74.01	80.27
		15	0.5	132.66	140.18	85.00	52.73	96.30	226.49	-
		20	0.5	179.18	137.20	50.00	83.88	-	-	-
		25	0.5	225.71	116.09	28.34	-	-	-	-
		30	0.5	272.23	47.12	21.67	-	-	-	-
		5	0.89	89.12	32.32	120.00	19.05	21.75	30.48	32.32
		10	0.89	193.80	67.26	51.67	46.67	-	-	-
		15	0.89	298.48	21.82	21.67	-	-	-	-
		20	0.89	403.16	18.11	20.01	-	-	-	-
		25	0.89	507.84	15.24	18.34	-	-	-	-
		30	0.89	612.52	25.19	18.34	-	-	-	-
		5	0.89	89.12	26.31	120.00	19.31	21.16	25.47	26.31
		10	0.89	193.80	97.23	120.00	45.31	71.20	90.74	97.23
		15	0.89	298.48	132.36	120.00	72.27	100.77	123.03	132.36
		20	0.89	403.16	128.84	66.67	97.26	123.18	-	-
		25	0.89	507.84	126.62	36.67	116.29	-	-	-
		30	0.89	612.52	118.56	26.67	-	-	-	-
		5	0.67	8.91	20.54	120.00	17.40	17.40	19.78	20.54
		10	0.67	19.38	89.80	120.00	38.11	61.80	83.02	89.80
		15	0.67	29.85	131.42	120.00	62.44	94.92	120.43	131.42
		20	0.67	40.32	164.59	120.00	89.00	122.22	149.97	164.59
		25	0.67	50.78	193.82	120.00	112.32	145.10	175.88	193.82
		30	0.67	61.25	221.04	120.00	132.59	165.24	199.59	221.04
		5	0.67	8.91	20.85	120.00	17.44	17.44	20.10	20.85
		10	0.67	19.38	97.51	120.00	39.44	66.63	90.25	97.51
		15	0.67	29.85	147.48	120.00	66.73	104.99	133.86	147.48
		20	0.67	40.32	197.74	115.00	97.67	138.76	177.08	242.63
		25	0.67	50.78	188.91	70.00	126.55	173.43	-	-
		30	0.67	61.25	31.61	20.01	-	-	-	-

<sup>13)</sup> Momentum degree of fullness without contribution from channel dead weight

<sup>14)</sup> Size of the designated system's single load

List of symbols see Annex D3

Hilti installation channel MQ-41-L	Annex D18
Deformation at elevated temperatures	

Table D19: Calculation-based deformation at elevated temperatures for installation channel MQ-41-L

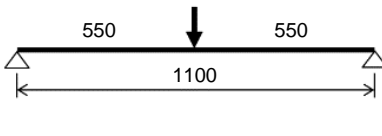
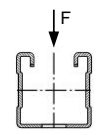
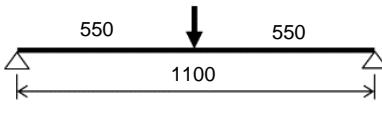
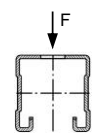
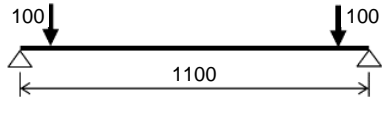
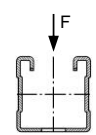
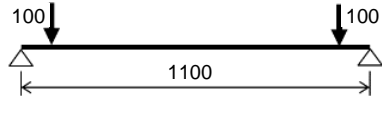
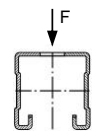
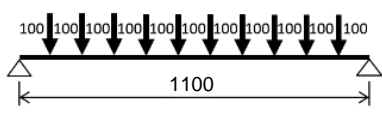
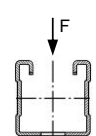
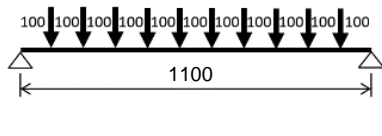
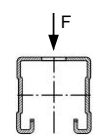
System [Dimensions in mm]	Load-direction	$\sigma_B$	$V^{13)}$	$F^{14)}$	$\delta_{t_{max},B}$	$t_{max,B}$	$\delta_{30}$	$\delta_{60}$	$\delta_{90}$	$\delta_{120}$
		[N/mm <sup>2</sup> ]	-	[N]	[mm]	[min]	[mm]	[mm]	[mm]	[mm]
		5	0.5	29.61	17.10	120.00	17.10	17.10	17.10	17.10
		10	0.5	67.68	115.26	120.00	40.78	73.38	104.69	115.26
		15	0.5	105.74	225.59	120.00	70.87	141.32	200.98	225.59
		20	0.5	143.81	284.53	120.00	118.42	210.19	262.44	284.53
		25	0.5	181.87	42.77	21.67	-	-	-	-
		30	0.5	219.94	29.22	20.01	-	-	-	-
		5	0.5	29.61	17.75	120.00	17.36	17.36	17.36	17.75
		10	0.5	67.68	114.21	120.00	41.76	75.23	105.17	114.21
		15	0.5	105.74	180.58	80.00	73.22	131.60	226.49	-
		20	0.5	143.81	174.67	45.00	114.31	-	-	-
		25	0.5	181.87	129.85	26.67	-	-	-	-
		30	0.5	219.94	30.80	20.01	-	-	-	-
		5	0.91	81.43	50.88	120.00	23.53	34.34	47.63	50.88
		10	0.91	186.11	82.29	45.00	64.82	-	-	-
		15	0.91	290.79	30.45	21.67	-	-	-	-
		20	0.91	395.47	25.78	20.01	-	-	-	-
		25	0.91	500.15	20.81	18.34	-	-	-	-
		30	0.91	604.84	17.28	16.67	-	-	-	-
		5	0.91	81.43	36.31	120.00	23.70	29.74	35.12	36.31
		10	0.91	186.11	123.00	120.00	60.30	93.24	115.30	123.00
		15	0.91	290.79	162.89	120.00	92.72	127.1	152.20	162.89
		20	0.91	395.47	159.48	68.33	120.22	151.51	-	-
		25	0.91	500.15	156.33	40.00	141.31	-	-	-
		30	0.91	604.84	150.71	28.34	-	-	-	-
		5	0.67	5.43	32.93	120.00	21.91	25.88	31.77	32.93
		10	0.67	12.41	118.11	120.00	51.85	84.58	109.55	118.11
		15	0.67	19.39	164.18	120.00	82.90	121.75	151.34	164.18
		20	0.67	26.36	197.93	120.00	113.14	151.16	182.27	197.93
		25	0.67	33.34	227.19	120.00	138.33	175.94	209.05	227.19
		30	0.67	40.32	253.24	120.00	159.81	197.23	232.73	253.24
		5	0.67	5.43	32.74	120.00	21.76	25.81	31.58	32.74
		10	0.67	12.41	129.81	120.00	53.93	92.10	120.39	129.81
		15	0.67	19.39	185.84	120.00	89.59	135.91	169.98	185.84
		20	0.67	26.36	242.63	120.00	125.82	174.11	215.99	242.63
		25	0.67	33.34	232.07	71.67	157.76	211.73	-	-
		30	0.67	40.32	44.07	20.01	-	-	-	-

<sup>13)</sup> Momentum degree of fullness without contribution from channel dead weight

<sup>14)</sup> Size of the designated system's single load

List of symbols see Annex D3

Hilti installation channel MQ-41-L

Annex D19

Deformation at elevated temperatures

English translation prepared by DIBt

Table D20: Calculation-based deformation at elevated temperatures for installation channel MQ-41-L

System [Dimensions in mm]	Load-direction	$\sigma_B$	$V^{13)}$	$F^{14)}$	$\bar{\delta}_{t_{max},B}$	$t_{max,B}$	$\bar{\delta}_{30}$	$\bar{\delta}_{60}$	$\bar{\delta}_{90}$	$\bar{\delta}_{120}$
		[N/mm <sup>2</sup> ]	-	[N]	[mm]	[min]	[mm]	[mm]	[mm]	[mm]
		5	0.5	22.22	24.40	120.00	20.62	20.62	23.18	24.40
		10	0.5	54.43	155.81	120.00	53.44	98.96	138.88	155.81
		15	0.5	86.64	280.67	120.00	92.97	183.12	251.92	280.67
		20	0.5	118.85	351.34	120.00	156.53	262.70	326.19	351.34
		25	0.5	151.06	56.74	21.67	-	-	-	-
		30	0.5	183.27	86.73	21.67	-	-	-	-
		5	0.5	22.22	25.01	120.00	20.68	20.68	23.77	25.01
		10	0.5	54.43	145.27	120.00	54.01	99.39	134.74	145.27
		15	0.5	86.64	239.64	100.00	93.97	162.04	226.49	-
		20	0.5	118.85	227.48	55.00	140.92	-	-	-
		25	0.5	151.06	57.97	21.67	-	-	-	-
		30	0.5	183.27	85.95	21.67	-	-	-	-
		5	0.92	72.21	64.86	120.00	28.97	48.13	61.09	64.86
		10	0.92	176.89	20.07	21.67	-	-	-	-
		15	0.92	281.57	18.16	20.01	-	-	-	-
		20	0.92	386.25	17.42	18.34	-	-	-	-
		25	0.92	490.93	16.95	16.67	-	-	-	-
		30	0.92	595.61	23.07	16.67	-	-	-	-
		5	0.92	72.21	46.99	120.00	28.62	38.89	45.39	46.99
		10	0.92	176.89	150.29	120.00	76.60	116.00	141.07	150.29
		15	0.92	281.57	195.60	120.00	114.30	154.58	183.13	195.60
		20	0.92	386.25	194.74	71.67	144.30	182.05	-	-
		25	0.92	490.93	186.81	41.67	167.60	-	-	-
		30	0.92	595.61	177.80	28.34	-	-	-	-
		5	0.67	3.44	49.33	120.00	27.93	38.58	47.61	49.33
		10	0.67	8.42	146.86	120.00	67.87	108.20	136.41	146.86
		15	0.67	13.41	197.59	120.00	104.63	149.12	182.54	197.59
		20	0.67	18.39	233.73	120.00	137.66	180.52	215.95	233.73
		25	0.67	23.38	263.37	120.00	170.28	213.03	243.60	263.37
		30	0.67	28.36	290.53	120.00	187.73	230.21	268.82	290.53
		5	0.67	3.44	46.77	120.00	27.02	36.96	45.19	46.77
		10	0.67	8.42	159.31	120.00	69.93	117.04	148.59	159.31
		15	0.67	13.41	218.58	120.00	112.04	164.69	202.29	218.58
		20	0.67	18.39	266.02	120.00	151.36	204.02	244.90	266.02
		25	0.67	23.38	268.40	73.33	187.15	246.92	-	-
		30	0.67	28.36	111.20	21.67	-	-	-	-

<sup>13)</sup> Momentum degree of fullness without contribution from channel dead weight

<sup>14)</sup> Size of the designated system's single load

List of symbols see Annex D3

Hilti installation channel MQ-41-L

Annex D20

Deformation at elevated temperatures

Table D21: Calculation-based deformation at elevated temperatures for installation channel MQ-21.5

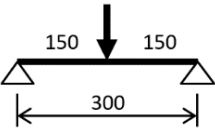
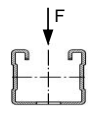
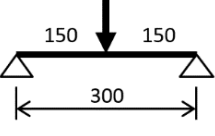
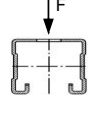
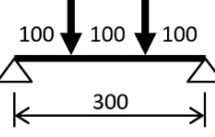
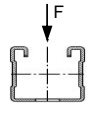
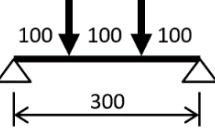
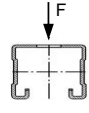
System [Dimensions in mm]	Load direction	$\sigma_B$	$V^{13)}$	$F^{14)}$	$\delta_{t_{max},B}$	$t_{max,B}$	$\delta_{30}$	$\delta_{60}$	$\delta_{90}$	$\delta_{120}$
		[N/mm <sup>2</sup> ]	-	[N]	[mm]	[min]	[mm]	[mm]	[mm]	[mm]
		5	0.5	50.93	35.90	120.00	0.78	16.18	35.66	35.90
		10	0.5	103.51	41.97	120.00	2.41	20.30	41.48	41.97
		15	0.5	156.08	50.47	120.00	4.17	25.12	48.98	50.47
		20	0.5	208.66	63.64	120.00	6.62	31.73	59.30	63.64
		25	0.5	261.24	74.39	120.00	9.74	38.50	68.40	74.39
		30	0.5	313.82	83.86	120.00	13.10	44.68	76.57	83.86
		5	0.5	50.93	36.31	120.00	0.93	16.52	36.05	36.31
		10	0.5	103.51	43.42	120.00	2.77	21.19	42.80	43.42
		15	0.5	156.08	54.41	120.00	4.88	27.04	52.11	54.41
		20	0.5	208.66	70.06	120.00	7.75	34.64	64.27	70.06
		25	0.5	261.24	82.33	113.33	11.45	42.65	75.48	120.75
		30	0.5	313.82	81.67	86.67	16.13	50.45	124.59	137.97
		5	0.67	38.2	36.89	120.00	1.17	17.05	36.62	36.89
		10	0.67	77.63	45.83	120.00	3.31	22.57	44.97	45.83
		15	0.67	117.06	58.77	120.00	5.82	29.52	55.58	58.77
		20	0.67	156.5	71.53	120.00	9.62	37.44	66.21	71.53
		25	0.67	195.93	81.04	120.00	13.74	44.38	74.82	81.04
		30	0.67	235.36	89.52	120.00	19.59	50.50	82.16	89.52
		5	0.67	38.2	37.36	120.00	1.35	17.44	37.07	37.36
		10	0.67	77.63	47.56	120.00	3.75	23.70	46.61	47.56
		15	0.67	117.06	62.66	120.00	6.71	31.95	59.10	62.66
		20	0.67	156.5	77.13	120.00	11.11	41.12	71.29	77.13
		25	0.67	195.93	87.84	120.00	15.97	49.17	80.99	87.84
		30	0.67	235.36	96.75	120.00	23.04	56.32	89.43	96.75

<sup>13)</sup> Momentum degree of fullness without contribution from channel dead weight

<sup>14)</sup> Size of the designated system's single load

List of symbols see Annex D3

Hilti installation channel MQ-21.5

Annex D21

Deformation at elevated temperatures



Table D22: Calculation-based deformation at elevated temperatures for installation channel MQ-21.5

System [Dimensions in mm]	Load direction	$\sigma_B$	$V^{13)}$	$F^{14)}$	$\delta_{t_{max},B}$	$t_{max,B}$	$\delta_{30}$	$\delta_{60}$	$\delta_{90}$	$\delta_{120}$
		[N/mm <sup>2</sup> ]	-	[N]	[mm]	[min]	[mm]	[mm]	[mm]	[mm]
		5	0.5	28.80	38.56	120	2.27	18.42	38.12	38.56
		10	0.5	60.35	55.26	120	6.78	29.72	54.09	55.26
		15	0.5	91.89	75.41	120	11.65	42.14	71.81	75.41
		20	0.5	123.44	96.70	120	18.46	55.66	89.49	96.70
		25	0.5	154.99	113.39	120	26.10	67.52	103.94	113.39
		30	0.5	186.53	128.30	120	34.30	77.91	116.97	128.3
		5	0.5	28.80	38.97	120	2.42	18.77	38.51	38.97
		10	0.5	60.35	56.87	120	7.15	30.70	55.57	56.87
		15	0.5	91.89	79.20	120	12.45	44.18	74.89	79.20
		20	0.5	123.44	102.39	120	19.77	58.6	93.99	102.39
		25	0.5	154.99	120.75	120	27.99	71.25	109.85	120.75
		30	0.5	186.53	137.97	120	37.11	82.73	124.59	137.97
		5	0.80	36.00	42.70	120	3.89	22.04	42.14	42.70
		10	0.80	75.43	67.72	120	10.62	38.23	65.44	67.72
		15	0.80	114.86	86.05	120	18.48	52.16	81.68	86.05
		20	0.80	154.30	101.46	120	28.53	64.07	95.19	101.46
		25	0.80	193.73	113.54	120	36.97	73.50	106.03	113.54
		30	0.80	233.16	123.53	120	44.64	81.41	115.08	123.53
		5	0.80	36.00	42.99	120	4.01	22.29	42.41	42.99
		10	0.80	75.43	68.61	120	10.95	39.02	66.35	68.61
		15	0.80	114.86	86.95	120	19.09	53.23	82.73	86.95
		20	0.80	154.30	101.46	120	29.44	65.14	95.76	101.46
		25	0.80	193.73	112.58	120	38.16	74.56	106.11	112.58
		30	0.80	233.16	121.50	120	45.82	82.33	114.61	121.50
		5	0.67	12.00	41.09	120	3.29	20.62	40.56	41.09
		10	0.67	25.14	62.83	120	9.02	34.66	60.92	62.83
		15	0.67	38.29	82.20	120	15.38	47.97	77.85	82.20
		20	0.67	51.43	99.29	120	24.04	60.29	92.53	99.29
		25	0.67	64.58	112.50	120	32.26	70.41	104.25	112.50
		30	0.67	77.72	123.34	120	40.24	79.04	114.13	123.34
		5	0.67	12.00	41.45	120	3.43	20.93	40.92	41.45
		10	0.67	25.14	65.08	120	9.53	36.28	63.16	65.08
		15	0.67	38.29	86.83	120	16.61	51.22	82.04	86.83
		20	0.67	51.43	105.54	120	26.14	64.66	98.14	105.54
		25	0.67	64.58	120.13	120	35.15	75.80	111.17	120.13
		30	0.67	77.72	132.38	120	44.49	85.43	122.39	132.38

<sup>13)</sup> Momentum degree of fullness without contribution from channel dead weight

<sup>14)</sup> Size of the designated system's single load

List of symbols see Annex D3

Hilti installation channel MQ-21.5

Annex D22

Deformation at elevated temperatures



Table D23: Calculation-based deformation at elevated temperatures for installation channel MQ-21.5

System [Dimensions in mm]	Load direction	$\sigma_B$	$V^{13)}$	$F^{14)}$	$\delta_{t_{max},B}$	$t_{max,B}$	$\delta_{30}$	$\delta_{60}$	$\delta_{90}$	$\delta_{120}$
		[N/mm <sup>2</sup> ]	-	[N]	[mm]	[min]	[mm]	[mm]	[mm]	[mm]
		5	0.5	18.69	42.87	120	4.66	22.06	42.11	42.87
		10	0.5	41.22	74.36	120	13.52	43.69	72.19	74.36
		15	0.5	63.75	104.04	120	23.00	63.98	98.56	104.04
		20	0.5	86.29	130.51	120	35.11	82.48	121.10	130.51
		25	0.5	108.82	153.08	120	47.32	98.46	140.66	153.08
		30	0.5	131.35	174.34	120	59.20	112.91	159.25	174.34
		5	0.5	18.69	43.40	120	4.84	22.51	42.62	43.40
		10	0.5	41.22	76.38	120	14.02	44.91	74.00	76.38
		15	0.5	63.75	108.46	120	23.97	66.31	102.11	108.46
		20	0.5	86.29	137.93	120	36.79	86.23	126.89	137.93
		25	0.5	108.82	162.90	120	49.70	103.6	148.57	162.9
		30	0.5	131.35	187.15	120	62.72	119.45	169.73	187.15
		5	0.86	32.70	50.60	120	7.76	28.86	49.62	50.60
		10	0.86	72.14	89.24	120	20.84	55.64	85.67	89.24
		15	0.86	111.57	111.23	120	33.73	72.83	105.44	111.23
		20	0.86	151.00	127.15	120	47.68	86.66	120.00	127.15
		25	0.86	190.44	140.99	120	58.93	98.17	132.62	140.99
		30	0.86	229.87	153.09	120	68.00	107.86	143.64	153.09
		5	0.86	32.70	50.88	120	7.91	29.12	49.88	50.88
		10	0.86	72.14	89.61	120	21.25	56.31	86.14	89.61
		15	0.86	111.57	111.33	120	34.31	73.48	105.72	111.33
		20	0.86	151.00	126.48	120	48.23	86.82	119.71	126.48
		25	0.86	190.44	138.61	120	59.41	97.81	131.17	138.61
		30	0.86	229.87	148.70	120	68.43	106.94	140.90	148.70
		5	0.67	5.45	48.50	120	6.85	26.86	47.57	48.50
		10	0.67	12.02	83.79	120	17.68	50.71	80.55	83.79
		15	0.67	18.59	107.65	120	28.74	68.63	101.88	107.65
		20	0.67	25.17	126.88	120	41.79	83.83	118.85	126.88
		25	0.67	31.74	143.21	120	53.33	96.53	133.38	143.21
		30	0.67	38.31	156.98	120	63.07	107.34	145.85	156.98
		5	0.67	5.45	48.87	120	6.96	27.19	47.94	48.87
		10	0.67	12.02	87.69	120	18.60	53.55	84.37	87.69
		15	0.67	18.59	114.39	120	31.05	73.73	108.10	114.39
		20	0.67	25.17	136.65	120	45.66	90.78	127.59	136.65
		25	0.67	31.74	155.27	120	58.34	105.08	144.28	155.27
		30	0.67	38.31	171.28	120	69.47	117.53	158.93	171.28

<sup>13)</sup> Momentum degree of fullness without contribution from channel dead weight

<sup>14)</sup> Size of the designated system's single load

List of symbols see Annex D3

Hilti installation channel MQ-21.5

Annex D23

Deformation at elevated temperatures

Table D24: Calculation-based deformation at elevated temperatures for installation channel MQ-21.5

System [Dimensions in mm]	Load direction	$\sigma_B$	$V^{13)}$	$F^{14)}$	$\delta_{t_{max},B}$	$t_{max,B}$	$\delta_{30}$	$\delta_{60}$	$\delta_{90}$	$\delta_{120}$
		[N/mm <sup>2</sup> ]	-	[N]	[mm]	[min]	[mm]	[mm]	[mm]	[mm]
		5	0.5	12.58	49.30	120	8.15	27.51	48.11	49.30
		10	0.5	30.11	97.00	120	22.72	61.15	93.67	97.00
		15	0.5	47.63	133.93	120	37.51	87.74	126.71	133.93
		20	0.5	65.16	166.00	120	54.52	110.89	154.42	166.00
		25	0.5	82.68	195.66	120	70.96	131.59	180.33	195.66
		30	0.5	100.21	224.81	120	85.93	151.20	206.06	224.81
		5	0.5	12.58	50.15	120	8.43	28.22	48.92	50.15
		10	0.5	30.11	100.38	120	23.50	63.05	96.58	100.38
		15	0.5	47.63	140.68	120	39.17	91.52	132.14	140.68
		20	0.5	65.16	176.76	120	57.49	116.62	162.83	176.76
		25	0.5	82.68	210.43	120	74.93	139.19	191.89	210.43
		30	0.5	100.21	246.64	120	91.48	160.73	222.17	246.64
		5	0.89	28.31	59.71	120	12.57	36.75	58.19	59.71
		10	0.89	67.74	109.76	120	33.00	73.01	105.00	109.76
		15	0.89	107.17	136.23	120	49.91	93.70	128.83	136.23
		20	0.89	146.61	155.10	120	66.20	109.16	146.16	155.10
		25	0.89	186.04	170.24	120	79.48	122.17	160.26	170.24
		30	0.89	225.47	183.31	120	90.35	133.58	172.51	183.31
		5	0.89	28.31	60.01	120	12.81	37.04	58.47	60.01
		10	0.89	67.74	109.90	120	33.61	73.67	105.30	109.90
		15	0.89	107.17	135.71	120	50.61	94.18	128.64	135.71
		20	0.89	146.61	153.73	120	66.66	109.25	145.32	153.73
		25	0.89	186.04	167.79	120	79.68	121.48	158.60	167.79
		30	0.89	225.47	179.25	120	90.29	132.01	169.69	179.25
		5	0.67	2.83	60.12	120	12.26	36.47	58.61	60.12
		10	0.67	6.77	106.43	120	29.17	68.93	101.71	106.43
		15	0.67	10.72	134.39	120	44.68	90.24	126.82	134.39
		20	0.67	14.66	155.11	120	60.88	107.38	145.56	155.11
		25	0.67	18.60	173.28	120	74.92	122.17	161.93	173.28
		30	0.67	22.55	189.33	120	86.68	134.97	176.48	189.33
		5	0.67	2.83	60.06	120	12.17	36.48	58.56	60.06
		10	0.67	6.77	112.27	120	30.64	73.32	107.41	112.27
		15	0.67	10.72	143.63	120	48.42	97.53	135.54	143.63
		20	0.67	14.66	168.45	120	66.87	117.58	157.76	168.45
		25	0.67	18.60	190.50	120	82.58	134.83	177.65	190.50
		30	0.67	22.55	210.11	120	95.88	150.19	195.66	210.11

<sup>13)</sup> Momentum degree of fullness without contribution from channel dead weight

<sup>14)</sup> Size of the designated system's single load

List of symbols see Annex D3

Hilti installation channel MQ-21.5

Annex D24

Deformation at elevated temperatures

English translation prepared by DIBt

Table D25: Calculation-based deformation at elevated temperatures for installation channel MQ-21.5

System [Dimensions in mm]	Load direction	$\sigma_B$	$V^{(13)}$	$F^{(14)}$	$\delta_{t_{max},B}$	$t_{max,B}$	$\delta_{30}$	$\delta_{60}$	$\delta_{90}$	$\delta_{120}$
		[N/mm <sup>2</sup> ]	-	[N]	[mm]	[min]	[mm]	[mm]	[mm]	[mm]
		5	0.5	8.30	58.35	120	12.96	35.24	56.58	58.35
		10	0.5	22.64	121.75	120	34.22	80.87	117.12	121.75
		15	0.5	36.97	165.83	120	54.34	113.17	156.63	165.83
		20	0.5	51.31	203.81	120	75.93	141.19	189.97	203.81
		25	0.5	65.65	241.63	120	96.43	167.46	223.46	241.63
		30	0.5	79.99	279.41	120	114.70	193.19	257.28	279.41
		5	0.5	8.30	59.5	120	13.32	36.14	57.68	59.50
		10	0.5	22.64	126.67	120	35.42	83.71	121.31	126.67
		15	0.5	36.97	173.94	120	56.99	118.18	163.33	173.94
		20	0.5	51.31	216.43	120	80.25	148.38	199.96	216.43
		25	0.5	65.65	259.67	120	101.84	176.81	237.55	259.67
		30	0.5	79.99	306.71	120	121.67	204.71	276.92	306.71
		5	0.91	22.82	69.26	120	18.02	45.01	67.13	69.26
		10	0.91	62.25	130.23	120	46.19	90.30	124.29	130.23
		15	0.91	101.68	161.70	120	66.83	114.64	152.57	161.7
		20	0.91	141.11	184.01	120	84.63	132.70	173.07	184.01
		25	0.91	180.55	201.82	120	99.75	147.39	189.68	201.82
		30	0.91	219.98	216.89	120	112.34	160.17	203.86	216.89
		5	0.91	22.82	68.61	120	17.85	44.48	66.48	68.61
		10	0.91	62.25	130.13	120	46.22	90.65	124.46	130.13
		15	0.91	101.68	160.84	120	67.02	114.88	152.17	160.84
		20	0.91	141.11	182.13	120	84.68	132.58	171.88	182.13
		25	0.91	180.55	198.81	120	99.68	146.72	187.62	198.81
		30	0.91	219.98	212.34	120	111.95	158.70	200.66	212.34
		5	0.67	1.52	76.47	120	19.98	49.77	74.18	76.47
		10	0.67	4.15	129.94	120	43.13	88.32	123.64	129.94
		15	0.67	6.78	161.32	120	62.26	112.41	151.87	161.32
		20	0.67	9.41	184.3	120	80.57	131.16	172.82	184.30
		25	0.67	12.04	203.64	120	96.48	147.46	190.54	203.64
		30	0.67	14.67	221.15	120	110.01	161.97	206.58	221.15
		5	0.67	1.52	75.34	120	19.33	49.06	73.09	75.34
		10	0.67	4.15	137.72	120	45.18	94.29	131.24	137.72
		15	0.67	6.78	173.66	120	67.46	122.15	163.62	173.66
		20	0.67	9.41	201.15	120	88.83	144.74	188.65	201.15
		25	0.67	12.04	225.91	120	107.07	164.77	211.23	225.91
		30	0.67	14.67	248.49	120	122.64	182.8	232.05	248.49

<sup>13)</sup> Momentum degree of fullness without contribution from channel dead weight

<sup>14)</sup> Size of the designated system's single load

List of symbols see Annex D3

Hilti installation channel MQ-21.5

Annex D25

Deformation at elevated temperatures

Table D26: Calculation-based deformation at elevated temperatures for installation channel MQ-21.5

System [Dimensions in mm]	Load direction	$\sigma_B$	$V^{13)}$	$F^{14)}$	$\bar{\delta}_{t_{max},B}$	$t_{max,B}$	$\bar{\delta}_{30}$	$\bar{\delta}_{60}$	$\bar{\delta}_{90}$	$\bar{\delta}_{120}$
		[N/mm <sup>2</sup> ]	-	[N]	[mm]	[min]	[mm]	[mm]	[mm]	[mm]
		5	0.5	4.99	70.37	120	19.34	45.57	67.88	70.37
		10	0.5	17.12	148.28	120	47.84	102.40	142.18	148.28
		15	0.5	29.26	199.68	120	73.17	140.21	188.29	199.68
		20	0.5	41.39	244.11	120	98.98	173.42	227.91	244.11
		25	0.5	53.52	290.84	120	123.4	206.14	269.93	290.84
		30	0.5	65.66	337.33	120	145.42	238.51	312.15	337.33
		5	0.5	4.99	69.03	120	18.76	44.41	66.57	69.03
		10	0.5	17.12	148.92	120	47.55	102.68	142.83	148.92
		15	0.5	29.26	201.38	120	73.31	141.42	190.02	201.38
		20	0.5	41.39	245.28	120	99.88	175.08	229.31	245.28
		25	0.5	53.52	292.46	120	124.89	208.20	271.64	292.46
		30	0.5	65.66	338.82	120	147.19	240.38	313.45	338.82
		5	0.92	16.22	78.87	120	23.79	53.24	76.05	78.87
		10	0.92	55.66	151.53	120	59.88	107.99	144.35	151.53
		15	0.92	95.09	188.56	120	84.35	136.35	177.57	188.56
		20	0.92	134.52	214.56	120	103.59	157.21	201.46	214.56
		25	0.92	173.96	235.27	120	120.49	174.14	220.79	235.27
		30	0.92	213.39	252.73	120	134.83	188.67	237.23	252.73
		5	0.92	16.22	78.02	120	23.41	52.52	75.22	78.02
		10	0.92	55.66	152.1	120	59.93	108.82	145.22	152.10
		15	0.92	95.09	188.14	120	84.74	136.95	177.70	188.14
		20	0.92	134.52	212.89	120	103.82	157.33	200.59	212.89
		25	0.92	173.96	232.30	120	120.54	173.71	218.88	232.30
		30	0.92	213.39	248.10	120	134.54	187.49	234.07	248.10
		5	0.67	0.77	96.8	120	30.36	66.32	93.51	96.80
		10	0.67	2.65	154.08	120	59.03	108.42	146.12	154.08
		15	0.67	4.53	188.24	120	80.96	134.78	176.91	188.24
		20	0.67	6.41	213.68	120	100.64	155.24	200.14	213.68
		25	0.67	8.28	234.66	120	117.97	172.76	219.49	234.66
		30	0.67	10.16	253.24	120	132.93	188.58	236.72	253.24
		5	0.67	0.77	91.15	120	27.59	62.56	88.13	91.15
		10	0.67	2.65	160.32	120	59.87	113.66	152.69	160.32
		15	0.67	4.53	200.42	120	84.98	144.67	188.89	200.42
		20	0.67	6.41	230.68	120	108.25	169.16	216.69	230.68
		25	0.67	8.28	256.84	120	128.54	191.19	241.02	256.84
		30	0.67	10.16	281.15	120	146.18	211.36	263.61	281.15

<sup>13)</sup> Momentum degree of fullness without contribution from channel dead weight

<sup>14)</sup> Size of the designated system's single load

List of symbols see Annex D3

Hilti installation channel MQ-21.5

Annex D26

Deformation at elevated temperatures

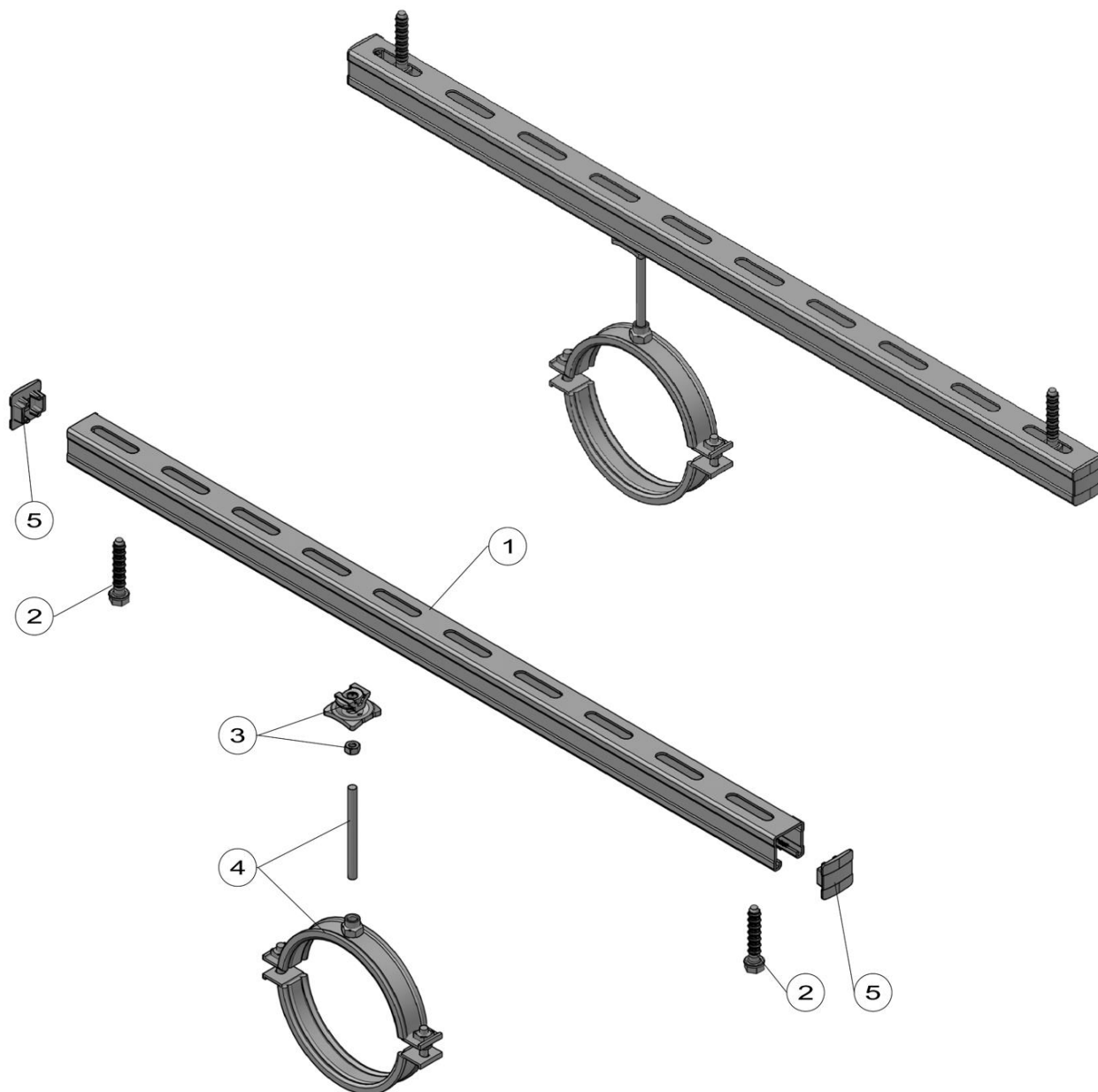

**Legend**

- 1 MQ-41/3 or MQ-41/3 LL
- 2 Fastener to the substructure
- 3 MQA-B with hexagonal nut
- 4 Pipe ring with threaded rod<sup>15)</sup>
- 5 MQZ-E41 end cap

<sup>15)</sup> Number, type and variable pipe ring assignments

**Annex**

- A1 not an integral part of this ETA
- not an integral part of this ETA
- not an integral part of this ETA
- not an integral part of this ETA

Hilti installation channel MQ-41/3 and Hilti installation channel MQ-41/3 LL

Headrail installation: Fixation in the back of the channel for use at ambient temperature applications

Annex E1  
(informative)

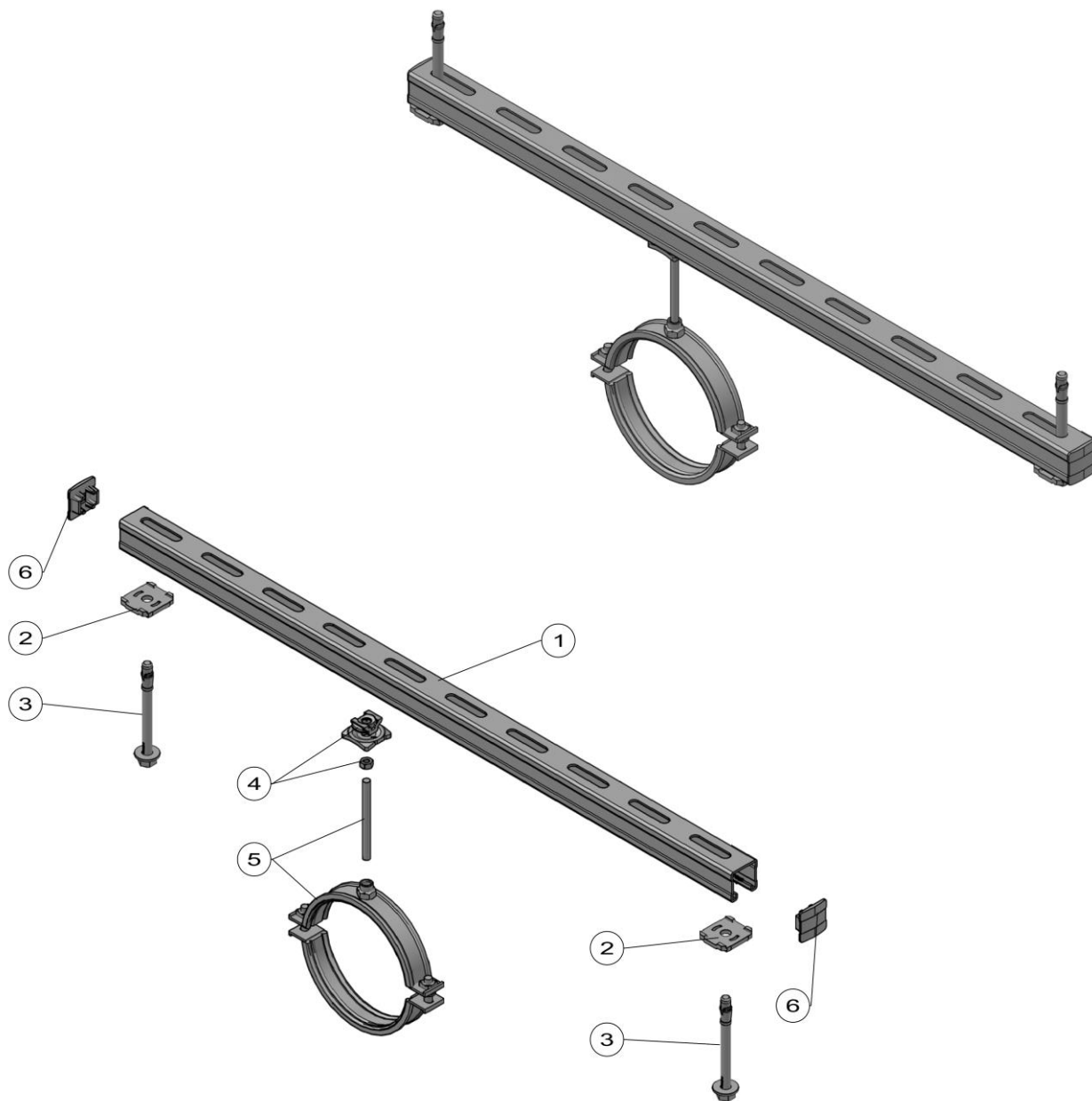

**Legend**

- 1 MQ-41/3 or MQ-41/3 LL
- 2 MQZ-L drilled plate
- 3 Fastener to the substructure
- 4 MQA-B with hexagonal nut
- 5 Pipe ring with threaded rod<sup>15)</sup>
- 6 MQZ-E41 end cap

<sup>15)</sup> Number, type and variable pipe ring assignments

**Annex**

- A1 not an integral part of this ETA
- not an integral part of this ETA
- not an integral part of this ETA
- not an integral part of this ETA

Hilti installation channel MQ-41/3 and Hilti installation channel MQ-41/3 LL

Headrail installation: Fixation of the channel with MQZ-L drilled plates for use at ambient and elevated temperature applications

Annex E2  
(informative)

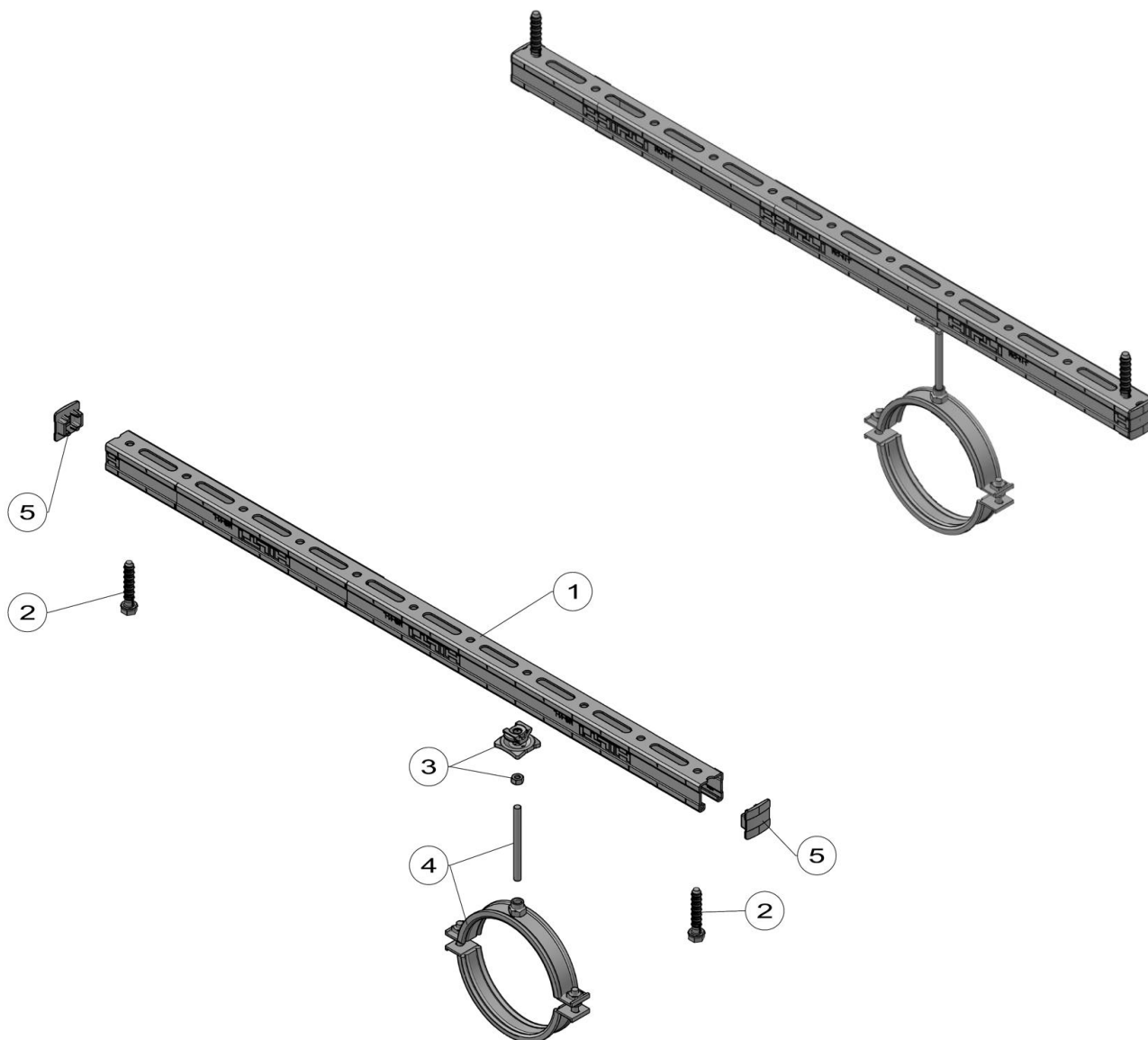

**Legend**

- 1 MQ-41, MQ-41-L or MQ-21.5
- 2 Fastener to the substructure
- 3 MQA-B with hexagonal nut
- 5 Pipe ring with threaded rod<sup>15)</sup>
- 6 MQZ-E41 or MQZ-E21 end cap

<sup>15)</sup> Number, type and variable pipe ring assignments

**Annex**

- A2 not an integral part of this ETA
- not an integral part of this ETA
- not an integral part of this ETA
- not an integral part of this ETA

Hilti installation channel MQ-21.5, Hilti installation channel MQ-41 and  
Hilti installation channel MQ-41-L

Headrail installation: Fixation in the back of the channel for use at ambient and elevated  
temperature applications

Annex E3  
(informative)



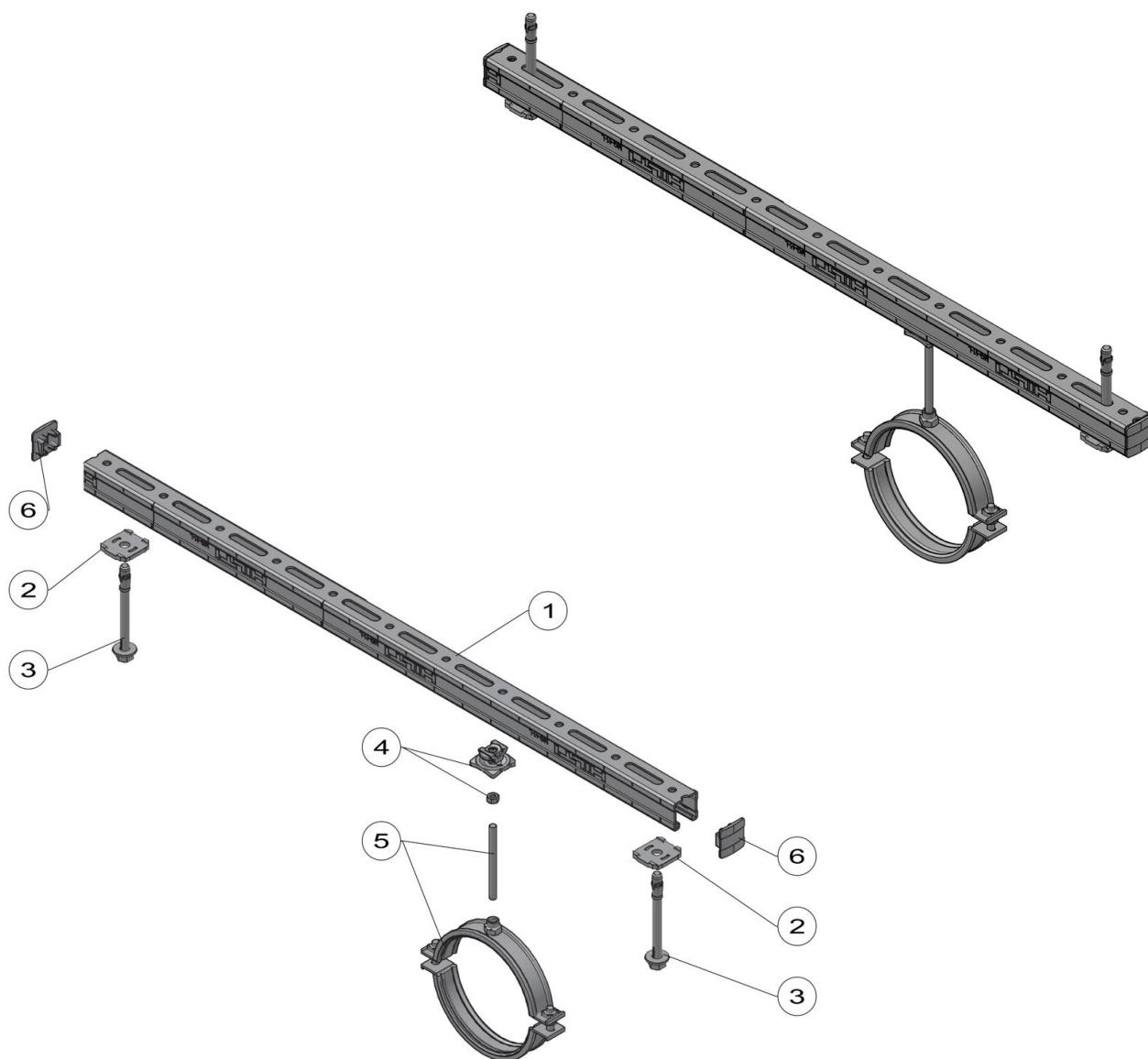

**Legend**

- 1 MQ-41, MQ-41-L or MQ-21.5
- 2 MQZ-L drilled plate
- 3 Fastener to the substructure
- 4 MQA-B with hexagonal nut
- 5 Pipe ring with threaded rod<sup>15)</sup>
- 6 MQZ-E41 or MQZ-E21 end cap

<sup>15)</sup> Number, type and variable pipe ring assignments

**Annex**

- A2
- not an integral part of this ETA
- not an integral part of this ETA
- not an integral part of this ETA
- not an integral part of this ETA

Hilti installation channel MQ-21.5, Hilti installation channel MQ-41 and  
Hilti installation channel MQ-41-L

Headrail installation: Fixation of the channel with MQZ-L drilled plates for use at  
ambient and elevated temperature applications

Annex E4  
(informative)



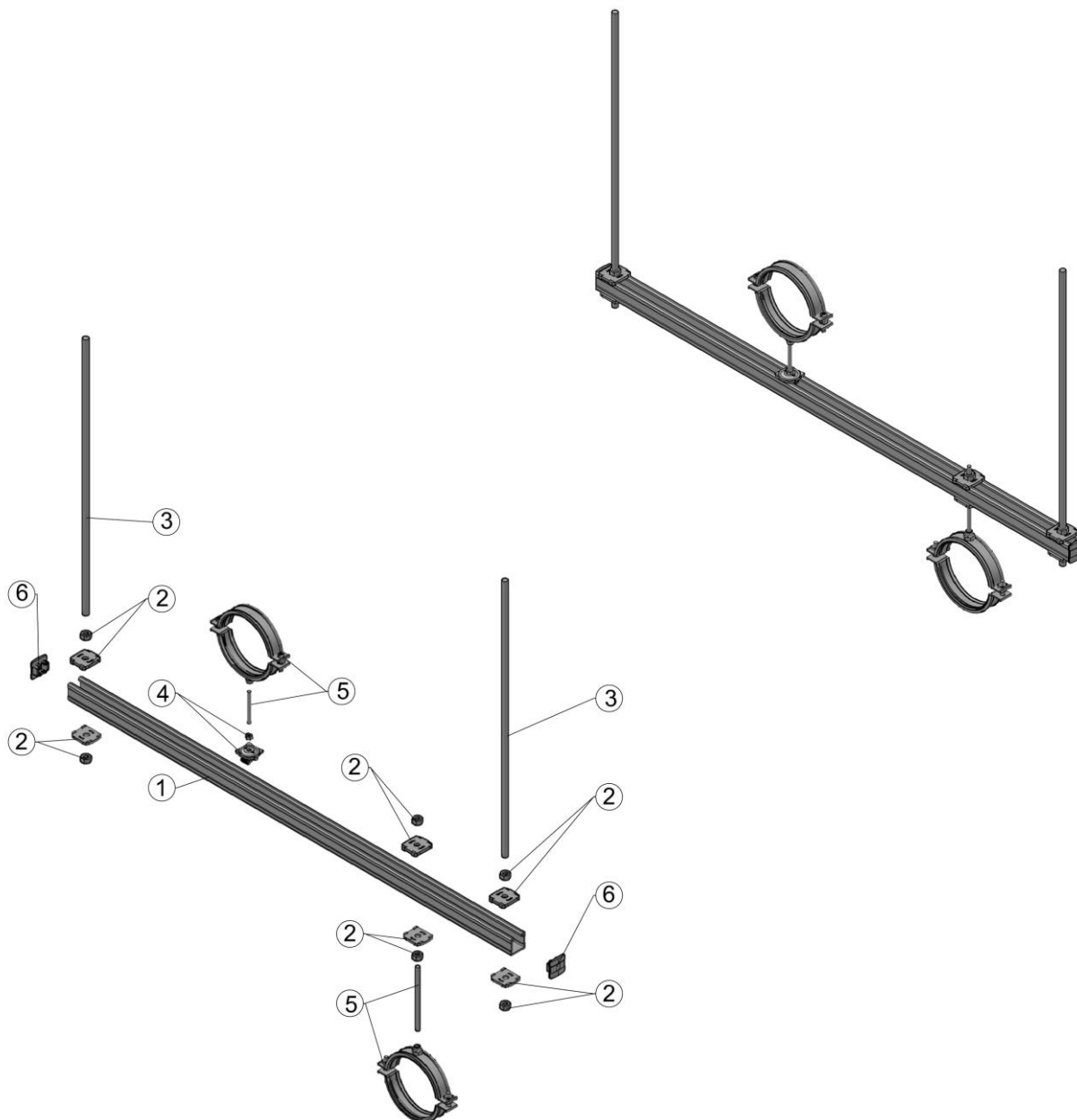

**Legend**

- 1 MQ-41/3, MQ-41/3 LL, MQ-41, MQ-41-L or MQ-21.5
- 2 MQZ-L with hexagonal nut
- 3 Threaded rod
- 4 MQA-B with hexagonal nut
- 5 Pipe ring with threaded rod<sup>15)</sup>
- 6 MQZ-E41 or MQZ-E21 end cap

<sup>15)</sup> Number, type and variable pipe ring assignments

**Annex**

- A1, A2
- not an integral part of this ETA
- not an integral part of this ETA
- not an integral part of this ETA
- not an integral part of this ETA

Hilti installation channel MQ-41/3, Hilti installation channel MQ-41/3 LL,  
Hilti installation channel MQ-21.5, Hilti installation channel MQ-41 and  
Hilti installation channel MQ-41-L

Trapeze rod installation with channel opening at the top

Annex E5  
(informative)

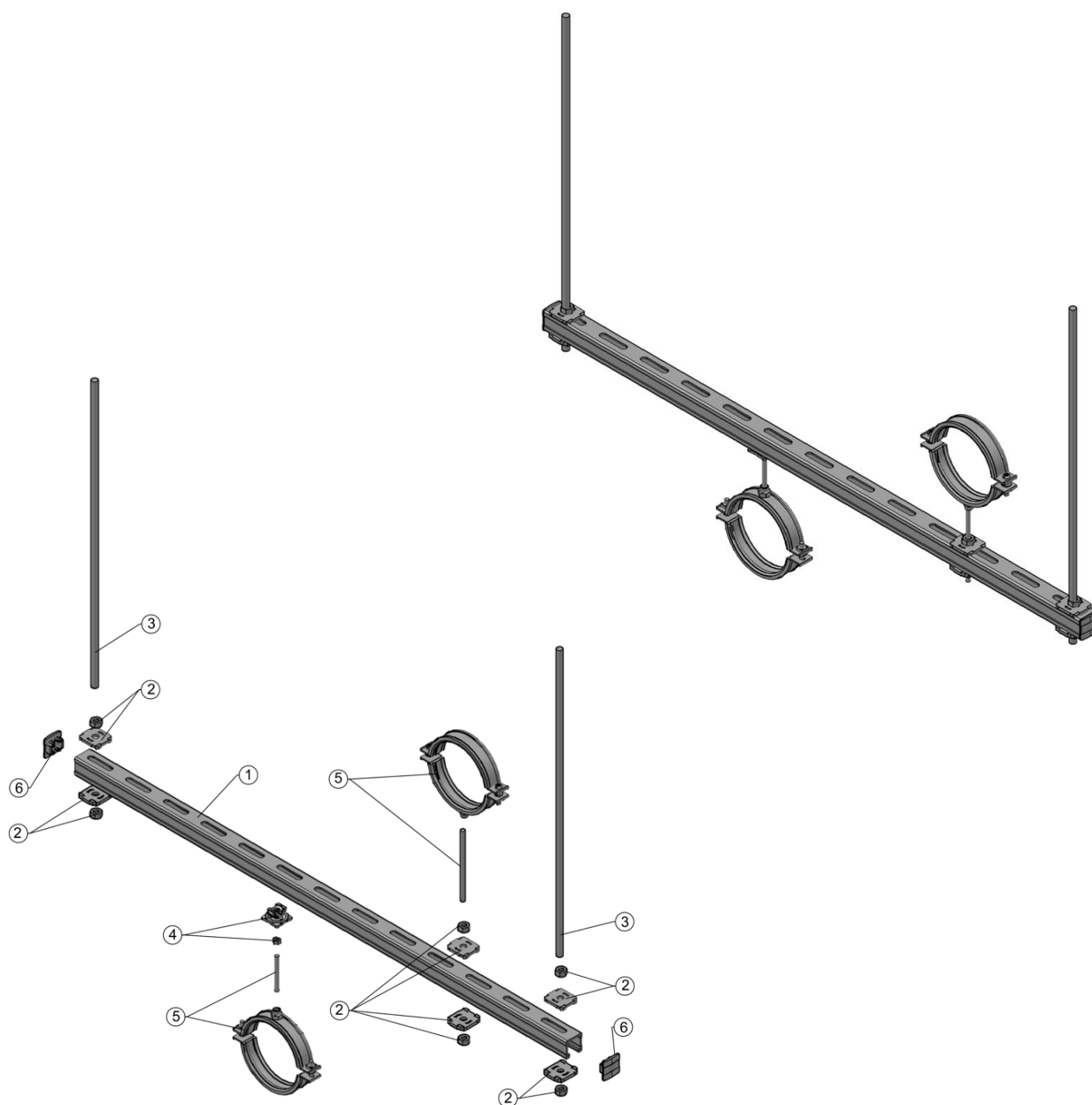

**Legend**

- 1 MQ-41/3, MQ-41/3 LL or MQ-41, MQ-41-L, MQ-21.5
- 2 MQZ-L with hexagonal nut
- 3 Threaded rod
- 4 MQA-B with hexagonal nut
- 5 Pipe ring with threaded rod<sup>15)</sup>
- 6 MQZ-E41 or MQZ-E21 end cap

<sup>15)</sup> Number, type and variable pipe ring assignments

**Annex**

- A1, A2
- not an integral part of this ETA
- not an integral part of this ETA
- not an integral part of this ETA
- not an integral part of this ETA

Hilti installation channel MQ-41/3, Hilti installation channel MQ-41/3 LL,  
Hilti installation channel MQ-21.5, Hilti installation channel MQ-41 and  
Hilti installation channel MQ-41-L

Trapeze rod installation with channel opening underneath

Annex E6  
(informative)

English translation prepared by DIBt

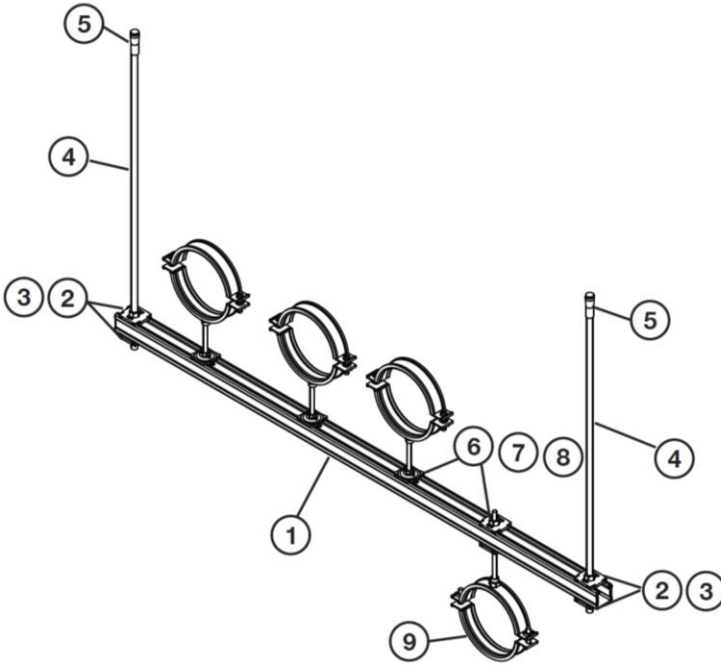

Bill of material / Stückliste				
Part of typical/ Applikationselement	Ref.	Opt.	Item no. / Artikel Nr.	Description / Bezeichnung
Channel / Schiene	1		2184772	MQ-21.5 3m channel*
	1		369596	MQ-41/3 3m channel*
	1		369591	MQ-41 3m channel*
	1		2141965	MQ-41-L 3m channel*
	1		2148102	MQ-41/3-LL 3m channel*
Structure / Aufbau	2	A	2199455	MQZ-L11 drilled plate
	2	B	2199456	MQZ-L13 drilled plate
	3	A	216466	M10 hexagon nut
	3	B	216467	M12 hexagon nut
	4	A	339795	AM10x1000 4.8 threaded rod**
	4	B	339797	AM12x1000 4.8 threaded rod**
	5	A	376967	HKD M10x40 drop-in anchor
	5	B	378544	HKD M12x50 drop-in anchor
Pipe Fixation / Rohr- fixierung	6	A	2199452	MQA-M10-B piping saddle
	6	B	2199455	MQZ-L11 drilled plate
	7		216466	M10 hexagon nut
	8		339795	AM10x1000 4.8 threaded rod**
	6	A	2199453	MQA-M12-B piping saddle
	6	B	2199456	MQZ-L13 drilled plate
	7		216467	M12 hexagon nut
	8		339797	AM12x1000 4.8 threaded rod**
	6		2199454	MQA-M16-B piping saddle
	7		216468	M16 hexagon nut
	8		216422	AM16x1000 4.8 threaded rod**
	Pipe Ring / Rohrschelle	M10/ M12/ M16		20843 - 20898

\* other length of the channels also possible / \* andere Schienenlängen auch möglich  
\*\* Threaded rod available in 1, 2 & 3 meters / Gewindestange erhältlich in 1, 2 & 3 Meter

Assembly Instructions / Montagehinweise

**1**  
Please use the Threaded rod & Anchors either in closed long holes or closed round holes in the channel  
Verwendung von Gewindestangen und Dübeln nur durch geschlossene Langlöcher bzw. Rundlöcher der Schiene

**2 / 3 / 4**

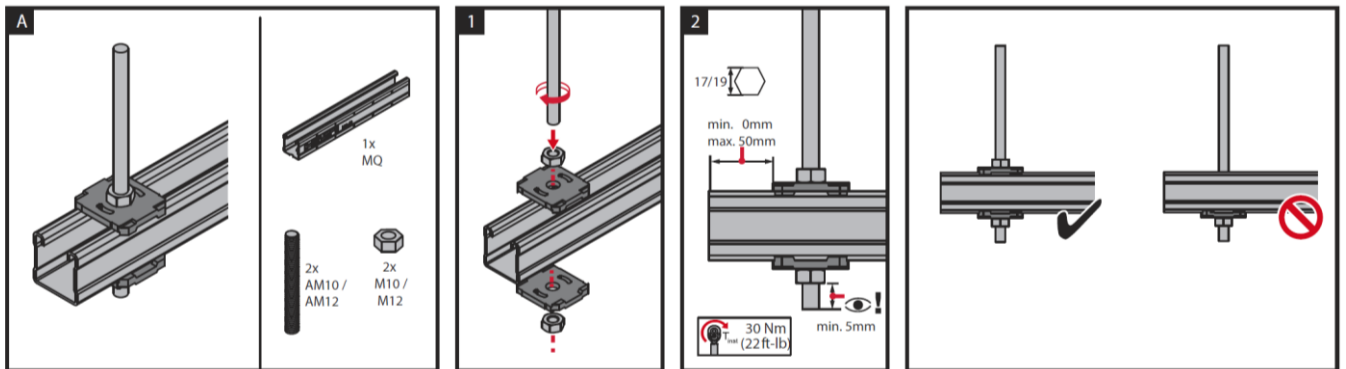

Hilti installation channel MQ-41/3, Hilti installation channel MQ-41/3 LL,  
Hilti installation channel MQ-21.5, Hilti installation channel MQ-41 and  
Hilti installation channel MQ-41-L

General assembly instructions  
Trapeze rod with Hilti MQ-41/3, MQ-41/3 LL, MQ-41, MQ-41-L and MQ-21.5

Annex E7  
(informative)

English translation prepared by DIBt

6 / 7 / 8

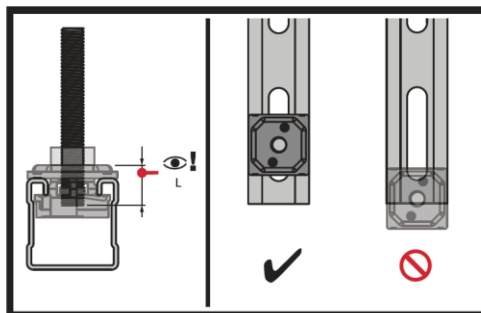
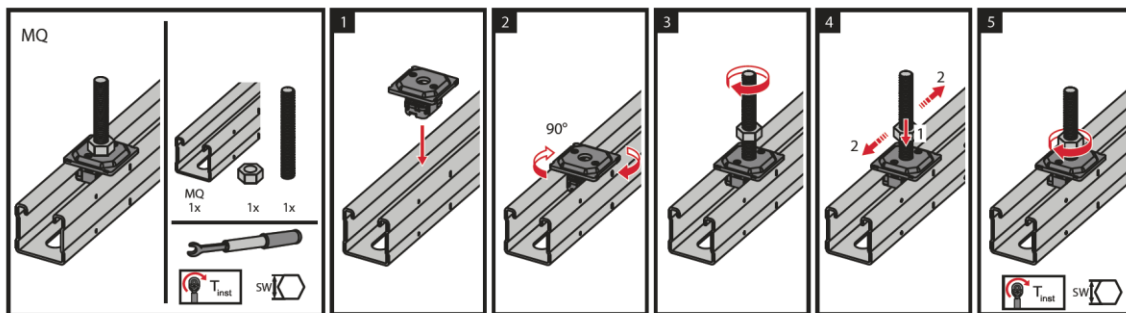

	SW	T <sub>inst</sub>	L <sub>min</sub>
M10	17 mm	18 Nm (14ft-lb)	18 mm
M12	19 mm	31 Nm (24ft-lb)	20 mm
M16	24 mm	40 Nm (30ft-lb)	23 mm

or / oder

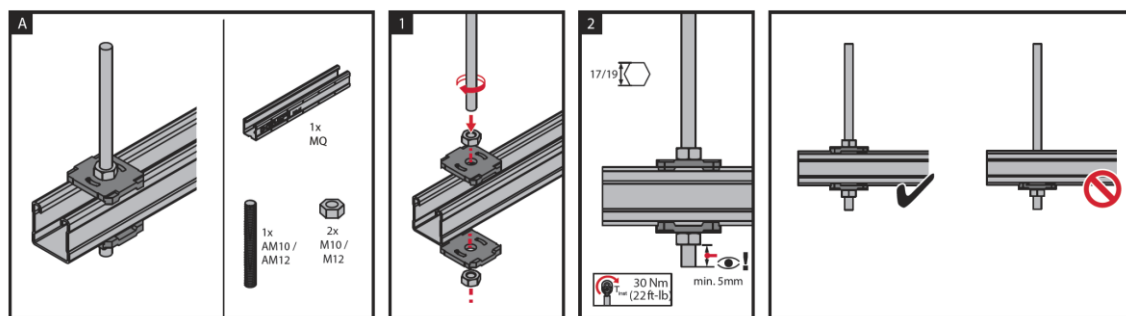

9

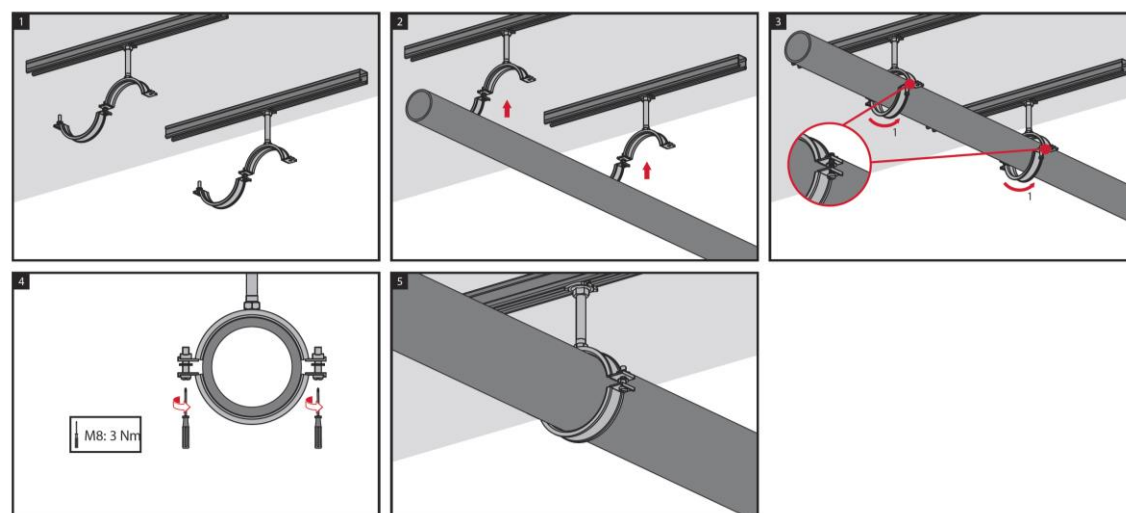

Hilti installation channel MQ-41/3, Hilti installation channel MQ-41/3 LL,  
Hilti installation channel MQ-21.5, Hilti installation channel MQ-41 and  
Hilti installation channel MQ-41-L

General assembly instructions  
Trapeze rod with Hilti MQ-41/3, MQ-41/3 LL, MQ-41, MQ-41-L and MQ-21.5

Annex E8  
(informative)

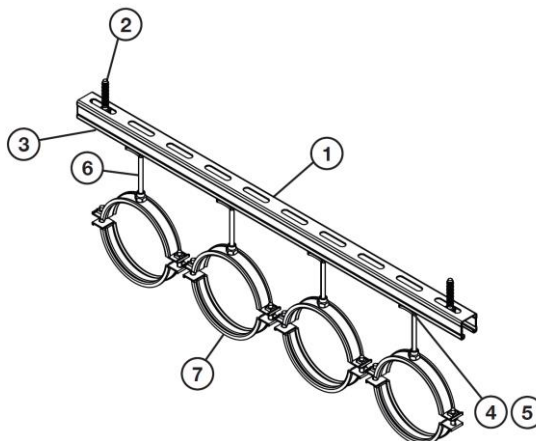

Bill of material for MQ-41/3, MQ-41/3 LL, MQ-41, MQ-41-L:

Bill of material for MQ-21.5:

Bill of material / Stückliste				
Part of typical/ Applikationselement	Ref.	Opt.	Item no. / Artikel Nr.	Description / Bezeichnung
Structure / Aufbau	Channel / Schiene	1	369596	MQ-41/3 3m channel*
		1	2048102	MQ-41/3 LL 3m channel*
		1	2141965	MQ-41-L 3m channel*
Fixation / Befestigung	2	A	2105715	HST3 M10x130 70/50 + MQZ-L11
	2	B	2079798	HUS3 -H 8x100 50/40/30 + MQZ-L11
	3	A	2199455	MQZ-L11 drilled plate
Pipe Fixation / Rohr- fixierung	M10	4	2199452	MQA-M10-B piping saddle
		5	216466	M10 hexagon nut
		6	339795	AM10x1000 4.8 threaded rod**
	M12	4	2199453	MQA-M12-B piping saddle
		5	216467	M12 hexagon nut
		6	339797	AM12x1000 4.8 threaded rod**
M16	4	2199454	MQA-M16-B piping saddle	
	5	216468	M16 hexagon nut	
	6	216422	AM16x1000 4.8 threaded rod**	
Pipe Ring / Rohrschelle	M10/ M12/M16	7	20843 - 20898	MP-MI (from 3/8" to 244.5C", with M10, 12, 16)

Bill of material / Stückliste					
Part of typical/ Applikationselement	Ref.	Opt.	Item no. / Artikel Nr.	Description / Bezeichnung	
Structure / Aufbau	Channel / Schiene	1	2184772	MQ-21.5 3m channel*	
		2	A	2079797	HST3 M10x110 50/30 + MQZ-L11
		2	B	2105714	HUS3 -H 8x85 35/25/15 + MQZ-L11
Fixation / Befestigung	3	A	2199455	MQZ-L11 drilled plate	
Pipe Fixation / Rohr- fixierung	M10	4	2199452	MQA-M10-B piping saddle	
		5	216466	M10 hexagon nut	
		6	339795	AM10x1000 4.8 threaded rod**	
	M12	4	2199453	MQA-M12-B piping saddle	
		5	216467	M12 hexagon nut	
		6	339797	AM12x1000 4.8 threaded rod**	
M16	4	2199454	MQA-M16-B piping saddle		
	5	216468	M16 hexagon nut		
	6	216422	AM16x1000 4.8 threaded rod**		
Pipe Ring / Rohrschelle	M10/ M12/M16	7	20843 - 20898	MP-MI (from 3/8" to 244.5C", with M10, 12, 16)	

\* other lengths of the channels also possible / \* andere Schienenlängen auch möglich

\*\* Threaded rod available in 1,2 & 3 meters / \*\* Gewindestange erhältlich in 1,2 & 3 Meter

MQ-21.5, MQ-41 and MQ-41-L channels can also be mounted on the base material without using MQZ-L11 drilled plates for use at ambient and elevated temperatures with the following fasteners through the roundhole: HUS3-H 8x55 5/-/(2079794), HST2 M10x90 /10 (2107847) or HST3 M10x90 30/10 (2105712).

MQ-41/3 and MQ-41/3 LL channels can also be mounted on the base material without using MQZ-L11 drilled plates for use at ambient temperatures with the following fasteners through the longhole: HUS3-H 10x60 5/-/ (2079911), HST2 M12x105/10 (2107848) or HST3 M12x105 30/10 (2105718).

Hilti installation channel MQ-41/3, Hilti installation channel MQ-41/3 LL,  
Hilti installation channel MQ-21.5, Hilti installation channel MQ-41 and  
Hilti installation channel MQ-41-L

General assembly instructions  
Headrail with Hilti MQ-41/3, MQ-41/3 LL, MQ-41, MQ-41-L and MQ-21.5

Annex E9  
(informative)

English translation prepared by DIBt

Assembly Instructions / Montagehinweise

1

Please use the Threaded rod & Anchors either in closed long holes or closed round holes in the channel  
Verwendung von Gewindestangen & Dübeln nur durch geschlossene Langlöcher bzw. Rundlöcher der Schiene

3

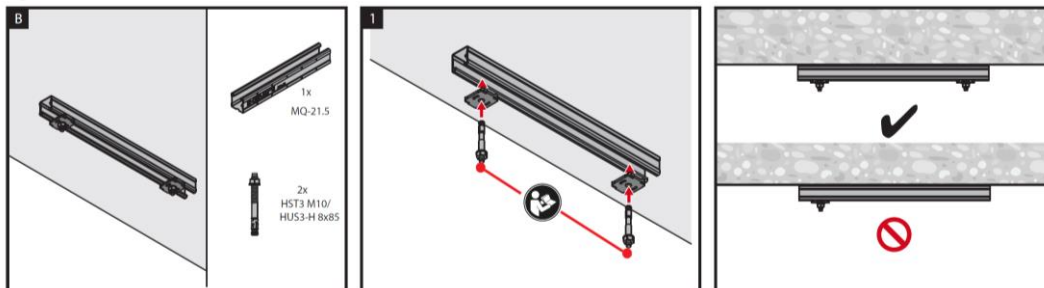

4 / 5 / 6

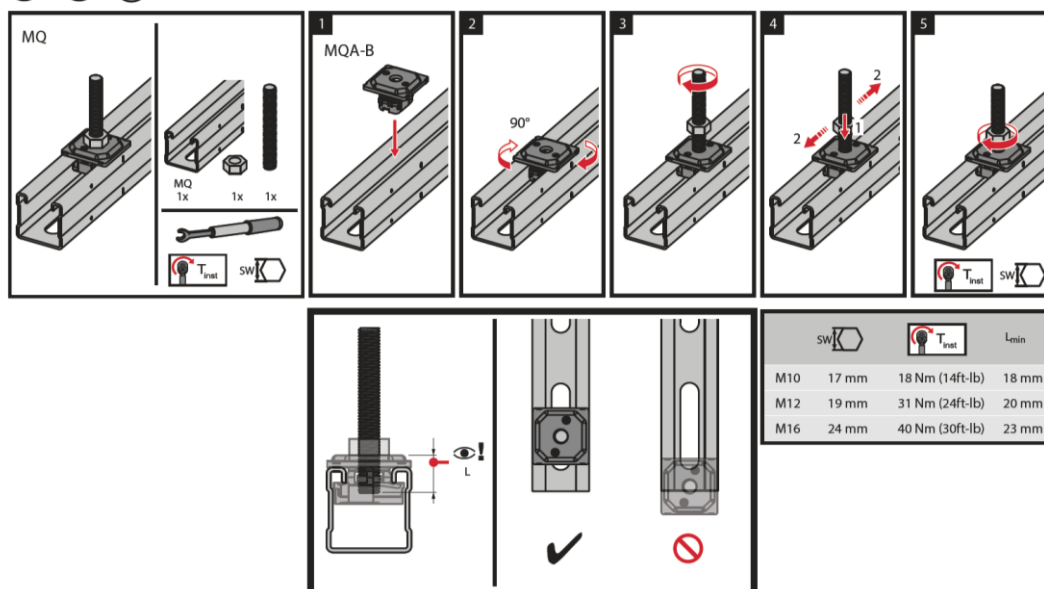

7

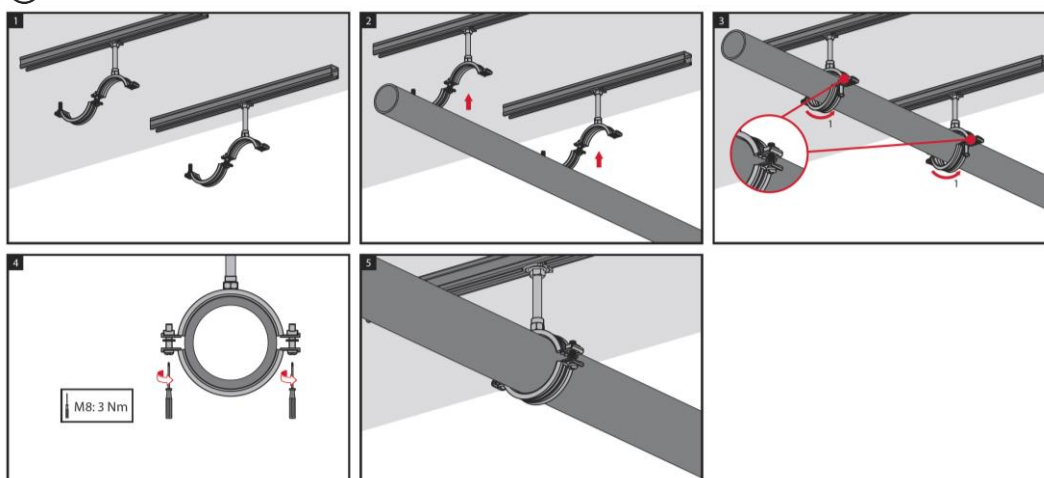

Hilti installation channel MQ-41/3, Hilti installation channel MQ-41/3 LL,  
Hilti installation channel MQ-21.5, Hilti installation channel MQ-41 and  
Hilti installation channel MQ-41-L

General assembly instructions  
Headrail with Hilti MQ-41/3, MQ-41/3 LL, MQ-41, MQ-41-L and MQ-21.5

Annex E10  
(informative)