



LAYHER EVENT SYSTEMS CATALOGUE 2021/2022



Edition 04.2021
Ref No. 8111.233

Quality management
certified according to
DIN EN ISO 9001





COMPANY FROM PAGE 4



Quality Made by Layher	4
More Speed	5
More Safety	5
More Proximity	5
More Simplicity	5
More Future	5
Decision-making aids	6
Inspection books	7

PODIUMS FROM PAGE 8

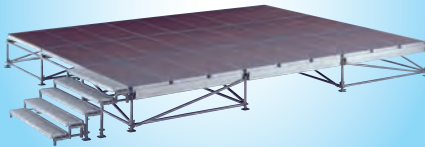

Decision-making aids	8
Allround Scaffolding	12
Basic components	14
Guardrails and stairways	16
Universal Base	18

STANDS FROM PAGE 20



Stand components	22
Stand seats	24



MIXED REALITY



In this catalogue, you can find images highlighted with the symbol for mixed reality.

By using the Layher App, you bring these scaffolding structures to life. Learn more and download the app:
app-en.layher.com

PRODUCT PORTFOLIO



The Layher Product Range – all catalogues at a glance

SpeedyScaf	Ref. No. 8102.262
Allround Scaffolding	Ref. No. 8116.258
System-free Accessories	Ref. No. 8103.260
Protective Systems	Ref. No. 8121.260
Event Systems	Ref. No. 8111.233
Access Technology	Ref. No. 8118.233

TOWERS AND WALLS FROM PAGE 26



FOH System	28
Roof and wall cladding	30
Video Wall System	32
PA Tower PLUS	34

STEEL TRUSS FROM PAGE 35

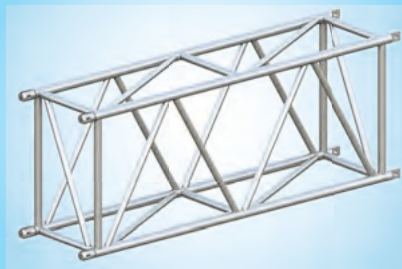

Steel Truss System	36
--------------------	----

HINWEISE

All dimensions and weights are guideline values. Component weights are subject to fluctuations due to tolerances and may therefore diverge from what is specified. Subject to technical modification.

Steel components are galvanized according to EN ISO 1461 and DASt guideline 022. Connection parts are galvanized according to EN ISO 4042.

Our deliveries shall be made exclusively in accordance with our at the conclusion of contract valid General Terms of Sale. These include the following provisions: The place of performance is Gueglingen-Eibensbach. Title to the delivered goods shall be retained until full payment has been made. The fully GTC you can find here: gtc.layher.com

Please request the specific instructions for assembly and use when ordering. Protected by copyright. Not to be reproduced, either in whole or in part. Misprints and errors excepted.

QUALITY MADE BY LAYHER



Headquarters in Eibensbach



Plant 2 in Gueglingen

QUALITY MADE IN GERMANY.

Quality made by Layher comes from Gueglingen-Eibensbach. Our company has set down deep local roots since it was established. Right up until today, development, production and management, sales and export department are all in one place, where the conditions are best for achieving quality made by Layher: in Gueglingen-Eibensbach. The two locations together cover a surface area of 318,000 m². This includes more than 148,000 m² of covered production and storage areas.

MORE POSSIBILITIES. THE SCAFFOLDING SYSTEM.

This brand promise made by Layher is the expression of a brand philosophy that we've been living by for over 75 years. More speed, more safety, more proximity, more simplicity and more future: values with which we strengthen our customers' competitiveness in the long term. With our innovative systems and solutions, we're working all the time on making scaffolding construction even simpler, even more economical and, above all, even safer.

SUSTAINABILITY AT LAYHER.

We've long been acting with a clear focus, with a view to both economic and ecological sustainability in all our process steps. Social responsibility towards employees, clients and society as a whole are at the very centre of this. We're a dependable employer, active in protecting our resources. The sparing use of work materials as a feature of our sustainable approach is fundamental to how we see ourselves: we already take care to ensure sustainable building methods when planning a new production facility, for example by greening the roofs or using photovoltaic systems. We also value locations that are close by, avoiding unnecessary CO₂ emissions due to long traffic routes. The topic of sustainability is firmly embedded in Layher's organisational structure thanks to its energy management team. Their work has paid off in particular in the form of DIN EN ISO 50001 certification.



Discover the world of Layher
in its company film at:
yt-image-en.layher.com





MORE SPEED

High level of material availability, effective delivery service and quick assembly and dismantling of the scaffolding systems thanks to 100% fitting accuracy.



MORE SAFETY

Outstanding quality and precision coupled with a long service life – confirmed internationally through independent certifications, inspections and approvals. Continuity and long-term partnership.

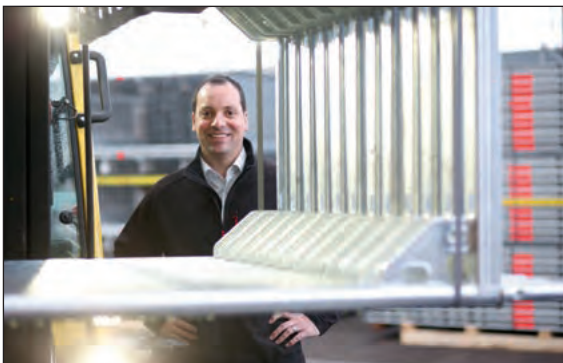

MORE PROXIMITY

Comprehensive personal consultation and close-knit delivery network. Global presence through our own subsidiaries. Family-owned company that works closely with its customers.



MORE SIMPLICITY

Economical scaffolding systems that have been proven in practice, available with an extensive product range. Cross-system combinations for versatile use. Rapid decision making thanks to efficient structures and processes.



MORE FUTURE

Thanks to permanent product innovations and the improvement of existing parts. By opening up new areas of business. With an integrated system to ensure high profitability and retention of investment value. Through an extensive range of training opportunities and seminars to ensure that customers are always right up-to-date with the latest technical and commercial developments.

Layher Lightweight: Through the use of high-tensile steel, a new production process, and an improved design, we have succeeded in minimising the weight of the core components of our systems – while maintaining or raising load-bearing capacity.



Layher LayPLAN

Time and material are crucial factors in scaffolding construction. To make the most efficient use of both, the Layher range includes the practical LayPLAN scaffolding planning software.

LayPLAN CAD

For more complex structures, LayPLAN CAD is available. This is a plug-in for Autodesk AutoCAD. It enables 3-dimensional planning of scaffolding structures of all types.

A visual collision check is possible with the aid of volume rendering. By using a convenient search function with preview image, scaffolding planners will find not only an extensive library of individual Layher parts, but also assemblies already prefabricated for even faster design work. The detailed drawings can then be printed out. A transfer to visualisation or animation software is also possible without any problem. This allows projects not only to be planned economically and at the same time adapted precisely to actual requirements, but also to be presented professionally to customers.

After finalisation of the scaffolding proposal, the LayPLAN Material Manager provides you with complete lists of required parts to ensure you always have precisely the material you need at the site.

How can I buy LayPLAN?

Registration and all the ordering processes can be conveniently accessed at the Layher website: <http://software.layher.com>

A contact form gives you the data to access our software portal, where you can download a 30-day test version and also find the order form for the full version.

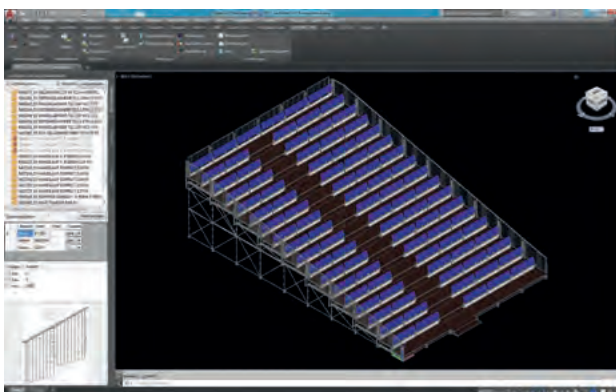
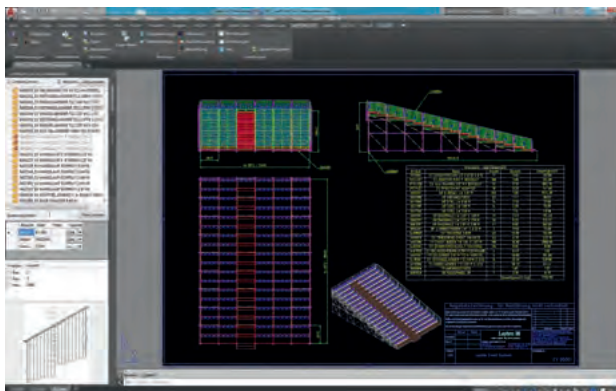

Planning of a grandstand in LayPLAN CAD

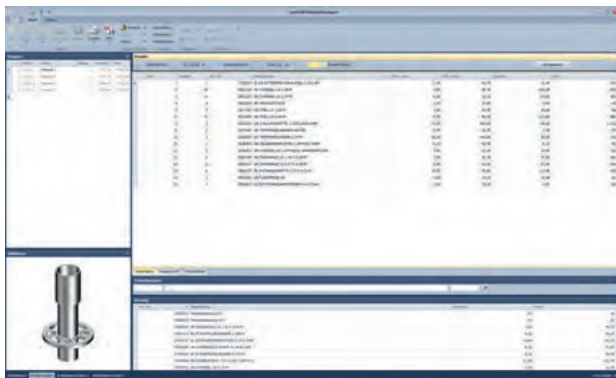

Component images LayPLAN Material Manager
Part of LayPLAN CLASSIC and LayPLAN CAD

Pos.	Description	Ref. No.
1	LayPLAN CAD plug-in for AutoCAD, for designing complex scaffolding in 3D	6345.103

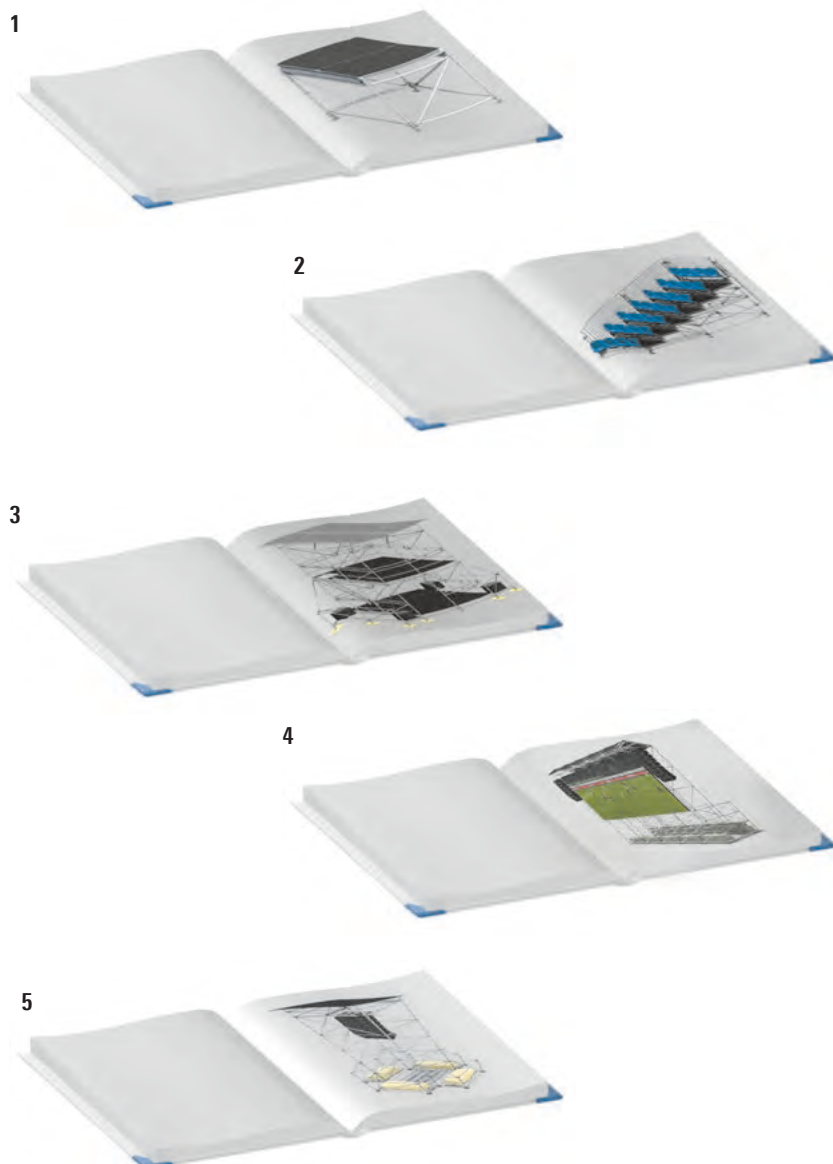

Events held outdoors frequently require the building of structures (structural systems) such as stages, stands, FOH Towers, video wall systems or PA Towers.

If these structural systems are both suitable and intended for repeated assembly and dismantling at different locations, they are deemed to be Temporary Structures.

Temporary Structures require Model Approval before they are erected and put into service for the first time.

Model Approval is granted for a defined period that should not exceed five years. It can be extended a further five years on written request. Model Approval and its extension is entered in an Inspection Book.

The Inspection Book contains:

- ▶ Detailed plans of the entire structure
- ▶ Detailed part drawings
- ▶ Appropriate excerpts from approvals, where these are referred to in the structural strength analysis
- ▶ Complete and verifiable structural strength analysis according to valid laws, provisions and standards
- ▶ Certificates
- ▶ Test Report

Our customers can obtain from Layher inspection books for modular and standardised structures. Accordingly, the assembly variants can be clearly defined, and the typical variants can be verified in structural strength calculations.

Pos.	Description	Type	Ref. No.
Inspection book with Model Approval			
1	Inspection book for Event Podium	EV86	5400.002
		EV100	5400.004
		EV104	5400.005
2	Inspection book for Event Stand	EV86	5400.007
		EV86Q	5400.003
		EV100	5400.101
		EV104	5400.006
3	Inspection book for FOH Tower	EV100 / EV104	5400.150
4	Inspection book for FOH Tower	EV100 / EV104	5400.160
5	Inspection book for PA Tower PLUS	EV100 / EV105	5400.170
Static Calculations – not for German market			
6	Static calculation for FOH Tower	EV100 / EV104	5400.155
7	Static calculation for video wall system	EV100 / EV104	5400.165
8	Static calculation for PA Tower PLUS	EV100 / EV104	5400.175
9	Static calculation for side stages	EV100 / EV104	free download

= delivery time on request

LAYHER PODIUMS AND STAND SYSTEMS

DECISION-MAKING AIDS

LAYHER PODIUMS

Layher podiums are just as suitable for use inside halls and marquees as use outdoors. The components make up a construction kit allowing the building of a small podium for fashion shows, for a music performance or for a giant concert stage. The parts are weatherproof, thanks to the use of aluminium, hot-dip galvanized steel and coated plywood panels. On uneven surfaces, fast and easy adaptability of the Allround podiums to the lie of the land is a particular

advantage. The permissible loading capacity of the podium surface is up to 7.5 kN/m². The height can, depending on the structural strength, be up to 10 m. Meeting of the guidelines for temporary structures with the design loads as per DIN 4112 is verified by inspection books issued by the competent authority.

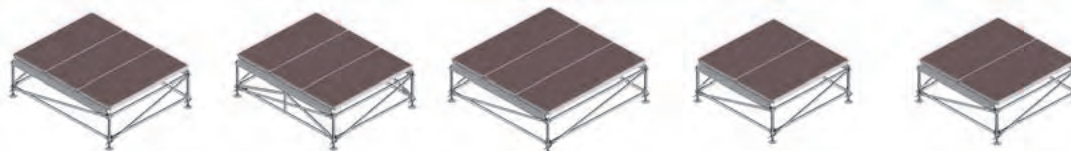

Module	EV 86	EV 86+	EV 86Q	EV 100 Metric*	EV 104
Bay	2.07 x 2.57 m	2.07 x 2.57 m	2.57 x 2.57 m	2.00 x 2.00 m	2.07 x 2.07 m
Deck type	Event deck	Event deck	Event deck	Event deck	Event deck
Deck size	0.86 x 2.07 m	0.86 x 2.07 m	0.86 x 2.57 m	1.00 x 2.00 m	1.04 x 2.07 m
Decks per bay	3	3	3	2	2
Support element	Event transom	Event transom	Event transom	Event transom	Event transom
Support element length	2.57 m	2.57 m	2.57 m	2.00 m	2.07 m
Crosspiece support	–	required	–	–	–
Perm. load capacity	5.0 kN/m ²	7.5 kN/m ²	5.0 kN/m ²	7.5 kN/m ²	7.5 kN/m ²



* Further metric components, see catalogue Allround Scaffolding.



LAYHER STANDS

The most important characteristics of Layher seating stands are: sturdy material, sound workmanship, long service life, rapid assembly at changing locations, and low transport volume. The individual parts are easy to assemble and lightweight, so that they can be installed manually. Please refer to our

tables in this connection. Thanks to the modular design, it is possible to adapt the stand to the local conditions and to plan it in accordance with local regulations.



EV 86 x 16



EV 86 x 25



EV 86 x 33



EV 100 x 25, Metric*
EV 104 x 25

Seating stand	EV 86 x 16	EV 86 x 25	EV 86 x 33	EV 100 x 25 Metric*	EV 104 x 25
Step width	0.857 m	0.857 m	0.857 m	1.00 m	1.036 m
Step height	0.166 m	0.25 m	0.333 m	0.25 m	0.25 m
Riser angle [Degree]	11°	16.3°	21.1°	14°	13.6°
Riser angle [%]	19.4 %	29.2 %	38.6 %	24.9 %	24.2 %
Standard dimension	2.57 x 2.07 m	2.57 x 2.07 m	2.57 x 2.07 m	2.00 x 2.00 m	2.07 x 2.07 m
Loose seating	possible	possible	possible	recommended	recommended
Permanently fitted benches	recommended	recommended	recommended	possible	possible

More variants upon request

LAYHER EVENT STAGES AND POSIUMS

LAYHER STAGES AND POSIUMS – EASIER, QUICKER AND SAFER BY USING THE MODULAR LAYHER SYSTEM



No compromising on site, fulfils requirements in terms of dimension and equipment: Layher Event Stages and Podiums.

Layher podiums and stages provide a safe play performance area that's exactly what's needed. Series manufacture and high delivery readiness are our way to help you cut costs and achieve economic success; and tailor-made special solutions whenever necessary are our strengths.

THE BENEFITS FOR YOU:

- ▶ **Basic unit**
Can be expanded with a choice of layouts, standard dimensions and performing levels.
- ▶ **Expandable**
Caters for requirements with a variety of roof and support systems.
- ▶ **Allround base**
High load-bearing capacity, rapid assembly and dismantling.
- ▶ **Practically-minded design**
Strong connector technology, ergonomic handling, low-wear aluminium parts, corrosion-proof thanks to hot-dip galvanisation, space-saving storage.

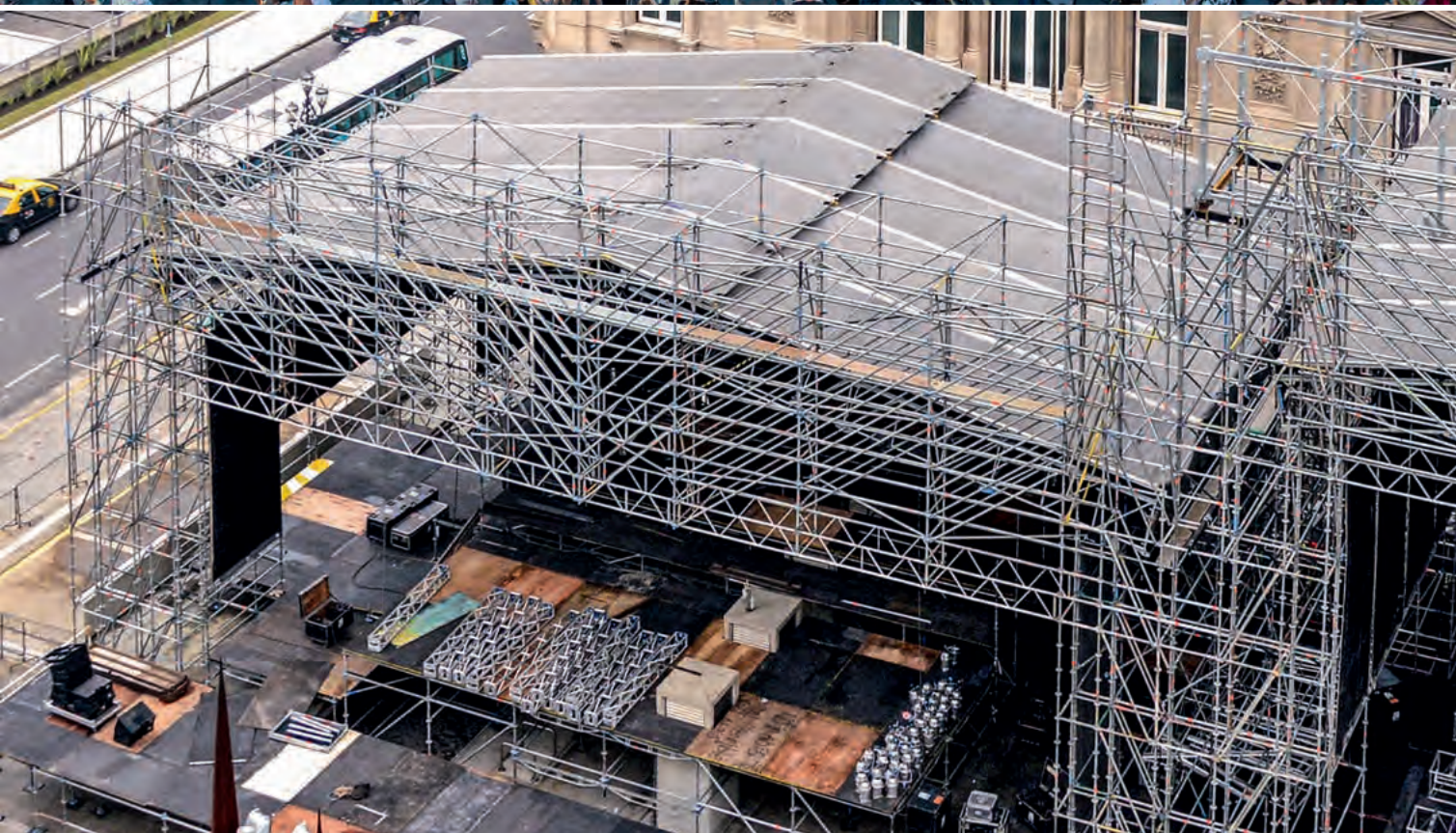

Allround Scaffolding

Parts from the Layher Allround Scaffolding construction kit are used as the substructure for podiums.

The **diagonal braces 1** with rotatable wedge heads further brace the basic system consisting of standards and ledgers, providing convincingly high connection values.

The **O-ledgers horizontal-diagonal 2** can be used as an assembly aid to ensure rectangularity in the ground plan. Many structures exploit the bracing effect of the horizontal-diagonal braces.

The O-ledgers horizontal-diagonal have:

- ▶ straight-welded wedge heads for a square ground plan
- ▶ obliquely welded wedge heads for a rectangular ground plan

The **O-ledgers 3** with welded wedge heads connect the standards to one another.

The **standards 7** are made from hot-dip-galvanized steel tube dia 48.3 mm. The rosettes spaced 0.50 m apart permit the connection of **ledgers 3** and **diagonal braces 1**.

To connect the individual standards, **spigots 4** are used. The latter are fastened in the lower standard using **special bolts M12 x 60 with nut 6**. The upper standard is pinned using **hinged pins 5**. Alternatively, also using **special bolts 6**.

The **standard 0.67 m 8a** and the **standard 1.17 m 8b** can be used alternatively for stages with heights of 0.90 m and 1.40 m respectively, enabling the base collar to be omitted. Assembly proceeds faster, and ballast can be placed at the bottom scaffolding level. The standard 1.17 m can be extended using **spigots 4**.

The **standard lock 0.50 m 9** can create a pull-resistant connection between the base collar and the standard. It is needed if the ballast has to be placed at the lowest scaffolding level.



The lowest possible podium height is about 0.35 m, for which **base plates 20 11a** and **base collars short 10a** are used. For greater heights, **base plates 60 solid 11b**, **base collars 10b** and **standards without spigots 7**, in the appropriate length are used.

The **rubber pad 12** minimises slippage of the structure and helps to protect sensitive indoor floors. Inserted between the load-distributing support and the base plate, it can help in many cases to reduce the amount of ballast.



Further components and more detailed information can be found in the Allround Scaffolding price list.

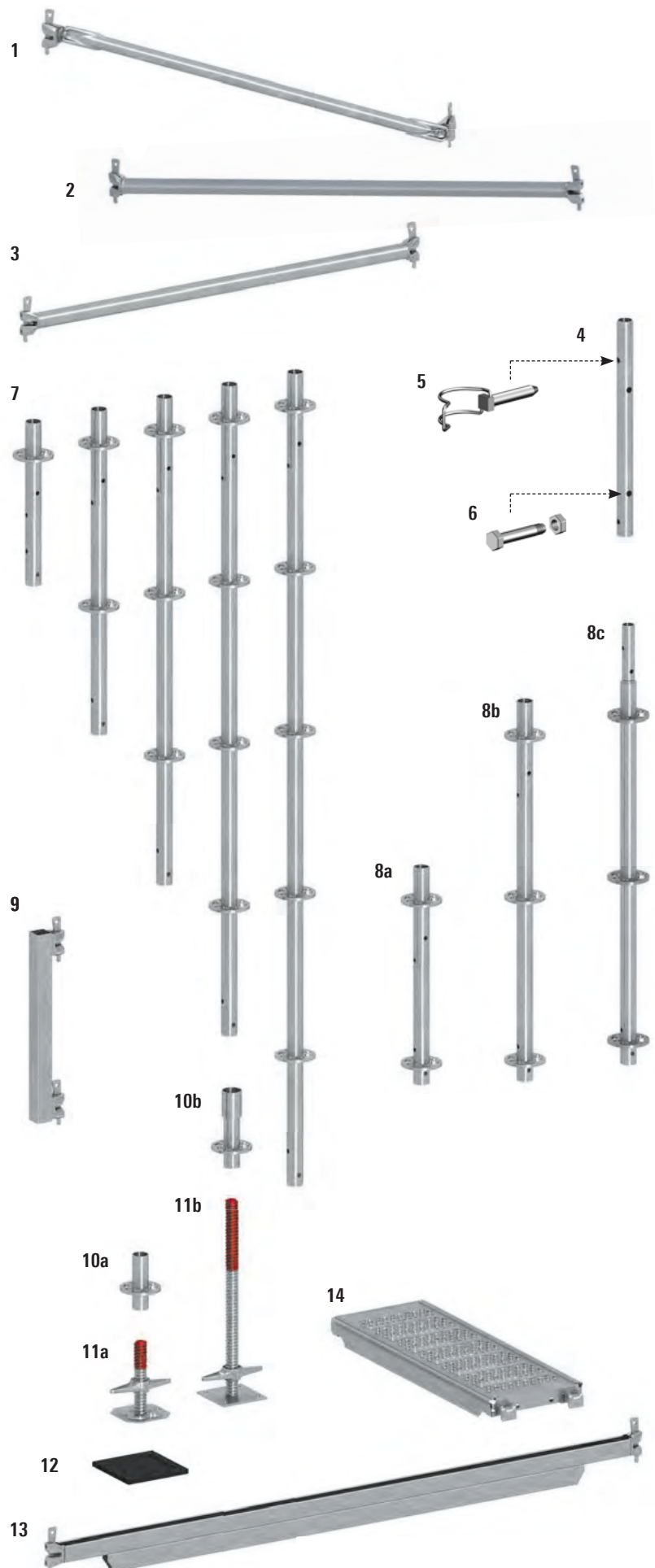

Pos.	Description	Dimensions L/H x W [m]	Weight approx. [kg]	PU [pcs.]	Ref. No.						
1	Diagonal brace LW , steel										
						2.00 m bay height	1.00 m Bay length	2.22	7.3	50	2683.100
							1.04 m Bay length	2.23	7.6	50	2683.104
							2.00 m Bay length	2.76	8.8	50	2683.200
							2.07 m Bay length	2.81	8.9	50	2683.207
							2.57 m Bay length	3.18	10.0	50	2683.257
						1.50 m bay height	1.00 m Bay length	1.77	6.2	50	2682.100
							1.04 m Bay length	1.79	6.2	50	2682.104
							2.00 m Bay length	2.42	8.0	50	2682.200
							2.07 m Bay length	2.48	8.2	50	2682.207
							2.57 m Bay length	2.89	9.5	50	2682.257
						1.00 m bay height	1.00 m Bay length	1.36	5.0	50	2681.100
							1.04 m Bay length	1.39	5.1	50	2681.104
							2.00 m Bay length	2.14	7.2	50	2681.200
							2.07 m Bay length	2.20	7.4	50	2681.207
							2.57 m Bay length	2.66	8.6	50	2681.257
						0.50 m bay height	1.00 m Bay length	1.03	4.0	50	2680.100
							1.04 m Bay length	1.08	4.2	50	2680.104
							2.00 m Bay length	1.96	6.7	50	2680.200
							2.07 m Bay length	2.03	6.9	50	2680.207
2.57 m Bay length	2.51	8.2	50	2680.257							
2	O-ledger LW , horizontal-diagonal, steel for 2.00 m bay length, 1.00 m bay width	left	2.23	7.8	50	2678.201					
			2.83	9.6	50	2678.200					
		left	2.32	8.1	50	2678.206					
			2.93	10.0	50	2678.207					
		right	3.30	11.2	50	2678.255					
			3.64	12.2	50	2678.257					
3	O-ledger LW , steel with AutoLock function		0.86	3.3	50	2601.086					
			1.00	3.7	50	2601.100					
			1.04	3.8	50	2601.103					
		The ledgers 0.86 m and 1.72 m are used for podiums or stands and correspond to 1/3 resp. 2/3 of a 2.57 m bay.	1.72	5.9	50	2601.172					
		The ledger 1.04 m corresponds to a half 2.07 m bay.	2.00	6.8	50	2601.200					
		The ledger 1.29 m corresponds to a half 2.57 m bay.	2.07	7.0	50	2601.207					
			2.57	8.5	50	2601.257					
4	Spigot , steel for standards Ref. No. 2619.xxx and 2604.xxx	0.52	1.6	350	2605.000						
5	Hinged pin , dia. 12 mm with pan-head		2.0	20	4905.668						
6	Special bolt M12 x 60 , with nut		4.0	50	4905.062						
7	Standard LW , steel without spigot for scaffolding layer	0.50	2.5	300	2619.050						
		1.00	4.6	28	2619.100						
		1.50	6.6	28	2619.150						
		2.00	8.8	28	2619.200						
		2.50	11.7	28	2619.250						
		3.00	13.7	28	2619.300						
8a	Standard LW , 0.67 m, with 2 rosettes, without spigot with integrated base collar	0.67	3.3	200	2619.066						
8b	Standard LW , 1.16 m, with 3 rosettes, without spigot with integrated base collar	1.16	5.5	28	2619.116						
8c	Standard LW , 1.16 m, with 3 rosettes, with spigot with integrated base collar	1.16	5.7	28	2617.116						
9	Standard lock , 0.50 m	0.58	4.0	100	2603.000						
10a	Base collar , short	0.17	1.1	250	5601.000						
10b	Base collar	0.24	1.4	500	2602.000						
11a	Base plate 20 max. spindle travel 10 cm	0.20	2.3	200	5602.020						
11b	Base plate 60 , solid, max. spindle travel 41 cm	0.58	6.7	200	5602.060						
12	Rubber pad for base plate for slip-reduction on solid grounds like concrete, asphalt, stone or timber, protects sensitive deckings from damages	0.20 x 0.20	0.4	10	4000.500						
13	U-ledger reinforced LW T14 , Steel	2.00	12.5	50	2618.200						
		2.07	12.7	50	2618.207						
14	U-steel deck LW, 0.32 m wide steel, hot-dip galvanized perforated, non-slip working surface	1.00 x 0.32	7.2	60	3883.100						
		1.04 x 0.32	7.4	60	3883.104						
		2.07 x 0.32	13.4	60	3883.207						
		2.00 x 0.32	14.9	60	3802.200						

WS = wrench size PU = packaging unit = available ex works = delivery time on request = only available in this packaging unit

Podiums – Basic components

The plywood board of the **Event decks 1** is riveted onto an aluminium frame and is also supported by cross rungs. All four sides of the Event decks can be fitted into the Event crosspiece. The removable plastic corners allow the vertical tubes to be passed through.

The **X-Event decks 2** have plywood boards with rectangular corners. The detachable plastic corners are not removable. Guardrails can be mounted by using posts Ref. No. 5406.000 to the podium.

The Event decks with lengths of up to 2.07 m are rated for a load of 7.5 kN/m². The Event deck 2.57 m can withstand 5 kN/m².

The 18 cm high **Event transom 3** made of aluminium section with wedge head connection of galvanized steel is used as a support for the Event decks.

The loading capacity of the 2.57 m long Event crosspiece can be increased from 5 kN/m² to 7.5 kN/m² by fitting the **transom support 4**.

The **Tension clasp 5** of spring steel connects the Event deck to the Event transom and acts as a lock against lift-off.

A gap-free podium surface is assured by a shift preventer at the edge of the podium assembled using **square half coupler 6**.

Optionally, the Event decks can be connected to one another using the **clamp 7** made of plastic.

The Event decks are supplied with plastic corners fitted. The matching **plastic corners 8** are available in packaging units of 50 as spare parts.

The design variant of the existing Event decks should be taken into account when ordering toggle latches, clamps and plastic corners.

- ▶ Year built after 2016: Event deck T16
- ▶ Year built 2007–2016: Event deck T10 and T7
- ▶ Year built 2004–2007: Event deck T4
- ▶ Year built 2001–2004: Event deck T1

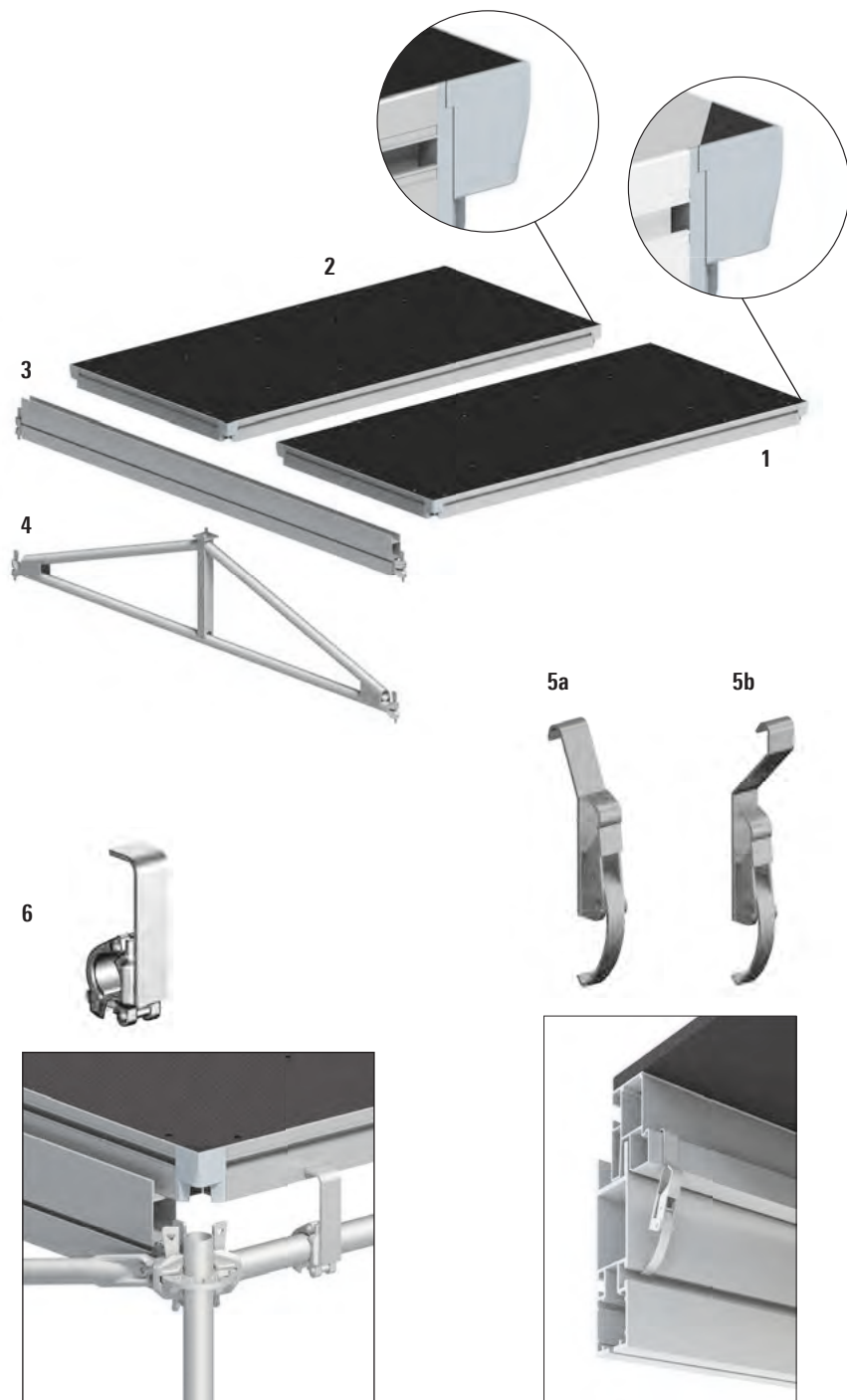

For the basic variants of the podiums, an inspection book can be ordered. See page 7.

7a



7b



8a



8b



Pos.	Description	Dimensions L/H x W [m]	Weight approx. [kg]	PU [pcs.]	Ref. No.	Usable			
						EV/86	EV/86Q	EV/100	EV/104
1	Event deck T16 aluminium frame, coated plywood, detachable plastic corners	0.86 x 1.04	16.9	10	5402.201	🕒	▶		
		0.86 x 2.07	30.2	10	5402.202	🏗️	▶		
		0.86 x 2.57	36.7	10	5402.204	🏗️		▶	
		1.00 x 1.00	18.3	10	5402.205	🕒			▶
		1.00 x 2.00	32.5	10	5402.206	🏗️			▶
		1.04 x 1.04	19.3	10	5402.208	🕒			▶
		1.04 x 2.07	34.3	10	5402.209	🏗️			▶
2	X-Event deck T16 as Pos. 1, but with not detachable plastic corners	0.86 x 1.04	16.9	10	5402.211	🕒	▶		
		0.86 x 2.07	30.2	10	5402.212	🕒	▶		
		0.86 x 2.57	36.7	10	5402.214	🕒		▶	
		1.00 x 1.00	18.3	10	5402.215	🕒			▶
		1.00 x 2.00	32.5	10	5402.216	🕒			▶
		1.04 x 1.04	19.3	10	5402.218	🕒			▶
		1.04 x 2.07	34.3	10	5402.219	🕒			▶
3	Event transom	0.86	6.1	60	5400.072	🏗️	▶		
		1.00	6.4	60	5400.010	🏗️			▶
		1.04	6.6	60	5400.020	🏗️			▶
		1.71	10.0	60	5400.071	🏗️	▶		
		2.00	11.4	60	5400.040	🏗️			▶
		2.07	12.0	60	5400.050	🏗️			▶
		2.57	14.6	60	5400.070	🏗️	▶	▶	
4	Transom support increases permissible load on the EV 86+ system	2.57 x 0.50	21.2	40	5400.100	🏗️	▶		
5a	Tension clasp T16, for Event deck T16	0.16	2.5	50	5403.521	🏗️	▶	▶	▶
5b	Tension clasp, for Event deck T10, T7, T4 und T1	0.16	2.6	50	5403.515	🏗️	▶	▶	▶
6	Square half-coupler		1.4	25	5403.510	🏗️	▶	▶	▶
7a	Clamp yellow, for Event decks T16		0.3	50	5403.518	🏗️	▶	▶	▶
7b	Clamp black, for Event decks T10, T7		0.4	40	5403.506	🏗️	▶	▶	▶
8a	Plastic corner, 2-coloured, grey-brown spare part for Event deck T16		3.5	50	5403.523	🏗️	▶	▶	▶
8b	Plastic corner, brown spare part for Event deck T10, T7, T4		3.4	50	6494.103	🏗️	▶	▶	▶

WS = wrench size PU = packaging unit 🏗️ = available ex works 🕒 = delivery time on request 🏗️ = only available in this packaging unit

Podiums – Guardrails and stairways

Side protection of the stage is provided by **handrails 2** or **guardrails with child safety features 3**. The handrail has a height of 1 m above the deck, and the guardrails are 1.10 m high. To absorb the horizontal forces as specified for areas used by the public, **guardrail posts 1** are used.

Alternatively, standards going all the way through can be installed in conjunction with additional parts for strengthening.

Variant A:

Round tube with four welded top pieces (Ref. No. 5405.075), see page 22.

Variant B:

Standard 2m (Ref. No. 2619.200) fastened with four twin wedge head couplers, (Ref. No. 2629.000).

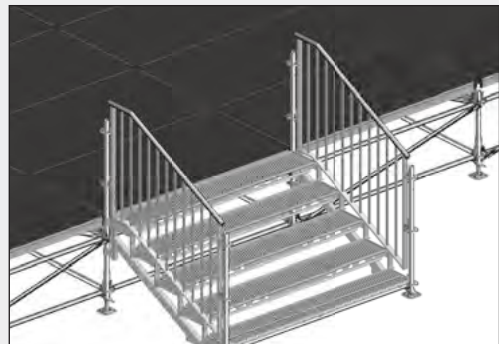

The 5-step **U-stairway stringer 5** forms a stair for a podium height of 0.85 m. The top step is flush with the podium surface.

- ▶ Riser $s = 16$ cm
- ▶ Tread $a = 31.8$ cm
- ▶ Undercut $u = 0.2$ cm

Depending on the podium height, the stair can be extended using different stair stringers.

N.B.: When different stair stringers are combined, the tread dimensions are not uniform.

Four steel decks 0.32 m and one steel deck 0.19 m are needed as steps. A ledger with gap cover (Ref. No. 2675.xxx) is also installed as the lower step edge.

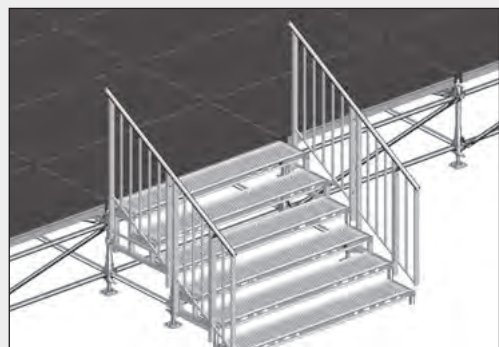

The artist entry to the stage is via the modular stairway. The construction kit comprises: **stringer for modular stairway, 1, 2 and 3 steps 6, base collar 0.26 m 8 and O-ledge 0.90 m 10.**

The bolts for guardrail assembly are included with every **stair guardrail 7**. The steps installed are five robust decks 0.32 m or five steel decks 0.32 m in the selected length. The steps are fastened using **lift-off preventers 11**.

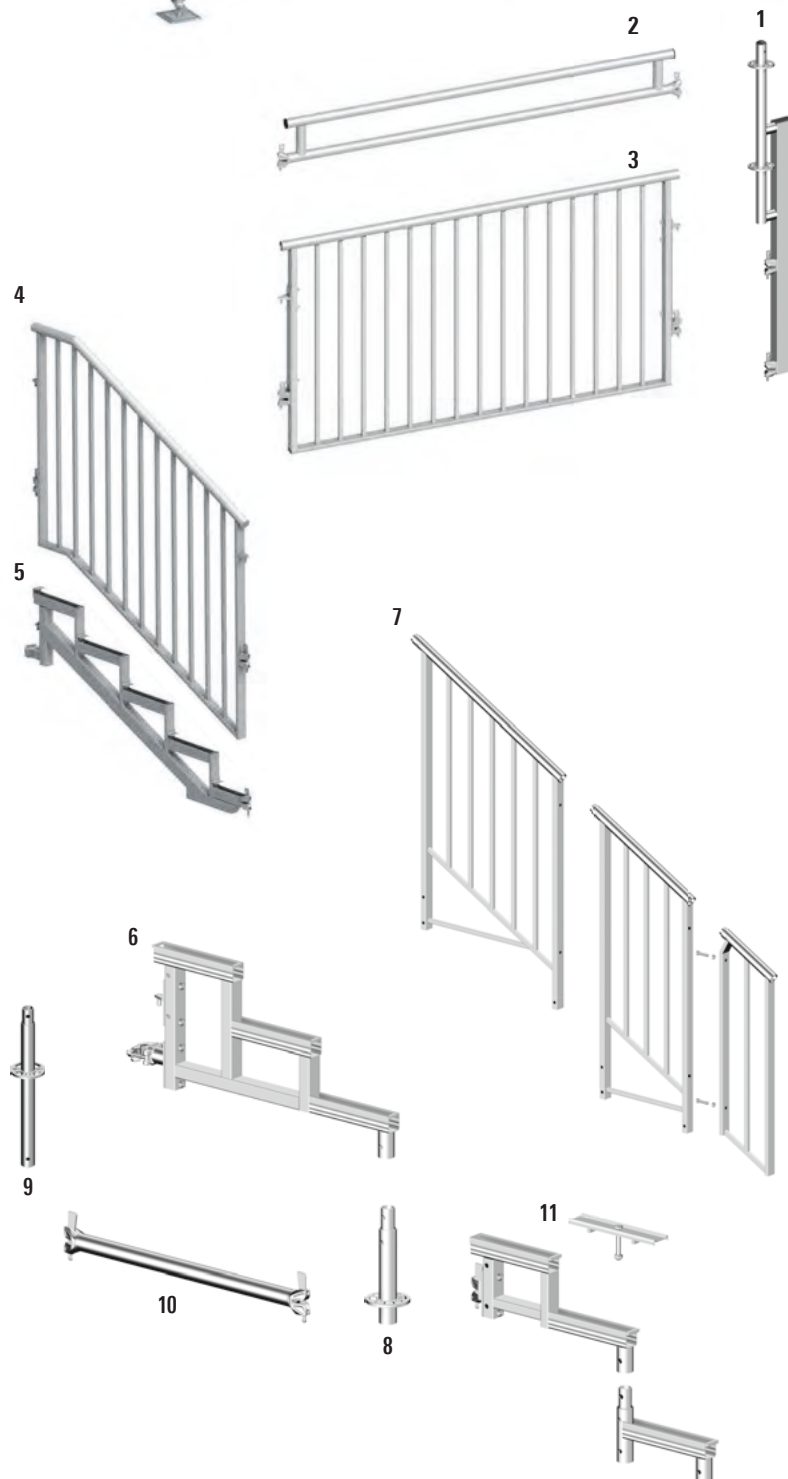
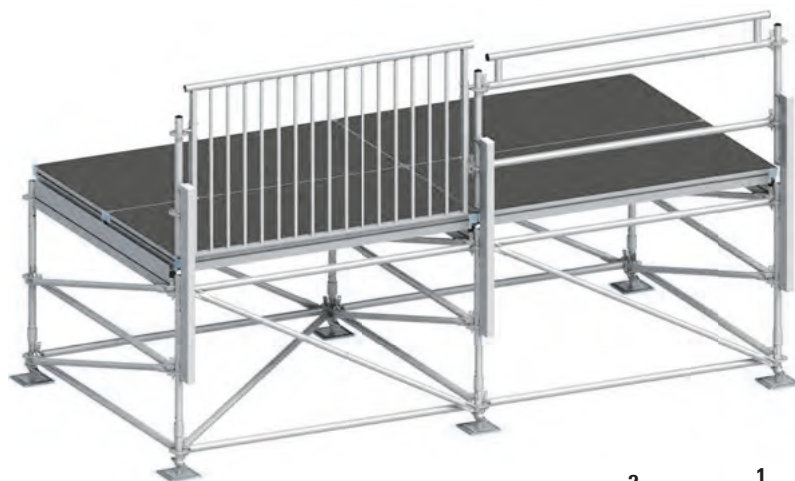

For further information,
please see catalogue
Allround Scaffolding.



Pos.	Description	Dimensions L/H x W [m]	Weight approx. [kg]	PU [pcs.]	Ref. No.	Usable						
						EV 86	EV 860	EV 100	EV 104			
1	Guardrail post for podium	1.64	13.8	20	5406.000		▶	▶	▶	▶		
2	Handrail T13 handrail height 1.00 m	1.00	7.9	20	5417.100				▶			
		1.04	8.1	40	5417.104					▶		
		2.00	14.0	40	5417.200					▶		
		2.07	14.5	40	5417.207		▶				▶	
		2.57	18.7	40	5417.257		▶	▶				
3	Guardrail with child safety feature T12 guardrail height 1.10 m, connection elements height adjustable for use with Event or scaffolding decks	0.86	18.5	25	5409.086		▶	▶				
		1.00	19.8	25	5409.100					▶		
		1.04	20.0	25	5409.104						▶	
		1.57	25.8	25	5409.157		▶	▶				
		2.00	30.5	25	5409.200						▶	
		2.07	30.8	25	5409.207		▶					▶
		2.57	35.8	25	5409.257		▶	▶				
4	Stairway guardrail 750 with child safety feature for stairway stringer Pos. 5	1.57 x 1.10	22.0	25	2616.106		▶	▶	▶	▶		
5	U-Stairway stringer 750 with half-coupler with 5 steps	1.57 x 1.00	18.5	20	2639.003		▶	▶	▶	▶		
6	Stringer for modular stairway	1-step	0.30	2.4	50	5407.001		▶	▶	▶	▶	
		2-step	0.60	5.5	50	5407.002		▶	▶	▶	▶	
		3-step	0.90	8.0	20	5407.003		▶	▶	▶	▶	
7	Guardrail for modular stairway	1-step	0.30 x 1.10	6.5	40	5407.011		▶	▶	▶	▶	
		2-step	0.60 x 1.10	14.0	25	5407.012		▶	▶	▶	▶	
		3-step	0.90 x 1.10	16.0	25	5407.013		▶	▶	▶	▶	
8	Base collar for modular stairway, 0.26 m with spigot	0.26	2.0	450	5407.021		▶	▶	▶	▶		
9	Standard for modular stairway, 0.59 m with spigot	0.59	3.1	250	5407.022		▶	▶	▶	▶		
10	O-ledger LW, 0.90 m	0.90	3.4	50	2601.090		▶	▶	▶	▶		
11	Lift-off preventer, 0.29 m, with bolt	0.29	0.4	500	5407.030		▶	▶	▶	▶		

Universal Base

The Universal Base connects your roof structure efficiently to a Layher podium. The position of the roof supports can be set infinitely inside the Universal Base.

The advantages are:

- ▶ The dead weight of the podium can be taken account of in the structural calculation, meaning that less ballast is needed.
- ▶ Forces arising from the rope hoist (wind braces) are absorbed by the podium, meaning that less ballast is needed.
- ▶ Greater headroom at the level of the wind braces due to attachment points being provided at the deck level.
- ▶ Rapid assembly of the podium thanks to the assembly advantages of Layher Allround Scaffolding.

The use of serrated rails in conjunction with serrated bolts permits defined transmission of the horizontal forces. The **base plate 4/5** always rests on two **truss-transoms 3**. The orientation of the transoms has effects to the position of the Event transoms and the outer position of the roof support.

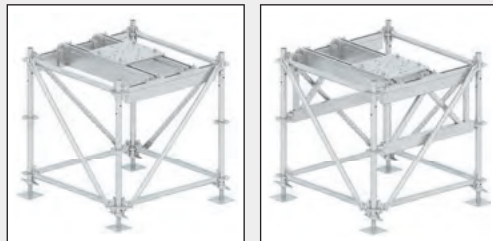
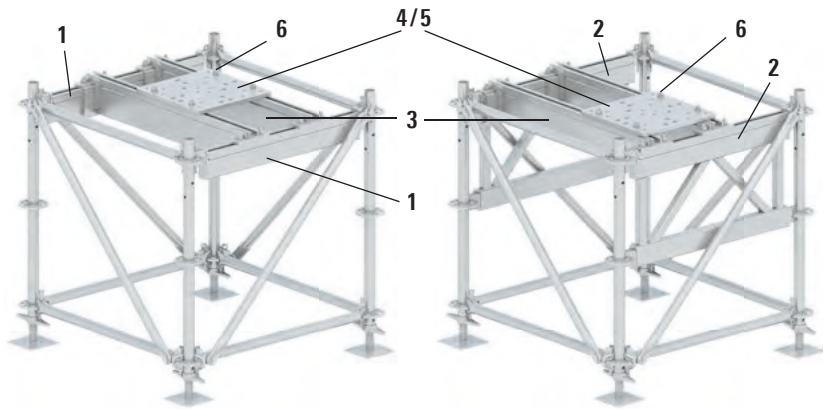

Example A:

Base plate 4 in the middle of the bay, even distribution of the load onto four rosettes, thanks to use of the **base beam 1**.

Example B:

Base plate 4 in the corner, distribution of the load onto eight rosettes, thanks to use of the **base beam 2**.

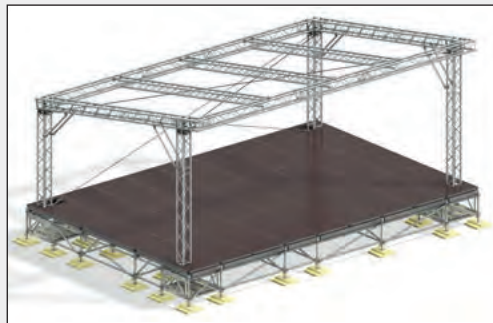

Typical use:

Universal bases in the podium corners are used to receive the roof supports.

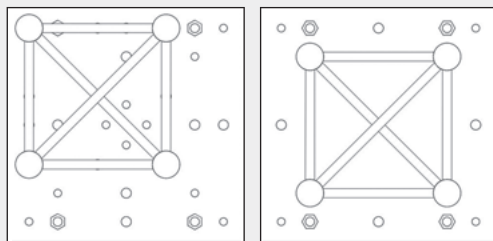

Base plate type 1

The plate type 1 with additional drillings allows the asymmetrical positioning of the towers. Additionally there are drillings in the platte centre for an optional support.

Base plate type 2

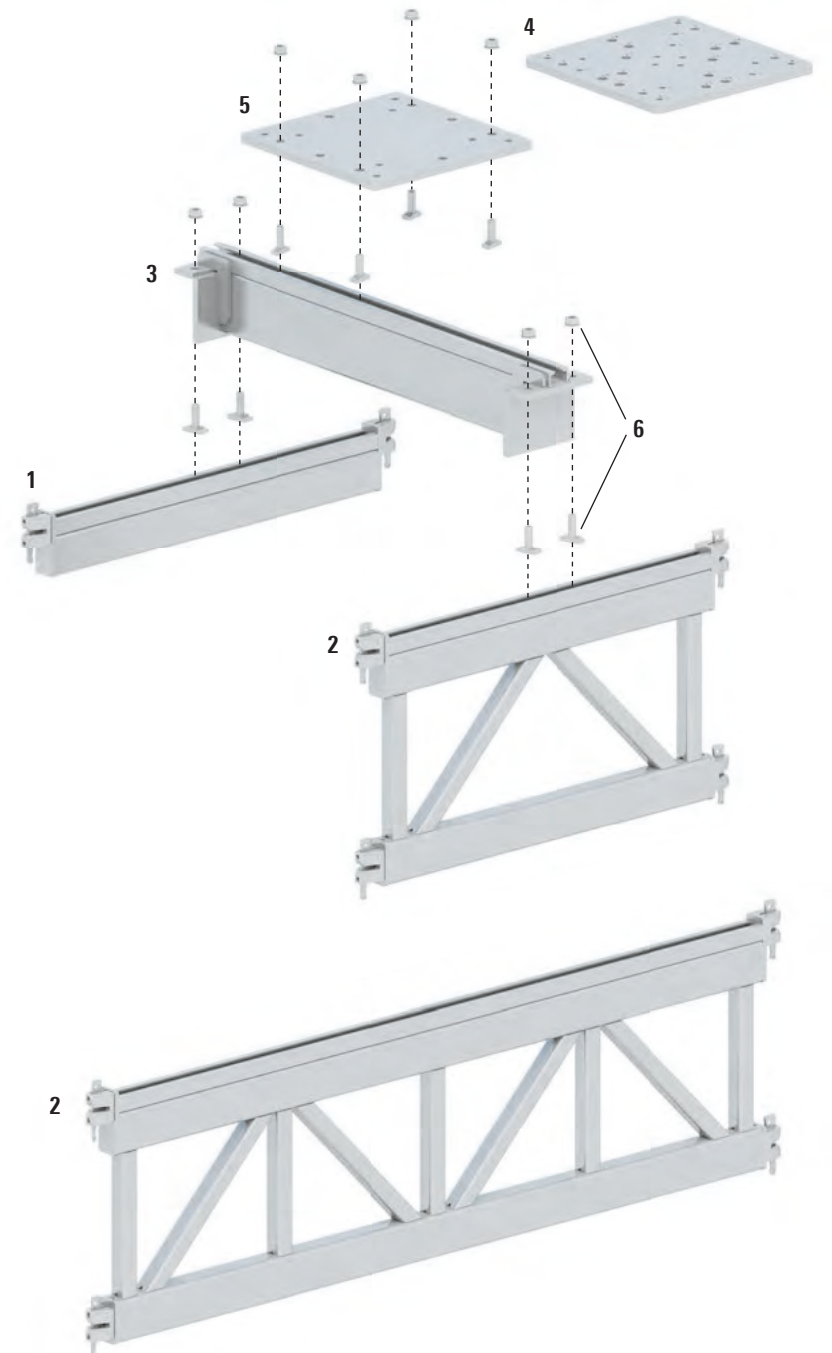

Pos.	Description	Dimensions L / H x W [m]	Weight approx. [kg]	PU [pcs.]	Ref. No.	Usable		
						EV/86	EV/100	EV/104
1	Base beam steel, hot-dip galvanized	0.86	13.0	10	5431.086	⊕	▶	
		1.00	15.5	10	5431.100	⊕		▶
		1.04	16.1	10	5431.104	⊕		▶
		2.00	32.5	10	5431.200	⊕		▶
		2.07	33.7	10	5431.207	⊕	▶	▶
2	Base beam steel, hot-dip galvanized	0.86 x 0.50	38.2	10	5432.086	⊕	▶	
		1.00 x 0.50	38.5	10	5432.100	⊕		▶
		1.04 x 0.50	39.1	10	5432.104	🏗️		▶
		2.00 x 0.50	76.0	10	5432.200	⊕		▶
		2.07 x 0.50	76.7	10	5432.207	🏗️	▶	▶
3	Truss-Transom steel, hot-dip galvanized	0.86	27.8	8	5433.086	⊕	▶	
		1.00	28.9	8	5433.100	⊕		▶
		1.04	29.0	8	5433.104	🏗️		▶
		2.00	47.3	8	5433.200	⊕		▶
		2.07	48.6	8	5433.207	🏗️	▶	▶
4	Base plate type 1 steel, hot-dip galvanized, for H30V and H40V support with 31 drillings	0.41 x 0.41	25.0	10	5434.003	⊕	▶	▶
5	Base plate type 2 steel, hot-dip galvanized, for H30V and H40V support with 16 drillings	0.41 x 0.41	25.0	10	5434.002	⊕	▶	▶
6	Special bolt , with nut HZS 53 x 34	M16 x 60	2.0	12	🏗️ 5434.013	🏗️	▶	▶

WS = wrench size PU = packaging unit 🏗️ = available ex works ⊕ = delivery time on request 🏗️ = only available in this packaging unit

LAYHER EVENT STANDS

FOR GETTING THE CROWD'S MONEY'S WORTH

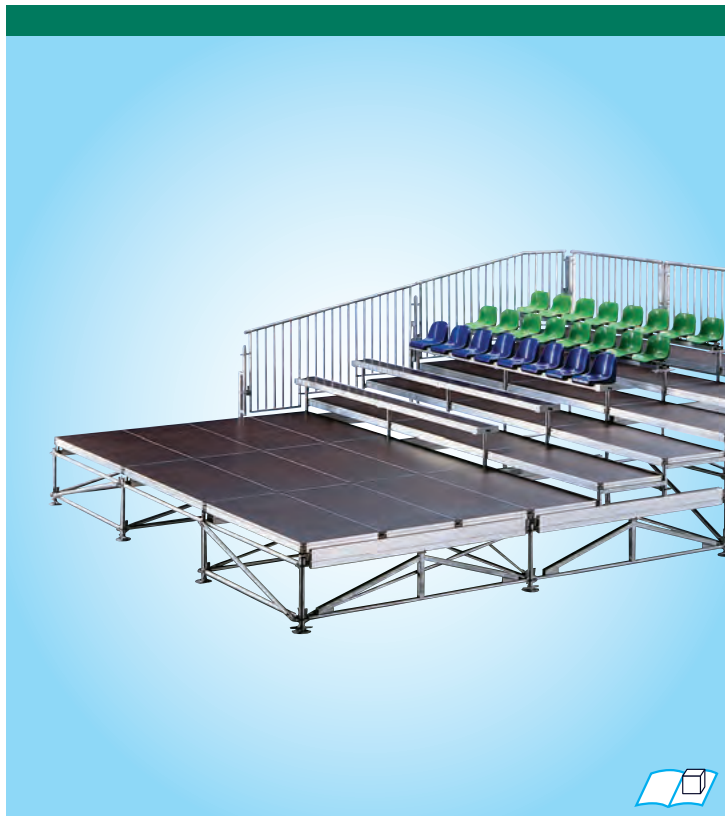

No restrictions on comfort, no limits on dimensions and equipment, no concessions to the location: Layher stands are always an excellent "observation point", just as required.

The Layher Event system: Stands for sitting, all over the world and meeting client requirements. Series manufacture and high delivery readiness are our way to help you cut costs and achieve economic success; and tailor-made special solutions whenever necessary are our strengths.

The whole Layher Event system bases on the proven Allround Scaffolding System. Thus makes investments even more economical, because the material can be used for lots of different kinds of use.

THE BENEFITS FOR YOU:

▶ Standard solutions

Series material, economical complete solutions from one source, rapid availability, proven safety.

▶ Substructure Allround

High load-bearing capacity, rapid and flexible erection and dismantling, choice of accessories.

▶ Handy components

Easy to transport and store, palletizable.

▶ Special design

For individualized problem solutions.

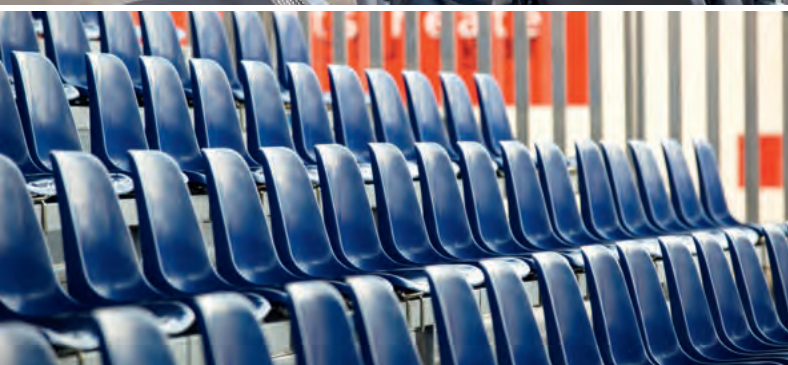

Stand components

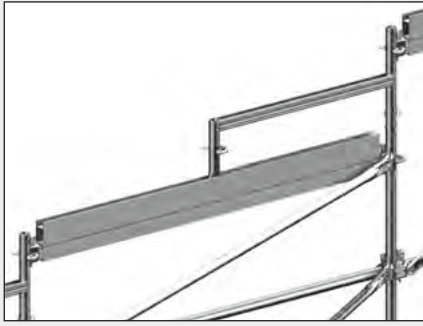

The **stand element, 1-step 1** with a standard rise of 0.25 m is used for the Event systems EV 100 and EV 104.

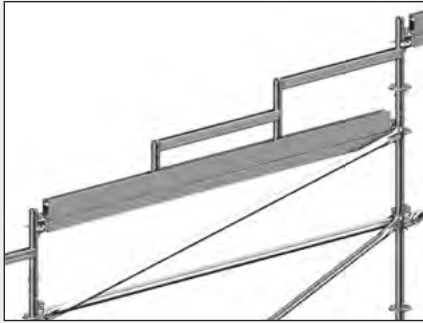

For the Event System EV 86, the **stand elements, 2-step 2** with risers of 0.16 m, 0.25 m or 0.33 m are used.

When Event decks are used, the **steel lift-off preventer 5** is required to prevent the Event decks from lifting off and tilting.

Alternatively, conventional steel decks can also be used, which is to be recommended especially for outdoor events. Here the **steel lift-off preventer 5** and the **steel deck support 7** are used.

The steel lift-off preventer is fastened using the **bolt 6**. The bolts must be ordered separately.

The **guardrail standard 0.96 m 8** with spigot fitted at the bottom is used to continue the Allround standards from the substructure. When side guardrails are used, this standard has to be additionally strengthened.



Variant for seating:

Side guardrail in the system axis



Variant for bench seat:

Side guardrail next to the system axis

The components shown here are showcase. For the different stand variants, showing in table on page 9, further stand components are available. These are stand elements, intermediate steps, guardrails and guardrail posts for each type of stand.

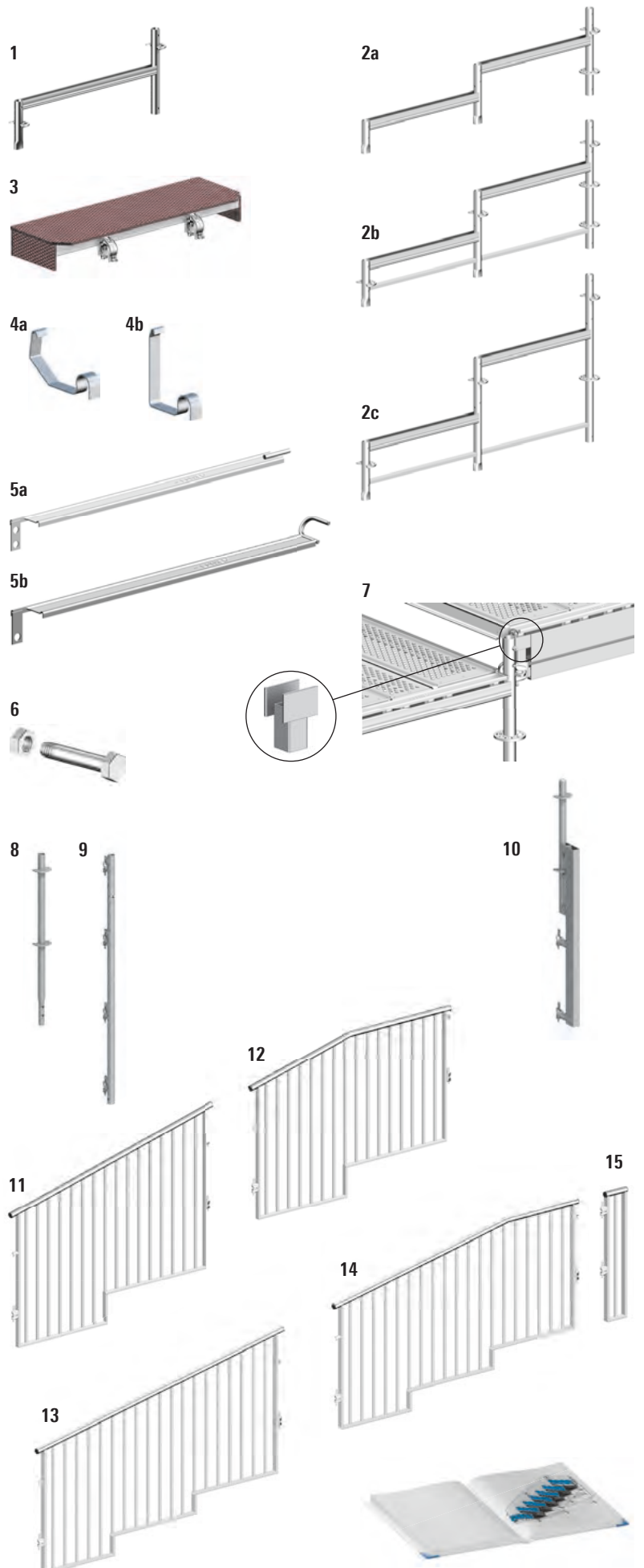

For the stands in standard-version, inspection books are available. See page 7.

Pos.	Description	Dimensions L / H x W [m]	Weight approx. [kg]	PU [pcs.]	Ref. No.	Usable			
						EV/86	EV/86Q	EV/100	EV/104
1	Stand element 1-step, inclination 0.25 m	1.00 x 0.25	6.6	40	5401.010				▶
		1.04 x 0.25	6.7	40	5401.020				▶
2a	Stand element 2-step, inclination 0.16 m	0.86 x 0.16	10.6	30	5401.216	▶	▶		
2b	Stand element 2-step, inclination 0.25 m	0.86 x 0.25	16.6	20	5401.225	⌚	▶	▶	
2c	Stand element 2-step, inclination 0.33 m	0.86 x 0.33	18.0	20	5401.233	⌚	▶	▶	
3	Intermediate step 0.30 x 0.12 x L, with 2 half couplers	L = 1.00	8.4	12	5402.110	⌚			▶ ▶
		L = 1.25	10.5	24	5402.130	⌚			▶ ▶
4a	Lock for stand element for Event deck T16		2.0	50	5403.522	▶	▶	▶	▶
4b	Lock for stand element for Event deck T10, T7, T4, T1	0.10	0.1	50	5403.501	▶	▶	▶	▶
5a	Steel lift-off preventer T19 for stand elements from 2019	0.86	1.5	50	5403.010	▶	▶		
5b	Steel lift-off preventer for stand elements to 2019	0.86	1.6	50	5403.007	⌚	▶	▶	
6	Bolt M10 x 70 , with nut for steel lift-off preventer		3.5	50	5403.011	▶	▶		
7	Steel deck support	0.10	0.4	500	5403.006	▶	▶		
8	Guardrail standard , 0.96 m with bottom mounted spigot and 2 cutaway rosettes	0.96	5.5	28	5405.045	▶	▶	▶	▶
9	Tube , 1.70 m with 4 wedge heads	1.70	8.6	50	5405.075	⌚	▶	▶	▶ ▶
10	Guardrail post for stand	1.60	14.0	20	5405.050	⌚	▶	▶	▶ ▶
11	Side guardrail T12 2-step, inclination 0.25 m	2.00 x 1.10	32.2	20	5410.201	⌚			▶
		2.07 x 1.10	32.5	25	5410.204				▶
12	Side end guardrail T12 2-step, inclination 0.25 m	2.00 x 1.10	30.4	25	5410.202	⌚			▶
		2.07 x 1.10	30.7	25	5410.206	⌚			▶
13	Side guardrail T12 3-step, inclination 0.16 m	2.57 x 1.10	35.2	25	5410.301	⌚	▶	▶	
14	Side end guardrail T12 3-step, inclination 0.16 m	2.57 x 1.10	34.3	25	5410.302	⌚	▶	▶	
15	Corner guardrail T12	0.28 x 1.10	11.2	40	5410.303	▶	▶	▶	▶

WS = wrench size PU = packaging unit 🏠 = available ex works ⌚ = delivery time on request 🧱 = only available in this packaging unit

Stand seats

You can choose the seating to suit the application, but also to suit your specific conditions. There is a choice of benches, bucket seats and tip-up seats.

Variant for bench seat:

The bench seat mounting is achieved with the **bench adapters 7**. The length of the vertical tubes is matched to the respective riser.

For the bottom row of seats, **seat supports with integrated rosette 8** are used.

The **bench 1** is 0.30 m wide and comprises anodised aluminium stiles and smooth-coated plywood.

Bench seats are secured using **wedges 5**. At the posts for side guardrails, **short wedges 6** are needed. At the ends of each row of seats, **bench ends 2** are fitted.

Novanta bucket seats 3a can be fastened to the benches. We recommend benches with predrilled holes here. The standard Novanta bucket seats are dark blue, UV-protected and flame-retardant.

The assembly material comprises per seat:

- ▶ 2 bolts with square neck
- ▶ 2 washers
- ▶ 2 nuts
- ▶ 1 plug, left
- ▶ 1 plug, right
- ▶ Number plate without lettering, white

Variant for folding seats:

Tip-up seats 9 are clamped to the **aluminium frames 10** at one point. This creates handy seat elements for rapid assembly and low transport volumes.

Aluminium frames 10 are inserted from above into the **adapters 11**. To fasten side guardrails, **standards 0.92 m with adapter 13** are used.

For the bottom row of seats, **adapters with rosette 12** are used, and on the side guardrail the **standard 1.18 m with adapter 14**.

The **aluminium frames, the adapters and standards for tip-up seats 10–14** match all three risers: 0.16 m, 0.25 m and 0.33 m.

Tip-up seats in the following colours on request:



Variant for seating:

Alternatively, already available chairs can be placed on the Event stand. The specified clear passage width inside the row of seats must be taken into account here.

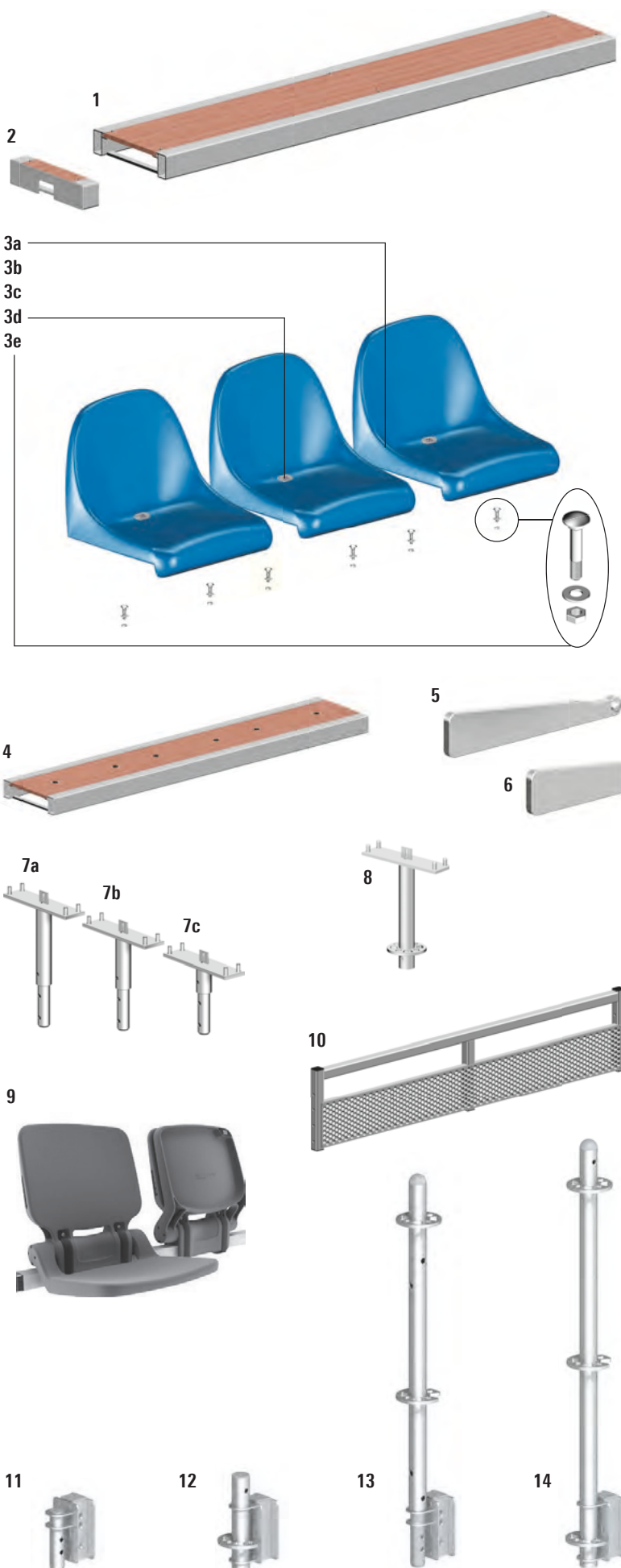

Pos.	Description	Dimensions L/H x W [m]	Weight approx. [kg]	PU [pcs.]	Ref. No.	Usable			
						EV 86	EV 86Q	EV 100	EV 104
1	Bench anodised aluminium, coated plywood	1.57 x 0.30	7.2	60	5623.157	🕒	▶	▶	
		2.00 x 0.30	9.4	60	5623.200	🏭		▶	
		2.07 x 0.30	9.5	60	5623.207	🕒	▶		▶
		2.57 x 0.30	11.7	60	5623.257	🕒		▶	
2	Bench end anodised aluminium, coated plywood	0.06 x 0.30	0.5	400	5624.000	🏭	▶	▶	▶
3a	Novanta bucket seat , blue UV-protected and flame-retardant	0.40 x 0.43	1.7	120	5408.021	🏭	▶	▶	▶
3b	Plug , left, blue		0.2	20	5408.029	🏭	▶	▶	▶
3c	Plug , right, blue		0.2	20	5408.030	🏭	▶	▶	▶
3d	Number plate , without lettering, white		0.2	20	5408.028	🏭	▶	▶	▶
3e	Assembly-Set for 20 bucket seats existing of 40 bolts M8 x 40, 40 nuts and 40 washers		1.2	40	5408.008	🏭			
4	Bench , with holes for Novanta bucket seats	1.57 x 0.30	7.2	60	5408.157	🕒	▶	▶	
		2.07 x 0.30	9.5	60	5408.207	🏭	▶		▶
		2.57 x 0.30	11.7	60	5408.257	🏭		▶	
5	Allround wedge , steel, for securing bench	0.14	5.0	50	6494.816	🕒		▶	▶
			12.0	100	6494.901	🏭		▶	▶
6	Allround wedge , short, 90 mm without holes, for securing bench at edge of stand	0.09	1.0	10	6494.041	🏭		▶	▶
7a	Bench adapter , inclination 0.16m	0.42	3.7	100	5406.010	🏭	▶	▶	
7b	Bench adapter inclination 0.25m	0.34	3.4	100	5406.015	🏭		▶	▶
7c	Bench adapter , inclination 0.33m	0.26	3.1	100	5406.020	🕒		▶	▶
8	Seat support with rosette for bottom rows	0.34	4.0	60	5619.000	🕒	▶	▶	▶
9	Tip-up seat , black UV-protected and flame-retardant	0.48 x 0.42	3.2	60	5515.001	🏭	▶	▶	▶
10	Aluminium frame for tip-up seats suitable for all inclinations	1.50 x 0.43	7.4	30	5516.150	🕒		▶	
		1.57 x 0.43	7.6	30	5516.157	🕒	▶	▶	▶
		2.00 x 0.43	9.4	30	5516.200	🕒		▶	
		2.07 x 0.43	9.7	30	5516.207	🏭	▶		▶
		2.50 x 0.43	11.6	30	5516.250	🕒		▶	
		2.57 x 0.43	11.8	30	5516.257	🕒		▶	
11	Adapter with spigot	0.17	2.8	150	5521.001	🏭	▶	▶	▶
12	Adapter with rosette for lowest stand row	0.26	3.5	150	5521.002	🕒	▶	▶	▶
13	Standard 0.92 m with adapter for guardrail mounting	0.92	7.8	150	5521.003	🕒	▶	▶	▶
14	Standard 1.18 m with adapter for guardrail mounting at the lowest stand row	1.18	7.9	50	5521.004	🕒	▶	▶	▶

WS = wrench size PU = packaging unit 🏭 = available ex works 🕒 = delivery time on request 📦 = only available in this packaging unit

FOH TOWER

TOWERS FOR EVERY EVENT IN MODULAR DESIGN



The Layher FOH Tower kit system provides you with the right solution for your Front-Of-House applications. To meet the most frequently encountered requirements, a total of 12 FOH Tower complete KITS are available.

ONE SYSTEM – MANY VARIANTS

The kit System and Layher's flexible Allround equipment offers an impressive variability.

Whether it's a 2 or 3 bay width, with or without a projecting roof and entrance, with 1, 2 or 3 storeys. The Layher FOH Tower kit System means more possibilities. Typical for Layher!

THE BENEFITS FOR YOU:

- ▶ Quick and easy assembly thanks to optimum use of material.
- ▶ Neat and practically-minded design down to the last detail.
- ▶ Each of the maximum of three levels is without a hindering central support.
- ▶ Complete enclosure using keder tarpaulins.
- ▶ Very few special parts.
- ▶ Two inspection books available: 4.14 m x 4.14 m (4x4) and 6.21 m x 4.14 m (6x4).

VIDEO WALL



To give all of the audience a closer look at the performers at major open-air concerts, and also because the broadcasting of major sporting events like the FIFA World Cup is increasingly evolving into a spectacle for the entire public, LED video screens have now become essential.

But since not every concert and not every fan community makes the same demands of a video screen, and the LED displays made up of several panels can be flexibly adjusted in size to suit actual needs, Layher has designed its Video Wall System for easy adaptation to requirements on the spot.

THE BENEFITS FOR YOU:

- ▶ High degree of planning certainty and simplicity, by covering many application scenarios with one system and by rapid material availability.
- ▶ High degree of legal security, thanks to the inspection book provided in accordance with DIN EN 13814 and covering all system variants. Stability is verified for up to wind zone 4. The video screen does not have to be removed in strong winds (display panel manufacturer's specifications must be complied with).
- ▶ Quick and easy assembly without a crane, thanks to bolt-free pin and wedge connection technology.

PA TOWER PLUS

SIDE STAGES

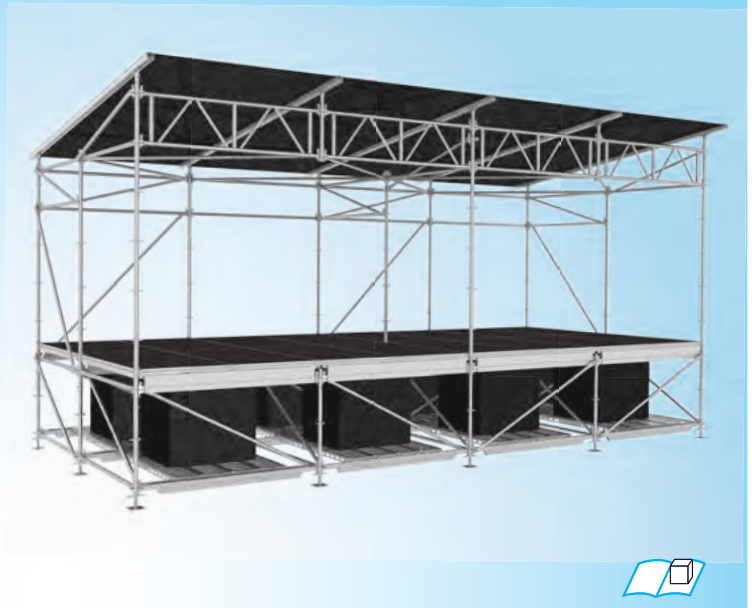
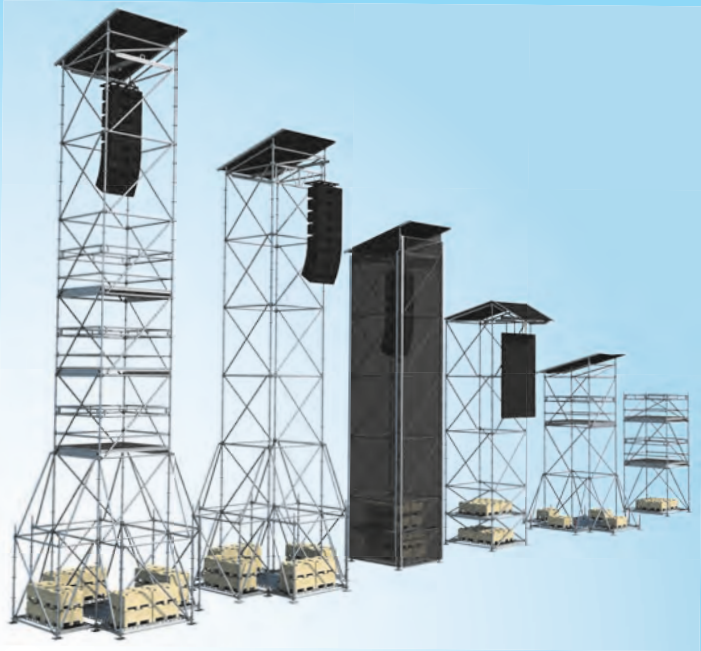

Compared with one-off solutions devised for specific projects, the PA-Tower PLUS is not only quick to deliver due to the use of Allround standard components, and efficient to assemble.

Depending on requirements, more than 300 pre-configured variants in various heights and widths are possible with the Allround construction kit. An extensive structural report is available for all these variants.

The applications range from classic loudspeaker towers and camera / directing towers to towers for lighting or advertising.

THE BENEFITS FOR YOU:

- ▶ Modular design, based on the Allround construction kit.
- ▶ Economical to assemble thanks to bolt-free wedge and pin connections.
- ▶ Minor logistic effort thanks to small packing dimensions.
- ▶ Planning and scheduling certainty thanks to availability of a structural report with more than 300 different variants.
- ▶ Investments are protected by new application possibilities for existing material without major additional investments.

Structural strength calculations and inspection books for smaller open-air stages and mobile stages usually ignore a technical area positioned at the side or behind the stage floor. This technical area is needed for preparing and storing technical equipment and instruments. Unlike expensive one-off solutions, side attachments for stages using Allround Scaffolding are considerably faster to build, making them more economical too.

To assist its clients even during the planning phase, Layher has verified the stability for a range of different configurations.

THE BENEFITS FOR YOU:

- ▶ No need to invest in individual structural analyses for Side Stages.
- ▶ Safety under the law from available verification of stability.
- ▶ Added value of existing material – new application options without additional investment.
- ▶ Well thought-out system solution using rapidly available standard Allround Scaffolding parts.
- ▶ Quick and easy building manually. No crane is needed.

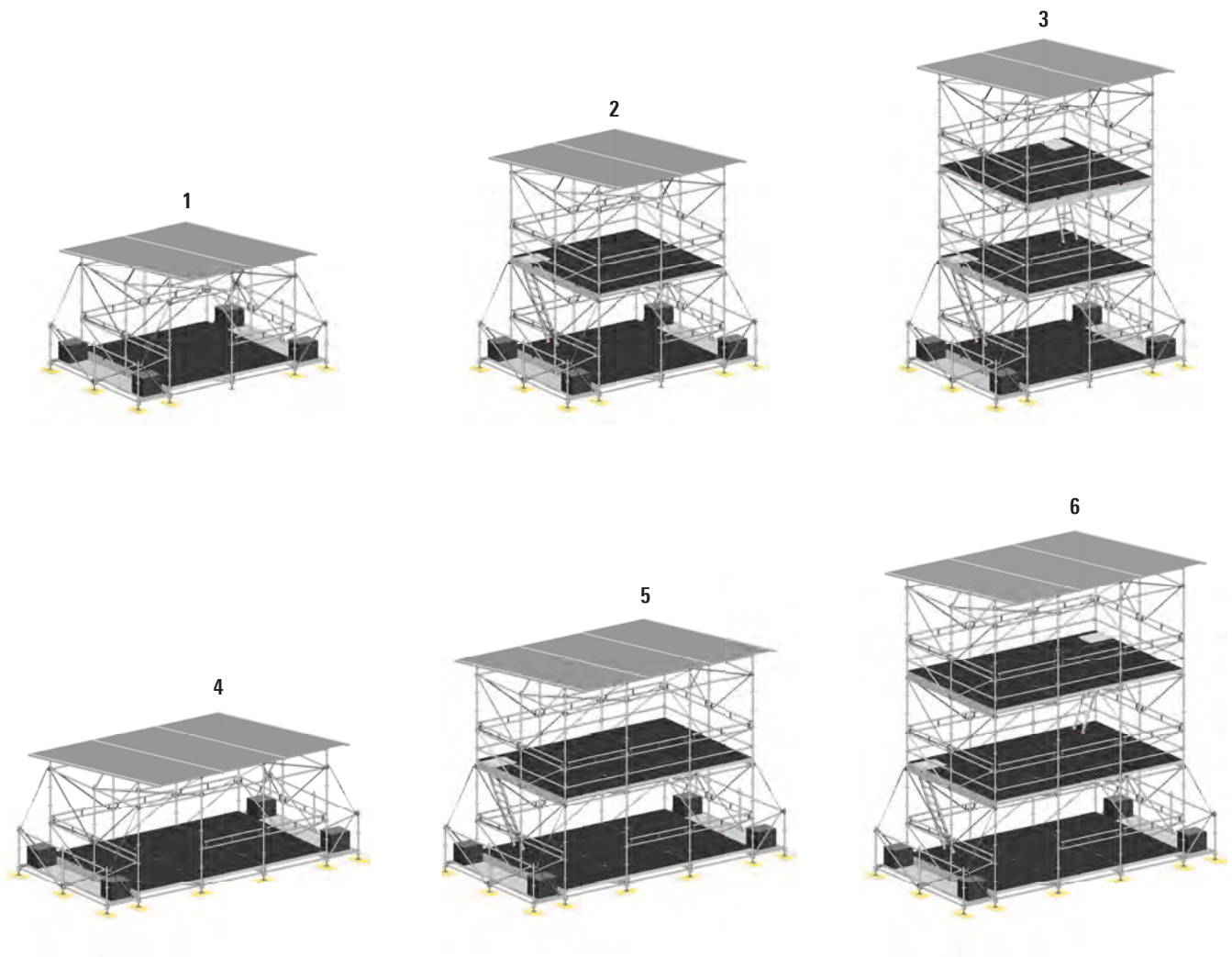

The Layher FOH Towers are of modular design in a kit system. To add a further storey to your FOH tower, it's only necessary to adjust the number of parts, but not their type. The optionally available projecting roofs and the optional entrance steps can be easily mounted if required.



For all the shown variants of the FOH tower, an inspection book is available. See page 7.

The construction complies with DIN EN 13814, which reflects the current state of the art. The Layher FOH tower is available in the well-known Layher grid dimensions and in metric dimensions.

The wall coverings (rear wall and side walls) are available as a separate kit for all FOH towers variants. These consist of: keder rail holders, keder rails 2000, keder tarpaulins and gable tarpaulins.

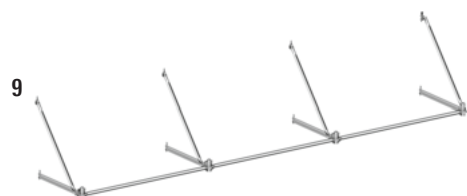

Pos.	Description	Dimensions L/H x W [m]
1a	FOH Tower with 1 storey including roof tarpaulins	4.00 x 4.00
	Wall covering for FOH tower 1a	
1b	FOH Tower with 1 storey including roof tarpaulins	4.14 x 4.14
	Wall covering for FOH tower 1b	
2a	FOH Tower with 2 storeys including roof tarpaulins	4.00 x 4.00
	Wall covering for FOH tower 2a	
2b	FOH Tower with 2 storeys including roof tarpaulins	4.14 x 4.14
	Wall covering for FOH tower 2b	
3a	FOH Tower with 3 storeys including roof tarpaulins	4.00 x 4.00
	Wall covering for FOH tower 3a	
3b	FOH Tower with 3 storeys including roof tarpaulins	4.14 x 4.14
	Wall covering for FOH tower 3b 5060.472	
4a	FOH Tower with 1 storey including roof tarpaulins	6.00 x 4.00
	Wall covering for FOH tower 4a	
4b	FOH Tower with 1 storey including roof tarpaulins	6.21 x 4.14
	Wall covering for FOH tower 4b	
5a	FOH Tower with 2 storeys including roof tarpaulins	6.00 x 4.00
	Wall covering for FOH tower 5a	
5b	FOH Tower with 2 storeys including roof tarpaulins	6.21 x 4.14
	Wall covering for FOH tower 5b	
6a	FOH Tower with 3 storeys including roof tarpaulins	6.00 x 4.00
	Wall covering for FOH tower 6a	
6b	FOH Tower with 3 storeys including roof tarpaulins	6.21 x 4.14
	Wall covering for FOH tower 6b	
7	FOH entrance	2.00
		2.07
8	FOH projecting roof for 2 bays including tarpaulin	4.00
		4.14
9	FOH projecting roof for 3 bays including tarpaulin	6.00
		6.21

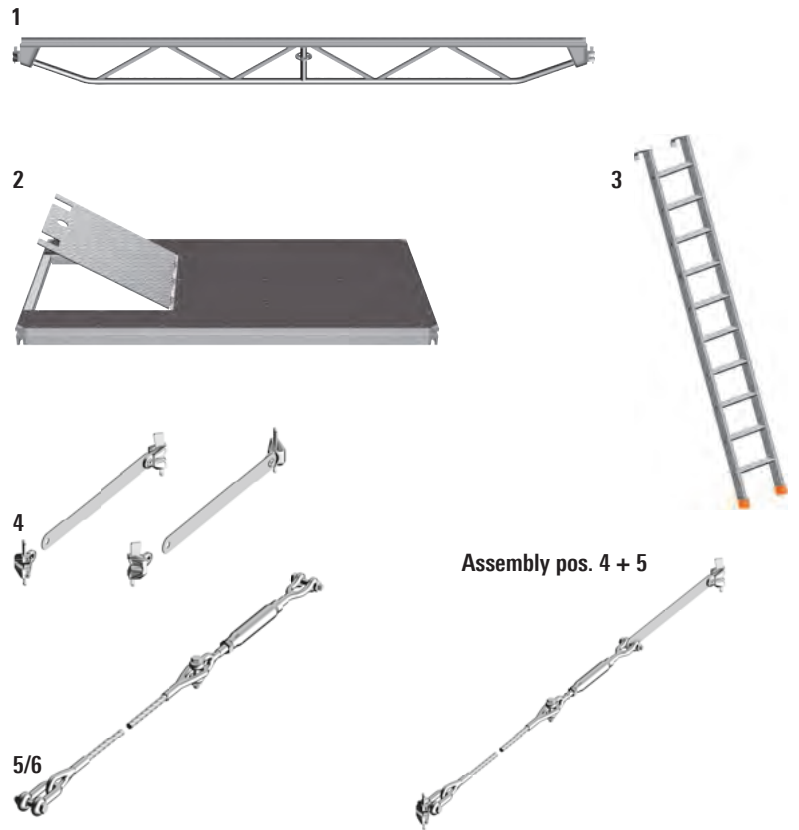

Roof and wall cladding

The proven **keder rail 2000 7**. Known for its low weight. Ideal for lightweight applications, particularly for wall coverings and scaffolding covers.

The **keder rail 3000 8** – very strong yet light. It is perfectly suited for medium spans, as found for example in FOH and directing towers or in technical equipment and storage areas. The keder rail 3000 can also be used as a wall keder rail over large spans.

The **keder rail 9000 9** is suitable as a heavy-duty marquee section for large and very large spans. Roofs and side coverings for large open-air stages can be constructed with this section, in addition to massive roofs for stands.

The **keder rails 7, 8 and 9** are suitable for keder tarpaulins with a keder of 13 mm.

When using the **keder rails 7 and 8**, standard tarpaulins from the protective system range **can be used**. **When using the keder rail 8**, the tarpaulins must 29 mm narrower. We offer suitable material upon request.

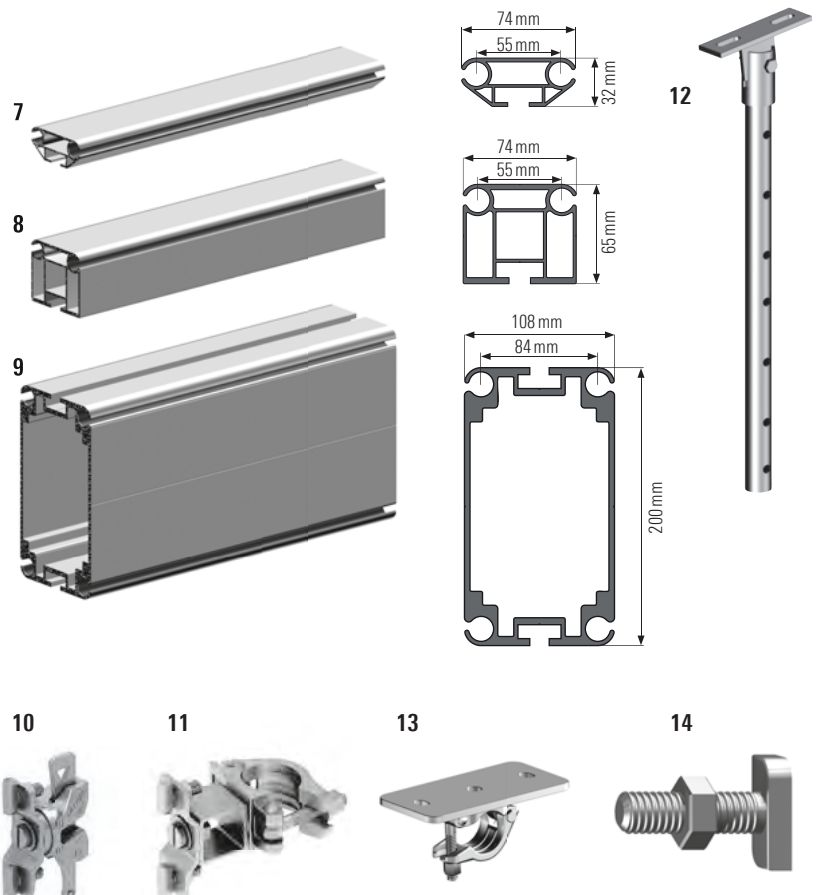

Pos.	Description	Dimensions L/H x W [m]	Weight approx. [kg]	PU [pcs.]	Ref. No.	Usable		
						EV/86	EV/100	EV/104
1	FOH beam	4.00	38.1	20	5573.010		▶	
		4.14	38.6	20	5573.011			▶
2	Event access deck T16 with aluminium hatch	0.86 x 2.07	33.9	10	5402.221	🕒	▶	
		1.00 x 2.00	36.3	10	5402.222	🕒		▶
		1.04 x 2.07	38.0	10	5402.223	🕒		▶
3	Single step ladder, with hook 10-steps for storey height 2.50 m	2.70 x 0.45	7.7	10	5573.021		▶	▶
4	FOH rope holder set 4 parts for connection of the ballast bays		2.7	100	5573.002		▶	▶
5	Rope fastener for ballast bays	1.22	1.3	10	5573.005	🕒	▶	▶
6	Rope fastener for roof stiffening	as HD 4.00 x 4.00 m	5.57	10	5573.003	🕒	▶	▶
		as HD 4.14 x 4.14 m	5.77	10	5573.004	🕒	▶	▶

Pos.	Description	Dimensions L/H x W [m]	Weight approx. [kg]	PU [pcs.]	Ref. No.
7	Aluminium keder rail 2000 for side tarpaulins	1.30	2.0	50	4201.130
		2.00	3.0	50	4201.200
		2.25	3.3	50	4201.220
		2.50	3.8	50	4201.250
		3.00	4.5	50	4201.300
		4.00	6.0	50	4201.400
		6.00	9.0	50	4201.600
8	Aluminium keder rail 3000 for roof tarpaulins	2.00	6.1	20	5574.200
		3.00	9.2	20	5574.300
		4.00	12.2	20	5574.400
		5.00	15.3	20	5574.500
		6.00	18.3	20	5574.600
9	Aluminium keder rail 9000	5.00	54.8	10	5577.500
		6.00	65.8	10	5577.600
		9.00	98.7	10	5577.900
10	Keder rail holder, rotatable, incl. 2 captive bolts		0.9	25	5573.000
11	Keder rail holder, rotatable, with half-coupler, incl. 2 captive bolts		1.0	25	5573.006
12	Hinged attachment for Event roof		3.4	25	5573.001
13	Half-coupler, with plate	0.20 x 0.10	2.1	25	5573.030
14	Captive bolt for keder rail M12 x 40, with nut, for Pos. 7, 9, 12 and 13		5.0	50	4206.003
		M12 x 40, with nut, spare part for Pos.10 and 11	4.3	50	4206.004

WS = wrench size PU = packaging unit 🏠 = available ex works 🕒 = delivery time on request 🏠 = only available in this packaging unit

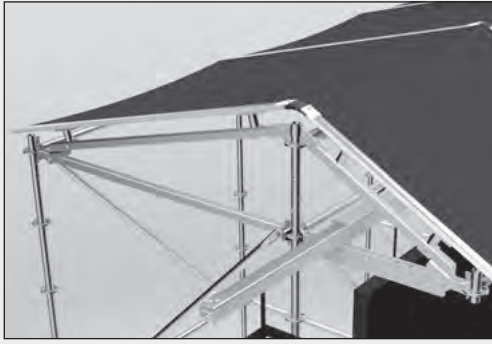

Product advantages:

- ▶ Modular design based on Layher Allround Scaffolding
- ▶ Manual assembly
- ▶ Economical to assemble thanks to wedge and pin connections
- ▶ Low transport volume
- ▶ Expandable with additional functions
- ▶ Roofing
- ▶ Enclosure
- ▶ Table / podium
- ▶ Projecting arm for PA

The load bracket consists of five parts connected to one another with **pins 12**. The **standard 0.50 m 1** has two different receiving plates for fastening the **diagonal braces 3** and **5**. At the top level of the scaffolding wall, one **ledger 4** is used. The projecting **U-ledger 2** can receive the **load beams 6** from both sides.

At the ends of the video screen, **projecting arms 8** can be laterally inserted to support the loads of up to 5 kN. The necessary M12 x 130 bolts are supplied together with the projecting arm.

A roof can be constructed optionally.





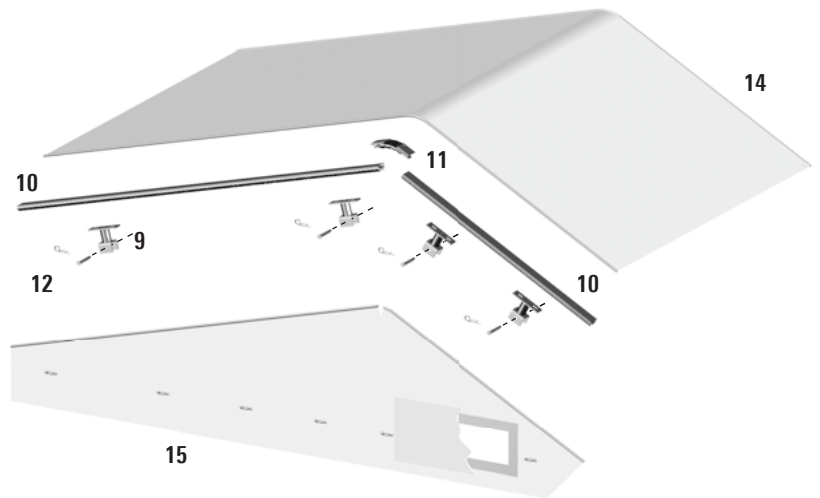
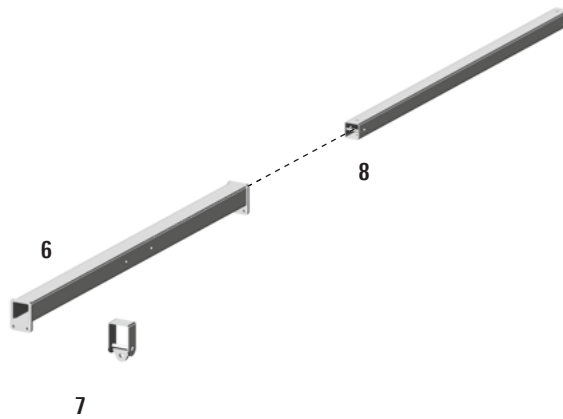
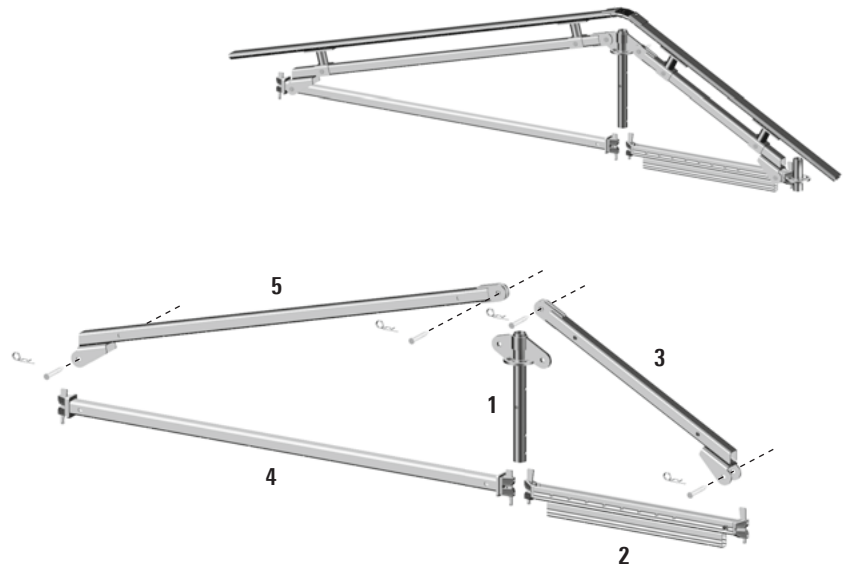
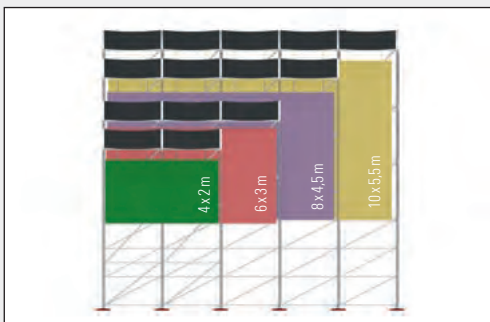









To do so, the **keder holders 9** are fastened by means of **pins 12** into the holes provided for them in the **diagonal braces 3** and **5**.

To fix the keder rails, **groove bolts for keder rail, Ref. No. 4206.001**, are needed, see pages 30–31.



For the pre-defined variants of the video wall system, an inspection book can be ordered. See page 7.

Other lengths for the keder rails and further accessory parts can be found in our price list for Non-System Accessories.

Pos.	Description	Dimensions L/H x W [m]	Weight approx. [kg]	PU [pcs.]	Ref. No.		
1	Video Wall standard, 0.50 m	0.50	4.5	100	5435.050		
2	Video Wall U-ledger	1.00	6.2	50	5435.100		
		1.04	6.3	50	5435.104		
3	Video Wall diagonal brace, square tube, short for video wall U-ledger 1.00 and 1.04 m	1.01	7.1	100	5435.030		
4	Video Wall ledger, square tube	2.00	12.4	50	5435.201		
		2.07	12.8	50	5435.208		
5	Video Wall diagonal brace, square tube, long for video wall ledger 2.00 and 2.07 m	1.93	12.4	50	5435.035		
6	Load beam	1.00	17.1	10	5435.010		
		1.04	17.6	10	5435.014		
		2.00	32.2	10	5435.020		
		2.07	33.3	10	5435.027		
7	Suspension point	0.10x0.10	2.1	200	5435.210		
8	Video Wall PA projecting arm	2.00	23.8	20	5435.055		
9	Video Wall keder holder	0.075	1.3	100	5435.215		
10	Aluminium keder rail 2000	1.30	2.0	50	4201.130		
		2.25	3.3	50	4201.220		
11	Aluminium keder bend flexible, short	0.16	0.5	20	4205.004		
12	Video Wall pin, 16 x 121 mm		0.2	250	5435.310		
13	Safety clip, 4.0 mm		1.5	50 	5905.002		
14	Video Wall roof tarpaulin	black	2.00x3.68	6.9	10	5435.320	
		white	2.00x3.68	6.9	10	5435.321	
		black	2.07x3.68	7.2	10	5435.327	
		white	2.07x3.68	7.2	10	5435.328	
15	Video Wall gable tarpaulin	black	3.45x0.90	2.7	10	5435.330	
		white	3.45x0.90	2.7	10	5435.331	

WS = wrench size PU = packaging unit  = available ex works  = delivery time on request  = only available in this packaging unit

PA Tower PLUS

Towers for loudspeakers, camera equipment or lighting are essential at every sporting and cultural event.

Depending on requirements, more than 300 pre-configured variants in various heights and widths are possible



An extensive structural report is available for all these variants.

Two surface areas are available – 2.07 x 2.07 m and 4.14 x 4.14 m or 2.00 x 2.00 m and 4.00 x 4.00 m – plus heights from 4.7 to 14.7 metres.

Roofs and enclosures using tarpaulins or the Protect System that quickly fits onto Allround Scaffolding cater to every requirement.

The stability of the PA-Tower PLUS was structurally verified in accordance with the current standard DIN EN 13814: with and without a wind strength limit up to Wind Zone 4 – both with and without covering.

This means that time-consuming and cost-intensive structural analyses for individual towers are no longer needed, considerably reducing the project handling workload.

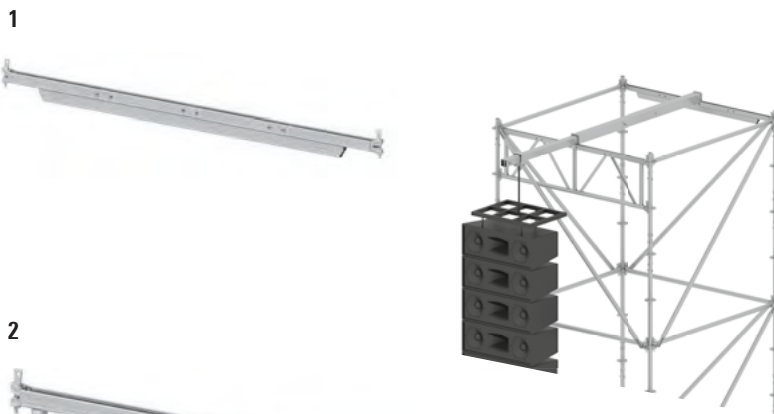
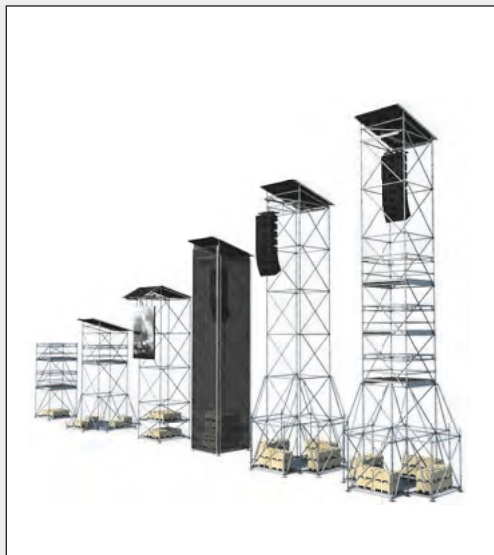

Example for use:

- ▶ Ground plan 4 x 4 m
- ▶ 3 work levels
- ▶ Video wall bracket
- ▶ Cantilever for loudspeakers
- ▶ Roofing



Pos.	Description	Dimensions L / H x W [m]	Weight approx. [kg]	PU [pcs.]	Ref. No.
1	PA Tower PLUS U-ledger	2.00	12.5	50	5435.200
		2.07	12.7	50	5435.207
2	PA Tower PLUS U-lattice beam	2.00	20.9	40	5436.200
		2.07	21.4	40	5436.207

WS = wrench size PU = packaging unit = available ex works = delivery time on request = only available in this packaging unit

LAYHER STEEL TRUSS SYSTEMS

ENORMOUSLY BEARING, HUGE SPANS, FOR DIFFERENT SCOPES OF APPLICATION



Constructions, which are made to carry high loads and however must be easy and fast to assemble, need well-thought and strong components. Layher offers with the new steel truss the right tools for that challenge.

THE BENEFITS FOR YOU:

- ▶ Attractive outer dimensions.
- ▶ High load-bearing capacity.
- ▶ Large spans.
- ▶ Quick assembly thanks to well-known fork-connectors.
- ▶ Low bending.

Steel Truss System

Constructions, which are made to carry high loads and however must be easy and fast to assembly, need well-thought and strong components. Layher offers with the new steel truss the right tools for that challenge.

If needed, order the free available system statics for the truss systems. These contain load tables and all relevant data for your planning office.

Tower Truss 1

The Layher Tower truss is suitable for use as a vertical support for structures with horizontal Maxi-Truss beams.

Examples of use:

Ground support, advertising panel and cable bridge.

Maxi Truss 2

The Maxi Truss is a very strong transom type, which is especially usable for roofings as main transom, as ground support, for advertisement signs or cable bridges.

Nova Truss 3

The Layher Nova truss is suitable for use as a vertical support for structures with horizontal Super-Truss beams.

Examples of use:

Ground support, advertising panel and cable bridge.

Super Truss 4

The Super Truss is a very strong transom type, which is usable for roofings as main transom, as ground support, for advertisement signs or cable bridges.

The steel truss elements are connected to one another using bolts 5/6. The bolts intended for this purpose must be ordered separately.

The steel truss elements will be produced individually according to your requirements. Do not hesitate to ask us! We are pleased to help you.

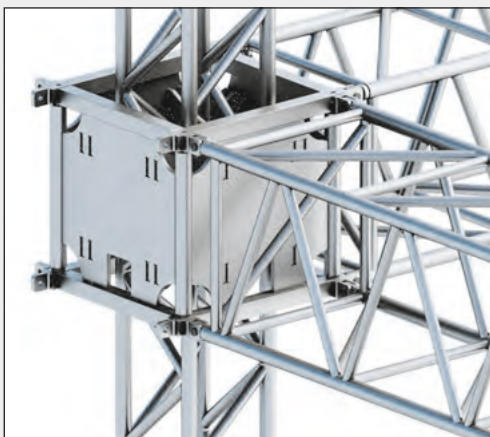

Corner elements and sleeve blocks on request.

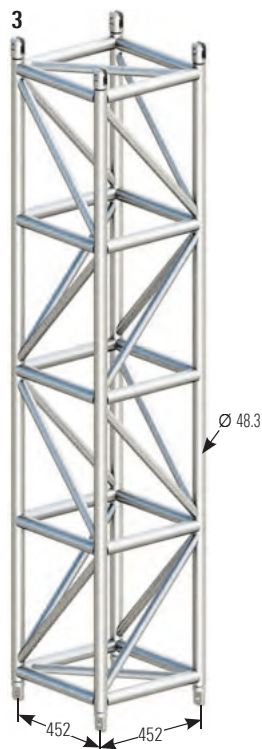

5/6



7/8

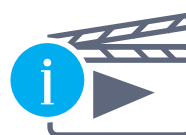

MORE INFORMATION

Further information about load-bearing capacity can be found in the Layher Info Steel Truss

Pos.	Description	Dimensions L/H x W [m]	Weight approx. [kg]	Weight per metre approx. [kg]	PU [pcs.]	Ref. No.
1	Tower Truss , steel, hot-dip galvanized, axial dimensions 299 x 299 mm. Usable for roofings as vertical support for constructions of Maxi Truss, as ground support, advertisement signs or cable bridges, use with bolt dia. 15.8 mm	0.50	23.0	46.0		on request
		1.00	37.0	37.0		
		1.50	50.3	33.5		
		2.00	67.3	33.7		
		2.40	81.0	33.8		
		3.00	98.0	32.7		
		4.00	127.7	31.9		
		5.00	152.6	30.5		
2	Maxi Truss , steel, hot-dip galvanized, axial dimensions 569 x 569 mm. Usable for roofings as main transom, as ground support, for advertisement signs or cable bridges, use with bolt dia. 15.8 mm	0.25	21.6	86.4		on request
		0.50	33.0	66.0		
		1.00	53.4	53.4		
		1.20	57.8	48.2		
		1.80	79.5	44.2		
		2.07	91.0	44.0		
		2.40	99.2	41.3		
		3.00	120.0	40.0		
		4.00	156.9	39.2		
		5.00	191.0	38.2		
3	Nova Truss , steel, hot-dip galvanized, axial dimensions 452 x 452 mm. Usable for roofings as vertical support for constructions of Super Truss, as ground support, for advertisement signs or cable bridges, use with bolt dia. 15.8 mm	1.04	58.0	55.8		on request
		1.50	78.0	52.0		
		2.07	102.0	49.3		
		2.40	109.3	45.5		
		2.57	123.0	47.9		
		3.00	142.5	47.5		
		4.00	184.9	46.2		
		5.00	227.4	45.5		
		6.00	270.0	45.0		
4	Super Truss , steel, hot-dip galvanized, axial dimensions 550 x 854 mm. Usable for roofings as main transom, as ground support, for advertisement signs or cable bridges, use with bolt dia. 20.0 mm	1.00	84.5	84.5		on request
		1.57	111.5	71.0		
		2.07	139.0	67.1		
		2.40	143.0	59.6		
		3.00	187.6	62.5		
		3.50	206.3	58.9		
		4.00	239.0	59.8		
		4.14	245.0	59.2		
		5.00	291.2	58.2		
		5.50	324.5	59.0		
5	Bolt , 15.8 x 80.0 mm for Tower Truss, Nova Truss and Maxi Truss		0.7		4	5550.003
6	Bolt , 20.0 x 100.0 mm for Super Truss		1.3		4	5550.004
7	Safety clip , 2.8 mm for Tower Truss, Nova Truss and Maxi Truss		0.5		50	4905.002
8	Safety clip , 4.0 mm for Super Truss		1.5		50	5905.002

WS = wrench size PU = packaging unit = available ex works = delivery time on request = only available in this packaging unit

Index

A

Adapter with rosette	25
Adapter with spigot	25
Allround Scaffolding	12
Allround wedge	25
Aluminium frame for tip-up seats	25
Aluminium keder rail	31
Assembly-Set for 20 bucket seats	25

B

Base beam	19
Base collar	13
for modular stairway	17
Base plate	13, 19
Basic components	14
Bench	25
Bench adapter	25
Bench end	25
Bolt	37
Bolt M10 x 70	23
Bucket seat	25

C

Captive bolt	
for keder rail	31
Clamp	15
Corner guardrail	23

D

Diagonal brace LW	13
-------------------	----

E

Event access deck	31
Event deck T16	15
Event stages	10
Event stands	20
Event transom	15

F

FOH beam	31
FOH entrance	29
FOH projecting roof	29
FOH rope holder set	31
FOH System	28, 30
FOH Tower	29

G

Guardrail	
for modular stairway	17
with child safety features	16
Guardrail post	
for podium	17
for stand	23
Guardrail standard	23

H

Half-coupler	
with plate	31
Handrail	17
Hinged attachment for Event roof	31
Hinged pin	13

I

Inspection book	7
Intermediate step	23

K

Keder bend flexible	33
Keder rail	31, 33
Keder rail holder	31

L

LayPLAN	6
Lift-off preventer	17
Load beam	33
Lock for stand element	23

M

Maxi Truss	37
------------	----

N

Nova Truss	37
Number plate	25

O

O-ledger	
LW	17
O-ledger LW	13
horizontal-diagonal, steel	13

P

PA Tower PLUS	34
PA Tower PLUS U-lattice beam	34
PA Tower PLUS U-ledger	34
Plastic corner	15
Plug	25
Podiums	8, 10

R

Roof cladding	30
Rope fastener	31
Rubber pad	
for base plate	13

S

Safety clip	33, 37
Seating stand	9
Seat support with rosette	25
Side end guardrail	23
Side guardrail	23
Single step ladder	31
Software for scaffolding construction	6
Special bolt	
HZS 53 x 34, with nut	19
M12 x 60, with nut	13
Spigot	13
Square half-coupler	15
Stairway guardrail 750	
with child safety feature	17
Stairways	16
Standard	
0.92 m with adapter	25
1.18 m with adapter	25
for modular stairway	17
Standard lock	13
Stand components	22
Stand element	
1-step, 2-step	23
Stands	9, 20
Stand seats	
Variant for bench seat	24
Variant for folding seats	24
Stand Systems	8
Steel deck support	23
Steel lift-off preventer	23
Steel Truss System	36
Stringer for modular stairway	16, 17
Super Truss	37
Suspension point	33

T

Tension clasp	15
Tip-up seat	25
Tower Truss	37
Transom support	15
Truss Systems	
Steel	35
Truss-Transom	19
Tube	23

U

Universal Base	18
U-Stairway stringer 750 with half-coupler	17

V

Video Wall diagonal brace	33
Video Wall gable tarpaulin	33
Video Wall keder holder	33
Video Wall ledger	33
Video Wall PA projecting arm	33
Video Wall pin	33
Video Wall roof tarpaulin	33
Video Wall standard	33
Video Wall System	32
Video Wall U-ledger	33

W

Wall cladding	30
---------------	----

X

X-Event deck T16	15
------------------	----

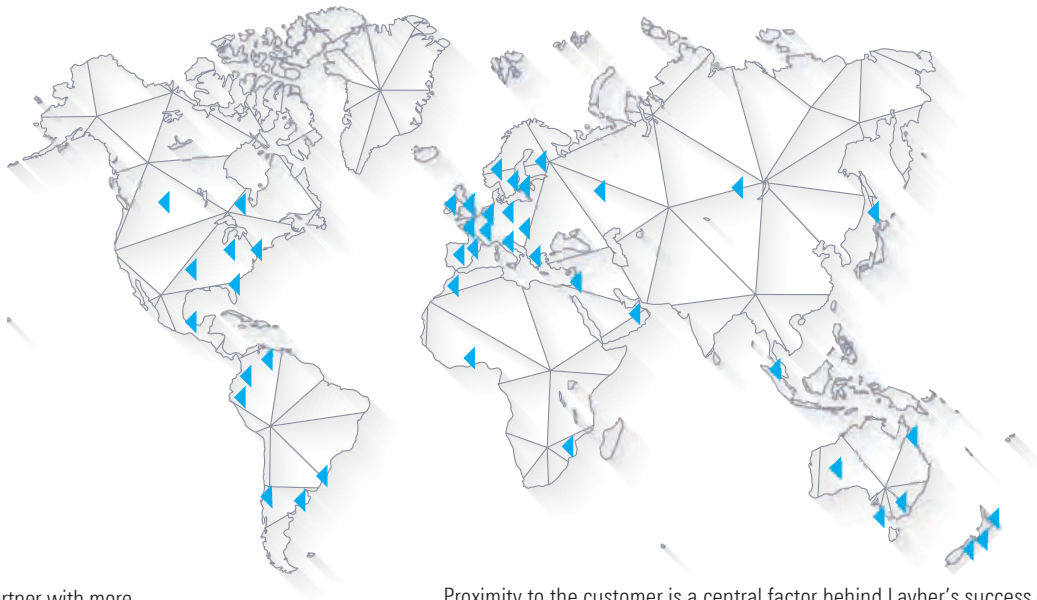

Layher is your dependable partner with more than 75 years of experience. "Made by Layher" always means "Made in Germany" too – and that goes for the entire product range. Superb quality – and all from one source.

Proximity to the customer is a central factor behind Layher's success – geographically speaking too. Wherever our customers need us, we will be there – with our advice, assistance and solutions.

-  **SpeedyScaf**
-  **Allround Scaffolding**
-  **System-free Accessories**
-  **Protective Systems**
-  **Shoring**
-  **Event Systems**
-  **Rolling Towers**
-  **Ladders**
-  **Software**



Headquarters in Eibensbach



Plant 2 in Gueglingen

Layher 
 More Possibilities. The Scaffolding System.

Wilhelm Layher GmbH & Co KG
 Scaffolding Grandstands Ladders
 Ochsenbacher Strasse 56
 74363 Gueglingen-Eibensbach
 Germany

Post Box 40
 74361 Gueglingen-Eibensbach
 Germany
 Telephone +49 (0) 71 35 70-0
 Telefax +49 (0) 71 35 70-2 65
 E-mail export@layher.com
www.layher.com

