



EclExpo Flood300VW

300W asymmetric LED floodlight, with
Variable White CCT 2,700K - 6,500K



USER MANUAL

Thank you for choosing PROLIGHTS

Please note that every PROLIGHTS product has been designed in Italy to meet quality and performance requirements for professionals and designed and manufactured for the use and application as shown in this document.

Any other use, if not expressly indicated, could compromise the good condition/operation of the product and/or be a source of danger.

This product is meant for professional use. Therefore, commercial use of this equipment is subject to the respectively applicable national accident prevention rules and regulations.

Features, specifications and appearance are subject to change without notice. Music & Lights S.r.l. and all affiliated companies disclaim liability for any injury, damage, direct or indirect loss, consequential or economic loss or any other loss occasioned by the use of, inability to use or reliance on the information contained in this document.

Product user manual can be downloaded from the website www.prolights.it, or can be inquired to the official PROLIGHTS distributors of your territory (https://www.prolights.it/sales_network.html).

Scanning the below **QR Code**, you will access the download area of the product page, where you can find a broad set of always updated technical documentation: specifications, user manual, technical drawings, photometrics, personalities, fixture firmware updates.

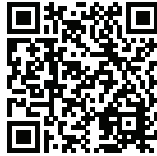

Visit the download area
of the product page



The PROLIGHTS Logo, PROLIGHTS names and all other trademark in this document pertaining to PROLIGHTS services or PROLIGHTS product are trademarks OWNED or licensed by Music & Lights S.r.l., its affiliates, and subsidiaries. PROLIGHTS is a registered trademark by Music & Lights S.r.l. All right reserved. Music & Lights – Via A. Olivetti, snc - 04026 - Minturno (LT) ITALY.

INDEX

SAFETY INFORMATION	02
1 - PACKAGING	05
PACKAGE CONTENT	05
OPTIONAL ACCESSORIES	05
2 - TECHNICAL DRAWING	05
3 - INSTALLATION	06
MOUNTING	06
4 - CONNECTION TO THE MAINS SUPPLY	07
5 - START UP	07
CONNECT AND DISCONNECT POWER FROM THE PRODUCT	07
6 - PRODUCT OVERVIEW	08
7 - DMX CONNECTION	09
CONNECTION OF THE CONTROL SIGNAL: DMX LINE	09
INSTRUCTIONS FOR A RELIABLE DMX CONNECTION	09
CONNECTION DAISY CHAIN	09
CONNECTION OF THE DMX LINE	09
CONSTRUCTION OF THE DMX TERMINATION	10
DMX ADDRESSING	10
OPERATION AS A WIRELESS TRANSMITTER	10
Unlinking the transmitter	11
DMX TO WDMX (TX)	11
OPERATION AS A WIRELESS RECEIVER	11
Reset the receiver	11
WDMX TO DMX (RX)	11
8 - CONTROL PANEL	12
DISPLAY AND BUTTONS LAYOUT	12
ROTATORY KNOB LAYOUT	12
9 - MENU STRUCTURE	13
10 - RDM FUNCTIONS	16
11 - SHORTCUTS	17
12 - ERRORS	17
13 - DMX CHARTS	18
13 - ACCESSORIES INSTALLATION	21
ANTI-GLARE LOUVRE (CODE ECLEXPFL300VWLVB/W - OPTIONAL)	21
FILTER FRAME (CODE ECLEXPFL300VWFFB/W - OPTIONAL)	21
BARNDOR (CODE ECLEXPFL300VWBDB/W - OPTIONAL)	22
14 - MAINTENANCE	23
MAINTENANCE AND CLEANING THE PRODUCT	23
REPLACING THE FUSE	23
VISUAL CHECK OF PRODUCT HOUSING	23
TROUBLESHOOTING	24

SAFETY INFORMATION



WARNING!

- Please read carefully the instruction reported in this section before installing, powering, operating or servicing the product and observe the indications also for its future handling.



This unit is not for household use, only professional applications.



Connection to mains supply

- The Connection to the mains supply must be carried out by a qualified electrical installer.
- Use only AC supplies 100-240V 50-60 Hz, the fixture must be electrically connected to ground (earth).
- Select the cable cross section in according with the maximum current draw of the product and the possible number of products connected at the same power line.
- The AC mains power distribution circuit must be equipped with magnetic+residual current circuit breaker protection.
- Do not connect it to a dimmer system; doing so may damage the product.



Protection and Warning against electrical shock

- Do not remove any cover from the product, always disconnect the product from AC power before servicing.
- Ensure that the fixture is electrically connected to ground (earth). And use only a source of AC power that complies with local building and electrical codes and has both overload and ground-fault (earth-fault) protection.
- Before using the fixture, check that all power distribution equipment and cables are in perfect condition and rated for the current requirements of all connected devices.
- Isolate the fixture from power immediately if the power plug or any seal, cover, cable, or other components are damaged, defective, deformed or showing signs of overheating.
- Do not reapply power until repairs have been completed.
- Refer any service operation not described in this manual to PROLIGHTS Service team or an authorized PROLIGHTS service center.



Installation

- Make sure that all visible parts of the product are in good visible condition before its use or installation.
- Make sure the point of anchorage is stable before positioning the projector.
- When suspending the fixture above ground level, secure it against failure of primary attachments by attaching a safety cable that is approved as a safety attachment for the weight of the fixture to the attachment point on the main frame of the product. In case the safety cable, enter in action, it needs to be replaced with a new one.
- Install the product only in well ventilated places.
- For non temporary installations, ensure that the fixture is securely fastened to a load-bearing surface with suitable corrosionresistant hardware.
- For a temporary installation with clamps, ensure that the quarter-turn fastener and/or screws are turned fully, and secured with a suitable safety cable.



Minimum distance of illuminated objects

- The projector needs to be positioned so that the objects hit by the beam of light are at least 0.5 meters (1.64 ft) from the lens of the projector.

T_a45°C

Max operating ambient temperature (T_a)

- Do not operate the fixture if the ambient temperature (T_a) exceeds 45 °C (113 °F).

T_a-10°C

Minimum operating ambient temperature (T_a)

- Do not operate the fixture if the ambient temperature (T_a) is below -10 °C (14 °F).



Protection from burns and fire

- The exterior of the fixture becomes hot during use. Avoid contact by persons and materials.
- Ensure that there is free and unobstructed airflow around the fixture.
- Keep flammable materials well away from the fixture
- Do not expose the front glass to sunlight or any other strong light source from any angle. Lenses can focus the sun's rays inside the fixture, creating a potential fire hazard.
- Do not attempt to bypass thermostatic switches or fuses.



Indoor use

- This product is designed for indoor and dry environments.
- Do not use in wet location and do not expose the fixture to rain or moisture.
- Never use the fixture in places subject to vibrations or bumps.
- Make certain that no inflammable liquids, water or metal objects enter the fixture.
- Excessive dust, smoke fluid, and particle build up degrades performance, causes overheating and will damage the fixture.
- Damages caused by inadequate cleaning or maintenance are not covered by the product warranty.

T_c90°C

Temperature of the external surface

- The surface of the fixture can reach up to 90 °C (194 °F) during operation. Avoid contact with people and materials.



Maintenance

- Warning! Disconnect the fixture from AC mains power and allow to cool for at least 10 minutes before handling.
- Only technicians who are authorized by PROLIGHTS or Authorised service partners are permitted to open the fixture.
- Users may carry out external cleaning, following the warnings and instructions provided, but any service operation not described in this manual must be referred to a qualified service technician.
- Important! Excessive dust, smoke fluid, and particle build up degrades performance, causes overheating and will damage the fixture. Damages caused by inadequate cleaning or maintenance is not covered by the product warranty.



Photobiological safety

- This device emits potentially dangerous optical radiation and is identified in the category of Risk Group 2 according to EN 62471.



Do not stare at the operating light source

- Do not look directly at the LED source during operation. It can be harmful to the eyes and skin.
- During Installation, operation and maintenance, be prepared for the fixture to light and move suddenly when connected to power.
- The device should be positioned so that prolonged staring into the luminaire at a distance closer than 3 m (9.842 ft) is not expected.

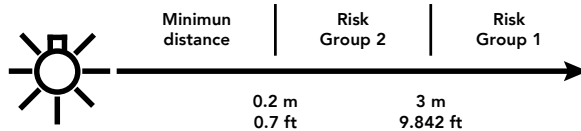

Disposal

- This product is supplied in compliance with European Directive 2012/19/EU – Waste Electrical and Electronic Equipment (WEEE). To preserve the environment please dispose/ recycle this product at the end of its life according to the local regulation.



The products to which this manual refers comply with:

- 2014/35/EU - Safety of electrical equipment supplied at low voltage (LVD).
- 2014/30/EU - Electromagnetic Compatibility (EMC).
- 2011/65/EU - Restriction of the use of certain hazardous substances (RoHS).
- 2014/53/EU - Radio Equipment Directive (RED).



The products to which this manual refers comply with:

- UL 1573 + CSA C22.2 No. 166 - Stage and Studio Luminaires and Connector Strips.
- UL 1012 + CSA C22.2 No. 107.1 - Standard for power units other than class 2.



FCC Compliance:

- This device complies with Part 15 of the FCC Rules. Operation is subject to the following two conditions:
1. This device may not cause harmful interference, and
 2. This device must accept any interference received, including interference that may cause undesired operation.



Other approvals

- The product meets the safety requirements of the certification procedures of the market in which it is placed and sold.



1 - PACKAGING

PACKAGE CONTENT

- 1x ECLEXPFL300VWBK / WH;
- 1x 1,5 meters power cable (BARE END - NEUTRIK POWERCON TRUE1);
- User manual.

OPTIONAL ACCESSORIES

- WSBBR512G6: blackBox R-512 G6 receiver 512Ch, 2.45GHz,DMX&RDM,Bluetooth,G3,G4,G4S,G5,CRMX;
- WSBBR512G5: blackBox R-512 G5 receiver 512Ch, 2.45GHz & 5.8GHz, DMX/RDM optional;
- WSBBF1G6: blackBox F-1 G6 transrec, 512ch, 2.45GHz, DMX&RDM,Bluetooth,G3,G4,G4S, G5, CRMX;
- WSBBF1G5: blackBox F-1 G5 transmitter, 2,45GHz & 5.2/5,8 GHz, DMX/RDM, 512Ch;
- TOUR53415L03BK: dmx cable HC5340. CANC5MXX XLR 5p->CANC5FXX XLR (f) 5p, L.3m;
- 958225L03: 3x2.5mm TH07 Cable, 16A 3p PwCon MXW, 16A 3p PwCon FXW, L. 3m;
- 9513FXWL03: ass. 3x2.5mm TH07 cable, 16A 3p 230V CEE plug, MENAC3FXW socket, L.3 m;
- 9533FXWL03: ass. 3x2.5mm TH07 cable, SHUKO plug, MENAC3FXW socket, L.3m;
- RSR0630A/B: steel security cable for hanging bodies, inox steel shackle, L=60 cm, silver/black;
- C6002: slim aluminium clamp, 200 kg loading, 48-51 mm tubes, M10 bolt;
- FCLEXPFL300VW: flight case for 6 pcs of ECLEXPFL300VW;
- ECLEXPFL300VWFFB / W: filter frame for ECLEXPFL300VW, black / white finishing;
- ECLEXPFL300VWLVB / W: anti-glare louvre for ECLEXPFL300VW, black / white finishing;
- ECLEXPFL300VWDB / W: barndoor for ECLEXPFL300VW, black / white finishing;
- ECLEXPFL300VWVKB / W: wireless kit for ECLEXPFL300VW, black / white finishing;
- UPBOX1U: Firmware uploader kit, USB IN, 3pin XLR DMX OUT, USB OUT.

2 - TECHNICAL DRAWING

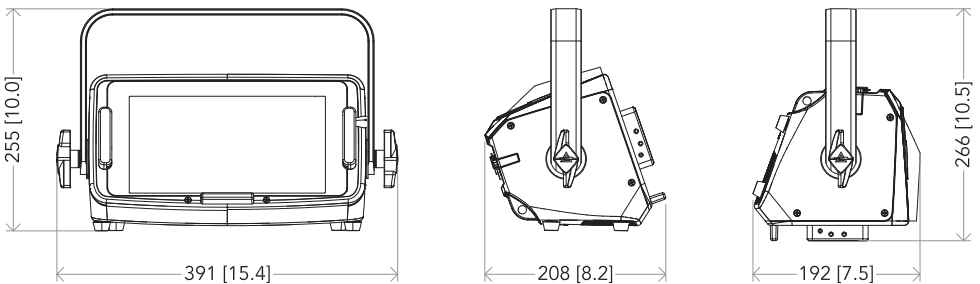

Weight: 5.1 kg / 2.31 lbs

Fig. 01

3 - INSTALLATION

MOUNTING

Check that the supporting structure can safely bear the weight of all installed fixtures, clamps, cables, auxiliary equipment, etc. and complies with locally applicable regulations.

When suspending the fixture above ground level, secure it against failure of primary attachments by attaching a safety wire that is approved as a safety attachment for the weight of the fixture to an anchor point on the product main frame.

Do not use removable parts or weak anchors for secondary attachment.

Warning! When clamping the fixture to a truss or other structure at any angle, use clamps of half-coupler type. Do not use any type of clamp that does not completely encircle the structure when fastened.

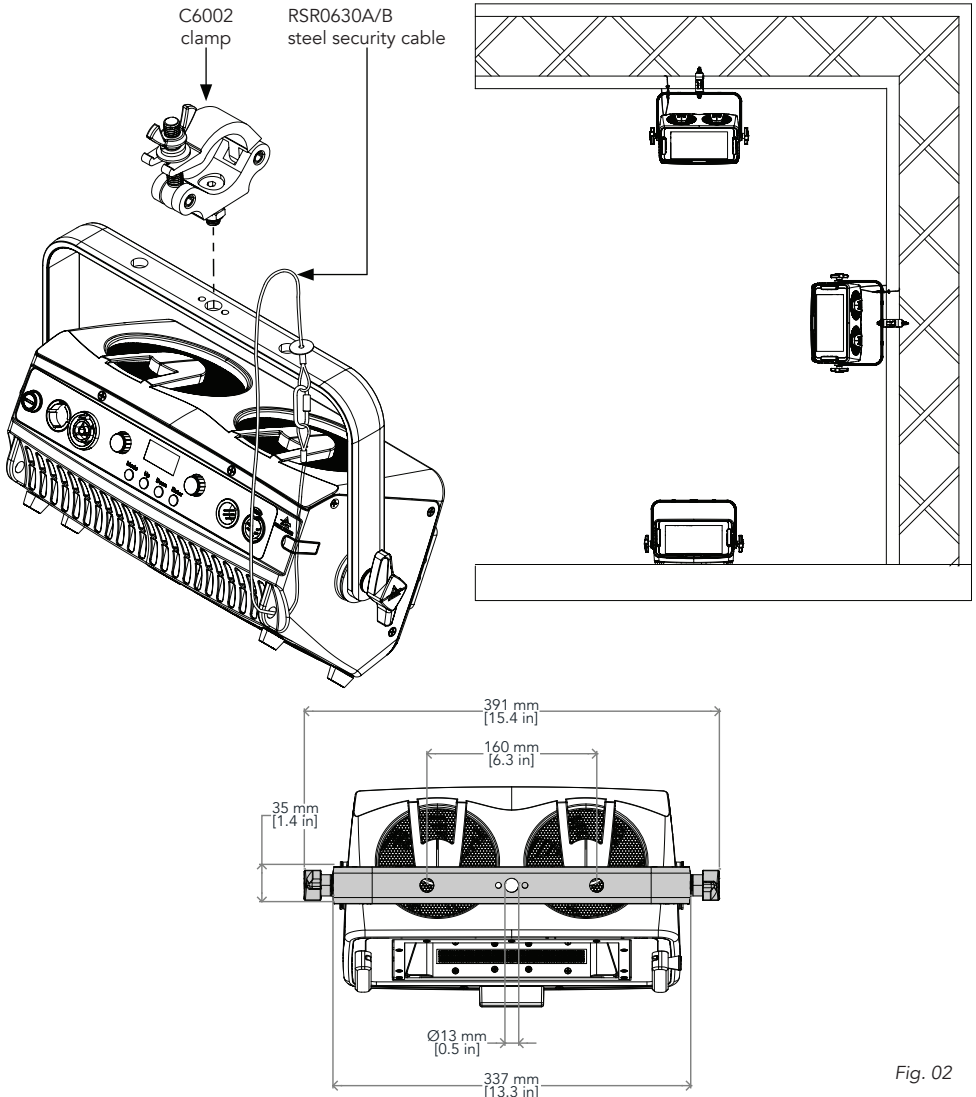

Fig. 02

4 - CONNECTION TO THE MAINS SUPPLY

WARNING: For protection from electric shock, the fixture must be earthed!

The product is equipped with auto-switching power supply that automatically adjusts to any 50-60Hz AC power source from 100-240 Volts.

If you need to install a power plug on the power cable to allow connection to power outlets, install a grounding-type (earthed) plug, following the plug manufacturer's instructions. If you have any doubts about proper installation, consult a qualified electrician.

The max power consumption is 315W.

Core (EU)	Core (US)	Connection	Plug terminal marking
Brown	Black	Live	L
Blue	White	Neutral	N
Yellow+green	Green	Earth	

5 - START UP

CONNECT AND DISCONNECT POWER FROM THE PRODUCT

To apply and disconnect power to the product:

- Check that the product is installed and secured as indicated in the Safety Informations, and that personal safety will not be put at risk when the fixture lights up.
- Connect the power connector into the Mains input socket (100-240 VAC-50/60 Hz).
- The product is then ready for its operations and can be controlled through the available input signals on board.
- To disconnect power from the product, disconnect the Mains from the socket.
- In case you wish to run the product through an external battery, then connect the product to an external battery (24-36V) into the dedicated XLR4p socket; to disconnect power, disconnect the Battery from the socket.

6 - PRODUCT OVERVIEW

1. BRACKET.
2. KNOB for bracket.
3. MAIN FUSE HOLDER: replace a burnt-out fuse by one of the same type only (T6.3 AL 250V).
4. POWER IN: for connection to the Mains 100-240V~/50-60Hz.
5. POWER OUT: power output for connection of multiple units in series.
6. ROTATORY KNOBS for product stand alone control operations.
7. USER INTERFACE with display and buttons for access to the control panel functions.
8. DMX IN (5-p XLR): 1 = GND, 2 = sign-, 3 = sign+, 4 N/C, 5 N/C.
9. DMX OUT (5-p XLR): 1 = GND, 2 = sign-, 3 = sign+, 4 N/C, 5 N/C.
10. ANTENNA of Wireless DMX Receiver internal module.

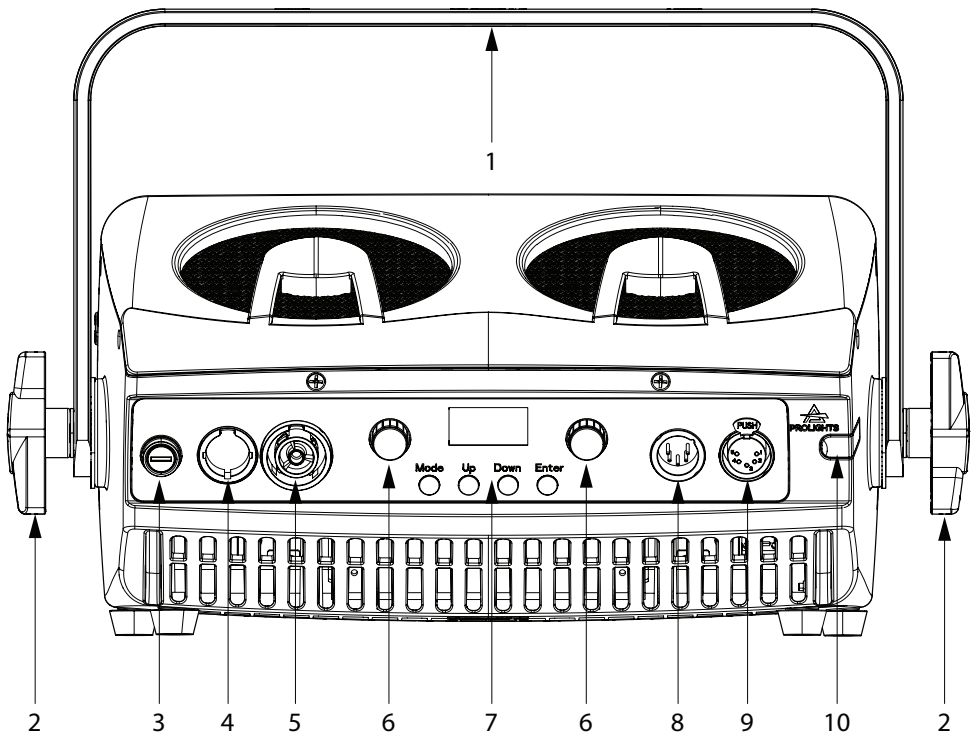

Fig. 03

7 - DMX CONNECTION

CONNECTION OF THE CONTROL SIGNAL: DMX LINE

The product has XLR sockets for DMX input and output.

The default pin-out on both socket is as the following diagram:

DMX - INPUT XLR plug



- Pin1 : GND - Shield
- Pin2 : - Signal
- Pin3 : + Signal
- Pin4 : N/C
- Pin5 : N/C

DMX - OUTPUT XLR socket

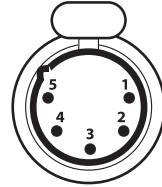

Fig. 04

INSTRUCTIONS FOR A RELIABLE DMX CONNECTION

Use shielded twisted-pair cable designed for RS-485 devices: standard microphone cable cannot transmit control data reliably over long runs. 24 AWG cable is suitable for runs up to 300 meters (1000 ft). Heavier gauge cable and/or an amplifier is recommended for longer runs.

To split the data link into branches, use splitter-amplifiers in the connection line.

Do not overload the link. Up to 32 devices may be connected on a serial link.

CONNECTION DAISY CHAIN

Connect the DMX data output from the DMX source to the product DMX input (male connector XLR) socket.

Run the data link from the product XLR output (female connector XLR) socket to the DMX input of the next fixture.

Terminate the data link by connecting a 120 Ohm signal termination. If a splitter is used, terminate each branch of the link.

Install a DMX termination plug on the last fixture on the link.

CONNECTION OF THE DMX LINE

DMX connection employs standard XLR connectors. Use shielded pair-twisted cables with 120Ω impedance and low capacity.

The following diagram shows the connection mode:

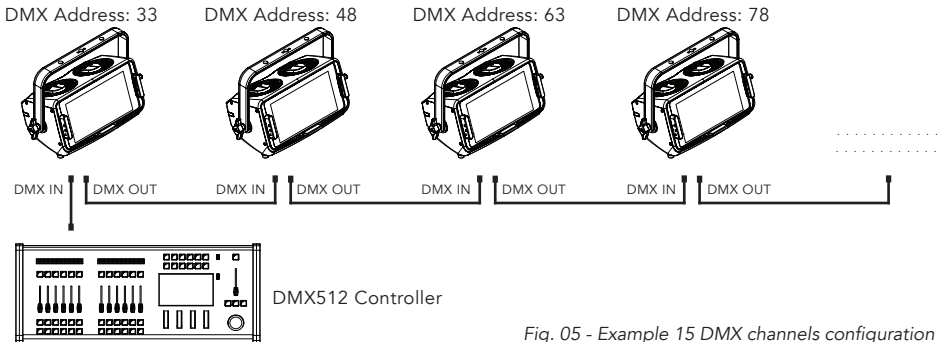

Fig. 05 - Example 15 DMX channels configuration

CONSTRUCTION OF THE DMX TERMINATION

The termination is prepared by soldering a 120Ω 1/4 W resistor between pins 2 and 3 of the male XLR connector, as shown in figure.

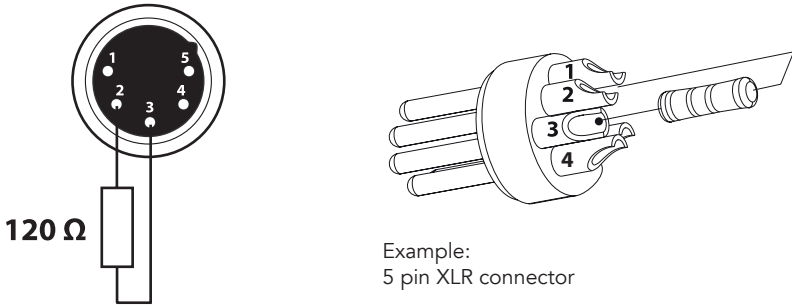

Fig. 06

DMX ADDRESSING

In order to start controlling the product via DMX, the first step is to select a DMX address, also known as the start channel, this is the first channel used to receive instructions from a DMX controller. If you wish to control the product individually, it is necessary to assign a different starting address channel to each fixture.

The number of channels occupied from the product depends on the DMX mode selected, so always verify the DMX Mode in the MENU before start addressing.

If you assign two fixtures the same address, they will be executing the same behaviour. Selecting the same address to multiple fixtures can be useful for diagnostic purposes and symmetrical control.

DMX addressing is limited to make it impossible to set the DMX address so high that you are left without enough control channels for the product.

To set the fixture's DMX address:

1. Press MENU to open the main menu.
2. Reach the addressing menu, then select the DMX ADDRESS settings.
3. Select the address from 1 to 512 using the navigation arrows/buttons and confirm by pressing ENTER.
4. Press Menu to exit and return to the Home screen.

The product DMX address, as well as other possible user settings through the MENU, can also be set when the product is disconnected from the Main through the internal battery-backup. All that is needed is to press and hold the button ENTER to momentarily enable the display and enter in the settings. Once the required operations have been executed, the display will switch off again after few seconds of being inactive.

OPERATION AS A WIRELESS TRANSMITTER

ECLEXPFL300VW can be used as wireless transmitter for transmit at different wireless receivers DMX signal. To use ECLEXPFL300VW as wireless transmitter, please follow the procedure below:

1. Push MENU button until you show CONNECT on display, then press ENTER button to confirm.
2. Use UP/DOWN buttons for select Wireless, then press ENTER to confirm.
3. Push ENTER button on WDMX ON/OFF function and enable it to ON.
4. Select WDMX mode and set it on Transmitter (please note that WDMX mode will be available only if WDMX ON/OFF is set to ON).
5. Ensure that the receiver units are not connected to any other transmitter. Please refer to "Reset the receiver" paragraph.
6. Enable TX LINK to ON to link transmitter to receivers (please note that TX LINK will be available only if WDMX mode is set to Transmitter).

- The transmitter scans for all unlinked receivers for a period of about 5 seconds.
- If the connection fails, check the position of the receiver.
- The wireless icon on the receiver display indicates the received signal strength.

Unlinking the transmitter

Follow the procedure below to unlink the transmitter from all receivers connected with the unit.

1. Push MENU button until you show CONNECT on display, then press ENTER button to confirm.
 2. Use UP/DOWN buttons for select Wireless, then press ENTER to confirm.
 3. Enable TX UNLINK to ON 8 (please note that TX UNLINK will be available only if WDMX mode is set to Transmitter).
- All connected receivers will be unlinked.

DMX TO WDMX (TX)

This function enable or disable the transmission through wireless of the DMX signal from the transmitter side to the receiver.

OPERATION AS A WIRELESS RECEIVER

ECLEXP0FL300VW can be used as wireless receiver connected to a wireless transmitter.

To use ECLEXP0FL300VW as wireless receiver, please follow the procedure below:

1. Push MENU button until you show CONNECT on display, then press ENTER button to confirm.
2. Use UP/DOWN buttons for select Wireless, then press ENTER to confirm.
3. Push ENTER button on WDMX ON/OFF function and enable it to ON.
4. Select WDMX mode and set it on Receiver (please note that WDMX mode will be available only if WDMX ON/OFF is set to ON).
5. Enable RX RESET to ON to reset the receiver (please note that RX RESET will be available only if WDMX mode is set to Receiver).
6. On the transmitter, enable TX LINK to ON to link transmitter to the receivers.
7. If the connection is successful and DMX input is available the display on the receiver unit will show the DMX address. If DMX signal is not available, the display will show "No signal" but keeps the transmitter linked.
8. If the connection fails, check the position of the receiver.
9. The wireless icon on the receiver display indicates the received signal strength.

Reset the receiver

Follow the procedure below to reset the receiver.

1. Push MENU button until you show CONNECT on display, then press ENTER button to confirm.
 2. Use UP/DOWN buttons for select Wireless, then press ENTER to confirm.
 3. Enable RX RESET to ON.
- The wireless icon on the receiver display indicates the received signal strength.

WDMX TO DMX (RX)

This function enable or disable the retransmission of the wireless DMX signal received through the DMX port on the receiver side.

8 - CONTROL PANEL

The product has a display and buttons for access to the control panel functions.

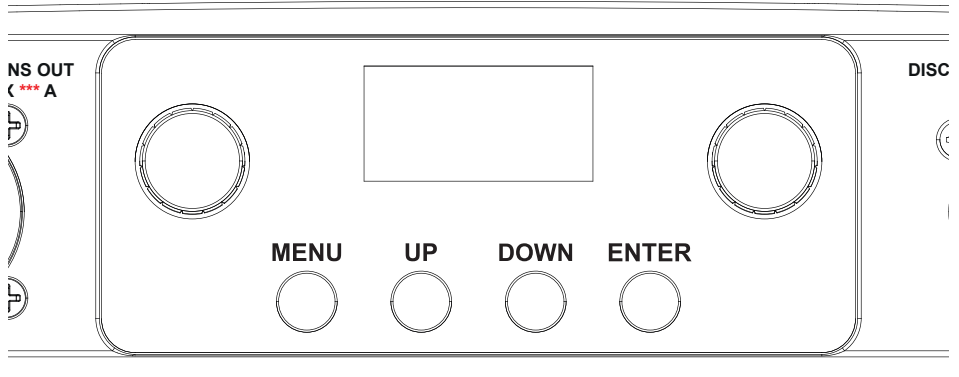

Fig. 07

DISPLAY AND BUTTONS LAYOUT

- The product has a display and buttons for access to the control panel functions.
- MENU: Used to access the menu tree or to return a previous menu window.
- UP: Browse upwards through the menu list and increases the numeric value displayed.
- DOWN: Browse downwards through the menu list and decreases the numeric value displayed.
- ENTER: Used to confirm the current menu or confirm the current function value or option within a menu.

ROTATORY KNOB LAYOUT

The product is equipped with rotatory knobs for manual control of the product, those are enabled only in Stand Alone mode and they enable access to control certain attributes according to the selected STAND ALONE mode as indicated below.

9 - MENU STRUCTURE

The following chart describes the MENU tree of the product, the terms shown in **BOLD** indicates the default settings.

MENU							
1	CONNECT	DMX ADDRESS	001-512			Choose DMX Address	
		DMX MODE	UNO	COLOR TEMPERATURE	2700K		Choose DMX Mode
					2800K		
					3000K		
					3200K		
					3500K		
					4000K		
					4500K		
					5000K		
					5600K		
	6000K						
	6500K						
	MANUAL COLOR	WARM WHITE	0-255				
		COLD WHITE	0-255				
	DUO						
	BASIC						
	STANDARD						
	EXTENDED						
	WIRELESS	WDMX ON/OFF			Enable/Disable the wireless card.		
		WDMX mode	On-Off	Allows to choose whether to set the wireless on the Transmitter or Receiver. WDMX mode is unlocked only if WDMX ON / OFF is ON.			
TX link		Transmitter Receiver	TX link unlock when the unit is set as a transmitter.				
TX unlink		On-Off	Disconnect the transmitter from all receivers. TX unlink unlocks only if WDMX mode is on transmitter.				
RX reset		On-Off	Total reset of the receiver. RX reset unlocks only if WDMX mode is receiver.				
DMX to WDMX (TX)		On-Off	Enable/Disable the transmission of the dmx from the transmitter to the receiver via wdmx.				
WDMX to DMX (RX)		On-Off	Enable/Disable the retransmission of the DMX from the receiver to the other units connected by cable to the receiver itself.				
2		SCREEN	BACKLIGHT	ON	Allows you to select the timing after that display will switch automatically off when unactive.		
	10 s						
	20 s						
	30 s						
	FLIP DISPLAY		ON	Allows you to rotate the display by 180°.			
			OFF				
	KEY LOCK	ON	Allows you lock the buttons on the control panel by a password. Press following combinations (password) in order to access to the user menu : UP, DOWN, UP, DOWN, ENTER,				
		OFF					
	TEMPERATURE UNIT	°C	To choose the desired unit of temperature measurement.				
		°F					
TRANSFER SETTINGS	WITHOUT DMX ADDRESS	To transfer the same menu settings of one fixtures to all the other in the daisy chain, including or not the dmx address.					
	WITH DMX ADDRESS						

3	ADVANCED	DIMMER CURVE	LINEAR		To choose the dimmer curve.	
			S-CURVE			
			SQUARE LAW			
			INVERSE SQUARE LAW			
		DIMMER SPEED	AUTO		To choose the dimmer speed.	
			FAST			
			MEDIUM			
			SLOW			
		WHITE CALIBRATION	OFF			
			MANUAL	CW		
				WW		
		LED FREQUENCY	600Hz		Select PWM frequency.	
			1200Hz			
			2000Hz			
			4000Hz			
			6000Hz			
		DMX FAULT	25KHz			
			BLACKOUT		To choose the behaviour of fixture in case of dmx signal lost.	
			HOLD			
			STAND ALONE			
FAN MODE	AUTO		Select the product Fan mode.			
	HIGH					
	SILENT					
	OFF					
OUTPUT CONTROL	CONSTANT		Ouput power will be reduced instantly in order to keep output constant.			
	DYNAMIC		Ouput power will be reduced in time according to fixture temperature.			
FACTORY RELOAD	ON		To reset the unit to factory default settings.			
	OFF					
4	INFORMATION	INFORMATIONS	DEVICE TIME	FIXTURE HOURS	TOTAL	To view infromation about the unit.
					PARTIAL	
			CURRENT HOURS	TOTAL		
				PARTIAL		
			SOURCE HOURS	TOTAL		
				PARTIAL		
			POWER ON CYCLE	TOTAL		
				PARTIAL		
			MAINTENANCE TIME	ELAPSED TIME		
				ALERT PERIOD		
			TEMPERATURE	NEAR SOURCE TEMP, DRIVER PCB TEMP, LED PCB TEMP,...		
			FAN SPEED			
			CHANNEL VALUE			
			ERROR MESSAGE			
			FIXTURE MODEL			
			DEVICE LABEL			
SOFTWARE VERSION						
RDM UID						

5	STAND ALONE	MASTER/ SLAVE	MASTER			Allow you to link and operating in synk multiple units without a DMX console. Choose a unit to perform as the Master. This unit must be the first unit in line; Set the successive units to be slave.	
			MASTER NO DMX				
			SLAVE				
		EFFECTS	EFFECT 1			Use the rotary knob to select the Effect.	
			EFFECT 2				
			EFFECT 3				
			EFFECT 4				
		CCT			Use the rotary knob 2 to set the CCT value.		
		WW+CW			Use the rotary knob 1 and 2 to set the WW and CW value.		
		STATIC	FIXED COLOR	WW	DIMMER <000 - 255 >	Select of the following predefined color combination and its Dimmer value. After enabled this mode, the unit will be automatically assigned as Master	
				CW			
				WW+CW			STROBE <000 - 255 >
			COLOR TEMPERATURE	2700K	DIMMER <000 - 255 >		Select a predefined White preset.
				2800K			
				3000K			
3200K							
3500K							
4000K							
4500K							
5000K							
5600K							
6000K							
6500K							
MANUAL COLOR	WW	<000 - 255 >	User generated color preset by assigning values to each primary color attribute. After enabled this mode, the unit will be automatically assigned as Master				
	CW	<000 - 255 >					
	STROBE	< 000 - 255>					

10 - RDM FUNCTIONS

The product can communicate using RDM (Remote Device Management) protocol over a DMX512 Networks.

RDM is a bi-directional communications protocol for use in DMX512 control systems, it is the open standard for DMX512 device configuration and status monitoring.

The RDM protocol allows data packets to be inserted into a DMX512 data stream without affecting existing non-RDM equipment. It allows a console or dedicated RDM controller to send commands to and receive messages from specific fixtures.

The PIDs in the following tables are supported in the product.

RDM Model ID: 0xD072

CATEGORY	PARAMETER	PID	GET	SET
Product Information	DEVICE_INFO	0x0060	x	
	PRODUCT_DETAIL_ID_LIST	0x0070	x	
	DEVICE_MODEL_DESCRIPTION	0x0080	x	
	MANUFACTURER_LABEL	0x0081	x	
	DEVICE_LABEL	0x0082	x	x
	FACTORY_DEFAULTS	0x0090	x	x
	SOFTWARE_VERSION_LABEL	0x00C0	x	
	BOOT_SOFTWARE_VERSION_ID	0x00C1	x	
	BOOT_SOFTWARE_VERSION_LABEL	0x00C2	x	
DMX512 Setup	DMX_PERSONALITY	0x00E0	x	x
	DMX_PERSONALITY_DESCRIPTION	0x00E1	x	
	DMX_START_ADDRESS	0x00F0	x	x
	SLOT_INFO	0x0120	x	
	SLOT_DESCRIPTION	0x0121	x	
	DEFAULT_SLOT_VALUE	0x0122	x	
	DMX_BLOCK_ADDRESS	0x0140	x	x
	DMX_FAIL_MODE	0x0141	x	x
Dimmer Settings	DMX_STARTUP_MODE	0x0142	x	x
	DIMMER_INFO	0x0340	x	
	MINIMUM_LEVEL	0x0341	x	x
	MAXIMUM_LEVEL	0x0342	x	x
	CURVE	0x0343	x	x
	CURVE_DESCRIPTION	0x0344	x	x
	OUTPUT_RESPONSE_TIME	0x0345	x	x
	OUTPUT_RESPONSE_TIME_DESCRIPTION	0x0346	x	
	MODULATION_FREQUENCY	0x0347	x	x
MODULATION_FREQUENCY_DESCRIPTION	0x0348	x		
Sensors	SENSOR_DEFINITION	0x0200	x	
	SENSOR_VALUE	0x0201	x	x
	RECORD_SENSORS	0x0202		x
	BURN_IN	0x0440	x	x

Parameter	PID	GET	SET	Values	Description	Default Value
DMX Fault	0x82DD	x	x	0-2	0: Blackout 1: Hold 2: Standalone Mode	0
Master/Slave	0x8211	x	x	0-2	0: Master DMX 1: Master No DMX 2: Slave	0
Standalone Mode	0x82EC	x	x	0-3	0: Static 1: CCT preset 2: Manual WW/CW 3: FX	1
Static Colors	0x82BE	x	x	0-2	0: Full WW 1: Full CW 2: Full WW+CW	1
White Presets	0x82BF	x	x	0-9	0: 2700K 1: 2800K 2: 3200K 3: 3500K 4: 4000K 5: 4500K 6: 5000K 7: 5600K 8: 6000K 9: 6500K	4
Manual WW	0x82E2	x	x	0 - 255	Set level of WW in Manual WW/ CW mode	255
Manual CW	0x82E3	x	x	0 - 255	Set level of CW in Manual WW/ CW mode	255
FX Selector		x	x	0 - 3	Choose FX 1 - 4	0
FX Speed		x	x	0 - 100	Set speed of FXs	100
Fan Mode	0x82D2	x	x	0 - 3	0: Auto 1: High 2: Silent 3: Off	0
Output Control	0x830C	x	x	0 - 1	0: Dynamic 1: Constant	0
White Calibration - WW	0x82C6	x	x	125 - 255	Calibrate level of WW	---
White Calibration - CW	0x82C7	x	x	125 - 255	Calibrate level of CW	---
Fixture Hours	0x82C5	x		0 - 65535	Show Fixture Hours	---
Power Consumption (AC 220V)	0x82DE	x			Show Power Consumption (W)	---
Maintenance Period (Alert)	0x82DF	x		0 - 300		300
Maintenance Period (Time and Reset)	0x82E0	x	x	0 - 300		---
Error Messages	0x82E0	x				---
Clean All Data	0x82C8	x	x	0 - 1	0: No 1: Yes	0

11 - SHORTCUTS

Keys	Mode	Description
MENU + ENTER then power on	Clear All	Clear all value of functions + factory default
UP + DOWN after power on	Flip Display	Directly flip display without enter inside menu

12 - ERRORS

ERROR SHOWN	POSSIBLE CAUSES
[LED TEMPERATURE SENSOR ERROR]	LED temperture sensor damaged (open or in short circuit)
[TEMPERATURE TOO HIGH]	This error message indicates that an overheating has occurred and the led has been switched OFF by the product protection system.
[MAINTENANCE TIME]	Need to be done standard maintenance and also reset of elapsed time
[DMX ACTIVE]	Transfer configuration is used with dmx signal connected

13 - DMX CHARTS

RDM Model ID: 0xD072

RDM Personality ID List

ID	DMX Mode
1	UNO
2	DUO
3	BASIC
4	STANDARD
5	EXTENDED

Channel	UNO	DUO	BASIC	STANDARD	EXTENDED
1	DIMMER	DIMMER	DIMMER	DIMMER	DIMMER
2		CCT	WARM WHITE	DIMMER FINE	DIMMER FINE
3			COLD WHITE	STROBE	STROBE
4				CCT	CCT
5				CCT FINE	CCT FINE
6					CROSSFADE
7					WARM WHITE
8					WARM WHITE FINE
9					COLD WHITE
10					COLD WHITE FINE
11					FUNCTION

UNO	DUO	BASIC	STANDARD	EXTENDED	Function	DMX Value	Default
1	1	1	1	1	DIMMER 0~100%	000 ÷ 255	000
			2	2	DIMMER FINE	000 ÷ 255	000
			3	3	STROBE Close Strobe from slow to fast Open Pulse in from slow to fast Open Pulse out from slow to fast Open Randon from slow to fast Open	000 ÷ 001 002 ÷ 062 063 ÷ 064 065 ÷ 125 126 ÷ 127 128 ÷ 188 189 ÷ 190 191 ÷ 251 252 ÷ 255	255
	2		4	4	CCT 2700K - 2800K 2800K - 2900K 2900K - 3000K 3000K - 3100K 3100K - 3200K 3200K - 3300K 3300K - 3400K 3400K - 3500K 3500K - 3600K 3600K - 3700K 3700K - 3800K 3800K - 3900K 3900K - 4000K 4000K - 4100K 4100K - 4200K 4200K - 4300K 4300K - 4400K 4400K - 4500K 4500K - 4600K 4600K - 4700K 4700K - 4800K 4800K - 4900K 4900K - 5000K 5000K - 5100K 5100K - 5200K 5200K - 5300K 5300K - 5400K 5400K - 5500K 5500K - 5600K 5600K - 5700K 5700K - 5800K 5800K - 5900K 5900K - 6000K 6000K - 6100K 6100K - 6200K 6200K - 6300K 6300K - 6400K 6400K - 6500K	0 ÷ 7 7 ÷ 13 13 ÷ 20 20 ÷ 27 27 ÷ 34 34 ÷ 40 40 ÷ 47 47 ÷ 54 54 ÷ 60 60 ÷ 67 67 ÷ 74 74 ÷ 81 81 ÷ 87 87 ÷ 94 94 ÷ 101 101 ÷ 107 107 ÷ 114 114 ÷ 121 121 ÷ 128 128 ÷ 134 134 ÷ 141 141 ÷ 148 148 ÷ 154 154 ÷ 161 161 ÷ 168 168 ÷ 174 174 ÷ 181 181 ÷ 188 188 ÷ 195 195 ÷ 201 201 ÷ 208 208 ÷ 215 215 ÷ 221 221 ÷ 228 228 ÷ 235 235 ÷ 242 242 ÷ 248 248 ÷ 255	000
			5	5	CCT FINE	000 ÷ 255	000
				6	CROSSFADE CCT to WW/CW 0~100%	000 ÷ 255	000
		2		7	WARM WHITE 0~100%	000 ÷ 255	255
				8	WARM WHITE FINE	000 ÷ 255	255
		3		9	COLD WHITE 0~100%	000 ÷ 255	255

UNO	DUO	BASIC	STANDARD	EXTENDED	Function	DMX Value	Default
				10	COLD WHITE FINE	000 ÷ 255	255
				11	FUNCTION		
					No Function	000 ÷ 001	
					Display Backlight On	002 ÷ 003	
					Display Backlight 10 s	004 ÷ 005	
					Display Backlight 20 s	006 ÷ 007	
					Display Backlight 30 s	008 ÷ 009	
					Display Flip Regular	010 ÷ 011	
					Display Flip Top Down	012 ÷ 013	
					Display Key Lock ON	014 ÷ 015	
					Display Key Lock OFF	016 ÷ 017	
					Dimmer Mode Linear	018 ÷ 019	
					Dimmer Mode S-Curve	020 ÷ 021	
					Dimmer Mode Square Law	022 ÷ 023	
					Dimmer Mode Inverse Square Law	024 ÷ 025	
					Dimmer Speed Auto	026 ÷ 027	
					Dimmer Speed Slow	028 ÷ 029	
					Dimmer Speed Medium	030 ÷ 031	
					Dimmer Speed Fast	032 ÷ 033	
					White Calibration OFF	034 ÷ 035	
					White Calibration MANUAL	036 ÷ 037	
					LED Frequency 600 Hz	038 ÷ 039	
					LED Frequency 1200 Hz	040 ÷ 041	
					LED Frequency 2000 Hz	042 ÷ 043	
					LED Frequency 4000 Hz	044 ÷ 045	
					LED Frequency 6000 Hz	046 ÷ 047	
					LED Frequency 25 kHz	048 ÷ 049	
					DMX Lost Blackout	050 ÷ 051	
					DMX Lost Hold	052 ÷ 053	
					DMX Lost Stand Alone	054 ÷ 055	
					Fan Auto	056 ÷ 057	
					Fan Silent	058 ÷ 059	
					Fan High	060 ÷ 061	
					Fan OFF	062 ÷ 063	
					Stand Alone Master Dmx	064 ÷ 065	
					Stand Alone Master No Dmx	066 ÷ 067	
					Stand Alone Slave	068 ÷ 069	
					Stand Alone Effect	070 ÷ 071	
					Stand Alone CCT	072 ÷ 073	
					Stand Alone WW+CW	074 ÷ 075	
					Stand Alone White Presets	076 ÷ 077	
					Stand Alone Fixed Color	078 ÷ 079	
					Stand Alone Color Temperature	080 ÷ 081	
					Stand Alone Manual Color	082 ÷ 083	
					Menu Stand Alone	084 ÷ 085	
					Output Control Constant	086 ÷ 087	
					Output Control Dynamic	088 ÷ 089	
					RESERVED	090 ÷ 253	
					FACTORY DEFAULT OF ALL CONTROLLED FUNCTION	254 ÷ 255	

13 - ACCESSORIES INSTALLATION

ANTI-GLARE LOUVRE (CODE ECLEXPFL300VWLVB/W - OPTIONAL)
FILTER FRAME (CODE ECLEXPFL300VWFFB/W - OPTIONAL)

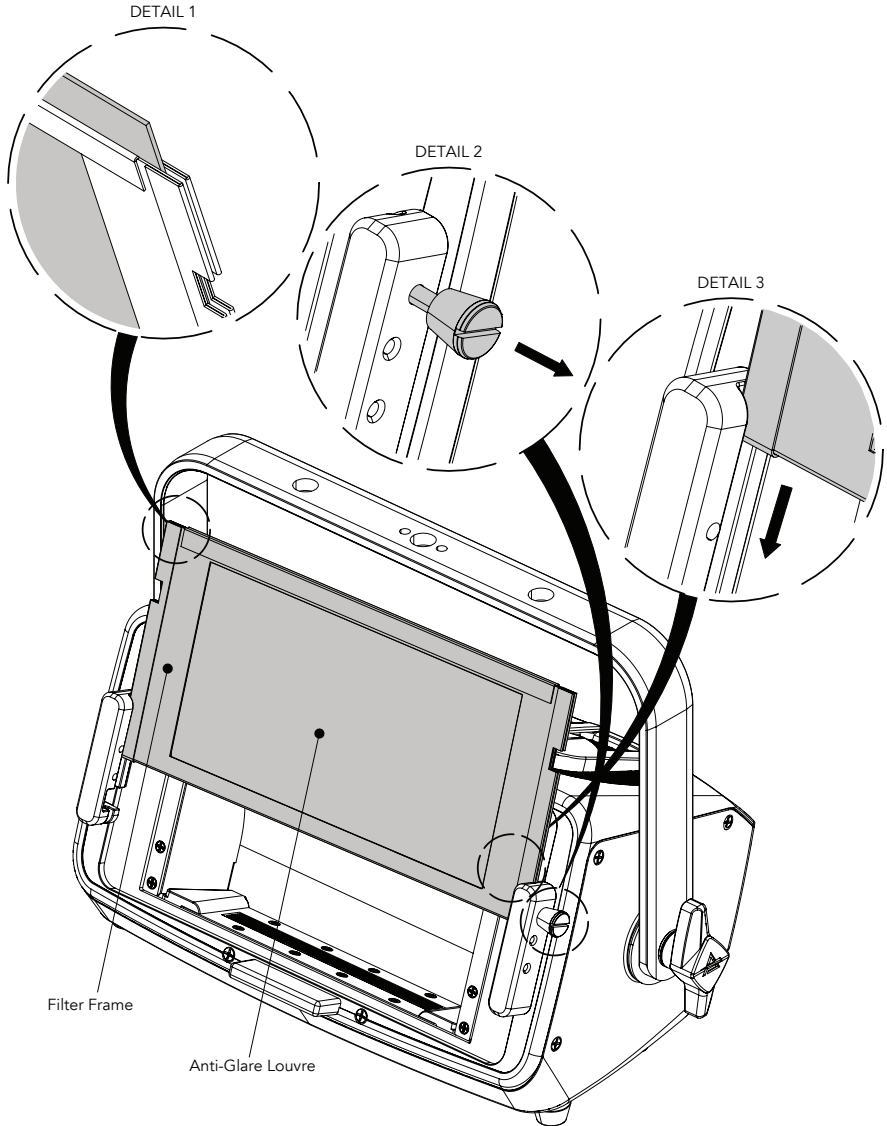

Insert the anti-glare louvre into the slot (DETAIL 1). Pull the knob out (DETAIL 2) and insert the accessory filter frame from the top into the guide on the hardware of the unit (DETAIL 3). Then release the knob (DETAIL 3).

NOTE: To remove the accessory, reverse the procedure.

Fig. 08

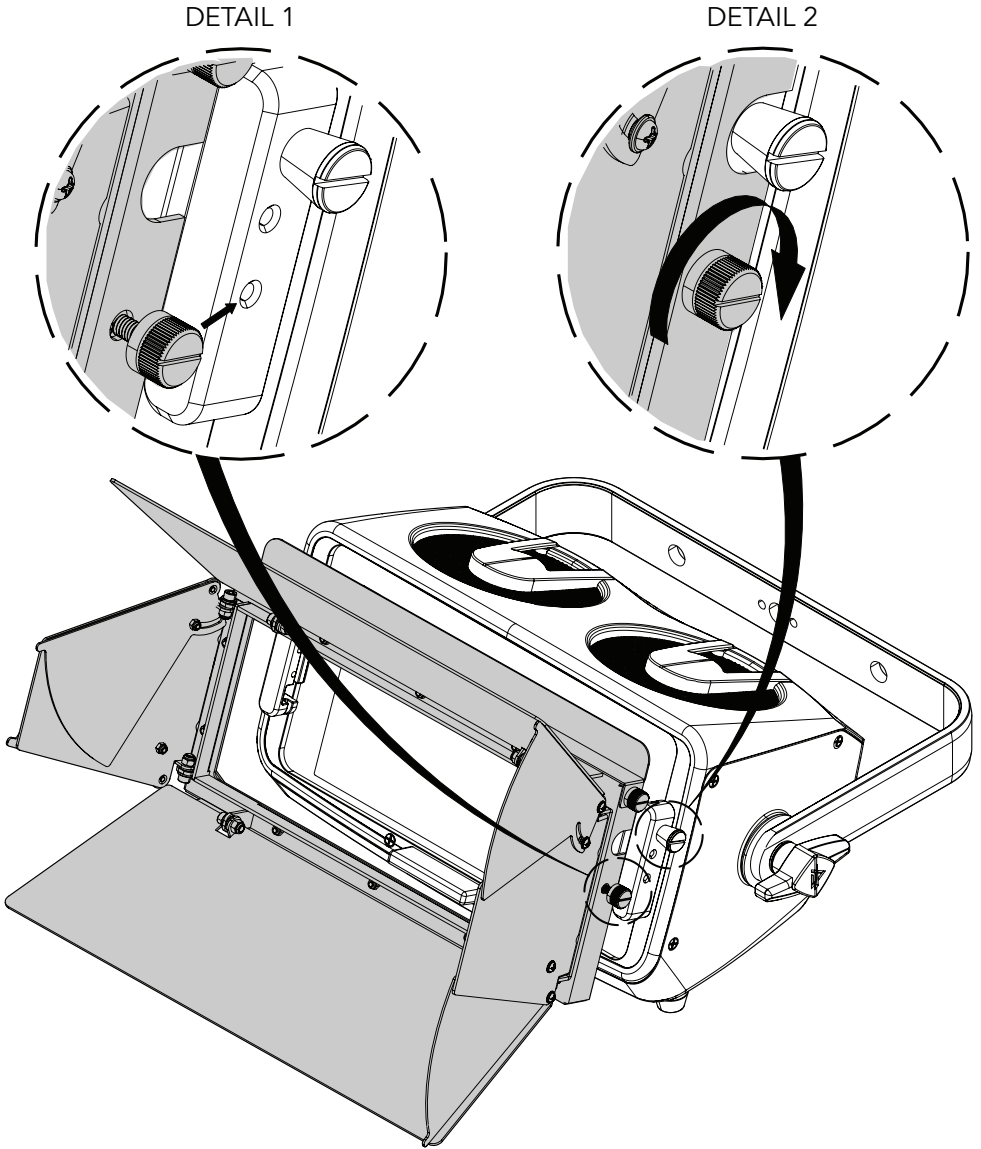

Unscrew the knob of the barndoor accessory (DETAIL 1). Then mount the barndoor by screwing the knob with the hole on the unit hardware (DETAIL 2).

NOTE: To remove the accessory, reverse the procedure.

Fig. 09

14 - MAINTENANCE

MAINTENANCE AND CLEANING THE PRODUCT

WARNING: Disconnect from the mains before starting any maintenance work

It is recommended to clean the front at regular intervals, from impurities caused by dust, smoke, or other particles to ensure that the light is radiated at maximum brightness.

- For cleaning, disconnect the main plug from the socket. Use a soft, clean cloth moistened with a mild detergent. Then carefully wipe the part dry. For cleaning other housing parts use only a soft, clean cloth. Never use a liquid, it might penetrate the unit and cause damage to it.
- The user must clean the product periodically to maintain optimum performance and cooling. The user may also upload firmware (product software) to the fixture via the DMX signal input port or USB port using firmware and instructions from PROLIGHTS.
- The frequency of such maintenance operations is to be performed according to various factors, such as the amount of the use and the condition of the installation environment (air humidity, presence of dust, salinity, etc.). It is recommended that the product is subject to annual service by a qualified technician for special maintenance involving at least the following procedures:
- General cleaning of internal parts.
- Restoring lubrication of all parts subject to friction, using lubricants specifically supplied by PROLIGHTS.
- General visual check of the internal components, cabling, mechanical parts, etc.
- Electrical, photometric and functional checks; eventual repairs.
- Cleaning the lenses. Only use neutral soap and water to clean the lenses, then dry it carefully with a soft, non-abrasive cloth.

WARNING: the use of alcohol or any other detergent could damage the lenses.

- All other service operations on the product must be carried out by PROLIGHTS, its approved service agents or trained and qualified personnel.
- It is PROLIGHTS policy to apply the strictest possible calibration procedures and use the best quality materials available to ensure optimum performance and the longest possible component lifetimes. However, optical components are subject to wear and tear over the life of the product, resulting in gradual changes in colours over many thousands of hours of use. The extent of wear and tear depends heavily on operating conditions and environment, so it is impossible to specify precisely whether and to what extent performance will be affected. However, you may eventually need to replace optical components if their characteristics are affected by wear and tear after an extended period of use and if you require fixtures to perform within very precise optical and colour parameters.
- Do not apply filters, lenses or other materials on lenses or other optical components. Use only accessories approved by PROLIGHTS.

REPLACING THE FUSE

WARNING: Before replacing the fuse, unplug the product from the mains.

- Remove the old fuse from the housing with a suitable screwdriver (anticlockwise) and replace it with one of the same type and of the same classification (T6.3 AL 250V).

VISUAL CHECK OF PRODUCT HOUSING

- The parts of the product cover/housing should be checked for eventual damages and breaking start at least every two months. In addition, especially the parts of the front lens holder have to be checked mechanically (by means of movement by the part) if it is firmly fastened to the fixture. If hint of a crack is found on some plastic part, do not use the product until the damaged part will be replaced.
- Cracks or another damages of the cover/housing parts can be caused by the product transportation or manipulation and also ageing process may influence materials.
- This checking is necessary for both fixed installations and preparing product for renting. Any free moving parts inside of the product, cracked cover/housing or any part of front lens not sitting properly in place need to be immediately replaced.

TROUBLESHOOTING

Problems	Possible causes	Checks and remedies
Product doesn't power ON	<ul style="list-style-type: none"> No power to the product. 	<ul style="list-style-type: none"> Check that power is switched ON and cables are plugged in.
	<ul style="list-style-type: none"> Fuse blown or internal fault. 	<ul style="list-style-type: none"> Check if the Fuse is intact and eventually replace it if necessary. Contact the PROLIGHTS Service or authorized service partner. Do not remove parts and/or covers, or carry out any repairs or service that are not described in this Safety and User Manual unless you have both authorization from PROLIGHTS and the service documentation.
Product reset correctly but does not respond correctly to the controller.	<ul style="list-style-type: none"> Bad signal connection. 	<ul style="list-style-type: none"> Inspect connections and cables. Fix eventual bad connections. Repair or replace damaged cables.
	<ul style="list-style-type: none"> Signal connection not terminated. 	<ul style="list-style-type: none"> Insert DMX termination plug in signal output socket of the last product on the signal line.
	<ul style="list-style-type: none"> Incorrect addressing of the product. 	<ul style="list-style-type: none"> Check the product address and control settings.
	<ul style="list-style-type: none"> One of the product is defective and is corrupting the signal transmission on the signal line. 	<ul style="list-style-type: none"> Unplug the XLR in and out connectors and connect them directly together to bypass one product at a time until normal operation is regained. Once found the error, have that fixture serviced by a qualified technician.
Timeout error after fixture reset.	<ul style="list-style-type: none"> One or more hardware components requires mechanical adjustments. 	<ul style="list-style-type: none"> Check product stored error messages for more information. Contact PROLIGHTS Service or an authorized service partner.
Mechanical effect loses position	<ul style="list-style-type: none"> Mechanical hardware require cleaning, adjustment or lubrication. 	<ul style="list-style-type: none"> Check product stored error messages for more information. Contact PROLIGHTS Service or an authorized service partner.
Light output turn OFF Intermittently	<ul style="list-style-type: none"> Fixture is too hot. 	<ul style="list-style-type: none"> Check product stored error messages. Allow product to cool. Clean the product and airflow filters. Reduce ambient temperature.
	<ul style="list-style-type: none"> Hardware failure (temperature sensor, fans, Light source...). 	<ul style="list-style-type: none"> Check product stored error messages for more information. Contact PROLIGHTS Service or an authorized service partner.
General low light intensity	<ul style="list-style-type: none"> Dirty lens assembly 	<ul style="list-style-type: none"> Clean the fixture regularly.
	<ul style="list-style-type: none"> Dirty or damaged filters 	<ul style="list-style-type: none"> Install lens assembly properly.

Contact an authorized service center in case of technical problems or not reported in the table can not be resolved by the procedure given in the table.



PROLIGHTS is a trademark of
MUSIC & LIGHTS S.r.l.
musiclights.it

Via A.Olivetti snc
04026 - Minturno (LT) ITALY
Tel: +39 0771 72190

prolights.it
support@prolights.it