



Photometric Test Report



EclipseFresnel2K DY

Cold White LED Fresnel Luminaire

CONTENTS

Table of contents	2
Testing process	2
Color preset Full on	
Beam angle 45°	3
Beam angle 30°	8
Beam angle 15°	13

TESTING PROCESS

Prolights has its own optical testing laboratory in order to provide accurate photometric reports for its lighting products. The testing laboratory contains certain variety of precise lighting measurement systems that ensure an optimal reading of all the characteristic parameters of the lighting devices. All measurements are made at a controlled room temperature of 20°C without any external light sources. This photometric report is obtained through the data measured by a high precision measurement system and analyzed by a dedicate software.

Prolights measurement instrument

Prolights measurement instrument is a complete measurement system for any light source. It's equipped with two-axis goniometer, that enables to measure the full 3D distribution field of the light source. This instrument measures the light intensity, the beam angle and the most significative colors parameters, like color temperature, spectral distribution, CRI, CQS, TM-30 with a very high accuracy rate.

Please Note: All measurements are made with light source at operating temperature. Before starting the measurement, the instrument analyzes the process of the light source during the heating phase. The measuring process of all the parameters begins only when the light emission is stable, that is with a variation of less than 0.5% in a 15 minutes time frame.

Prolights measurement software

The software provides user friendly interface for the operator who does the measurements, and it also analyzes and processes all the collected data by the instrument. With this software it is possible to see the measured data in real-time and it is possible to examine all the measured data and graphics afterwards as well. All information is collected in a specific Prolights template, and the software creates also IES and LDT files, which are widely used to transfer the photometric data, and to develop lighting system.

Additionally, the fixtures are rechecked using various hand-held instruments like Sekonic C-700 and Gossen Mavospec Base, this is done to ensure, that the data in the photometric report are as accurate as possible.



Total lumen output:

32428 lm

Total candela output:

57651 cd

Light quality:

CRI: 91,4

Color temperature:

5525 K

PRODUCT NAME:

EclipseFresnel2kDY

MEASUREMENT CONDITIONS:

Beam angle:

45°

Target:

5600K

Operator:

Paolo Carvone

Date and time:

30/01/2020 13:23:35

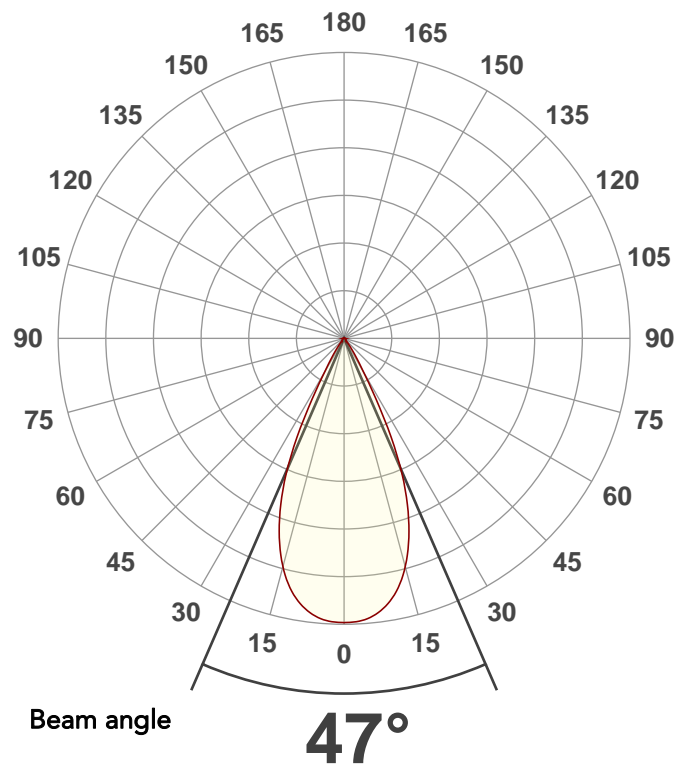

Spectra

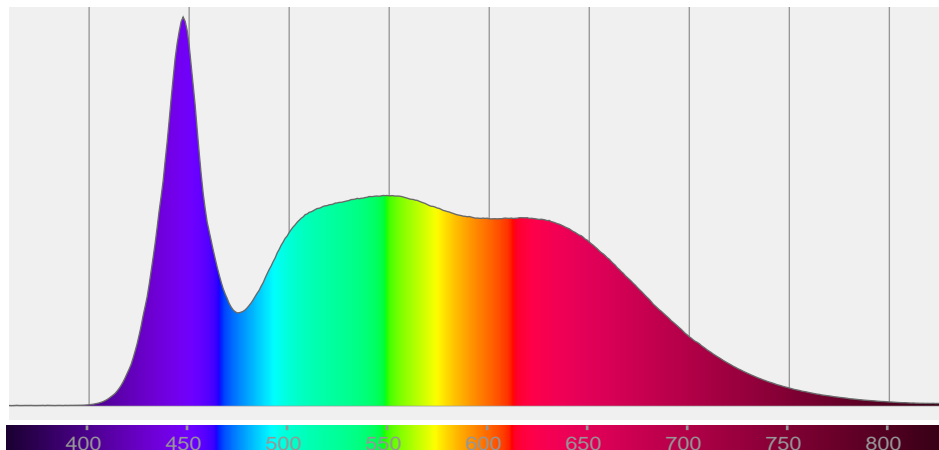

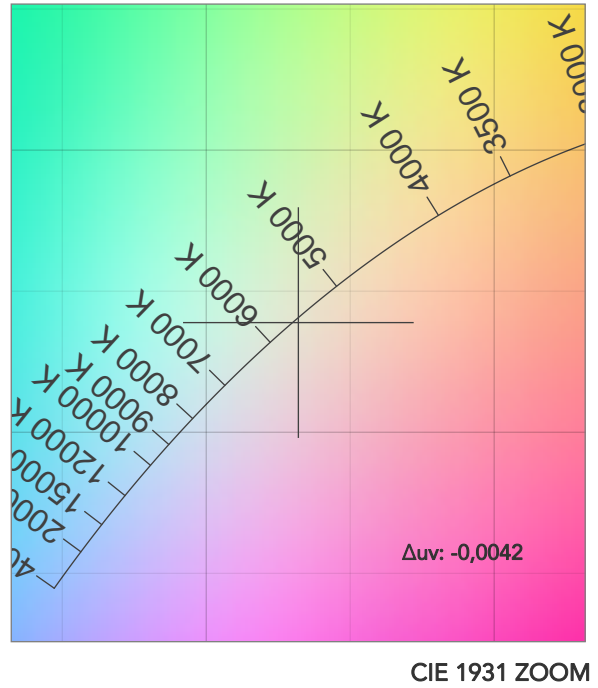
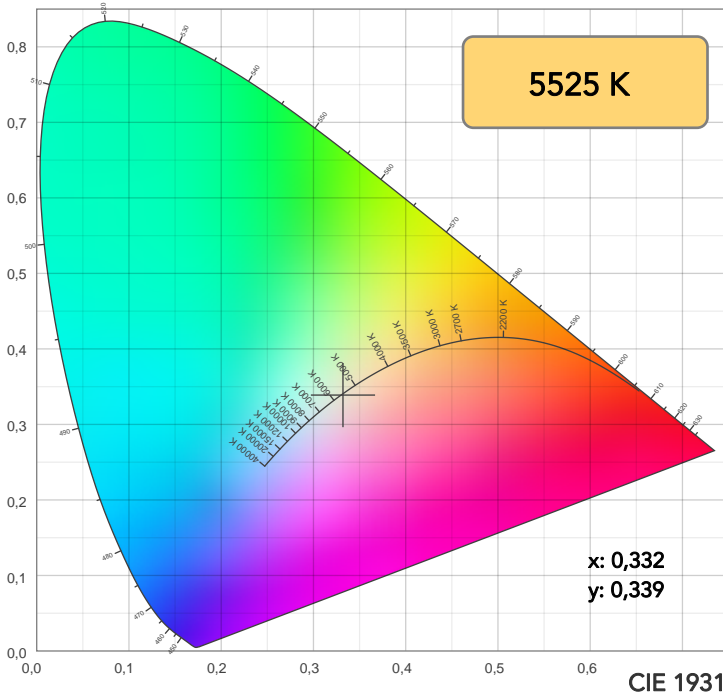

TM30: 88,2

CRI: 91,4 (R1-R8)

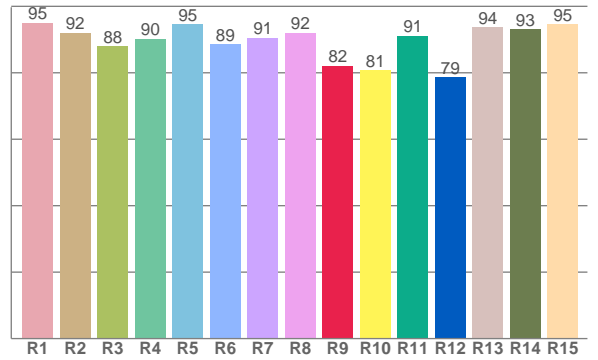
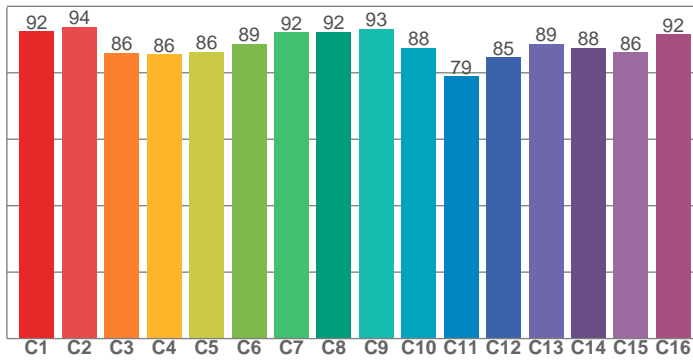

CRI R values, only R1-R8 are used to calculate final CRI value

R1	R2	R3	R4	R5	R6	R7	R8	R9	R10	R11	R12	R13	R14	R15
95,1	92,0	88,0	90,2	94,5	88,6	90,6	92,1	82,1	80,8	91,1	78,6	93,7	93,1	94,7

TM30 C values, 16 binned values out of total of 99 C values

C1	C2	C3	C4	C5	C6	C7	C8	C9	C10	C11	C12	C13	C14	C15	C16
92,5	93,8	86,0	85,6	86,3	88,6	92,2	92,3	93,3	87,6	78,9	84,6	88,7	87,6	86,2	91,5

CQS Q values

Q1	Q2	Q3	Q4	Q5	Q6	Q7	Q8	Q9	Q10	Q11	Q12	Q13	Q14	Q15
94,9	94,8	81,8	85,5	91,8	90,5	91,8	97,7	93,2	88,1	88,5	90,2	92,7	93,2	93,8

CQS: 90,4

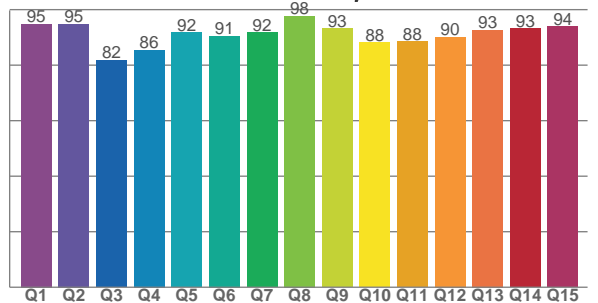

COLOR PARAMETERS

Color temperature	Color rendering index	Red component	Color fidelity	Color gamut	Color quality scale	Television lighting index	Color coordinate cie 1931	Color coordinate cie 1931	Color deviation from black body
CCT	CRI	CRI R9	TM30 Rf	TM30 Rg	CQS	TLCI	x	y	Δuv
5525 K	91,4	82,1	88,2	103,8	90,4	93	0,332	0,339	-0,0042

TM30 DETAILS

Rf 88,2
Fidelity index Rf

Rg 103,8
Gammut index

Hue Bin	R _f	Graphic shifts (%)	
		Chroma	Hue
1	92	-2%	-2%
2	94	-3%	2%
3	86	-1%	7%
4	86	2%	8%
5	86	5%	6%
6	89	7%	1%
7	92	4%	-3%
8	92	-1%	-4%
9	93	-4%	-1%
10	88	-4%	5%
11	79	-1%	12%
12	85	2%	9%
13	89	7%	6%
14	88	7%	1%
15	86	10%	-7%
16	92	2%	-4%

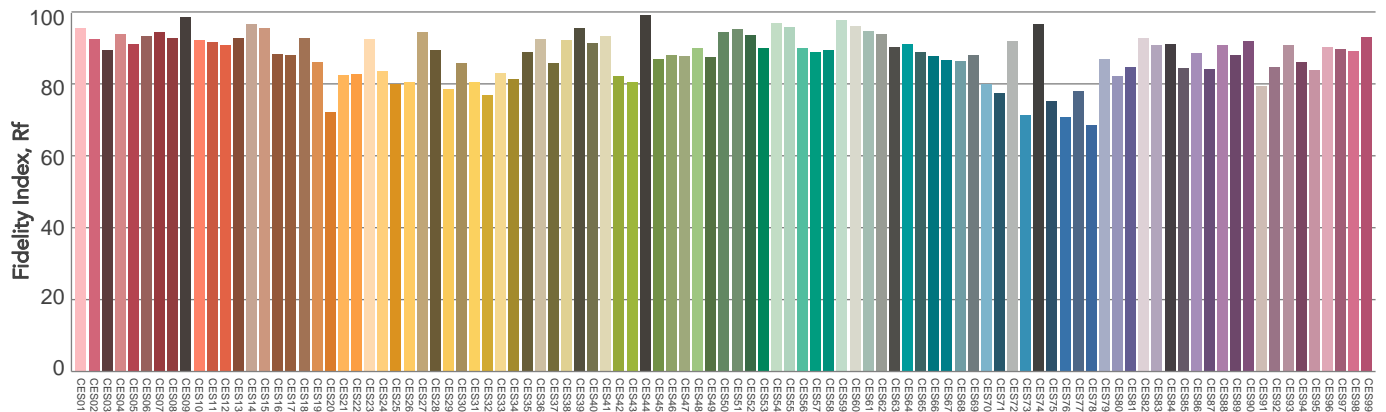
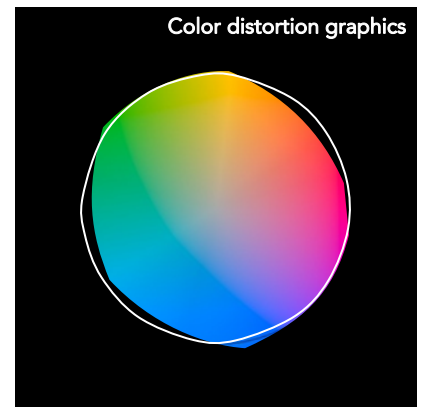
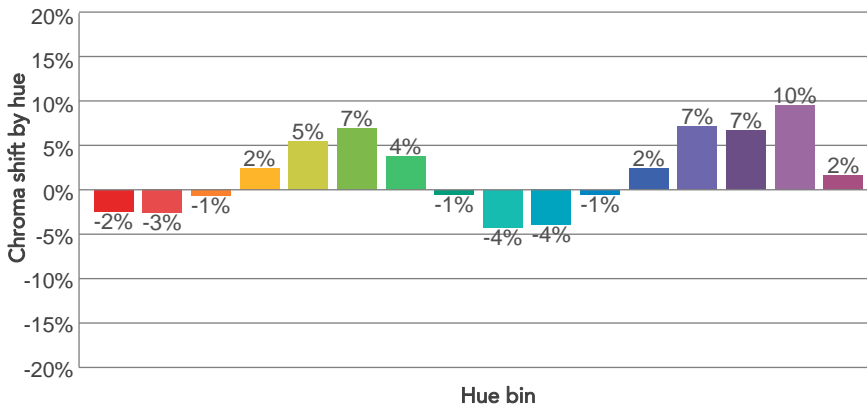
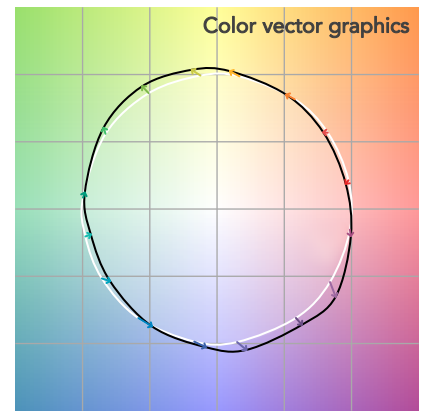
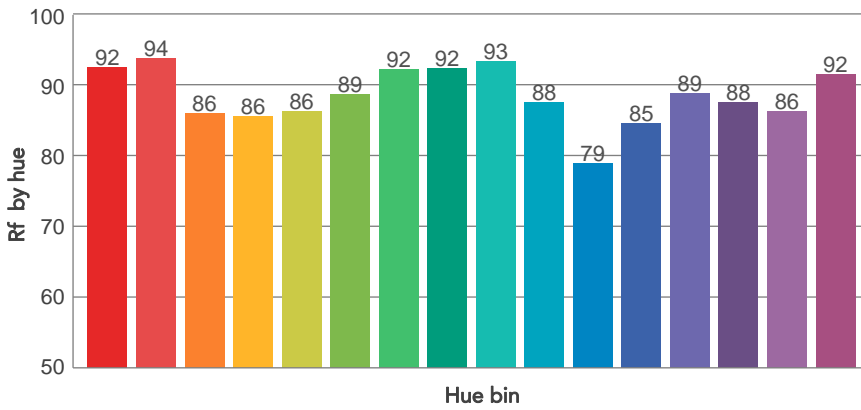
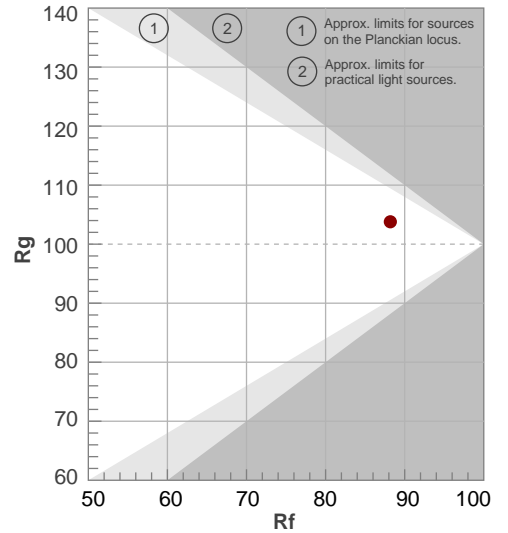

BEAM DETAILS



Beam angle 50%	Field angle 10%	Cutoff angle 2,5%	Intensity ratio in 120° cone	Intensity ratio in 90° cone
47°	63,3°	76,3°	97,8%	96,1%

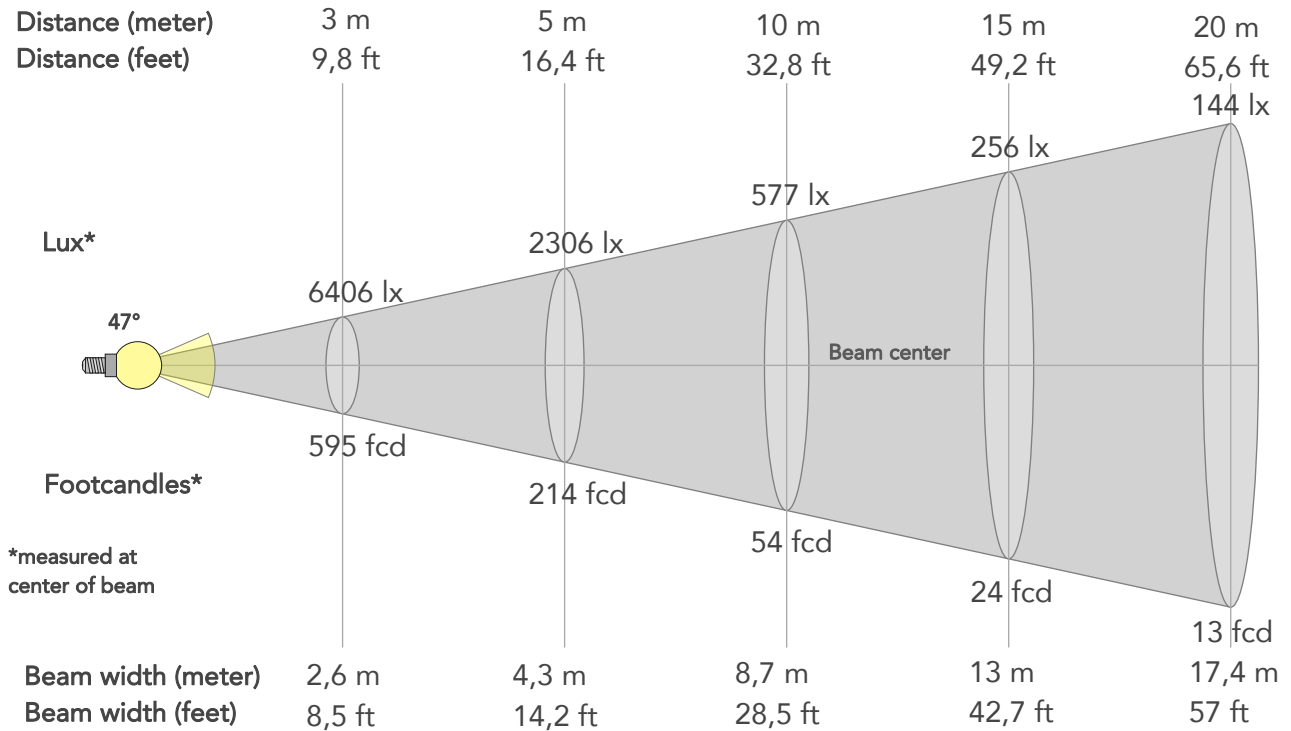

BEAM INTENSITIES AND WIDTHS

Distance	1m	2m	3m	4m	5m	7,5m	10m	15m	20m	25m	30m	40m	50m
Distance	3,3ft	6,6ft	9,8ft	13,1ft	16,4ft	24,6ft	32,8ft	49,2ft	65,6ft	82ft	98,4ft	131,2ft	164ft
Lux	57651lx	14413lx	6406lx	3603lx	2306lx	1025lx	577lx	256lx	144lx	92lx	64lx	36lx	23lx
Footcand.	5356fcd	1339fcd	595fcd	335fcd	214fcd	95fcd	54fcd	24fcd	13fcd	9fcd	6fcd	3fcd	2fcd
Beam wid.	0,9m	1,7m	2,6m	3,5m	4,3m	6,5m	8,7m	13m	17,4m	21,7m	26,1m	34,7m	43,4m
Beam wid.	2,9ft	5,7ft	8,5ft	11,4ft	14,2ft	21,4ft	28,5ft	42,7ft	57ft	71,2ft	85,5ft	114ft	142,5ft

LINEAR DISTRIBUTION DIAGRAM

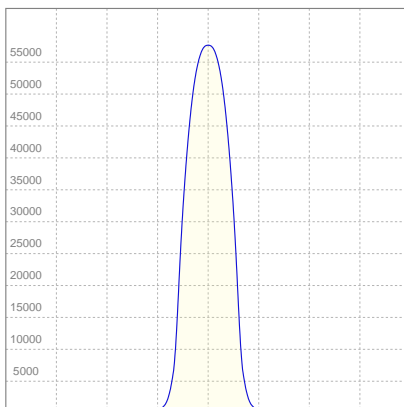

ELECTRICAL SPECIFICATIONS

Input voltage	Input current	Input power	Effeciency
224V	2,10A	457W	71lm/W

ISO CANDELA DIAGRAM

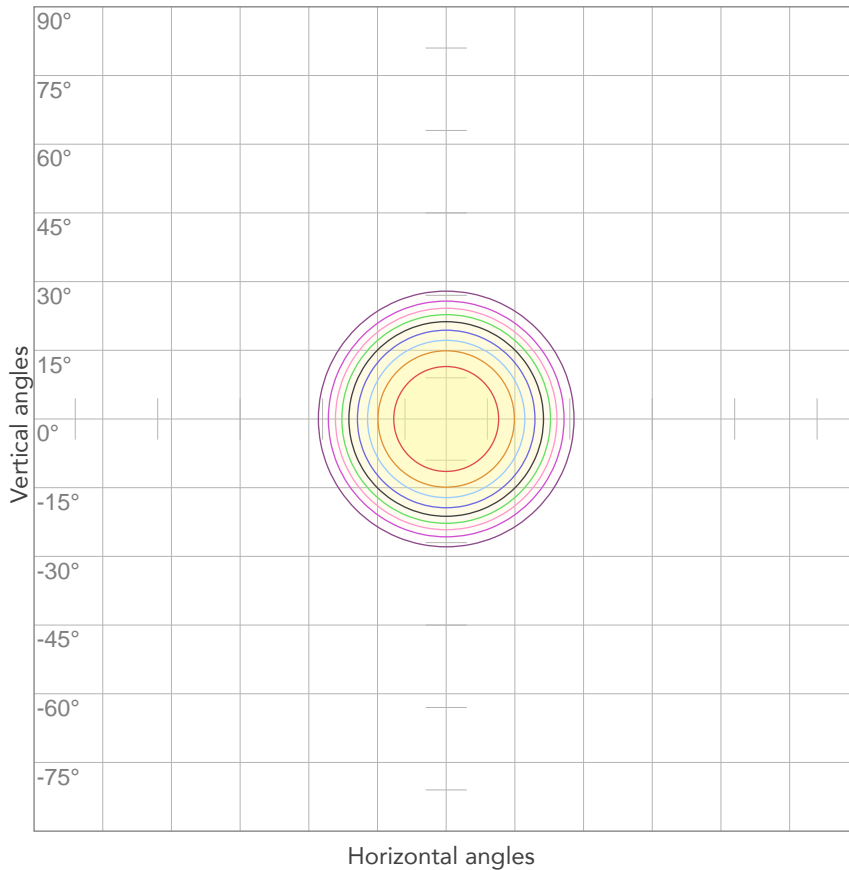

10%	5765 cd
20%	11530 cd
30%	17295 cd
40%	23060 cd
50%	28825 cd
60%	34591 cd
70%	40356 cd
80%	46121 cd

Conditions:

Number of c-planes: 2

Candela at center: 57651 cd

ISO LUX DIAGRAM

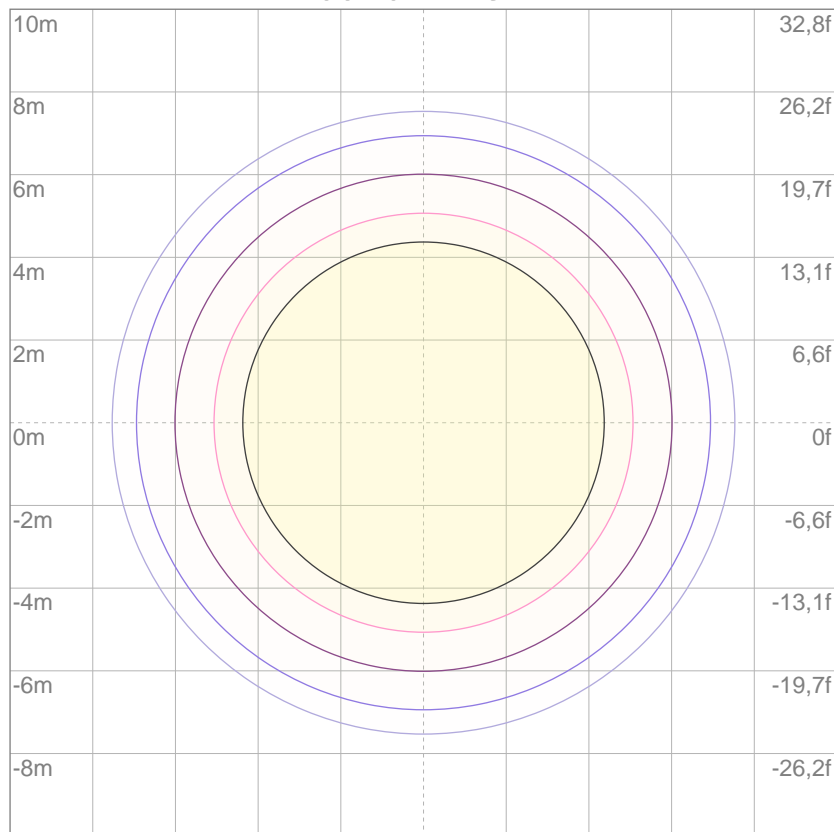

3%	17,3 lx
5%	28,8 lx
10%	57,7 lx
30%	173 lx
50%	288 lx

Conditions:

Number of c-planes: 2

Lux at center: 577 lx

Lux distribution on a surface when lamp is mounted at 10 meters from the surface.

Mounting height: 10 meters (33 feet)



Total lumen output:

32350 lm

Total candela output:

139644 cd

Light quality:

CRI: 91,4

Color temperature:

5563 K

PRODUCT NAME:

EclipseFresnel2kDY

MEASUREMENT CONDITIONS:

Beam angle:

30°

Target:

5600K

Operator:

Paolo Carvone

Date and time:

30/01/2020 13:20:37

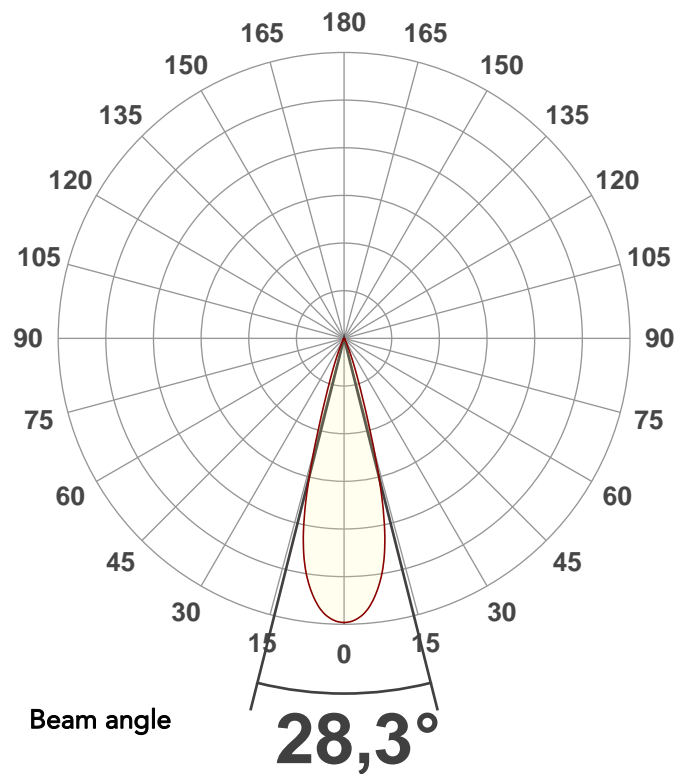

Spectra

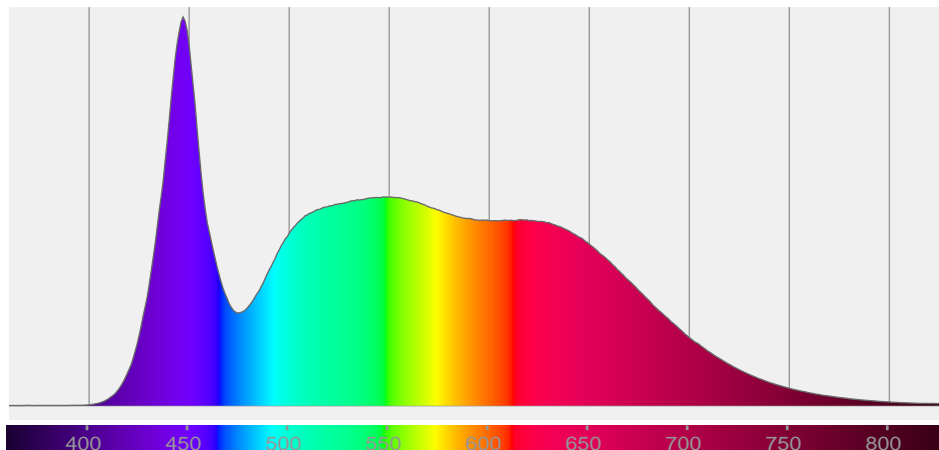

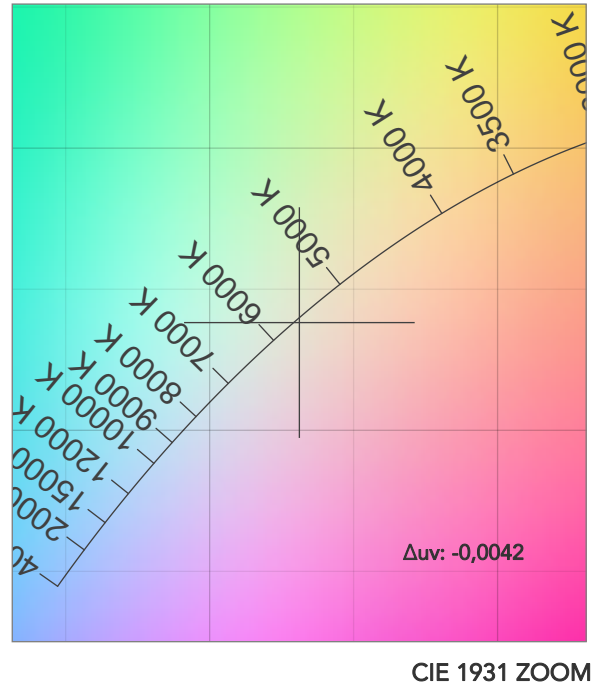
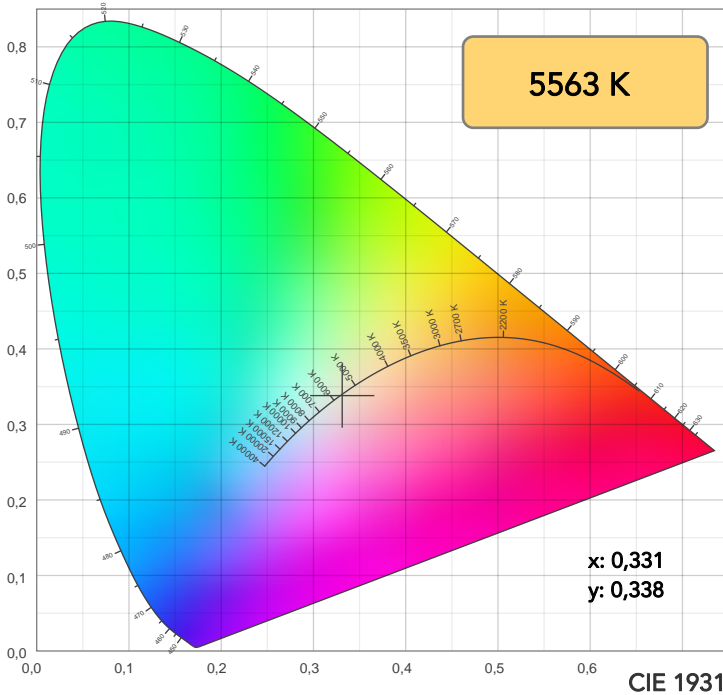

TM30: 88,2

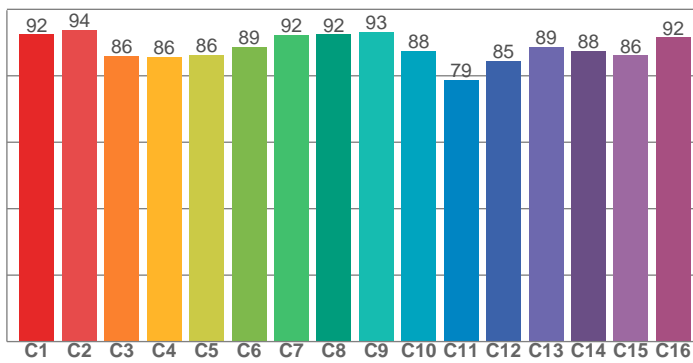

CRI: 91,4 (R1-R8)

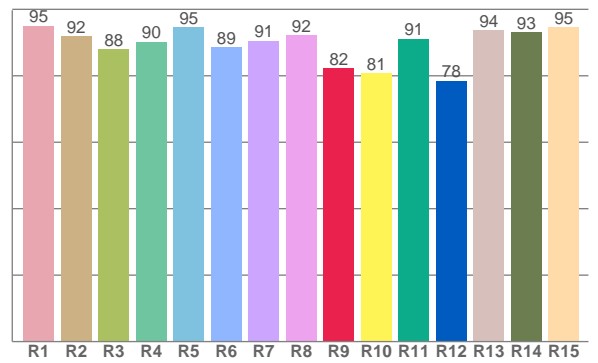

CRI R values, only R1-R8 are used to calculate final CRI value

R1	R2	R3	R4	R5	R6	R7	R8	R9	R10	R11	R12	R13	R14	R15
95,1	92,0	87,9	90,2	94,5	88,5	90,6	92,1	82,2	80,7	91,1	78,5	93,7	93,1	94,7

TM30 C values, 16 binned values out of total of 99 C values

C1	C2	C3	C4	C5	C6	C7	C8	C9	C10	C11	C12	C13	C14	C15	C16
92,5	93,8	86,0	85,6	86,3	88,7	92,3	92,4	93,3	87,5	78,8	84,6	88,7	87,6	86,1	91,5

CQS Q values

Q1	Q2	Q3	Q4	Q5	Q6	Q7	Q8	Q9	Q10	Q11	Q12	Q13	Q14	Q15
95,0	94,8	81,7	85,4	91,8	90,6	91,8	97,7	93,2	88,1	88,4	90,2	92,7	93,2	93,9

CQS: 90,4

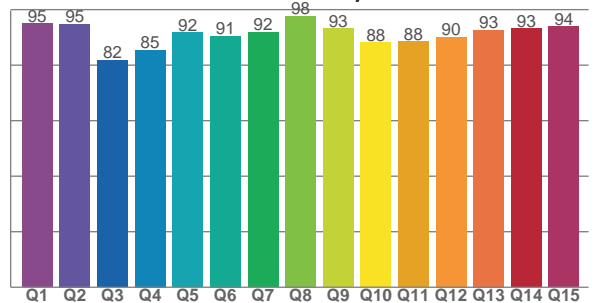

COLOR PARAMETERS

Color temperature	Color rendering index	Red component	Color fidelity	Color gamut	Color quality scale	Television lighting index	Color coordinate cie 1931	Color coordinate cie 1931	Color deviation from black body
CCT	CRI	CRI R9	TM30 Rf	TM30 Rg	CQS	TLCI	x	y	Δuv
5563 K	91,4	82,2	88,2	103,8	90,4	93	0,331	0,338	-0,0042

TM30 DETAILS

Rf 88,2
Fidelity index Rf

Rg 103,8
Gammut index

Hue Bin	R _f	Graphic shifts (%)	
		Chroma	Hue
1	92	-2%	-2%
2	94	-3%	2%
3	86	-1%	7%
4	86	2%	8%
5	86	5%	6%
6	89	7%	1%
7	92	4%	-3%
8	92	-1%	-4%
9	93	-4%	-1%
10	88	-4%	5%
11	79	-1%	12%
12	85	2%	9%
13	89	7%	6%
14	88	7%	1%
15	86	10%	-7%
16	92	2%	-4%

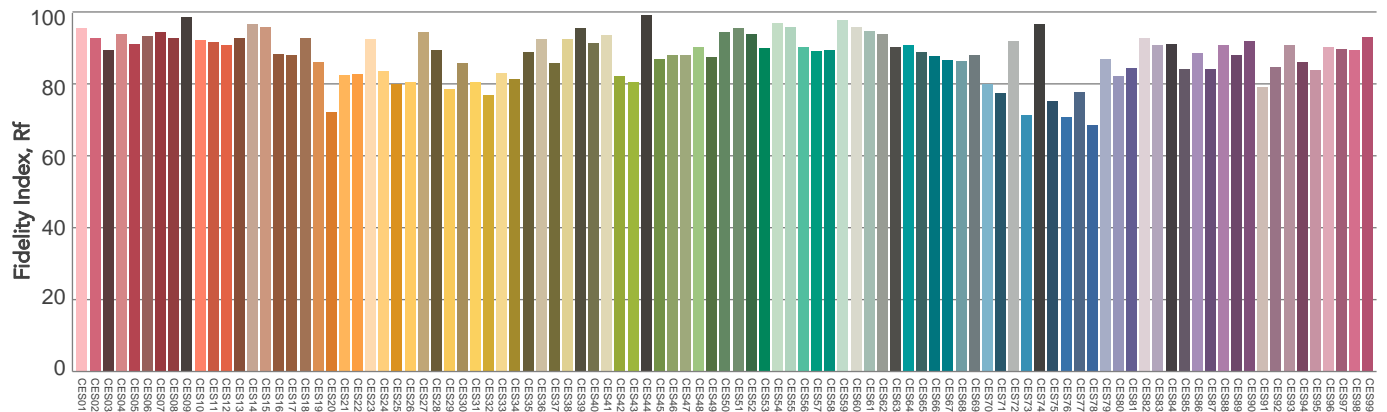
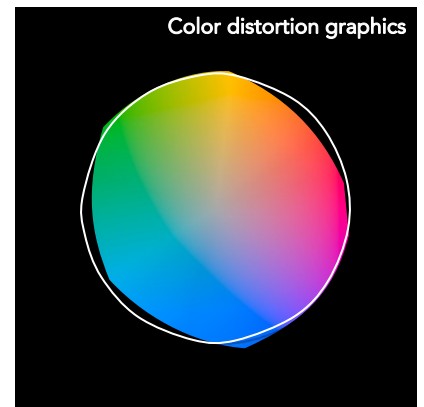
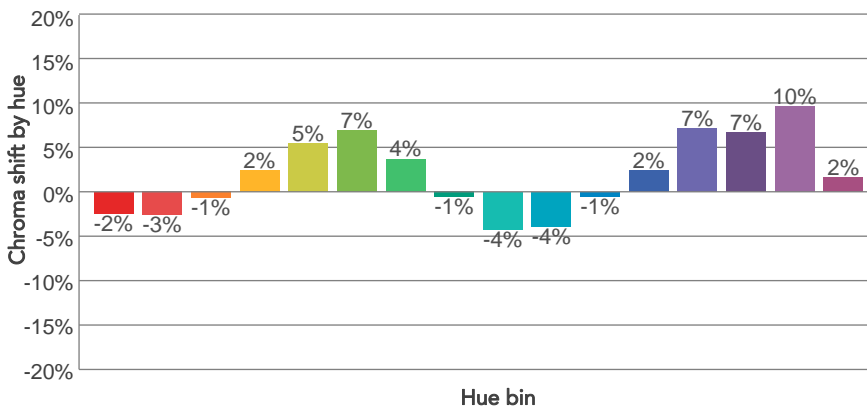
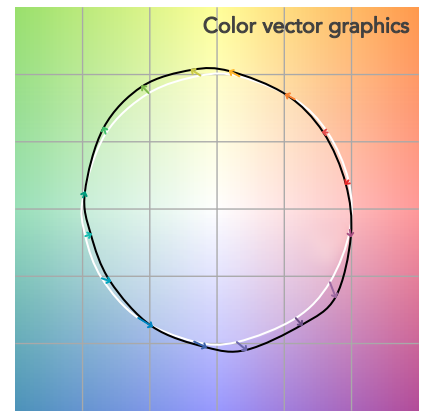
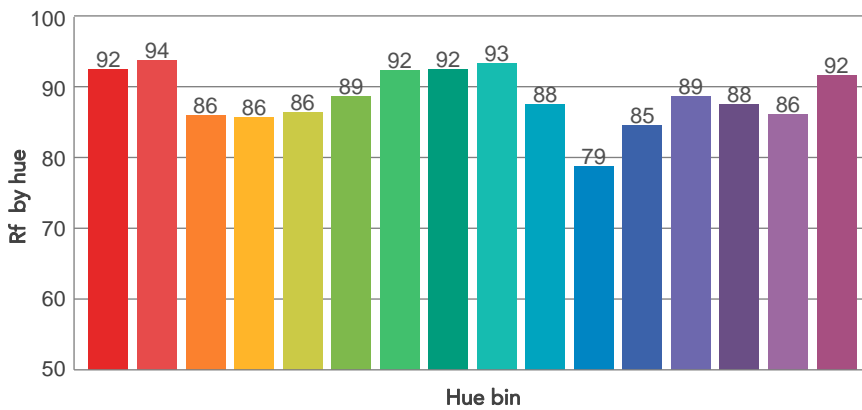
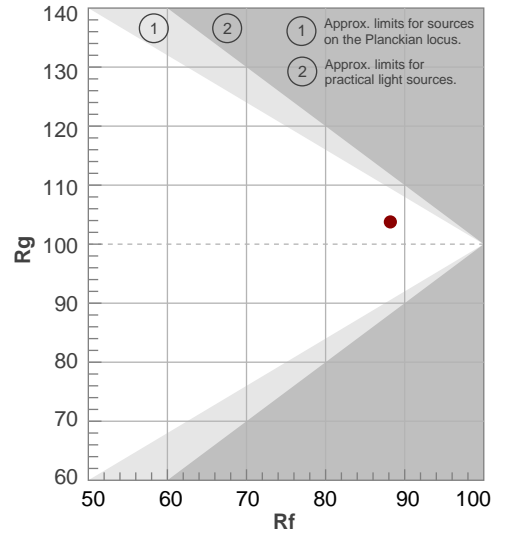

Color Evaluation Sample

BEAM DETAILS



Beam angle 50%	Field angle 10%	Cutoff angle 2,5%	Intensity ratio in 120° cone	Intensity ratio in 90° cone
28,3°	40,6°	50,8°	95,3%	93,8%

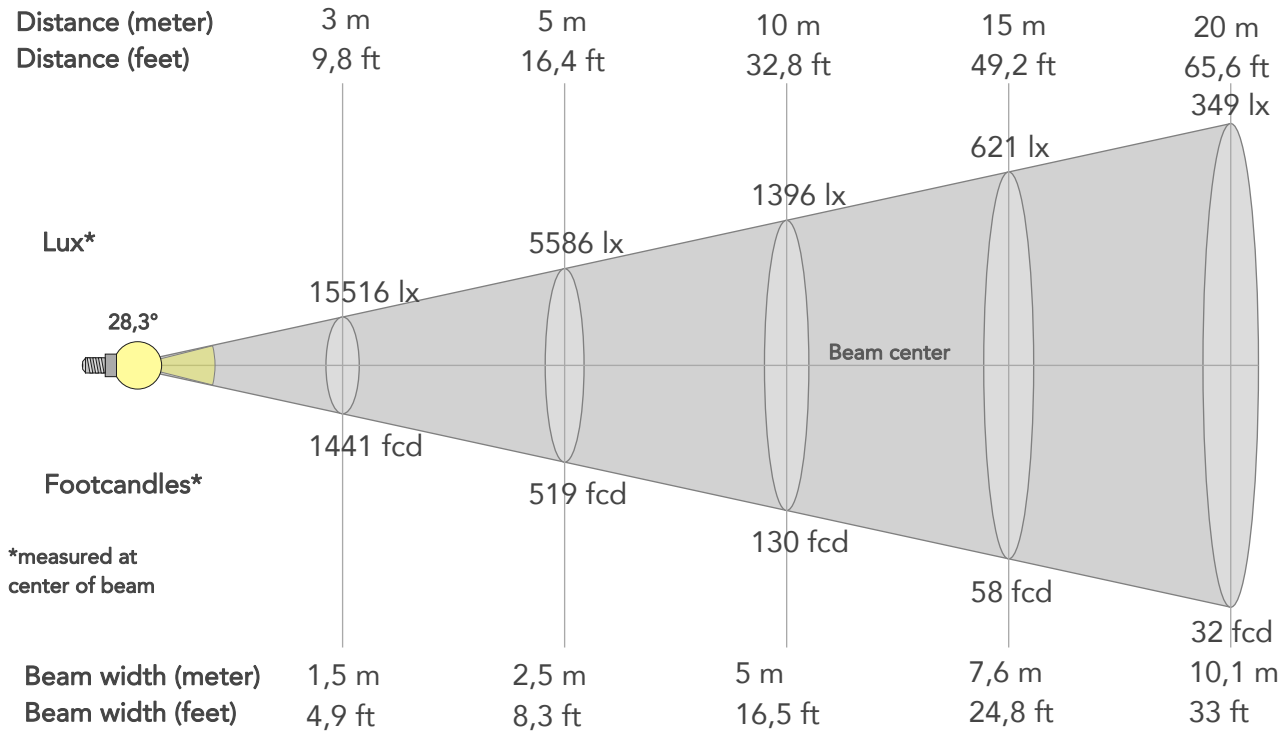

BEAM INTENSITIES AND WIDTHS

Distance	1m	2m	3m	4m	5m	7,5m	10m	15m	20m	25m	30m	40m	50m
Distance	3,3ft	6,6ft	9,8ft	13,1ft	16,4ft	24,6ft	32,8ft	49,2ft	65,6ft	82ft	98,4ft	131,2ft	164ft
Lux	139644lx	34911lx	15516lx	8728lx	5586lx	2483lx	1396lx	621lx	349lx	223lx	155lx	87lx	56lx
Footcand.	12973fcd	3243fcd	1441fcd	811fcd	519fcd	231fcd	130fcd	58fcd	32fcd	21fcd	14fcd	8fcd	5fcd
Beam wid.	0,5m	1m	1,5m	2m	2,5m	3,8m	5m	7,6m	10,1m	12,6m	15,1m	20,1m	25,2m
Beam wid.	1,7ft	3,3ft	4,9ft	6,6ft	8,3ft	12,4ft	16,5ft	24,8ft	33ft	41,3ft	49,5ft	66ft	82,5ft

LINEAR DISTRIBUTION DIAGRAM

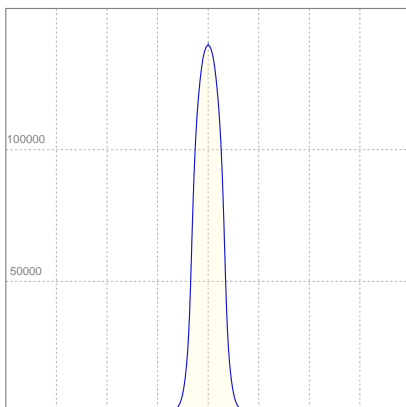

ELECTRICAL SPECIFICATIONS

Input voltage	Input current	Input power	Effeciency
223V	2,11A	457,6W	71lm/W

ISO CANDELA DIAGRAM

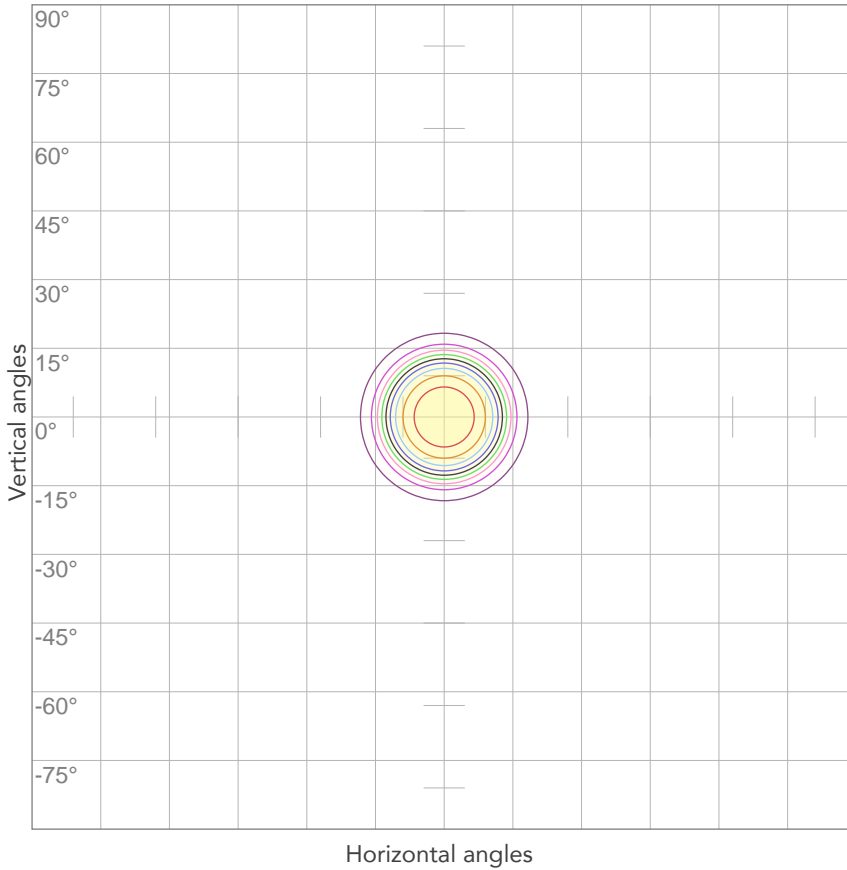

10%	13964 cd
20%	27929 cd
30%	41893 cd
40%	55858 cd
50%	69822 cd
60%	83787 cd
70%	97751 cd
80%	111715 cd

Conditions:

Number of c-planes: 2

Candela at center: 139644 cd

ISO LUX DIAGRAM

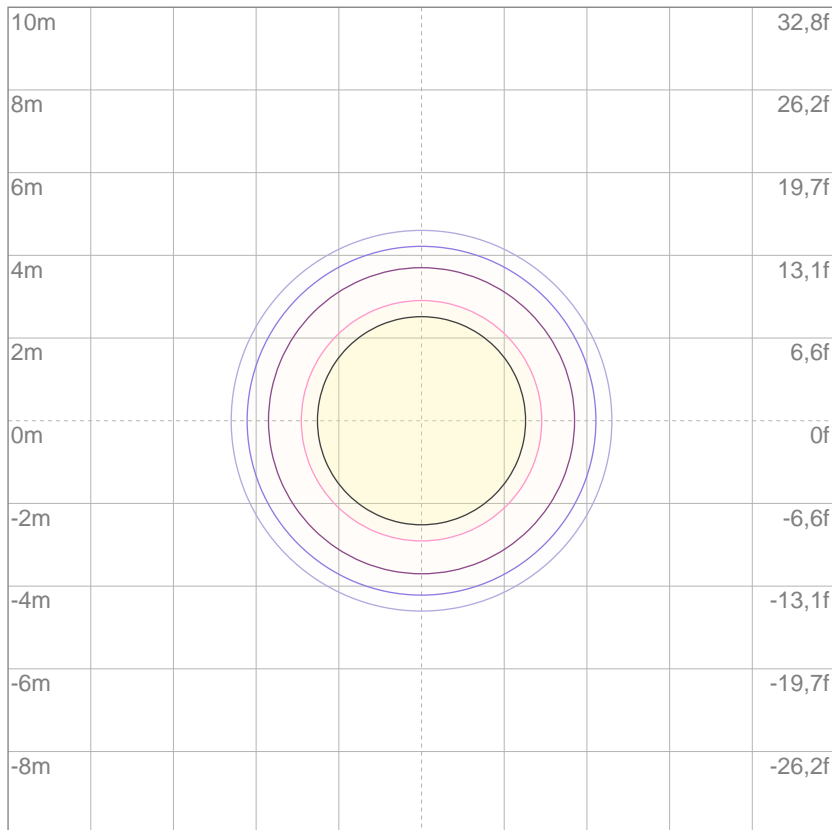

3%	41,9 lx
5%	69,8 lx
10%	140 lx
30%	419 lx
50%	698 lx

Conditions:

Number of c-planes: 2

Lux at center: 1396 lx

Lux distribution on a surface when lamp is mounted at 10 meters from the surface.

Mounting height: 10 meters (33 feet)



Total lumen output:

26255 lm

Total candela output:

299374 cd

Light quality:

CRI: 91,3

Color temperature:

5618 K

PRODUCT NAME:

EclipseFresnel2kDY

MEASUREMENT CONDITIONS:

Beam angle:

15°

Target:

5600K

Operator:

Paolo Carvone

Date and time:

30/01/2020 13:17:10

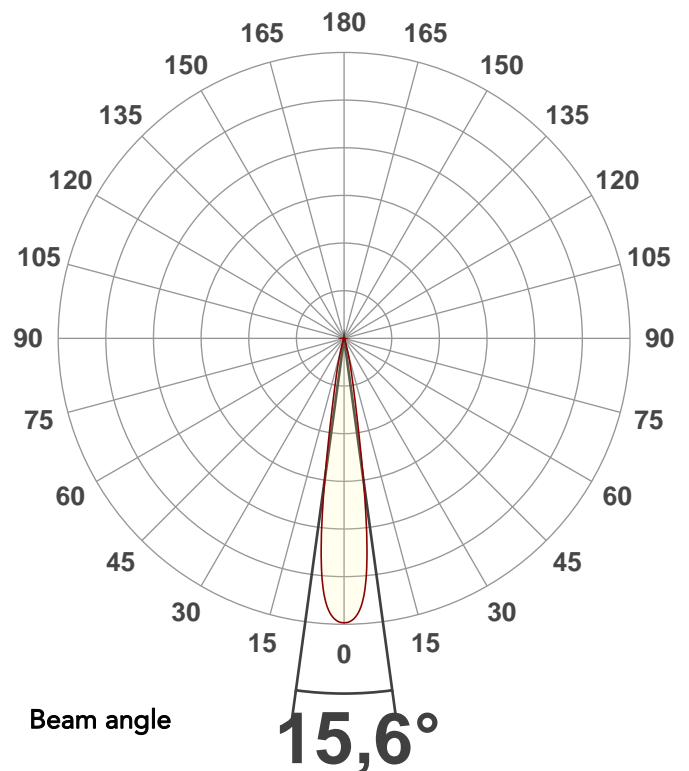

Spectra

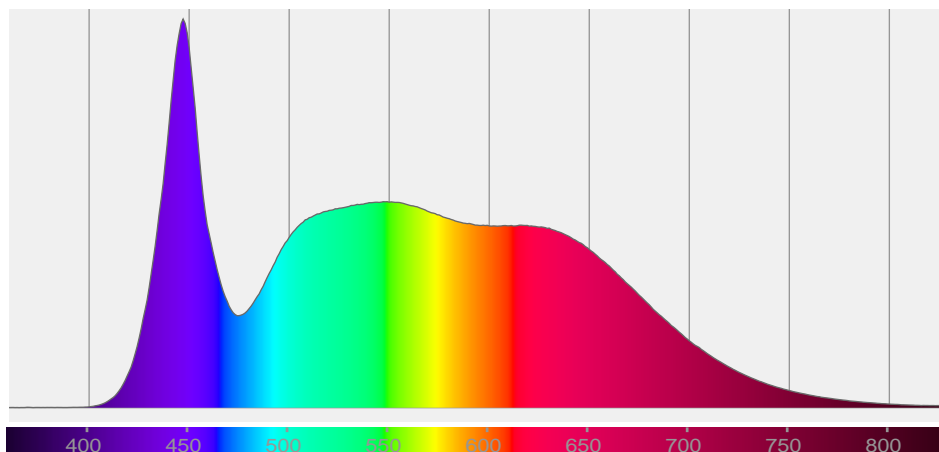

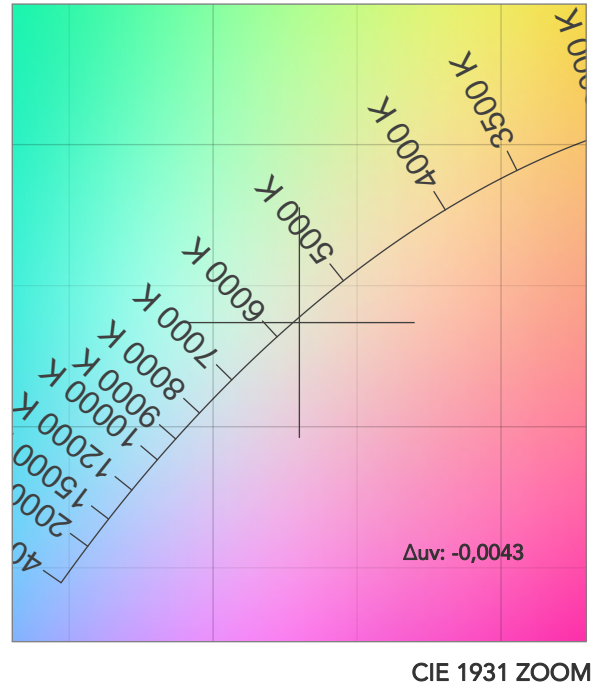
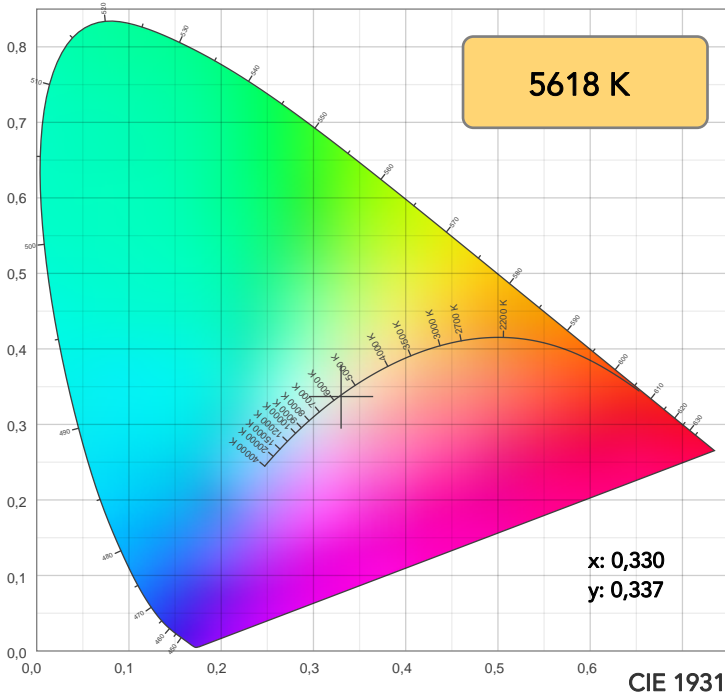

TM30: 88,1

CRI: 91,3 (R1-R8)

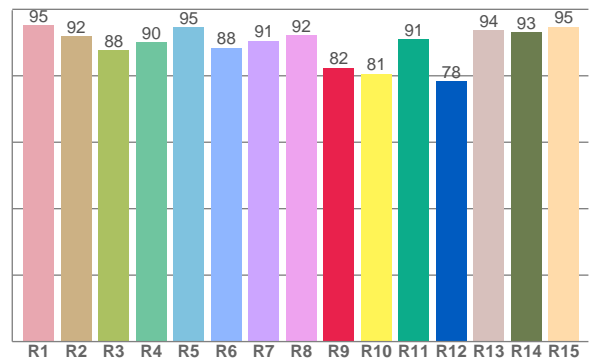
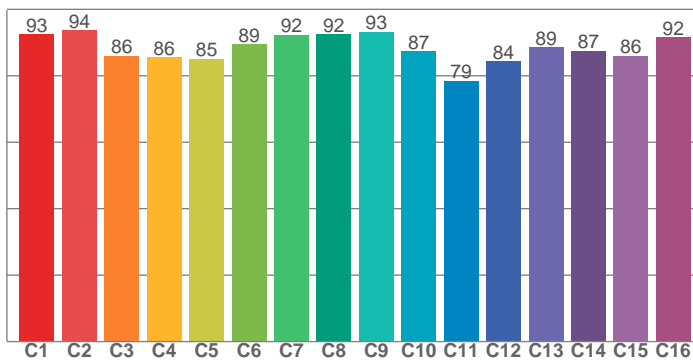

CRI R values, only R1-R8 are used to calculate final CRI value

R1	R2	R3	R4	R5	R6	R7	R8	R9	R10	R11	R12	R13	R14	R15
95,1	92,0	87,8	90,2	94,6	88,4	90,5	92,1	82,4	80,6	91,1	78,3	93,7	93,0	94,8

TM30 C values, 16 binned values out of total of 99 C values

C1	C2	C3	C4	C5	C6	C7	C8	C9	C10	C11	C12	C13	C14	C15	C16
92,5	93,7	85,9	85,6	85,1	89,4	92,3	92,5	93,2	87,3	78,5	84,3	88,5	87,5	86,0	91,6

CQS Q values

Q1	Q2	Q3	Q4	Q5	Q6	Q7	Q8	Q9	Q10	Q11	Q12	Q13	Q14	Q15
95,1	94,7	81,6	85,2	91,7	90,6	91,9	97,8	93,0	88,0	88,3	90,1	92,7	93,3	94,0

CQS: 90,3

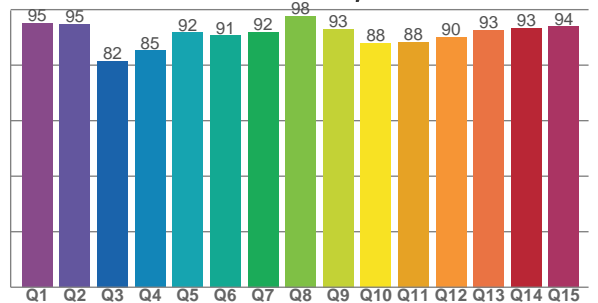

COLOR PARAMETERS

Color temperature	Color rendering index	Red component	Color fidelity	Color gamut	Color quality scale	Television lighting index	Color coordinate cie 1931	Color coordinate cie 1931	Color deviation from black body
CCT	CRI	CRI R9	TM30 Rf	TM30 Rg	CQS	TLCI	x	y	Δuv
5618 K	91,3	82,4	88,1	103,8	90,3	93	0,330	0,337	-0,0043

TM30 DETAILS

Rf 88,1
Fidelity index Rf

Rg 103,8
Gammut index

Hue Bin	R _f	Graphic shifts (%)	
		Chroma	Hue
1	93	-2%	-2%
2	94	-3%	2%
3	86	-1%	7%
4	86	2%	8%
5	85	5%	6%
6	89	7%	1%
7	92	4%	-3%
8	92	-1%	-4%
9	93	-4%	0%
10	87	-4%	5%
11	79	0%	12%
12	84	2%	9%
13	89	7%	6%
14	87	7%	1%
15	86	10%	-7%
16	92	2%	-4%

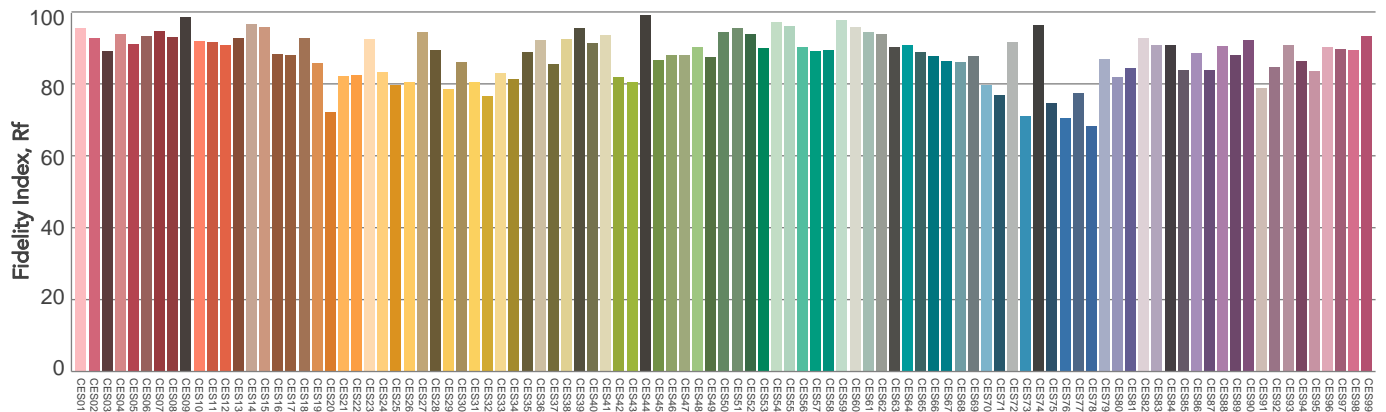
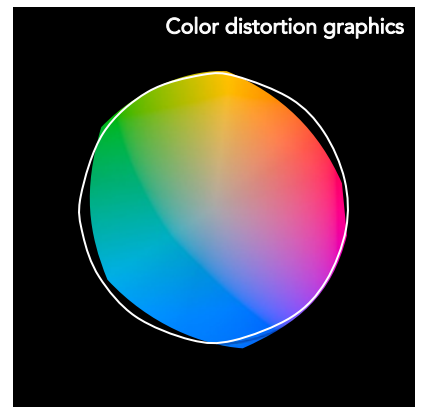
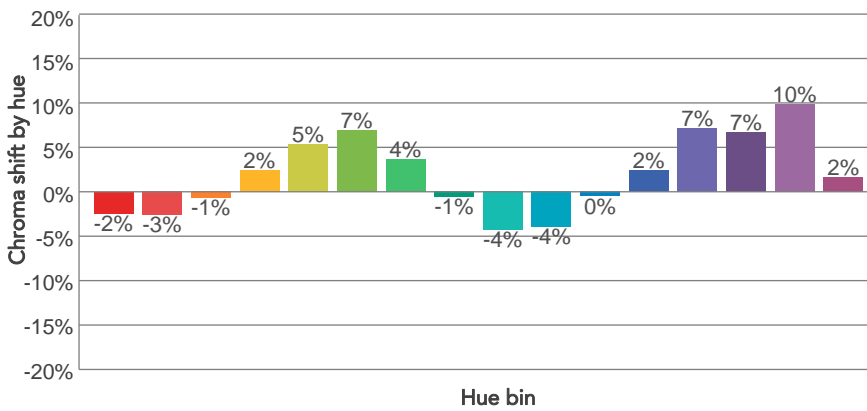
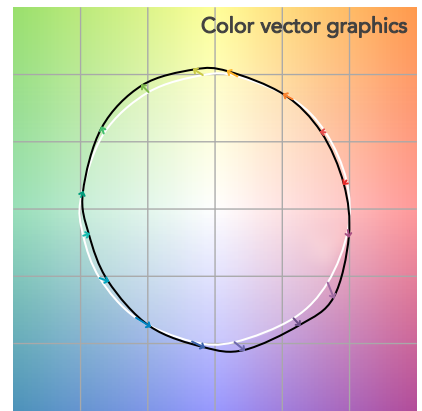
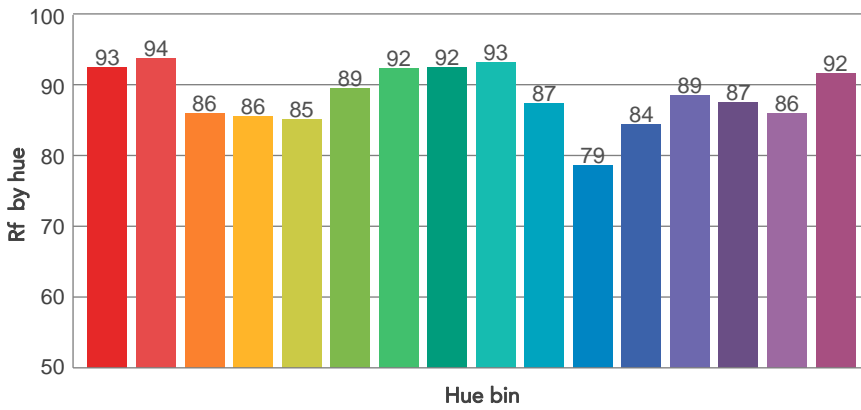
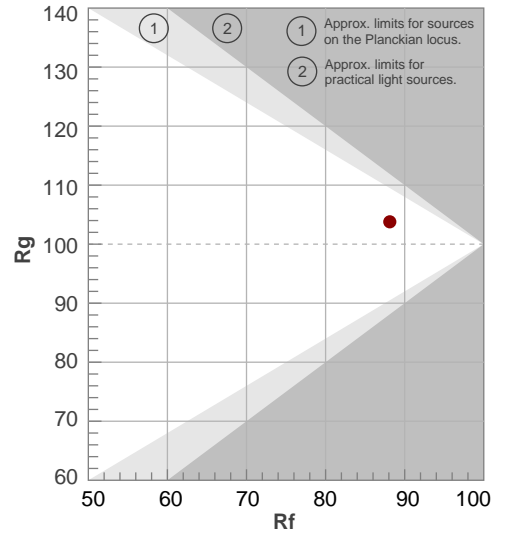

Color Evaluation Sample

BEAM DETAILS



Beam angle 50%	Field angle 10%	Cutoff angle 2,5%	Intensity ratio in 120° cone	Intensity ratio in 90° cone
15,6°	25,8°	35°	94,9%	93,1%

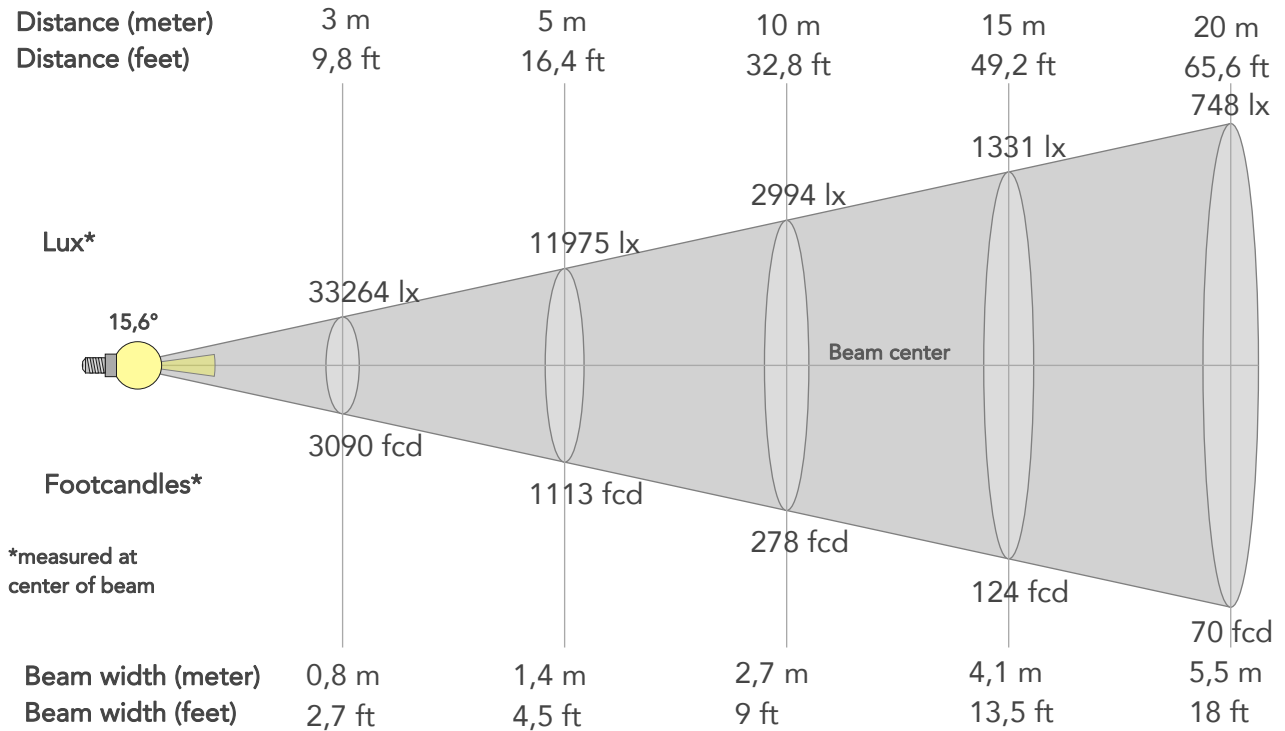

BEAM INTENSITIES AND WIDTHS

Distance	1m	2m	3m	4m	5m	7,5m	10m	15m	20m	25m	30m	40m	50m
Distance	3,3ft	6,6ft	9,8ft	13,1ft	16,4ft	24,6ft	32,8ft	49,2ft	65,6ft	82ft	98,4ft	131,2ft	164ft
Lux	299373lx	74843lx	33264lx	18711lx	11975lx	5322lx	2994lx	1331lx	748lx	479lx	333lx	187lx	120lx
Footcand.	27813fcd	6953fcd	3090fcd	1738fcd	1113fcd	494fcd	278fcd	124fcd	70fcd	45fcd	31fcd	17fcd	11fcd
Beam wid.	0,3m	0,5m	0,8m	1,1m	1,4m	2,1m	2,7m	4,1m	5,5m	6,8m	8,2m	11m	13,7m
Beam wid.	0,9ft	1,8ft	2,7ft	3,6ft	4,5ft	6,7ft	9ft	13,5ft	18ft	22,5ft	26,9ft	35,9ft	44,9ft

LINEAR DISTRIBUTION DIAGRAM

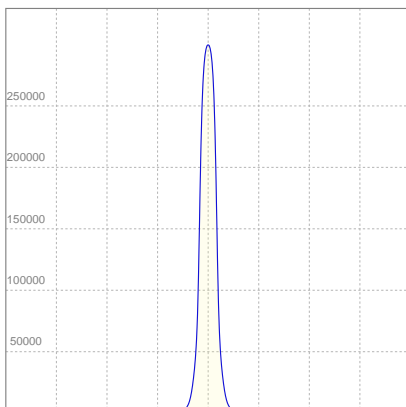

ELECTRICAL SPECIFICATIONS

Input voltage	Input current	Input power	Efficiency
223V	2,11A	458,4W	57lm/W

ISO CANDELA DIAGRAM

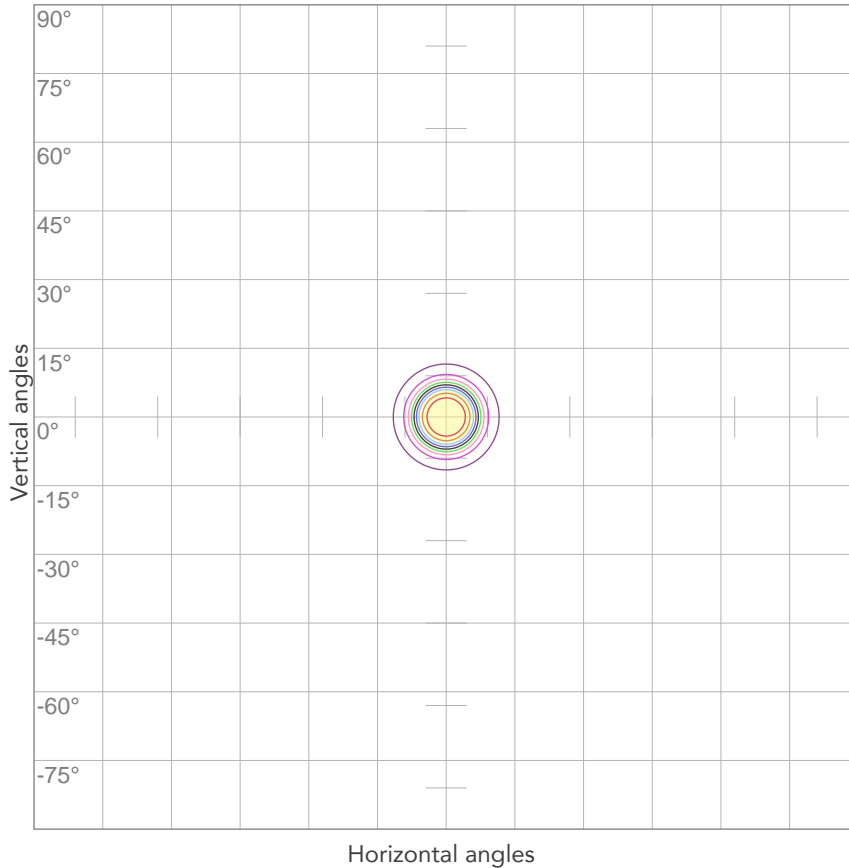

10%	29937 cd
20%	59875 cd
30%	89812 cd
40%	119749 cd
50%	149687 cd
60%	179624 cd
70%	209561 cd
80%	239499 cd

Conditions:

Number of c-planes: 2

Candela at center: 299373 cd

ISO LUX DIAGRAM

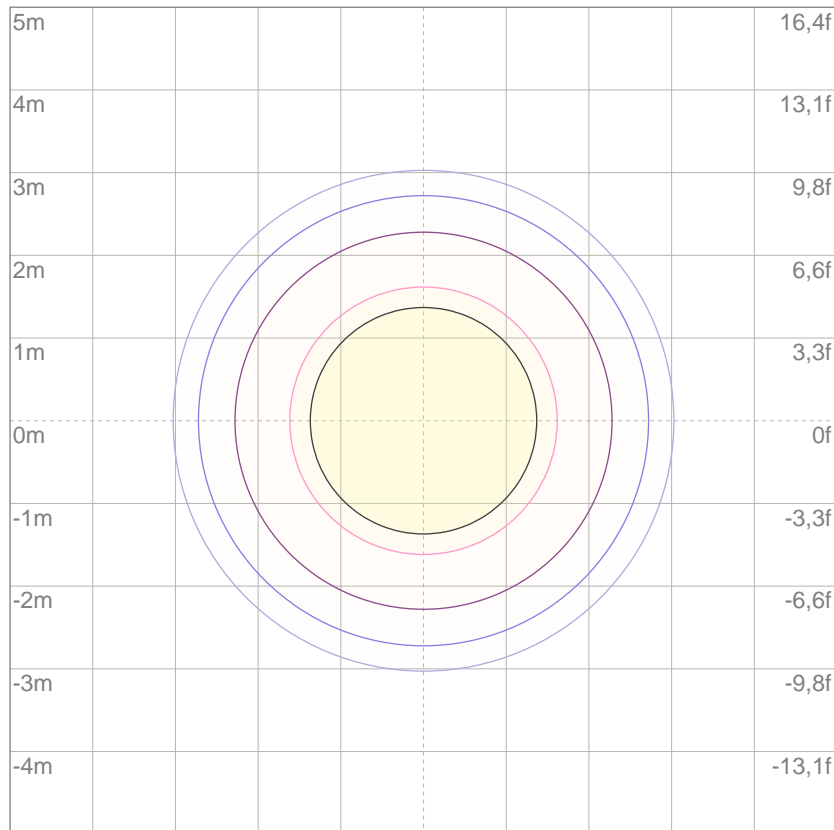

Mounting height: 10 meters (33 feet)

3%	89,8 lx
5%	150 lx
10%	299 lx
30%	898 lx
50%	1497 lx

Conditions:

Number of c-planes: 2

Lux at center: 2994 lx

Lux distribution on a surface when lamp is mounted at 10 meters from the surface.