

# Photometric Test Report



## EclipseFresnel TU

Warm White LED Fresnel Luminaire

## CONTENTS

Table of contents	2
Testing process	2
Color preset Full on	
Beam angle 45°	3
Beam angle 30°	8
Beam angle 15°	13

## TESTING PROCESS

Prolights has its own optical testing laboratory in order to provide accurate photometric reports for its lighting products. The testing laboratory contains certain variety of precise lighting measurement systems that ensure an optimal reading of all the characteristic parameters of the lighting devices. All measurements are made at a controlled room temperature of 20°C without any external light sources. This photometric report is obtained through the data measured by a high precision measurement system and analyzed by a dedicate software.

### Prolights measurement instrument

Prolights measurement instrument is a complete measurement system for any light source. It's equipped with two-axis goniometer, that enables to measure the full 3D distribution field of the light source. This instrument measures the light intensity, the beam angle and the most significative colors parameters, like color temperature, spectral distribution, CRI, CQS, TM-30 with a very high accuracy rate.

**Please Note:** All measurements are made with light source at operating temperature. Before starting the measurement, the instrument analyzes the process of the light source during the heating phase. The measuring process of all the parameters begins only when the light emission is stable, that is with a variation of less than 0.5% in a 15 minutes time frame.

### Prolights measurement software

The software provides user friendly interface for the operator who does the measurements, and it also analyzes and processes all the collected data by the instrument. With this software it is possible to see the measured data in real-time and it is possible to examine all the measured data and graphics afterwards as well. All information is collected in a specific Prolights template, and the software creates also IES and LDT files, which are widely used to transfer the photometric data, and to develop lighting system.

Additionally, the fixtures are rechecked using various hand-held instruments like Sekonic C-700 and Gossen Mavospec Base, this is done to ensure, that the data in the photometric report are as accurate as possible.



Total lumen output:

13320 lm

Total candela output:

25464 cd

Light quality:

CRI: 97,9

Color temperature:

3223 K

## PRODUCT NAME:

EclipseFresnel TU

## MEASUREMENT CONDITIONS:

Beam angle:

45°

Target:

3200K

Operator:

Paolo Carvone

Date and time:

22/01/2020 14:50:45

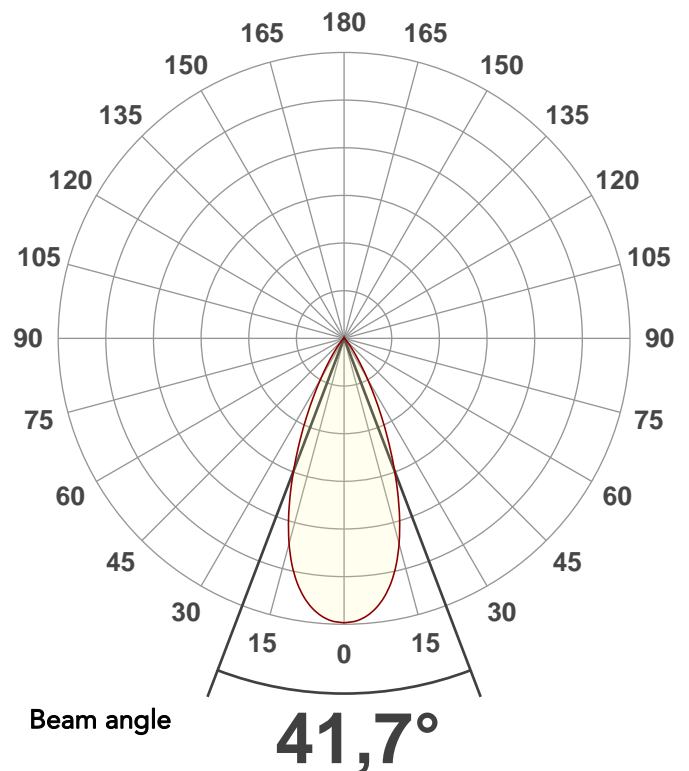

Spectra

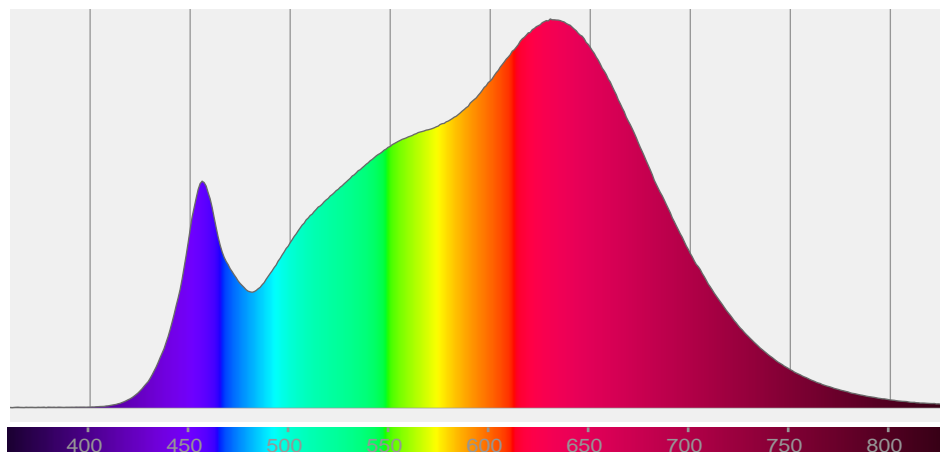

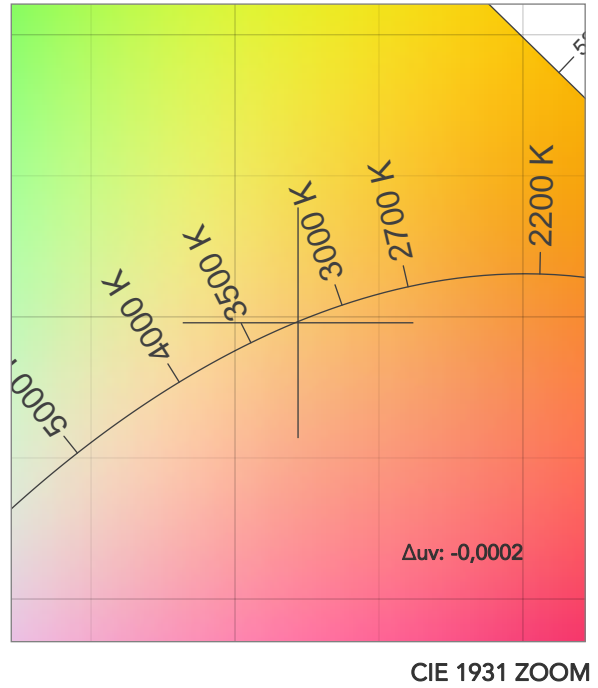
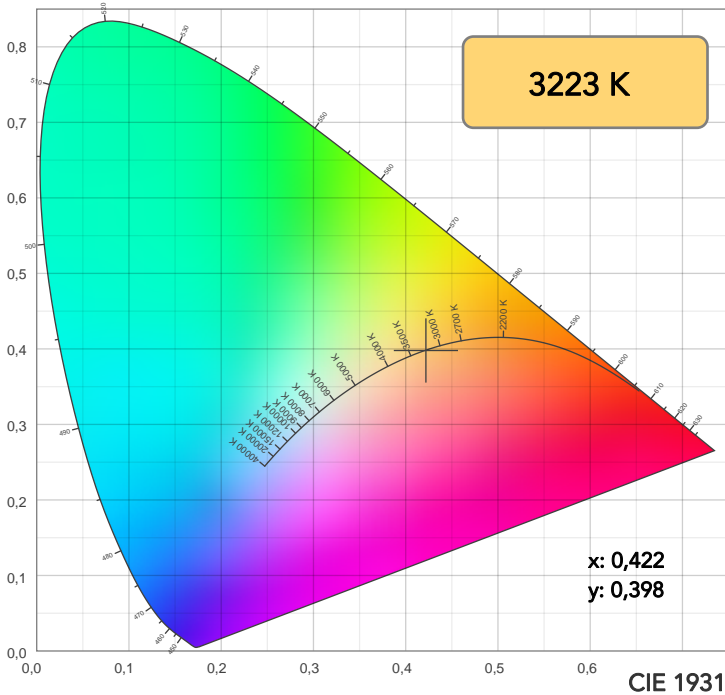

TM30: 92,9

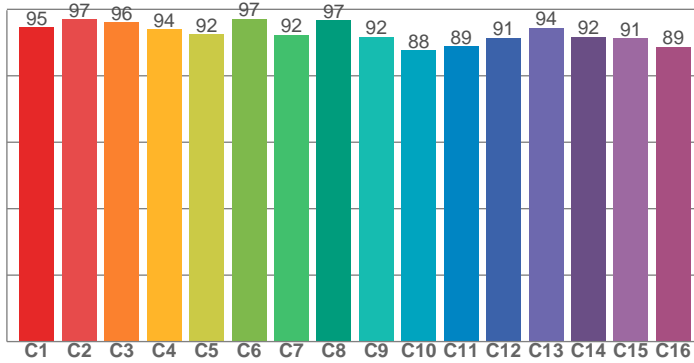

CRI: 97,9 (R1-R8)

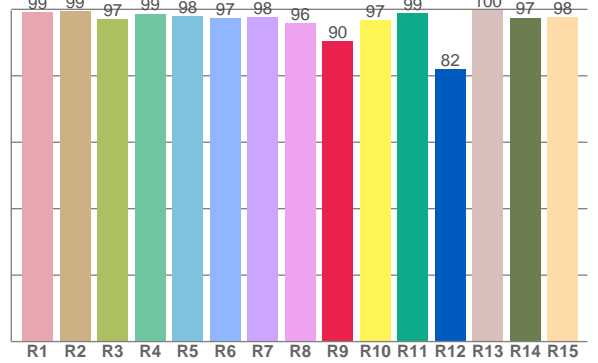

CQS: 95,0

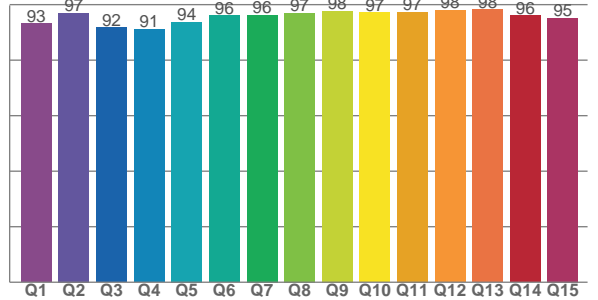

CRI R values, only R1-R8 are used to calculate final CRI value

R1	R2	R3	R4	R5	R6	R7	R8	R9	R10	R11	R12	R13	R14	R15
99,1	99,4	97,0	98,7	97,9	97,4	97,6	95,8	90,4	96,7	98,8	82,0	99,6	97,4	97,7

TM30 C values, 16 binned values out of total of 99 C values

C1	C2	C3	C4	C5	C6	C7	C8	C9	C10	C11	C12	C13	C14	C15	C16
94,6	96,9	96,0	94,0	92,5	97,2	92,2	96,6	91,8	87,7	88,8	91,4	94,5	91,7	91,2	88,7

CQS Q values

Q1	Q2	Q3	Q4	Q5	Q6	Q7	Q8	Q9	Q10	Q11	Q12	Q13	Q14	Q15
93,2	97,0	91,7	91,1	93,8	96,1	96,2	97,0	97,7	97,1	97,3	98,0	98,2	96,1	95,2

COLOR PARAMETERS

Color temperature	Color rendering index	Red component	Color fidelity	Color gamut	Color quality scale	Television lighting index	Color coordinate cie 1931	Color coordinate cie 1931	Color deviation from black body
CCT	CRI	CRI R9	TM30 Rf	TM30 Rg	CQS	TLCI	x	y	Δuv
3223 K	97,9	90,4	92,9	99,7	95,0	98	0,422	0,398	-0,0002

# TM30 DETAILS

**Rf 92,9**  
Fidelity index Rf

**Rg 99,7**  
Gammut index

Hue Bin	R <sub>f</sub>	Graphic shifts (%)	
		Chroma	Hue
1	95	-1%	1%
2	97	-1%	0%
3	96	-1%	1%
4	94	-3%	-1%
5	92	-5%	0%
6	97	-1%	1%
7	92	-3%	3%
8	97	-1%	2%
9	92	0%	5%
10	88	1%	7%
11	89	3%	6%
12	91	5%	0%
13	94	1%	-3%
14	92	4%	-4%
15	91	0%	-2%
16	89	1%	-8%

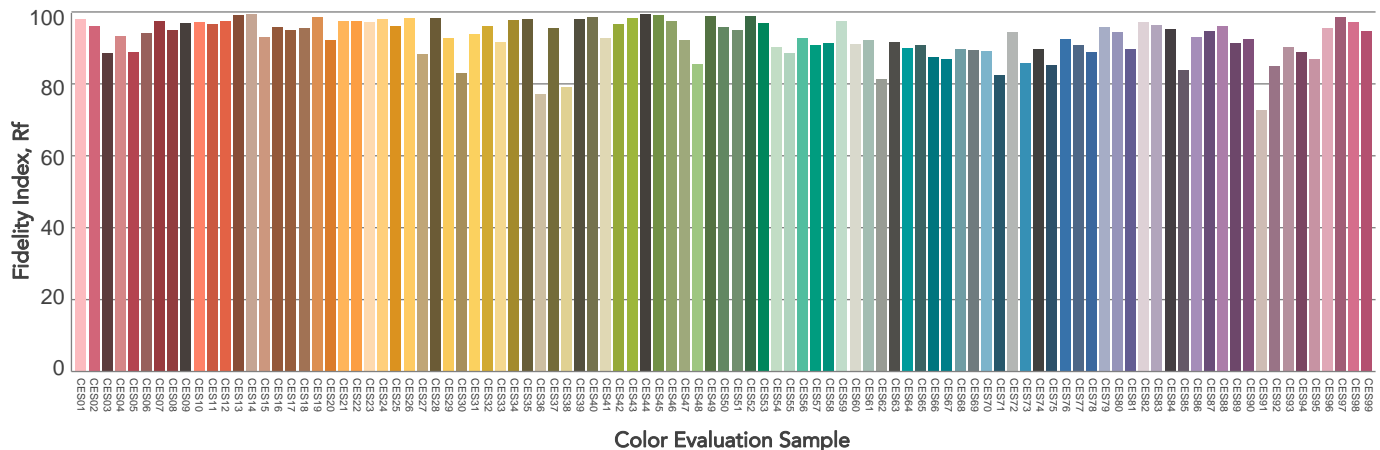
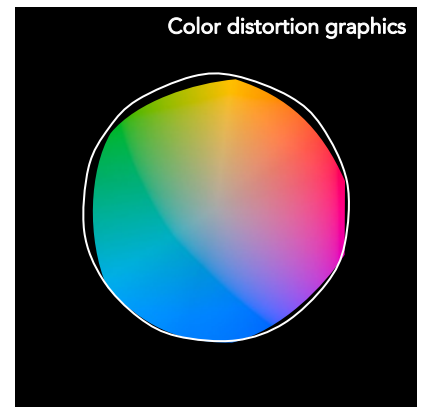
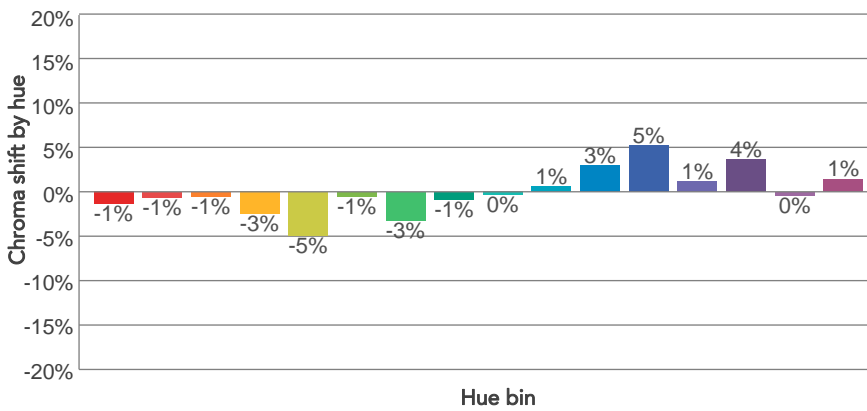
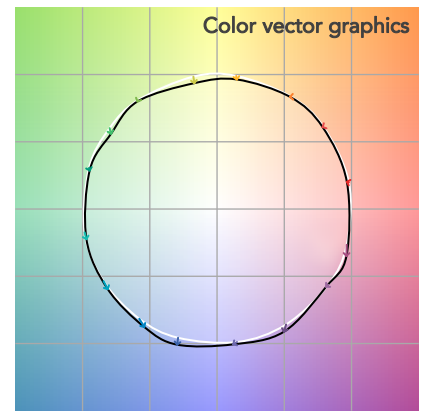
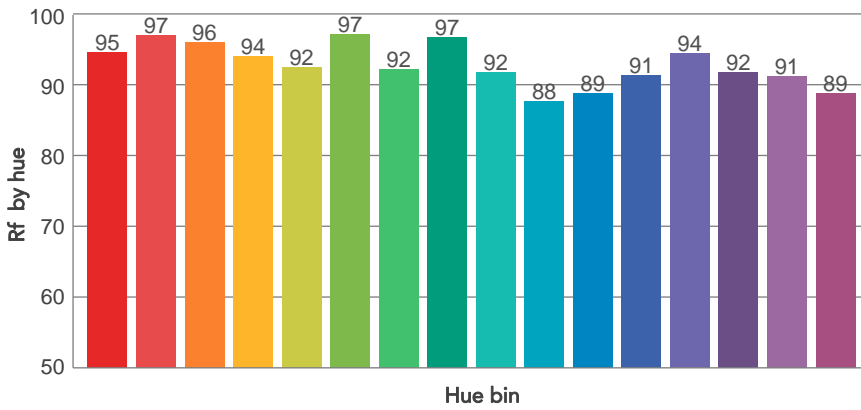
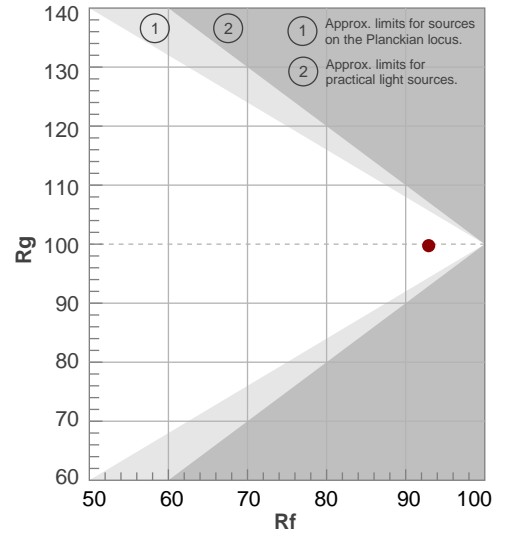

# BEAM DETAILS



Beam angle 50%	Field angle 10%	Cutoff angle 2,5%	Intensity ratio in 120° cone	Intensity ratio in 90° cone
41,7°	66,1°	81,4°	97,0%	95,3%

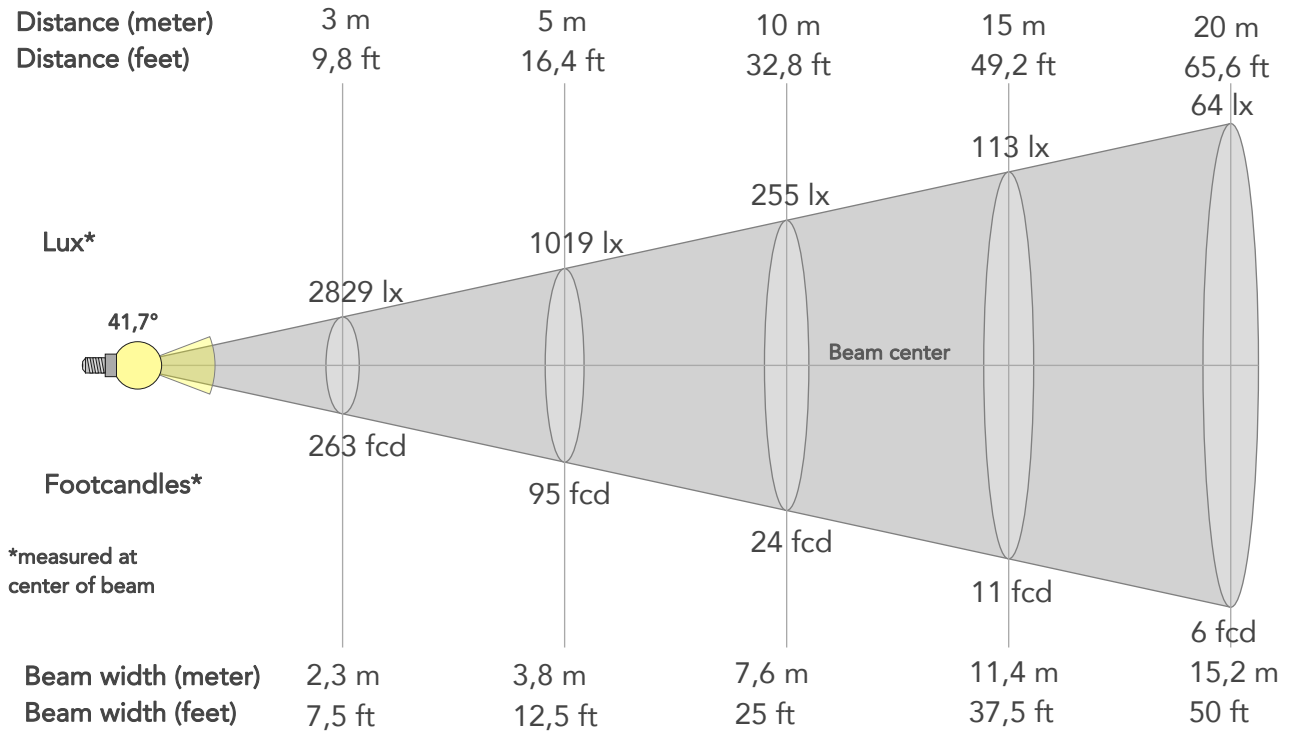

## BEAM INTENSITIES AND WIDTHS

Distance	1m	2m	3m	4m	5m	7,5m	10m	15m	20m	25m	30m	40m	50m
Distance	3,3ft	6,6ft	9,8ft	13,1ft	16,4ft	24,6ft	32,8ft	49,2ft	65,6ft	82ft	98,4ft	131,2ft	164ft
Lux	25464lx	6366lx	2829lx	1591lx	1019lx	453lx	255lx	113lx	64lx	41lx	28lx	16lx	10lx
Footcand.	2366fcd	591fcd	263fcd	148fcd	95fcd	42fcd	24fcd	11fcd	6fcd	4fcd	3fcd	1fcd	1fcd
Beam wid.	0,8m	1,5m	2,3m	3m	3,8m	5,7m	7,6m	11,4m	15,2m	19,1m	22,9m	30,5m	38,1m
Beam wid.	2,5ft	5ft	7,5ft	10ft	12,5ft	18,7ft	25ft	37,5ft	50ft	62,5ft	75ft	100ft	125ft

## LINEAR DISTRIBUTION DIAGRAM

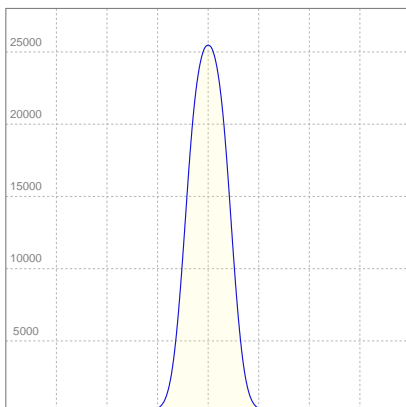

## ELECTRICAL SPECIFICATIONS

Input voltage	Input current	Input power	Effeciency
224V	0,998A	209,1W	64lm/W

## ISO CANDELA DIAGRAM

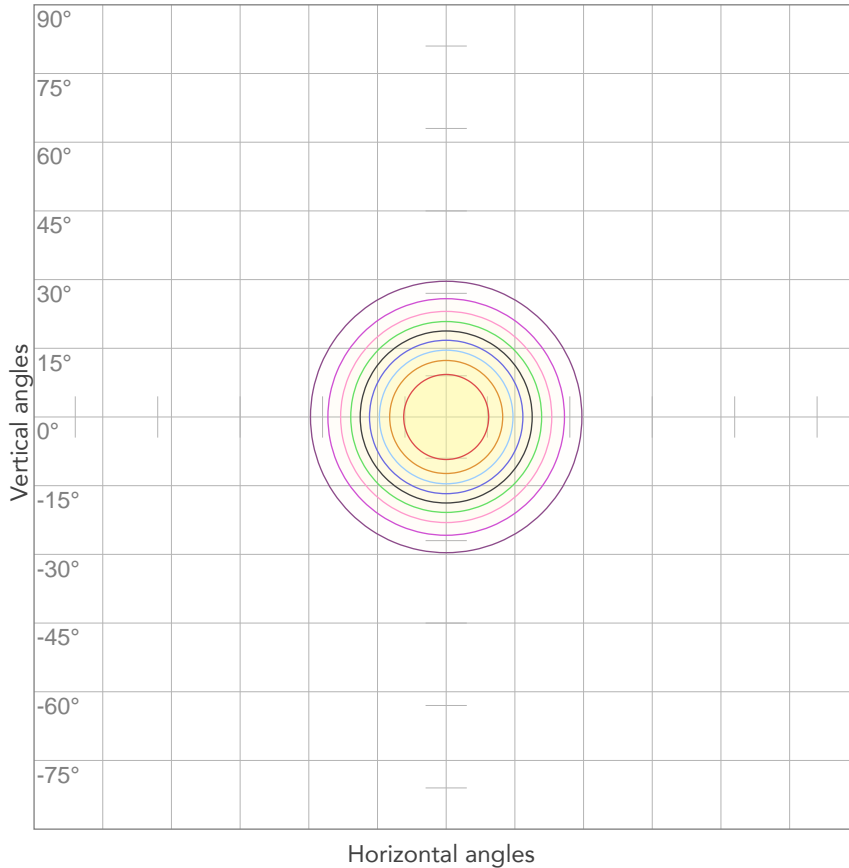

10%	2546 cd
20%	5093 cd
30%	7639 cd
40%	10186 cd
50%	12732 cd
60%	15278 cd
70%	17825 cd
80%	20371 cd

Conditions:

Number of c-planes: 2

Candela at center: 25464 cd

## ISO LUX DIAGRAM

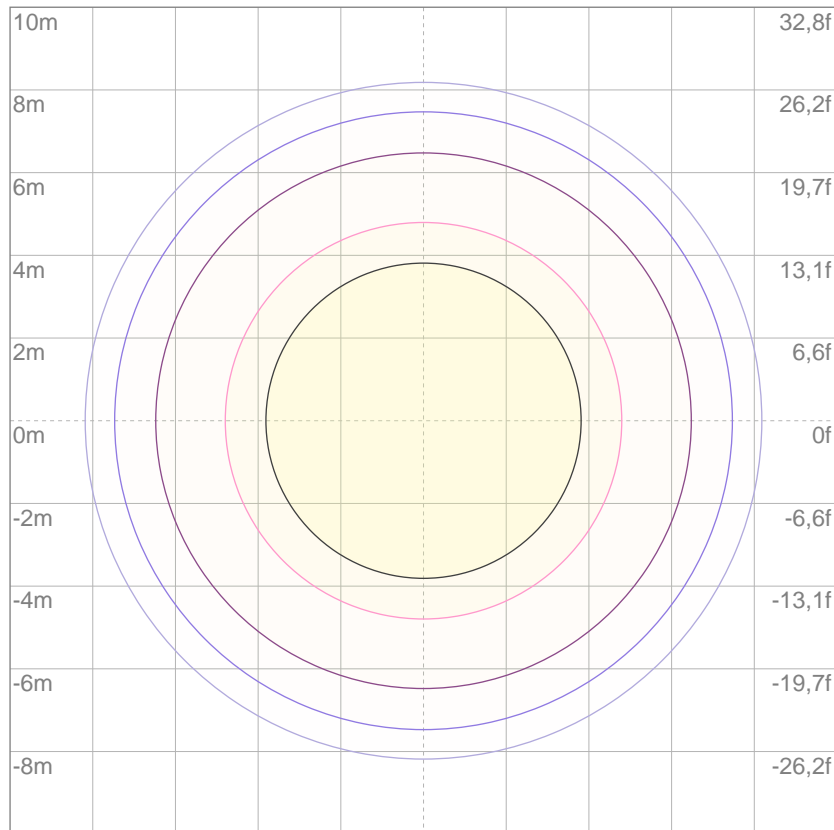

Mounting height: 10 meters (33 feet)

3%	7,64 lx
5%	12,7 lx
10%	25,5 lx
30%	76,4 lx
50%	127 lx

Conditions:

Number of c-planes: 2

Lux at center: 255 lx

*Lux distribution on a surface when lamp is mounted at 10 meters from the surface.*



Total lumen output:

12496 lm

Total candela output:

62548 cd

Light quality:

CRI: 97,8

Color temperature:

3244 K

## PRODUCT NAME:

EclipseFresnel TU

## MEASUREMENT CONDITIONS:

Beam angle:

30°

Target:

3200K

Operator:

Paolo Carvone

Date and time:

22/01/2020 14:48:11

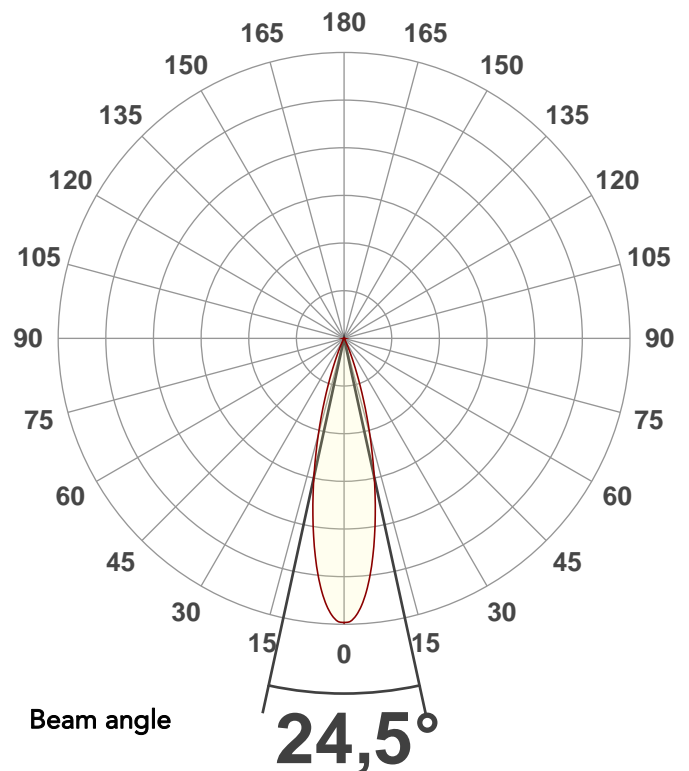

Spectra

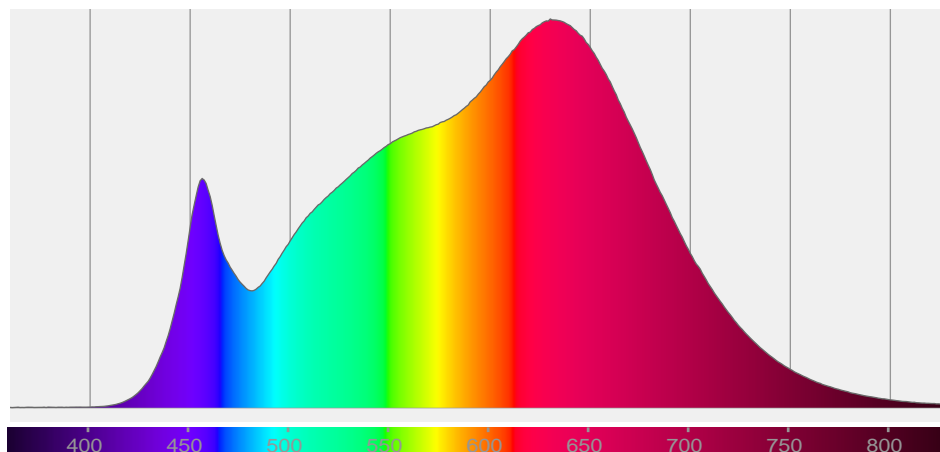



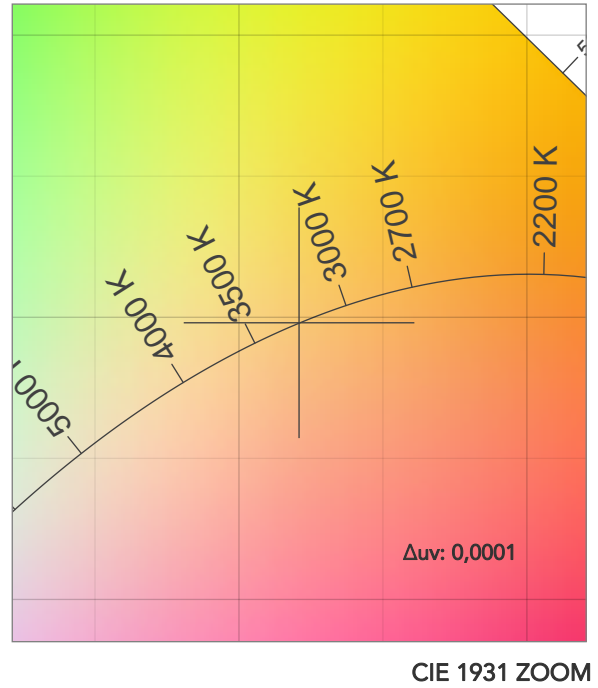
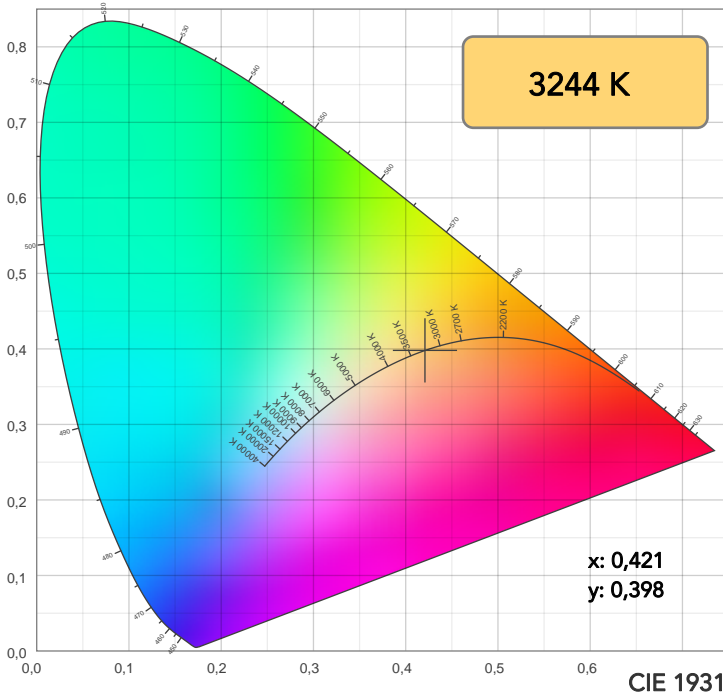

TM30: 92,8

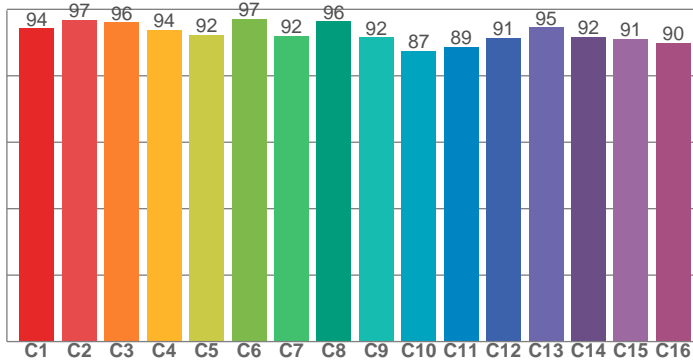

CRI: 97,8 (R1-R8)

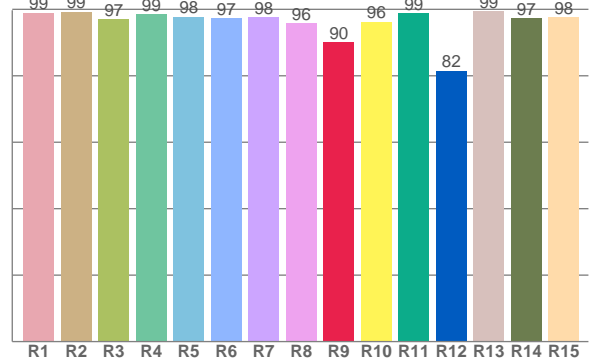

CQS: 95,0

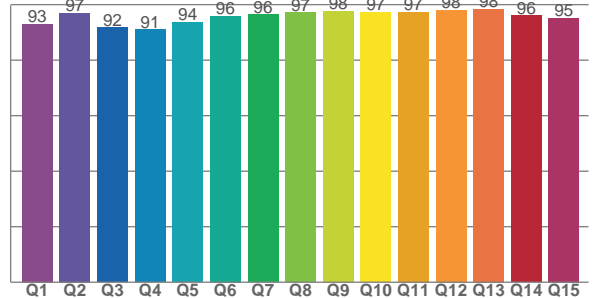

CRI R values, only R1-R8 are used to calculate final CRI value

R1	R2	R3	R4	R5	R6	R7	R8	R9	R10	R11	R12	R13	R14	R15
99,0	99,3	96,9	98,5	97,7	97,3	97,7	95,8	90,1	96,3	98,7	81,6	99,5	97,4	97,5

TM30 C values, 16 binned values out of total of 99 C values

C1	C2	C3	C4	C5	C6	C7	C8	C9	C10	C11	C12	C13	C14	C15	C16
94,2	96,9	96,0	93,8	92,3	97,1	92,0	96,4	91,6	87,4	88,7	91,4	94,5	91,7	91,1	89,9

CQS Q values

Q1	Q2	Q3	Q4	Q5	Q6	Q7	Q8	Q9	Q10	Q11	Q12	Q13	Q14	Q15
93,1	97,0	91,7	91,0	93,7	95,9	96,4	97,2	97,7	97,2	97,4	98,1	98,4	96,1	95,2

COLOR PARAMETERS

Color temperature	Color rendering index	Red component	Color fidelity	Color gamut	Color quality scale	Television lighting index	Color coordinate cie 1931	Color coordinate cie 1931	Color deviation from black body
CCT	CRI	CRI R9	TM30 Rf	TM30 Rg	CQS	TLCI	x	y	Δuv
3244 K	97,8	90,1	92,8	99,6	95,0	98	0,421	0,398	0,0001

# TM30 DETAILS

**Rf 92,8**  
Fidelity index Rf

**Rg 99,6**  
Gammut index

Hue Bin	R <sub>f</sub>	Graphic shifts (%)	
		Chroma	Hue
1	94	-1%	1%
2	97	-1%	0%
3	96	-1%	1%
4	94	-3%	-1%
5	92	-5%	0%
6	97	-1%	1%
7	92	-3%	3%
8	96	-1%	2%
9	92	0%	5%
10	87	1%	7%
11	89	3%	7%
12	91	5%	0%
13	95	1%	-3%
14	92	4%	-4%
15	91	0%	-2%
16	90	1%	-6%

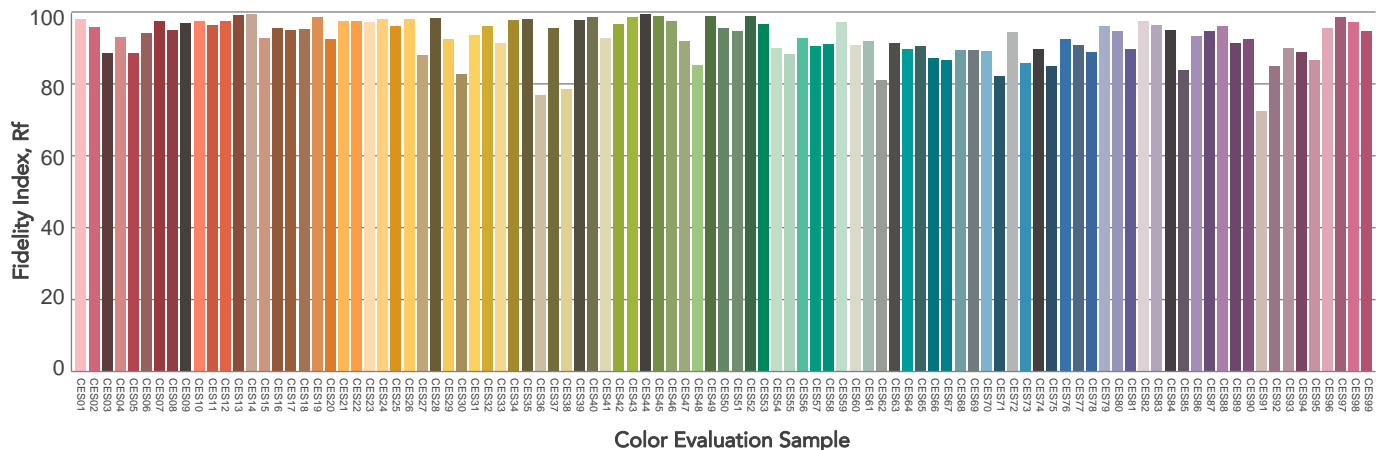
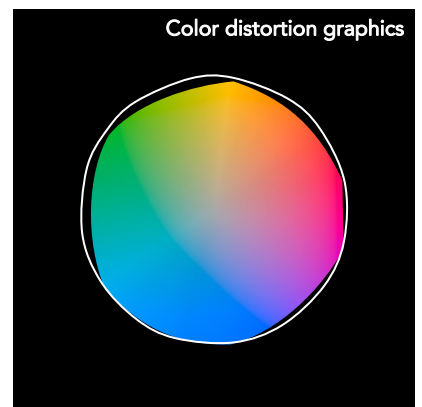
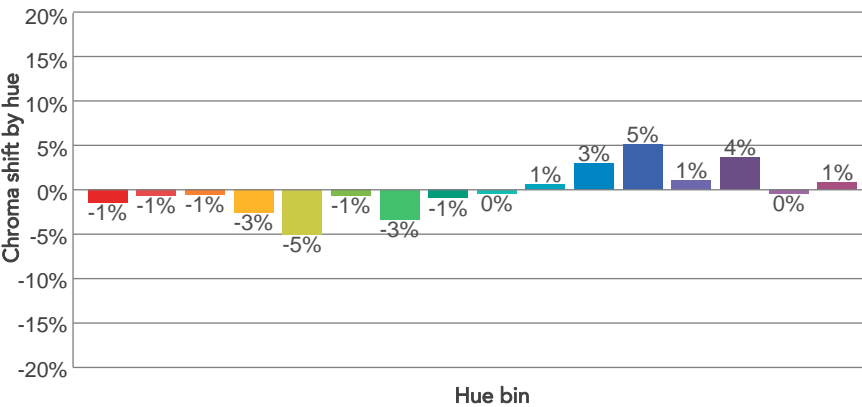
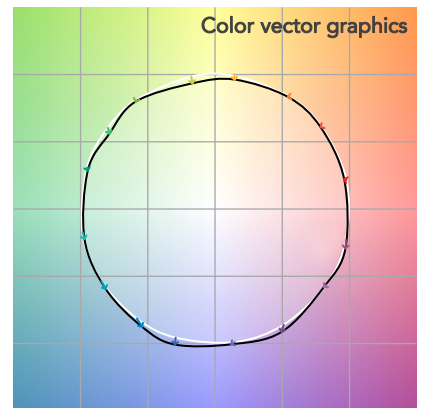
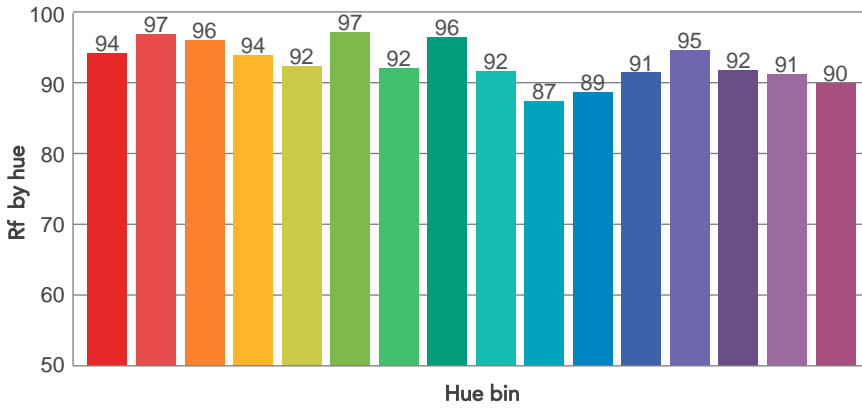
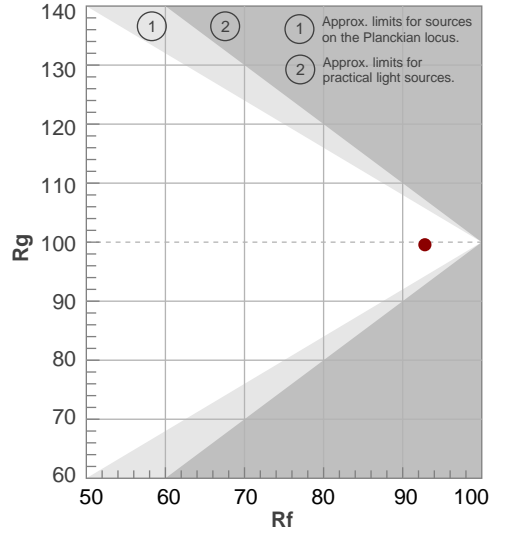

# BEAM DETAILS



Beam angle 50%	Field angle 10%	Cutoff angle 2,5%	Intensity ratio in 120° cone	Intensity ratio in 90° cone
24,5°	42,1°	50,9°	97,7%	96,4%

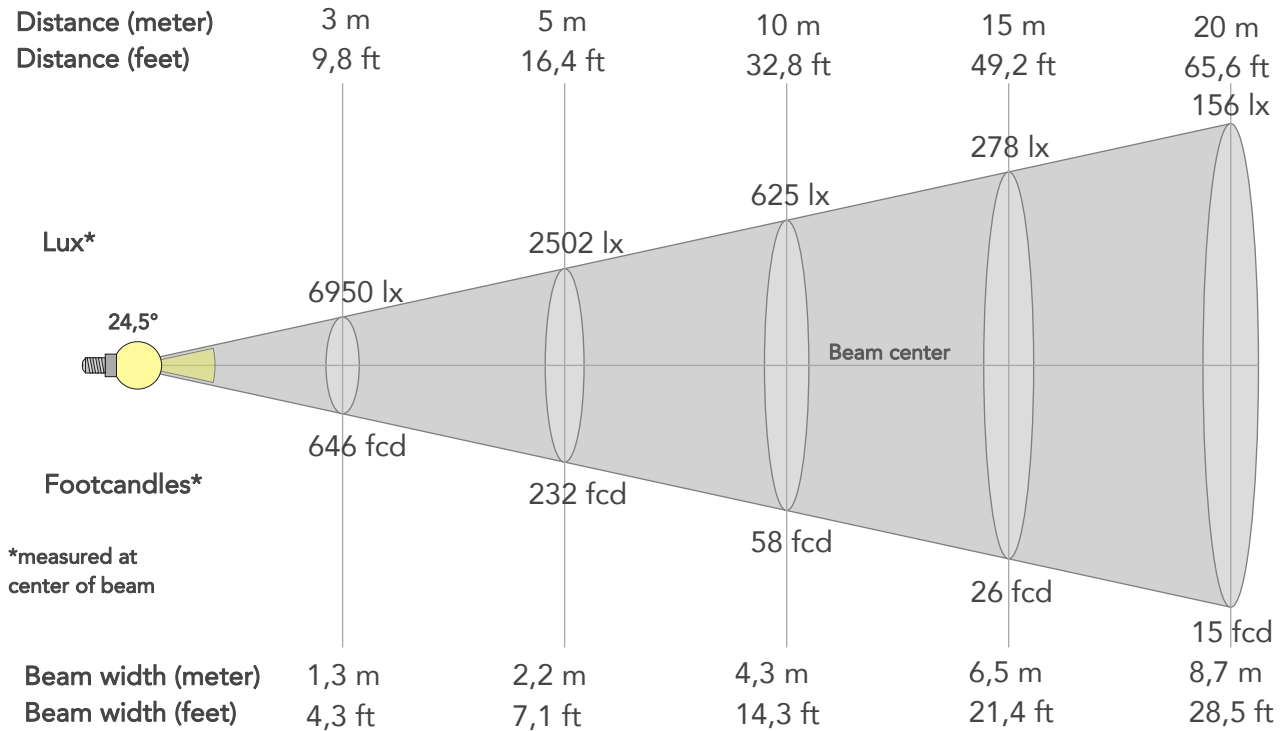

## BEAM INTENSITIES AND WIDTHS

Distance	1m	2m	3m	4m	5m	7,5m	10m	15m	20m	25m	30m	40m	50m
Distance	3,3ft	6,6ft	9,8ft	13,1ft	16,4ft	24,6ft	32,8ft	49,2ft	65,6ft	82ft	98,4ft	131,2ft	164ft
Lux	62548lx	15637lx	6950lx	3909lx	2502lx	1112lx	625lx	278lx	156lx	100lx	69lx	39lx	25lx
Footcand.	5811fcd	1453fcd	646fcd	363fcd	232fcd	103fcd	58fcd	26fcd	15fcd	9fcd	6fcd	4fcd	2fcd
Beam wid.	0,4m	0,9m	1,3m	1,7m	2,2m	3,3m	4,3m	6,5m	8,7m	10,9m	13m	17,4m	21,7m
Beam wid.	1,4ft	2,9ft	4,3ft	5,7ft	7,1ft	10,7ft	14,3ft	21,4ft	28,5ft	35,7ft	42,8ft	57ft	71,3ft

## LINEAR DISTRIBUTION DIAGRAM

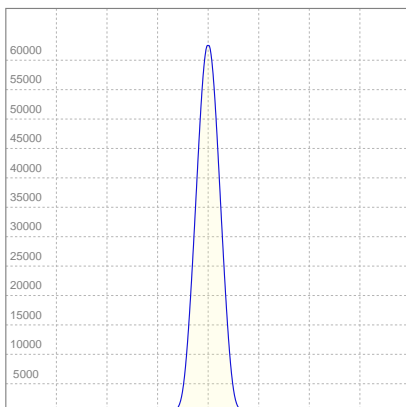

## ELECTRICAL SPECIFICATIONS

Input voltage	Input current	Input power	Effeciency
224V	1,00A	209,7W	60lm/W

## ISO CANDELA DIAGRAM

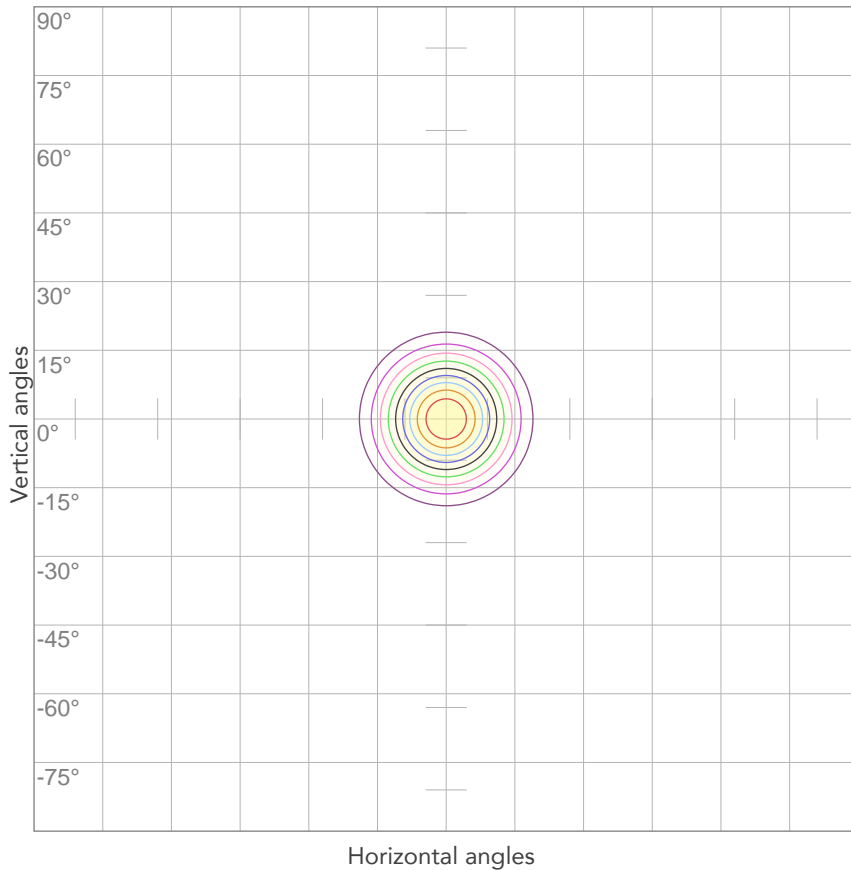

10%	6255 cd
20%	12510 cd
30%	18764 cd
40%	25019 cd
50%	31274 cd
60%	37529 cd
70%	43783 cd
80%	50038 cd

Conditions:

Number of c-planes: 2

Candela at center: 62548 cd

## ISO LUX DIAGRAM

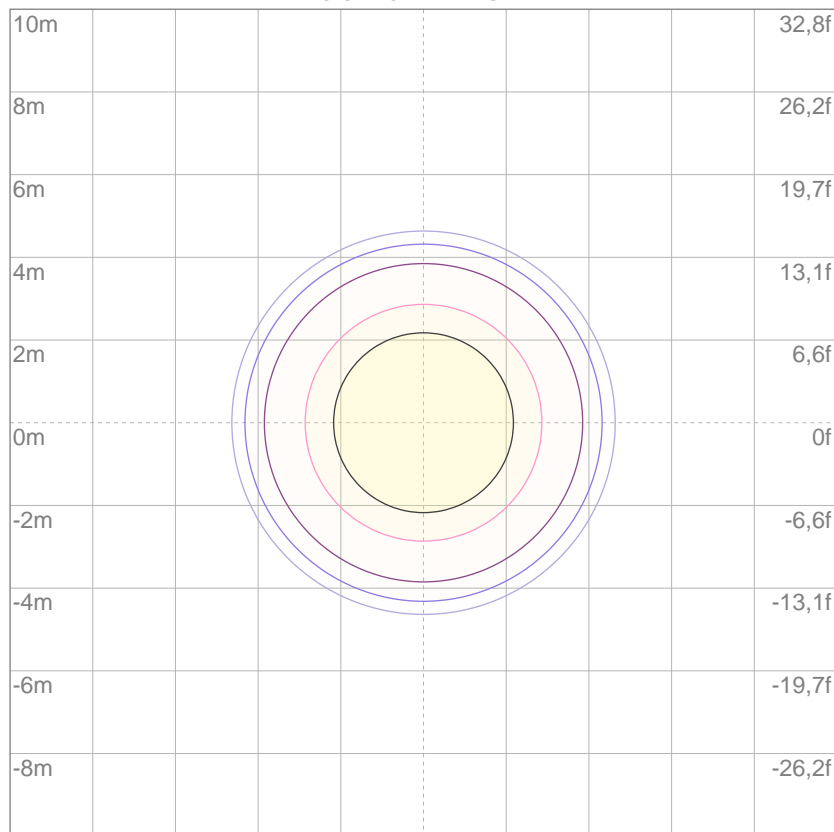

3%	18,8 lx
5%	31,3 lx
10%	62,5 lx
30%	188 lx
50%	313 lx

Conditions:

Number of c-planes: 2

Lux at center: 625 lx

*Lux distribution on a surface when lamp is mounted at 10 meters from the surface.*

Mounting height: 10 meters (33 feet)



Total lumen output:

10842 lm

Total candela output:

93208 cd

Light quality:

CRI: 97,7

Color temperature:

3245 K

## PRODUCT NAME:

EclipseFresnel TU

## MEASUREMENT CONDITIONS:

Beam angle:

15°

Target:

3200K

Operator:

Paolo Carvone

Date and time:

22/01/2020 14:42:49

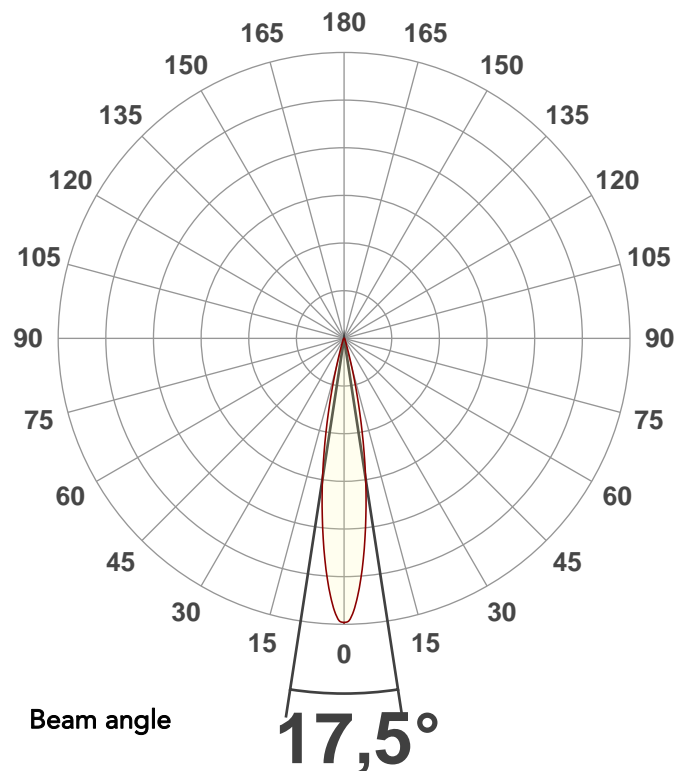

Spectra

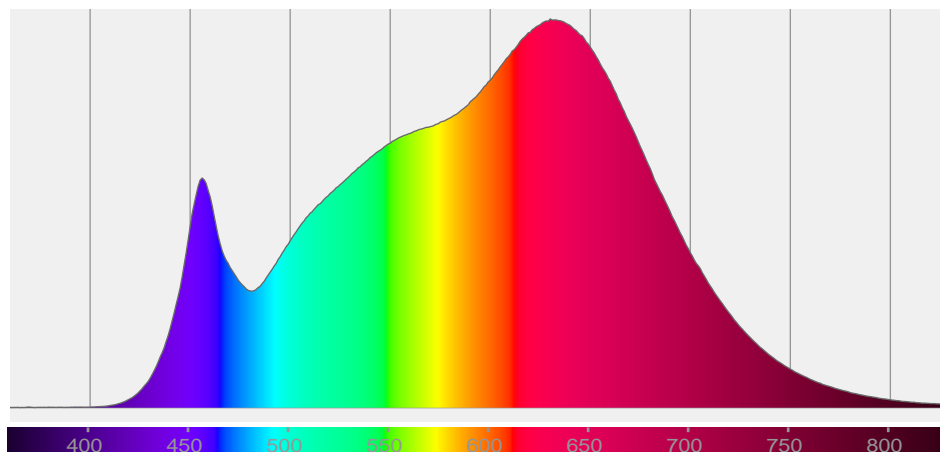

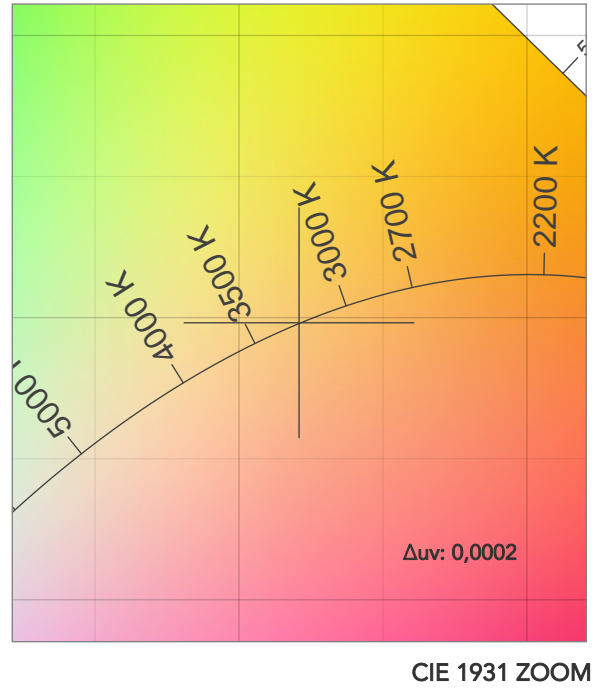
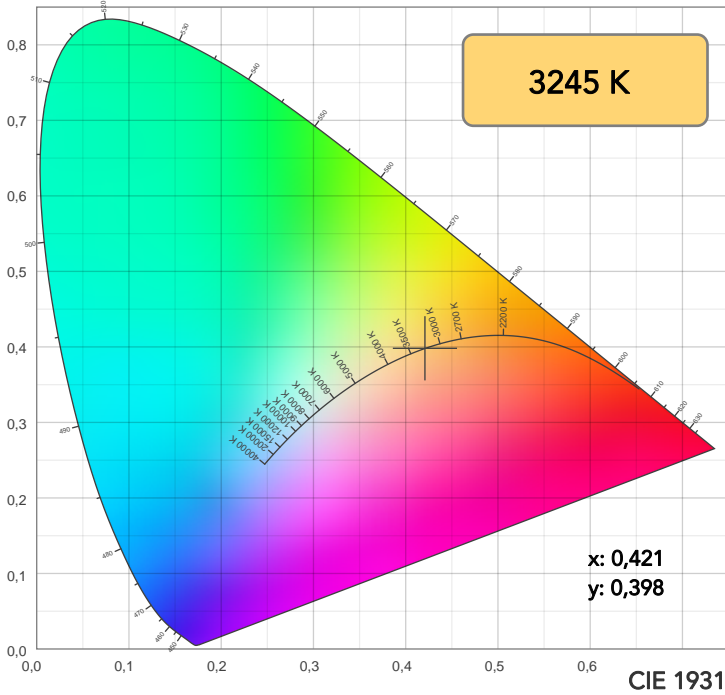

TM30: 92,8

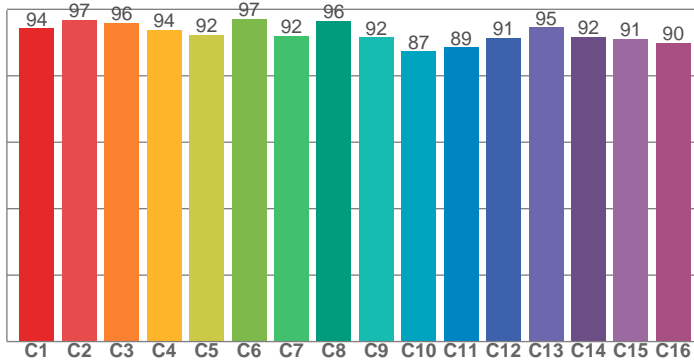

CRI: 97,7 (R1-R8)

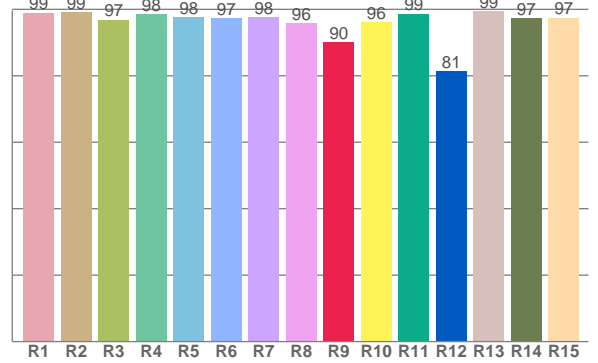

CQS: 95,0

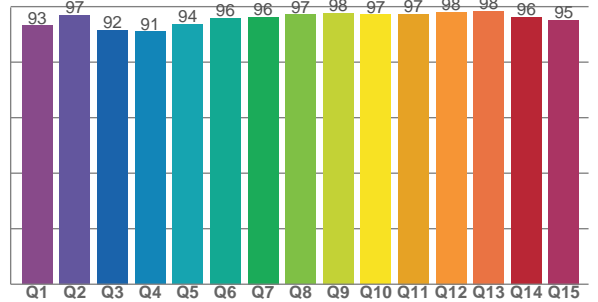

CRI R values, only R1-R8 are used to calculate final CRI value

R1	R2	R3	R4	R5	R6	R7	R8	R9	R10	R11	R12	R13	R14	R15
99,0	99,2	96,8	98,4	97,7	97,3	97,7	95,8	90,1	96,1	98,7	81,4	99,4	97,4	97,5

TM30 C values, 16 binned values out of total of 99 C values

C1	C2	C3	C4	C5	C6	C7	C8	C9	C10	C11	C12	C13	C14	C15	C16
94,2	96,9	96,0	93,8	92,3	97,2	92,0	96,4	91,6	87,4	88,6	91,4	94,6	91,7	91,2	89,9

CQS Q values

Q1	Q2	Q3	Q4	Q5	Q6	Q7	Q8	Q9	Q10	Q11	Q12	Q13	Q14	Q15
93,1	97,0	91,7	91,0	93,6	95,9	96,3	97,1	97,6	97,2	97,3	98,0	98,3	96,1	95,3

COLOR PARAMETERS

Color temperature	Color rendering index	Red component	Color fidelity	Color gamut	Color quality scale	Television lighting index	Color coordinate cie 1931	Color coordinate cie 1931	Color deviation from black body
CCT	CRI	CRI R9	TM30 Rf	TM30 Rg	CQS	TLCI	x	y	Δuv
3245 K	97,7	90,1	92,8	99,6	95,0	98	0,421	0,398	0,0002

# TM30 DETAILS

**Rf 92,8**  
Fidelity index Rf

**Rg 99,6**  
Gammut index

Hue Bin	R <sub>f</sub>	Graphic shifts (%)	
		Chroma	Hue
1	94	-1%	1%
2	97	-1%	0%
3	96	-1%	1%
4	94	-3%	-1%
5	92	-5%	0%
6	97	-1%	1%
7	92	-3%	3%
8	96	-1%	2%
9	92	0%	5%
10	87	1%	7%
11	89	3%	7%
12	91	5%	1%
13	95	1%	-3%
14	92	4%	-4%
15	91	0%	-2%
16	90	1%	-6%

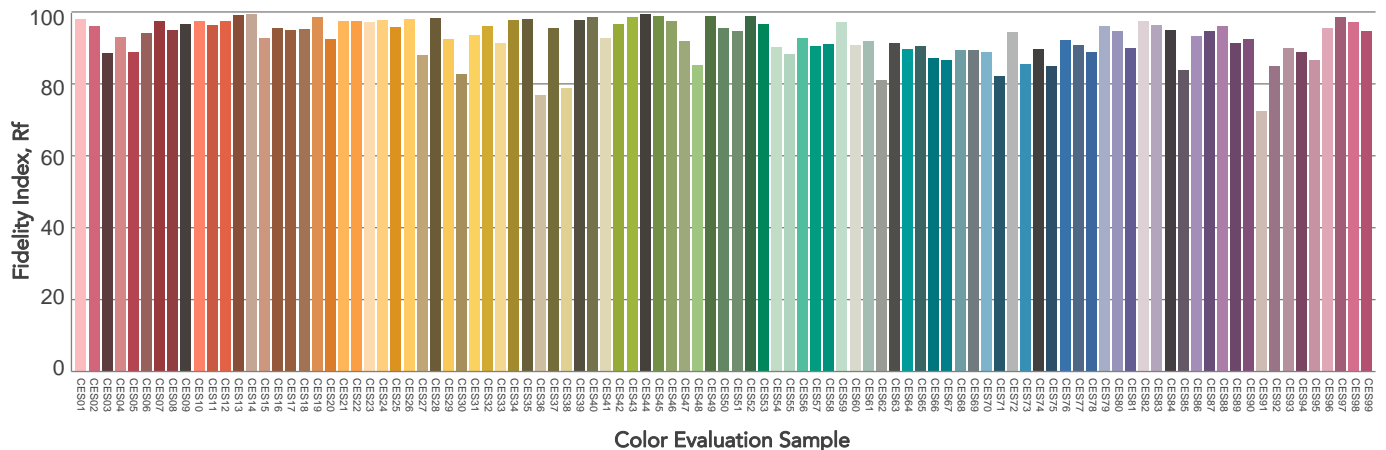
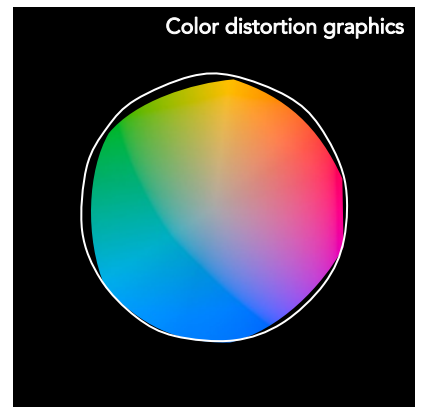
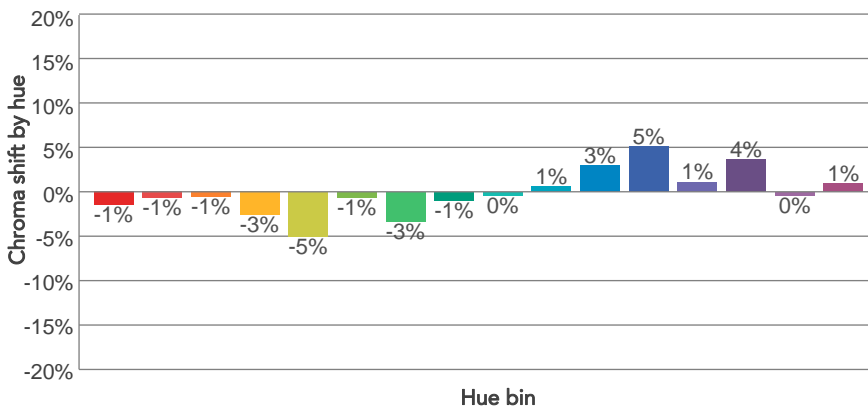
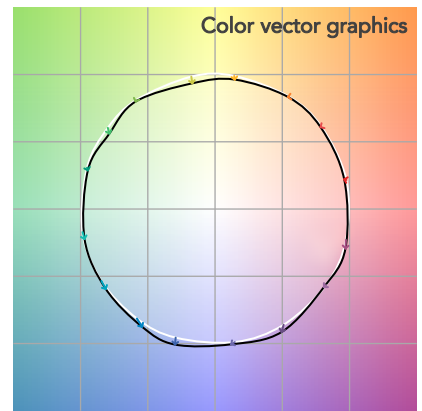
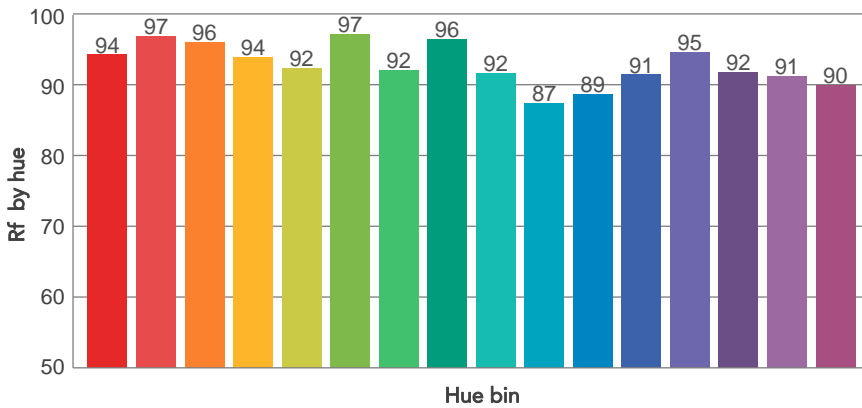
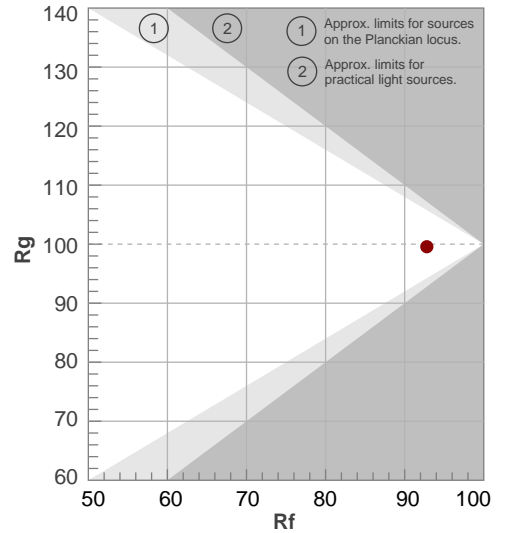

# BEAM DETAILS



Beam angle 50%	Field angle 10%	Cutoff angle 2,5%	Intensity ratio in 120° cone	Intensity ratio in 90° cone
17,5°	30,4°	40,2°	94,3%	92,4%

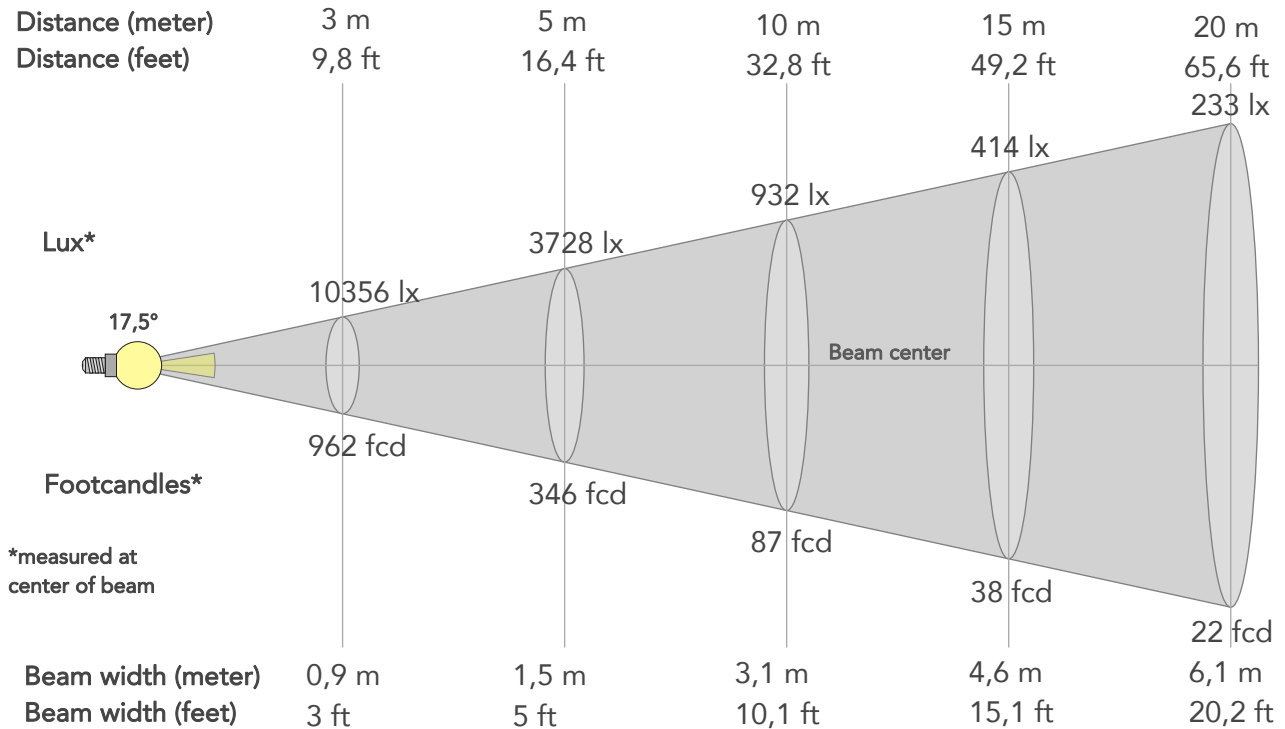

## BEAM INTENSITIES AND WIDTHS

Distance	1m	2m	3m	4m	5m	7,5m	10m	15m	20m	25m	30m	40m	50m
Distance	3,3ft	6,6ft	9,8ft	13,1ft	16,4ft	24,6ft	32,8ft	49,2ft	65,6ft	82ft	98,4ft	131,2ft	164ft
Lux	93208lx	23302lx	10356lx	5825lx	3728lx	1657lx	932lx	414lx	233lx	149lx	104lx	58lx	37lx
Footcand.	8659fcd	2165fcd	962fcd	541fcd	346fcd	154fcd	87fcd	38fcd	22fcd	14fcd	10fcd	5fcd	3fcd
Beam wid.	0,3m	0,6m	0,9m	1,2m	1,5m	2,3m	3,1m	4,6m	6,1m	7,7m	9,2m	12,3m	15,4m
Beam wid.	1ft	2ft	3ft	4ft	5ft	7,6ft	10,1ft	15,1ft	20,2ft	25,2ft	30,2ft	40,3ft	50,4ft

## LINEAR DISTRIBUTION DIAGRAM

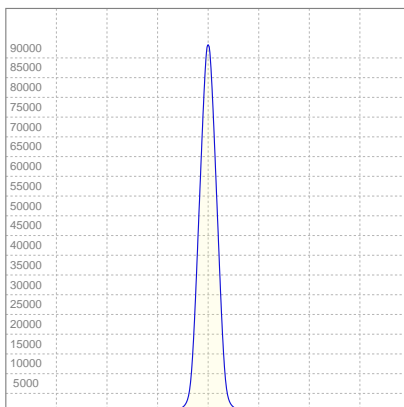

## ELECTRICAL SPECIFICATIONS

Input voltage	Input current	Input power	Effeciency
224V	1,00A	210,1W	52lm/W



## ISO CANDELA DIAGRAM

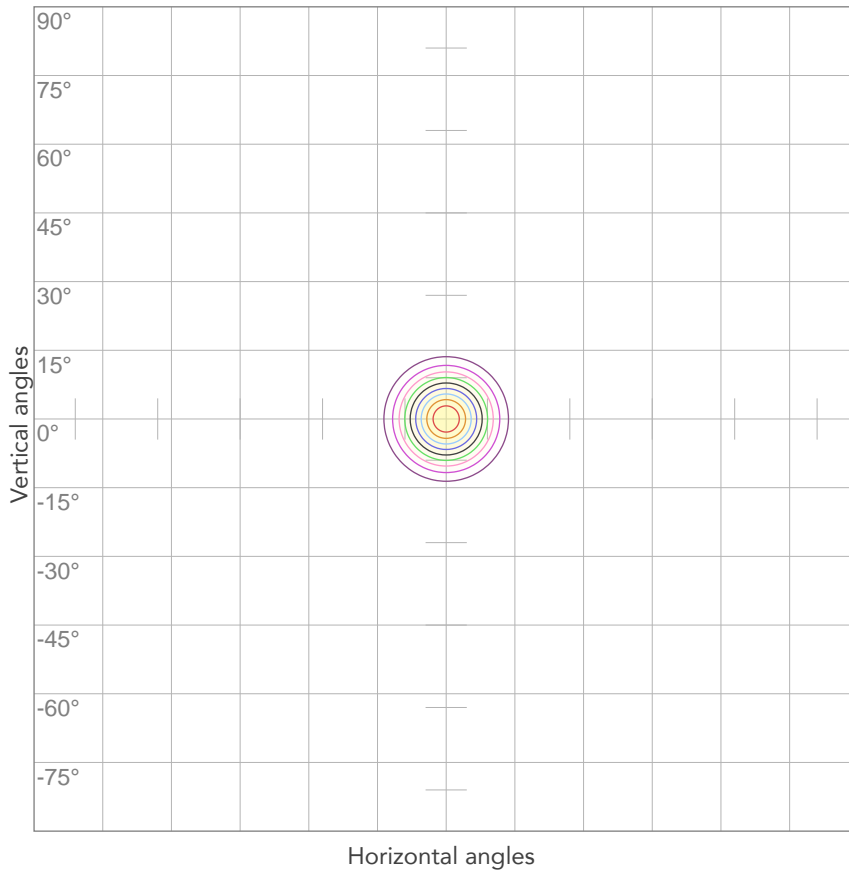

10%	9321 cd
20%	18642 cd
30%	27962 cd
40%	37283 cd
50%	46604 cd
60%	55925 cd
70%	65245 cd
80%	74566 cd

Conditions:

Number of c-planes: 2

Candela at center: 93208 cd

## ISO LUX DIAGRAM

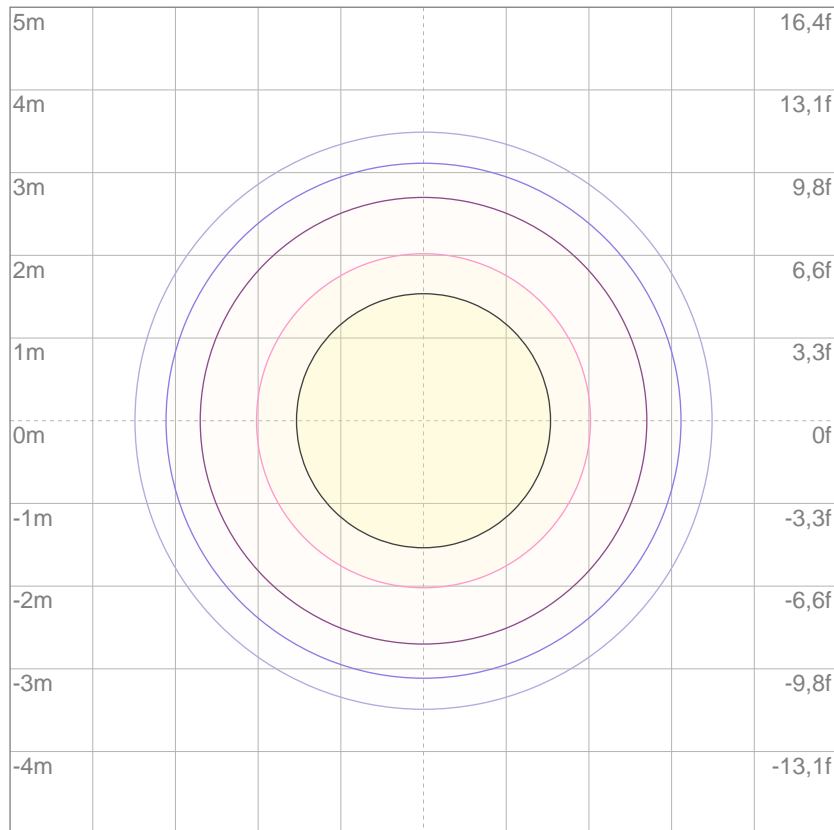

3%	28,0 lx
5%	46,6 lx
10%	93,2 lx
30%	280 lx
50%	466 lx

Conditions:

Number of c-planes: 2

Lux at center: 932 lx

*Lux distribution on a surface when lamp is mounted at 10 meters from the surface.*

Mounting height: 10 meters (33 feet)