

Content**Typ: HQ30**

1. Description
2. Materials
3. Partial factors
4. Profile main tube and bracing
5. Profile Truss
6. Calculation of permissible force in main tube
7. Calculation of permissible force in main tube
8. Design cutting forces
9. Displacement in frame work
10. Load chart for user loads

Apendix Load chart for user loads

1. Description

The structure is a modular truss beam. Elements with different length can be mount to a straight beam.

The profile is a square with 4 main tubes.

The truss is a welded structure of tubes. A drawing has to be attached to this calculation to complete it.

In the calculation the resistance and design cutting forces are determined and a table with permissible user loads is created.

The calculated values are based on the framework theory - so all loads are applied on the knotpoints.

This static calculation is applicable on all straight elements with a bracing of minimum 45° to the horizontal axis on the whole length of the element. For lower angles or missing bracing the calculation is not applicable.

The folling standards have been considered:

DIN EN 1999-1-1 and DIN EN 1999-1-1/A2

This standards are binding according european building authorities.

The necessary manufacturer qualificatin is:
DIN EN 1090 - with EXC 2

Note:

The standard uses "eff" for different values - the calculation separates Zeff,buck" for buckling and "eff" for HAZ reasons.

2. Materials

Aluminium
Welding process WIG
Correction factor 0,8
Welding material 5356

für nachfolgende Werte f_{haz} , ρ

EN AW alloy temper	<u>main tube</u> 6082 T6	<u>bracing</u> 6082 T6	<u>connector</u> 6082 T6	
Strength according Table 3.2b				
t - thickness	$t \leq 5$	$t \leq 5$	$5 < t \leq 15$	mm
$f_o =$	250	250	260	N / mm ²
$f_u =$	290	290	310	N / mm ²
$f_{o,haz} =$	125	125	125	N / mm ²
$f_{u,haz} =$	185	185	185	N / mm ²
HAZ factor according table 3.2b - proper calculated				
$\rho_{o,haz} =$	0,500	0,500	0,481	
$\rho_{u,haz} =$	0,638	0,638	0,597	
Values including factor of footnote 4) table 3.2b				
$f_{o,haz} =$	100	100	100	N / mm ²
$f_{u,haz} =$	148	148	148	N / mm ²
$\rho_{o,haz} =$	0,400	0,400	0,385	N / mm ²
$\rho_{u,haz} =$	0,510	0,510	0,477	N / mm ²
E =	70000 N / mm ²			

3. Partial factors

Selfweight of truss $\gamma_{f1} = 1,35$

User Load $\gamma_{f2} = 1,5$

Resistance $\gamma_{M0} = 1,00$

$\gamma_{M1} = 1,10$

buckling

$\gamma_{M2} = 1,25$

breaking caused by tension

$\gamma_{MP} = 1,25$

$\gamma_{Mw} = 1,25$

4. Profile main tube and bracing

Main tube

d =	50 mm	$\beta =$	12,247
t =	3 mm	$\varepsilon =$	1,000
A =	442,96 mm ²	Material class	A
I =	122811,93 mm ⁴	$\beta / \varepsilon =$	12,247
W =	4912,48 mm ³	CS class	2
i =	16,65 mm	Proof	EL-EL
L _{cr} =	480,00 mm	A _{eff,buck} =	442,96
$\lambda =$	28,827	N _{cr} =	368261,10 N

No transverse welds - no brace connection

$\lambda_0 =$	0,1
$\alpha =$	0,2
$\lambda = (A_{\text{eff,buck}} * f_0 / N_{\text{cr}})^{0,5} =$	0,548
$\phi = 0,5 * (1 + \alpha * (\lambda - \lambda_0) + \lambda^2) =$	0,695
$\chi = 1 / (\phi + (\phi^2 - \lambda^2)^{0,5}) =$	0,891
$\omega_x =$	1 only axial force

With transverse welds - brace connection in one plane

$\lambda_{\text{haz}} = (A_{\text{u,eff}} * f_u / N_{\text{cr}})^{0,5} = (A_g * \rho_{\text{u,haz}} * f_u / N_{\text{cr}})^{0,5} =$	0,422
$\phi_{\text{haz}} = 0,5 * (1 + \alpha * (\lambda_{\text{haz}} - \lambda_0) + \lambda_{\text{haz}}^2) =$	0,621
$\chi_{\text{haz}} = 1 / (\phi_{\text{haz}} + (\phi_{\text{haz}}^2 - \lambda_{\text{haz}}^2)^{0,5}) =$	0,928
$\omega_{\text{x,haz}} =$	1

$\kappa =$ 1 - no longitudinal welds

Bracing vertical

d =	20 mm	$\beta =$	9,487
t =	2 mm	$\varepsilon =$	1,000
A =	113,10 mm ²	Material class	A
I =	4636,99 mm ⁴	$\beta / \varepsilon =$	9,487
W =	463,70 mm ³	CS class	2
i =	6,40 mm	Proof	EL-EL
L _{cr} =	339,00 mm	A _{eff,buck} =	113,10
$\lambda =$	52,94	N _{cr} =	27876,27 N

$\underline{\lambda}_0 =$	0,1
$\alpha =$	0,2
$\underline{\lambda} = (A_{\text{eff,buck}} * f_0 / N_{\text{cr}})^{0,5} =$	1,007
$\phi = 0,5 * (1 + \alpha * (\underline{\lambda} - \underline{\lambda}_0) + \underline{\lambda}^2) =$	1,098
$\chi = 1 / (\phi + (\phi^2 - \underline{\lambda}^2)^{0,5}) =$	0,652
$\omega_x =$	1 only axial force
$\kappa =$	1 no longitudinal welds

Bracing horizontal

d =	20 mm	$\beta =$	9,487
t =	2 mm	$\varepsilon =$	1,000
A =	113,10 mm ²	Material class	A
I =	4636,99 mm ⁴	$\beta / \varepsilon =$	9,487
W =	463,70 mm ³	CS class	2
i =	6,40 mm	Proof	EL-EL
L _{cr} =	339,00 mm	A _{eff,buck} =	113,10
$\lambda =$	52,94	N _{cr} =	27876,27 N

$\underline{\lambda}_0 =$	0,1
$\alpha =$	0,2
$\underline{\lambda} = (A_{\text{eff,buck}} * f_0 / N_{\text{cr}})^{0,5} =$	1,007
$\phi = 0,5 * (1 + \alpha * (\underline{\lambda} - \underline{\lambda}_0) + \underline{\lambda}^2) =$	1,098
$\chi = 1 / (\phi + (\phi^2 - \underline{\lambda}^2)^{0,5}) =$	0,652
$\omega_x =$	1 only axial force
$\kappa =$	1 no longitudinal welds

5. Profile Truss

Axis vertical

$$e_z = 240,00 \text{ mm}$$

Axis horizontal

$$e_y = 240,00 \text{ mm}$$

$$\begin{aligned} A &= 1772 \text{ mm}^2 \\ I_y &= 26006007 \text{ mm}^4 \\ I_z &= 26006007 \text{ mm}^4 \\ W_{y,el} &= 179352 \text{ mm}^3 \\ W_{z,el} &= 179352 \text{ mm}^3 \\ i_y &= 121 \text{ mm} \\ i_z &= 121 \text{ mm} \end{aligned}$$

Scheme of the cross section to calculate the profile values.
Mesasurements can be taken from manufacturers drawing.

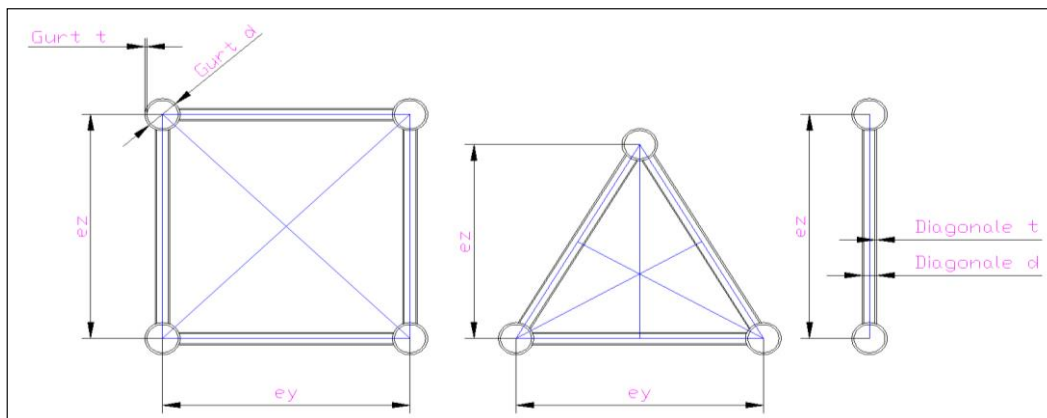

6. Calculation of permissible force in main tube

a. Tension in main tube (according 6.2.3)

General yielding along the member

$$N_{o,Rd} = A_g * f_0 / \gamma_{M1} = 100673,765 \text{ N}$$

Local failure at a section with holes

$$N_{u,Rd} = 0,9 * A_{net} * f_u / \gamma_{M2} =$$

- no holes in tube

Local failure at a section with HAZ

$$N_{u,Rd} = A_{u,eff} * f_u / \gamma_{M2} = A_g * \rho_{u,haz} * f_u / \gamma_{M2} = 52447,004 \text{ N}$$

b. Compression main tube (according 6.2.4 and 6.3.1.1)

Local failure at a section with transverse welds

$$N_{u,Rd} = A_{u,eff} * f_u / \gamma_{M2} = 52447,004 \text{ N}$$

$A_{u,eff}$ is smaller value of:

$A_g * \rho_{u,haz} =$	226,065 mm ²	aufgrund Schweißnaht
$A_{eff,buck} =$	442,965 mm ²	aufgrund örtlichen Beulens bei Q.- Kl.4

Permissible force in main tube due to buckling resistance

$$N_{b,Rd} = \kappa * \chi * \omega_x * A_{eff,buck} * f_0 / \gamma_{M1} = 89687,932 \text{ N} \quad 1)$$

Brace connection in one plane

Arc length total	$L_{ges} =$	157,080 mm
Arc length brace attachment	$L_{VB} =$	20,576 mm
Extent of HAZ		30,000 mm
Arc length HAZ	$L_{WEZ} =$	80,576 mm
Reduced thickness	$t_{eff} = t_g * \rho_{u,haz} =$	1,531 mm
	$A_{u,eff} =$	352,876 mm ²

$$N_{b,Rd} = \chi_{haz} * \omega_{x,haz} * A_{u,eff} * f_u / \gamma_{M2} = 76004,662 \text{ N} \quad 2)$$

1) If there is no transverse bracing on the buckling length = no welding (6.49a)

2) Bracing from one plane = transversal weld (6.49b)

At this design: $\min N_{b,Rd} = 76004,662 \text{ N}$

c. Connection main tube to fitting

$f_w = 210 \text{ N / mm}^2$ Schw.-Zusatz 5356

Circular welding

$\sigma_{f,Rd} = f_w / \gamma_{Mw} = 168 \text{ N / mm}^2$
 $\sigma_{haz,Rd} = f_{u,haz} / \gamma_{Mw} = 118,4 \text{ N / mm}^2$

$t_e = 3 \text{ mm}$ Einbrandtiefe
 $A_w = 442,965 \text{ mm}^2$

Permissible force in main tube due to circular weld

$N_{w,Rd} = A_w * \sigma_{f,Rd} = 74418,047 \text{ N}$

$N_{w,haz,Rd} = A_w * \sigma_{haz,Rd} = 52447,004 \text{ N}$

decisive 52447,004 N

Permissible force in main tube in total due to welds

$N_{w,haz,Rd} = 52447,004 \text{ N}$

d. Conical pin

min. values for strength:

$f_{yp} =$	650,000 N / mm ²	$t_1 =$	10 mm
$f_{up} =$	850,000 N / mm ²	$t_2 =$	27,7 mm
$d =$	10,650 mm	$s =$	1 mm
$A =$	89,082 mm ²		
$W =$	118,590 mm ³		

Cylindric Pin

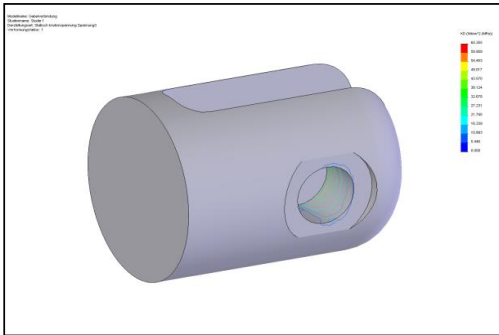

Conical pin

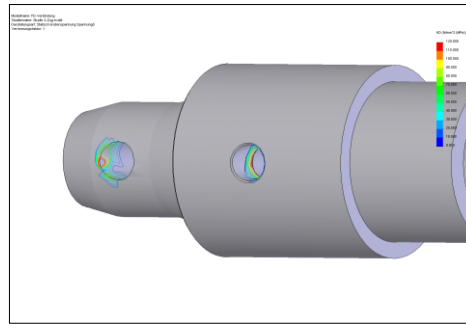

Spreading of the bearing width a_p (Contact pressure FEM)

$a_p = t_1$ total width

$a_p <> 0,5 * t_1$ concentrated

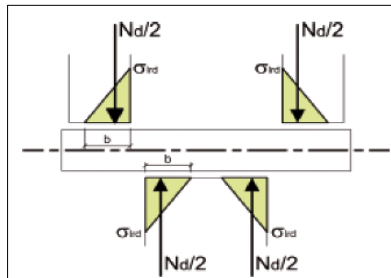

Position of resultant force x_h

$x_h = 1/3 * t_1$

$x_h = 1/3 * 0,5 * t_1$

$h_M = x_h * 2 + s =$	4,333 mm	relevant lever
$a_p =$	5,000 mm	bearing width
maßgebend	right picture	for conical pin

Existing stress

Highest stress of other componentsn:

max $N_{Rd} = 52447,004 \text{ N}$ Tension main tube
Local failure at a section with transv. welds

$F_d = 52447,004 \text{ N}$ will be applied for proof

$$M_d = F_d / 2 * h_M = 113635,2 \text{ Nmm} \quad \text{max}$$

$$F_{v,d} = F_d / 2 = 26223,5 \text{ N} \quad \text{max}$$

$$M_{Rd} = 1,5 * W_{el} * f_{yp} / \gamma_{M0} = 115625,4 \text{ Nmm} \quad \text{not move able}$$

$$F_{v,Rd} = \alpha * A * f_{up} / \gamma_{M2} = 33316,6 \text{ N} \quad \alpha = 0,55$$

$$\text{max} \quad M_d / M_{Rd} = 0,983 < 1$$

$$\text{max} \quad F_{v,d} / F_{v,Rd} = 0,787 < 1$$

Interaction

M_{d1} at position of max $F_{v,d}$ - plane to inside fitting

$$M_{d1} = 1/6 * a_p * F_d + F_d/2 * s = 69929,339 \text{ Nmm}$$

$$(M_{d1} / M_{Rd})^2 + (F_{v,d} / F_{v,Rd})^2 = 0,985 < 1$$

$$\text{max } \eta = 0,985 < 1$$

Permissible force in main tube due to pin

$$N_{Rd} > 52447,004 \text{ N}$$

e. Fitting

$$f_u = 310 \text{ N / mm}^2 \quad \text{outer}$$

$$f_u = 350 \text{ N / mm}^2 \quad \text{inner}$$

	Outer fitting	Inner fitting
Edge distance $e_1 =$	23 mm	17,2 mm
$\alpha_d = e_1 / (3 * d_0) =$	0,720	0,538
$f_{up} / f_u =$	2,742	2,742
$\alpha_b =$	0,720	0,538
$e_2 =$	25 mm	13,85 mm
$k_1 =$	2,5	1,94

$$F_{b,Rd} = 2 * k_1 * \alpha_b * f_u * d * t_1 / \gamma_{M2} = 95066,7 \text{ N} \quad \text{outer}$$

$$F_{b,Rd} = k_1 * \alpha_b * f_u * d * t_2 / \gamma_{M2} = 86325,9 \text{ N} \quad \text{inner}$$

$$\sigma_{L,RD} = F_{b,Rd} / (d * t_1 * 2) = 446,32 \text{ N / mm}^2 \quad \text{outer}$$

$$\sigma_{L,RD} = F_{b,Rd} / (d * t_2) = 292,63 \text{ N / mm}^2 \quad \text{inner}$$

Permissible force in main tube due to bearing in fitting

$$F_{b,Rd} = 86325,858 \text{ N}$$

f. Spigot

$d_K =$	27,700 mm	
$r_k =$	13,85 mm	
$A_k =$	6,026 cm ²	without hole
$d_B =$	10,650 mm	
$h_{Seg} =$	8,525 mm	Thickness each segment
$A_{net} =$	315,062 mm ²	
$f_u =$	350 N / mm ²	

Permissible force in main tube due to spigot failure

$$N_{u,Rd} = 0,9 * A_{net} * f_u / \gamma_{M2} = 88217,231 \text{ N}$$

7. Calculation of permissible force in main tube

a. Buckling

Vertical

$$d = 20,000 \text{ mm}$$

$$t = 2,000 \text{ mm}$$

$$A = 1,131 \text{ cm}^2$$

Permissible force in brace due to buckling

$$N_{b,Rd} = \kappa * \chi * \omega_x * A_{\text{eff,buck}} * f_0 / \gamma_{M1} = 16746,500 \text{ N}$$

Horizontal

$$d = 20,000 \text{ mm}$$

$$t = 2,000 \text{ mm}$$

$$A = 1,131 \text{ cm}^2$$

Permissible force in brace due to buckling

$$N_{b,Rd} = \kappa * \chi * \omega_x * A_{\text{eff,buck}} * f_0 / \gamma_{M1} = 16746,500 \text{ N}$$

b. Welding

Vertical

$$f_w = 210 \text{ N / mm}^2 \quad \text{Welding mat.} \quad 5356$$

Circular weld

$$\sigma_{T,Rd} = f_w / \gamma_{Mw} = 168 \text{ N / mm}^2$$

$$\sigma_{haz,Rd} = f_{u,haz} / \gamma_{Mw} = 118,4 \text{ N / mm}^2$$

$$\alpha = 45^\circ \quad \text{to length axis}$$

$$\eta = 0,9 \quad \text{circular around bracing}$$

$$L_w = 68,26 \text{ mm}$$

$$a_w = 2,00 \text{ mm}$$

$$A_w = 136,52 \text{ mm}^2$$

Permissible force in brace due to welding

$$N_{w,Rd} = A_w * \sigma_{T,Rd} = 22935,454 \text{ N}$$

$$N_{w,haz,Rd} = A_w * \sigma_{haz,Rd} = 16164,034 \text{ N}$$

decisive 16164,034 N

Horizontal

$$f_w = 210 \text{ N / mm}^2 \quad \text{Welding mat.} \quad 5356$$

Circular weld

$$\sigma_{T,Rd} = f_w / \gamma_{Mw} = 168 \text{ N / mm}^2$$

$$\sigma_{haz,Rd} = f_{u,haz} / \gamma_{Mw} = 118,4 \text{ N / mm}^2$$

$$\alpha = 45^\circ \quad \text{to length axis}$$

$$\eta = 0,9 \quad \text{circular around bracing}$$

$$L_w = 68,26 \text{ mm}$$

$$a_w = 2,00 \text{ mm}$$

$$A_w = 136,52 \text{ mm}^2$$

Permissible force in brace due to welding

$$N_{w,Rd} = A_w * \sigma_{T,Rd} = 22935,454 \text{ N}$$

$$N_{w,haz,Rd} = A_w * \sigma_{haz,Rd} = 16164,034 \text{ N}$$

decisive 16164,034 N

c. HAZ

Vertical

General yielding along the member

$$N_{o,Rd} = A_{dia} * f_0 / \gamma_{M1} = 25703,940 \text{ N}$$

Local failure at a section with HAZ

$$N_{u,Rd} = A_{dia} * \rho_{u,haz} * f_u / \gamma_{M2} = 13390,725 \text{ N}$$

decisive 13390,725 N

Horizontal

General yielding along the member

$$N_{o,Rd} = A_{dia} * f_0 / \gamma_{M1} = 25703,940 \text{ N}$$

Local failure at a section with HAZ

$$N_{u,Rd} = A_{dia} * \rho_{u,haz} * f_u / \gamma_{M2} = 13390,725 \text{ N}$$

decisive 13390,725 N

8. Design cutting forces

Decisive main tube

$$N_{Rd} = 52447,004 \text{ N}$$

Tension main tube

by

Local failure at a section with transv. welds

Decisive brace vertical

$$N_{Rd} = 13390,725 \text{ N}$$

Decisive brace horizontal

$$N_{Rd} = 13390,725 \text{ N}$$

Design values of resistance $M_{y,Rd}$ of truss

(without interaction)

$$M_{y,Rd} = 25,175 \text{ kNm}$$

Design values of resistance $M_{z,Rd}$ of truss

(without interaction)

$$M_{z,Rd} = 25,175 \text{ kNm}$$

Design values of resistance $V_{z,Rd}$ of truss

(without interaction)

$$V_{z,Rd} = 18,937 \text{ kN}$$

Design values of resistance $V_{y,Rd}$ of truss

(without interaction)

$$V_{y,Rd} = 18,937 \text{ kN}$$

9. Displacement in frame work

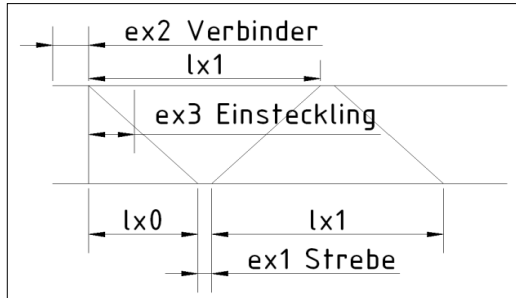

Without endbrace: $l_{x0} = l_{x1}$

Displacement bracing

$$\begin{aligned} e_{x1} &= 27,50 \text{ mm} \\ l_{x1} &= 480 \text{ mm} \\ l_{x0} &= 240 \text{ mm} \end{aligned}$$

Local bending in main tube

$$V_{z, \text{Ebene}} = V_z \times 0,5 \quad \text{for 4-point truss}$$

$$M_{\text{lokal}} = V_{z, \text{Ebene}} \cdot e_{x1} / (e_{x1} + l_{x0} + l_{x1}) \cdot l_{x1} = 0,883 \times V_z \text{ (cm} \cdot \text{kN)}$$

$$\sigma_{(\text{Mlokal})} = M_{\text{lokal}} / W$$

Globale Spannung im Gurt aus N

$$\sigma_{(\text{Nglobal})} = N / A$$

Gesamt

$$\sigma_{d(\text{gesamt})} = \sigma_{(\text{Mlokal})} + \sigma_{(\text{Nglobal})} < \sigma_{Rd}$$

Displacement at connection

$$\begin{aligned} e_{x2} &= 61,00 \text{ mm} \\ e_{x3} &= 15 \text{ mm} \end{aligned}$$

Local bending in main tube

The truss is designed with end braces - load distribution on upper and lower chords

$$V_{z, \text{Gurt}} = V_{z, \text{Ebene}} \times 0,5$$

$$\max M_{\text{lokal}} = V_{z, \text{Gurt}} \cdot e_{x2} = 1,525 \times V_z \text{ (cm} \cdot \text{kN)}$$

Influence of plugged connector

$$M_{\text{lokal}(x)} = \max M_{\text{lokal}} \cdot (l_{x1} - e_{x3}) / l_{x1} = 1,477 \times V_z \text{ (cm} \cdot \text{kN)}$$

$$\sigma_{(\text{Mlokal}(x))} = M_{\text{lokal}(x)} / W$$

Displacement connection is decisive!

Reduced cross section at end brace
from CAD

$$A_{u,eff} = 277,40 \text{ mm}^2$$

$$I_{u,eff} = 74558,70 \text{ mm}^4$$

$$W_{u,eff} = 2681,97 \text{ mm}^3$$

$$N_{u,Rd} = A_{u,eff} * f_u / \gamma_{M2} = 64356,8 \text{ N}$$

$$M_{u,Rd} = W_{u,eff} * f_u / \gamma_{M2} = 622216,49 \text{ Nmm}$$

Proof

$$((N_{Ed} / N_{u,Rd})^{1,3} + (M_{Ed} / M_{u,Rd})^{1,7})^{0,6} < = 1$$

Due to the interaction the load chart is determined. The loads are determined manually to reach not more than 100% utilization.

Reduced cross section at circular welding

with 100% HAS - only for information, because this area is reinforced by the plugged connector.

$$t_{eff} = t_g * \rho_{u,haz} = 1,5310345 \text{ mm}$$

$$\Delta t = t_g - t_{eff} = 1,4689655 \text{ mm}$$

$$d_{a,eff} = 48,531034 \text{ mm}$$

$$d_{i,eff} = 45,468966 \text{ mm}$$

$$A_{u,eff} = 226,06467 \text{ mm}^2 = A_g * \rho_{u,haz}$$

$$I_{u,eff} = 62488,347 \text{ mm}^4$$

$$W_{u,eff} = 2575,1912 \text{ mm}^3$$

$$N_{u,Rd} = A_{u,eff} * f_u / \gamma_{M2} = 52447,004 \text{ N}$$

$$M_{u,Rd} = W_{u,eff} * f_u / \gamma_{M2} = 597444,36 \text{ Nmm}$$

10. Load chart for user loads

The user loads cause a 100% maximum to the design resistance values.
The interaction of local bending is considered.

The chart is useable for a simple beam with joint supports.
The loads are applied on the knot points.
Local bending caused by displaced loads is not considered.

Deflections are calculated with endless shear stiffness between upper and lower chords. In reality smaller variance is possible (Bernoulli / Timoschenkow).

Considered selfweight:

$$g = 0,074 \text{ kN / m}$$