

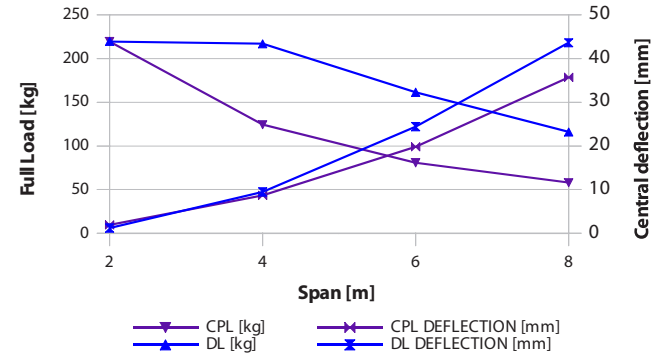

SF22

Flat section aluminium truss with 22cm long sides

- Lengthwise: extruded tubes, Ø 35x1,5 mm 6082 T6
- Diagonal: extruded tubes, Ø 8mm 6082 T6
- Plate: conical quick-lock connectors
- Fast connection kit FCF3 included

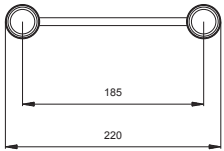
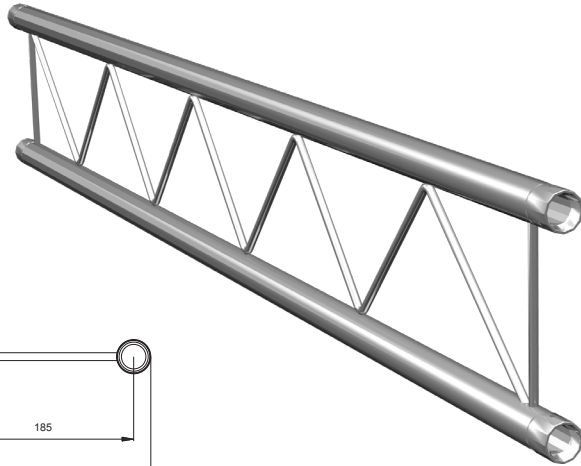

Distributed Load

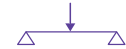

Centre Point Load

SPAN [m]	Distributed Load			Centre Point Load	
	Point load [kg/m]	Full load [kg]	Central deflection [mm]	Full load [kg]	Central deflection [mm]
2	109.8	219.6	1.2	219.5	1.9
4	54.2	216.8	9.5	124.3	8.7
6	26.9	161.4	24.4	80.6	19.8
8	14.5	116	43.6	58	35.7

Variants

Code	Tube (mm)	Diagonal (mm)	W (cm)	H (cm)	D (cm)	Weight (kg)	Volume (mc)
SF22050	35x1.5	8	50	3,5	22	0.6	0.004
SF22100	35x1.5	8	100	3,5	22	1.2	0.008
SF22150	35x1.5	8	150	3,5	22	1.8	0.012
SF22200	35x1.5	8	200	3,5	22	2.3	0.015
SF22250	35x1.5	8	250	3,5	22	2.7	0.019
SF22300	35x1.5	8	300	3,5	22	3.3	0.023
SF22350	35x1.5	8	350	3,5	22	3.9	0.027
SF22400	35x1.5	8	400	3,5	22	4.5	0.031



Included

FCF3

Quick connection, 2 spigots, 4 pins, 4 safety spring, SF22

Optional accessories

SF22FP

Aluminium ground base for flat section trusses, SF22





Joints

Variants

Code	Type	Way (nr)	Angle	Orient.	Vertex	W (cm)	H (cm)	D (cm)
SF22L2045H	L2	2	45°	horiz.	-	50	3,5	50
SF22L2045V	L2	2	45°	vertical	-	50	22	50
SF22L2060H	L2	2	60°	horiz.	-	50	3,5	50
SF22L2060V	L2	2	60°	vertical	-	50	22	50
SF22L2090V	L2	2	90°	vertical	-	50	22	50
SF22L2090H	L2	2	90°	horiz.	-	50	3,5	50
SF22L2045H	L2	2	45°	horiz.	-	50	3,5	50
SF22L2045V	L2	2	45°	vertical	-	50	22	50
SF22L2060H	L2	2	60°	horiz.	-	50	3,5	50
SF22L2060V	L2	2	60°	vertical	-	50	22	50
SF22L3H	L3	3	90°	horiz.	-	50	50	50
SF22L3V	L3	3	90°	vertical	-	50	50	50
SF22T3H	T3	3	90°	horiz.	-	50	3,5	50
SF22T3V	T3	3	90°	vertical	-	50	50	50
SF22X4V	X4	4	90°	vertical	-	50	22	50
SF22X4H	X4	4	90°	horiz.	-	50	3,5	50
SF22T4H	T4	4	90°	horiz.	-	50	50	50
SF22T4V	T4	4	90°	vertical	-	50	50	50
SF22LX4H	LX4	4	90°	horiz.	-	50	50	50
SF22LX4V	LX4	4	90°	vertical	-	50	50	50

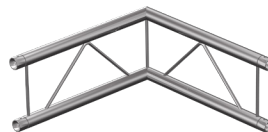

SF22L2045V



SF22L3V



SF22T3V



SF22X4V



SF22T4V



SF22LX4V

Circular Trusses

Variants

Code	Orient.	Vertex	D.Ext (cm)	D.Int. (cm)	H (cm)	D (cm)	Weight (kg)	Arch num
SF22C150V	vertical	-	150	143	22	3,5	6.50	4
SF22C200V	vertical	-	200	193	22	3,5	8.70	4
SF22C300V	vertical	-	300	293	22	3,5	13.10	4
SF22C200H	horiz.	-	200	156	3,5	22	7.90	4
SF22C300H	horiz.	-	300	256	3,5	22	12.30	4

Orientation



VERTICAL



HORIZONTAL

Flat section circular aluminium truss structure with 22cm sides

- Lengthwise: extruded tubes, Ø 50x2 mm 6082 T6
- Diagonal: extruded tubes, Ø 25x2 mm 6082 T6
- Plate: conical quick-lock connectors
- x4 Fast connection kit FCF3 included