



Operating Manual

A 5131 Priority Mixer



Description

This four channel mixer features 4 balanced mic inputs and 3 line inputs. Input 1 is a dedicated balanced mic input whilst inputs 2 - 4 can accept either balanced mic or line level.

Priorities

3 modes of priority are selectable via the DIP switches on the rear:

Cascade: Input 1 overrides 2-4, Input 2 overrides 3-4, Input 3 overrides 4.

FIBD: First In Best Dressed - Regardless of which input is being used, it automatically blocks out all other inputs.

Mixed: No priority therefore all inputs will be mixed as per a normal mixer.

Muting

The system can be configured for PTT muting which operates only with microphone inputs, or VOX muting which operates with both microphone and line inputs. This function is switch selectable via the rear panel DIP switches. (See DIP Switch settings).

Phantom Power

Each microphone input has the option for phantom power (+12V DC). The phantom power is activated for all microphone inputs via jumper JP5 located inside the unit. (Refer to Fig 2).

System Busy

Euro block terminals are included for remote LED indication that the system is busy. For the input in use the LED is in a steady illuminated state. For all other inputs the LED's flash indicating the system is busy and in use. The corresponding LED on the front panel also illuminates indicating the active channel.

The LED's operate both with microphone and auxiliary input signals with either the PTT or VOX muting options selected. The remote busy indicator voltage can be selected internally to 1.5V DC for driving LED's direct, or 12V DC for driving incandescent lamps.

VOX sensitivity

The sensitivity of the VOX circuit can be adjusted via the trimpots located on the front of the unit. Each input has its own dedicated adjustment trimpot. If the Vox circuit needs to be turned off for a particular input, turn the corresponding trimpot fully anti-clockwise.

Features

- 4 balanced microphone / 3 line inputs
- 3 modes of priority Cascade, FIBD, Mixed
- Channel active indicators
- VOX muting or both mic and line inputs
- Adjustable VOX sensitivity for each input
- Separate volume for each input
- VOX or PTT muting
- 24V DC operation
- 24V DC plugpack included

Front Panel Controls

Each input is equipped with a volume control and channel active LED indicator. LED's are provided to indicate power, mode of priority ie Cascade, FIBD, or Mixed plus the type of muting. i.e. PTT or VOX.

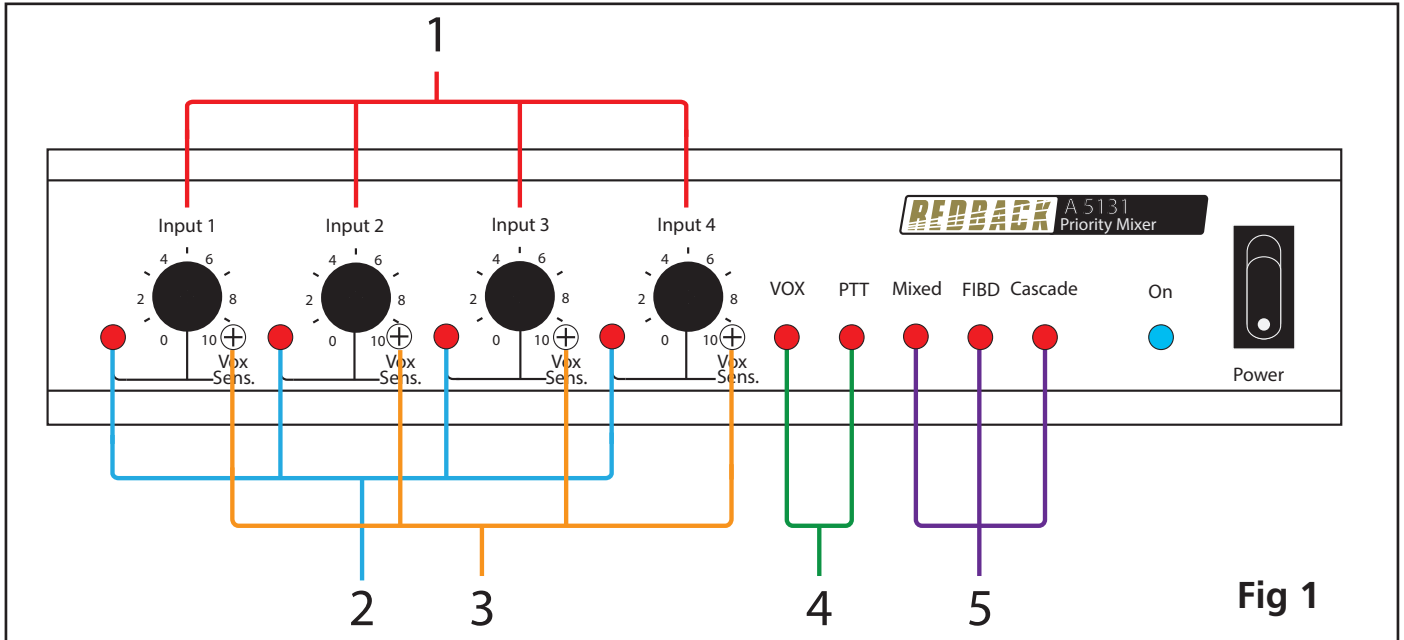

Fig 1

- 1 Volume Controls**
Each input has its own dedicated volume control.
- 2 Input Active LED**
These LED's indicate which input is currently active, with a steady indication. All other input LED's flash to indicate the system is busy.
- 3 VOX sensitivity controls**
Each input has its own VOX sensitivity adjustment trimpot.
- 4 VOX/PTT Indicators**
These LED's indicate if the unit has VOX or PTT muting active. Selectable via DIP Switches (Refer DIP SW settings).
- 5 Priority Indicators**
These LED's indicate which priority mode the unit is running in, if muting has been enabled via DIP switch 1.

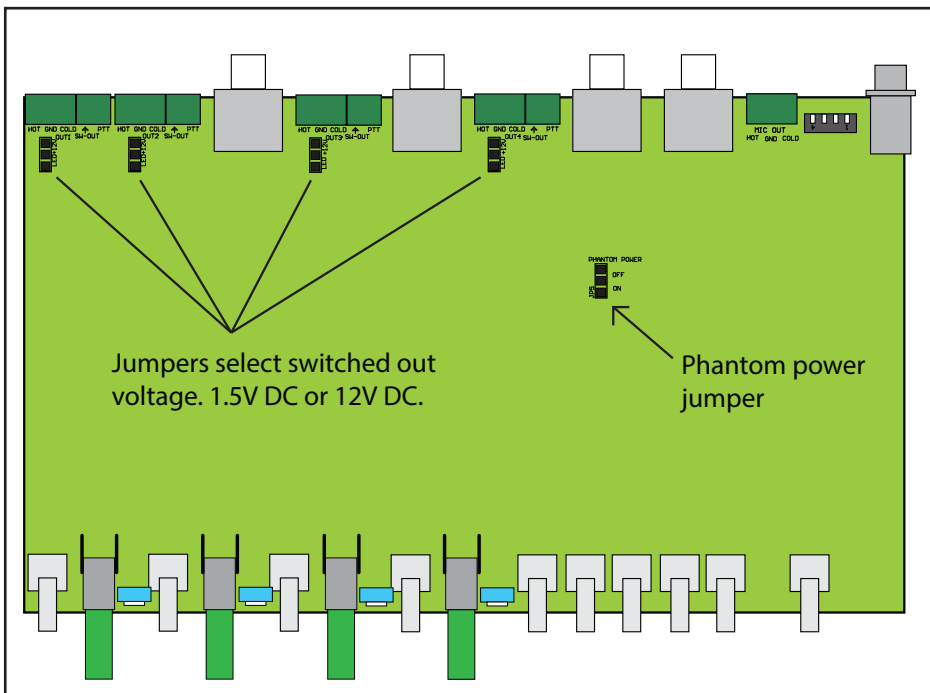

Fig 2

Internal Jumper Settings

Phantom Power

Jumper JP5 is used to activate phantom power. Once activated 12V DC will be provided to the hot and cold terminals of all four of the microphone input connectors.

System Busy - Switched Out Voltage

Each channel has a corresponding 'switched out' set of terminals which can be used for remote monitoring. The voltage output on these terminals can be set to either 1.5V DC for direct driving of an indicator LED or 12V DC for driving incandescent lamps. A set of jumpers has been provided for each output.

Inputs and Outputs

Microphone connections are via 5 way pluggable euro block and line connections are via stereo RCA sockets (converted to mono internally). Two outputs are provided, one for balanced output (level selectable 3mV or 1V via the rear panel DIP switches) and one for line level.

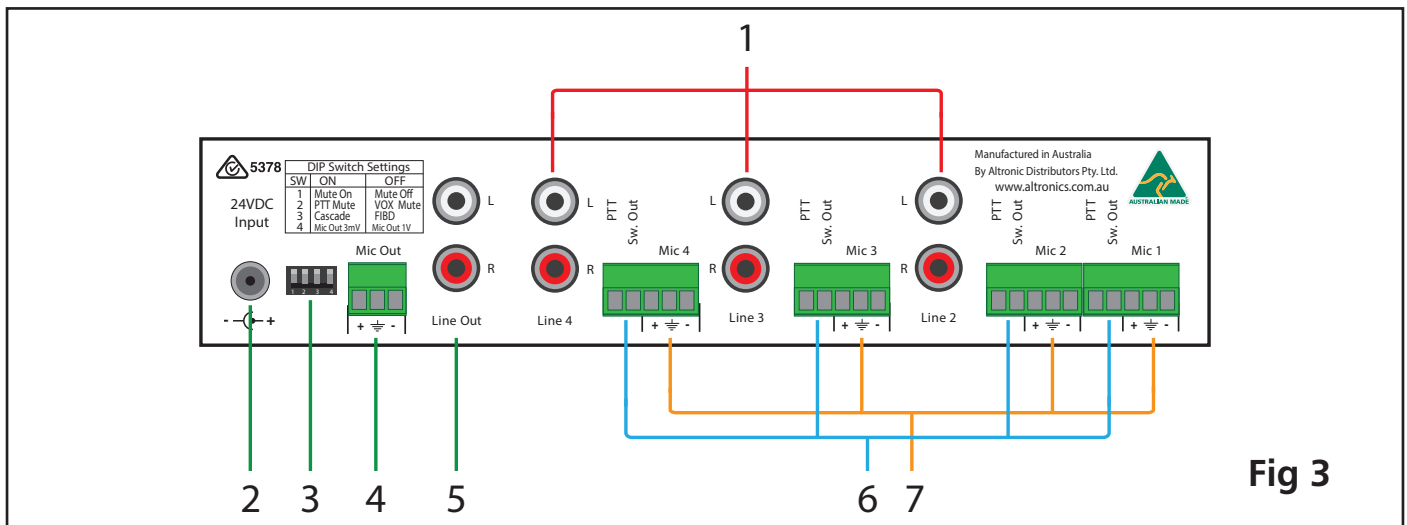

Fig 3

1 Line Level Inputs

Auxiliary RCA inputs are available on channels 2,3 and 4. These are nominal 1V inputs which are internally mixed to become a mono signal.

2 DC Input

Power is supplied to the unit via a 2.1mm (tip to positive) DC socket. The input voltage must be between 24-28V DC.

3 DIP Switches

These switches configure the priority mode, muting options and the mic output sensitivity. (Refer to DIP Switch settings for more detail).

4 Mic Output

This is a balanced microphone output with adjustable level of 3mV or 1V.

5 RCA Stereo Line Output

A line level output of 1V (Note: Left and right channels carry the same output signal. This is not stereo output).

6 PTT and Switched Out

Connects via Euroblock screw terminals. The switched output terminal can be used for remote monitoring, and becomes active when the corresponding input is active. The output can be set to 1.5V DC or 12V DC for driving LED's or Incandescent lamps.

The PTT terminal is for use with microphones with the PTT (Push To Talk) option.

7 Mic In

Euro block screw terminals are provided for the microphone inputs. These are a balanced input with a hot, cold and gnd connection. Connection can be made using screened cable such as the Altronics w 3032.

Cable Requirements

Connection details for balanced microphone inputs with PTT switch and busy LED indicator.

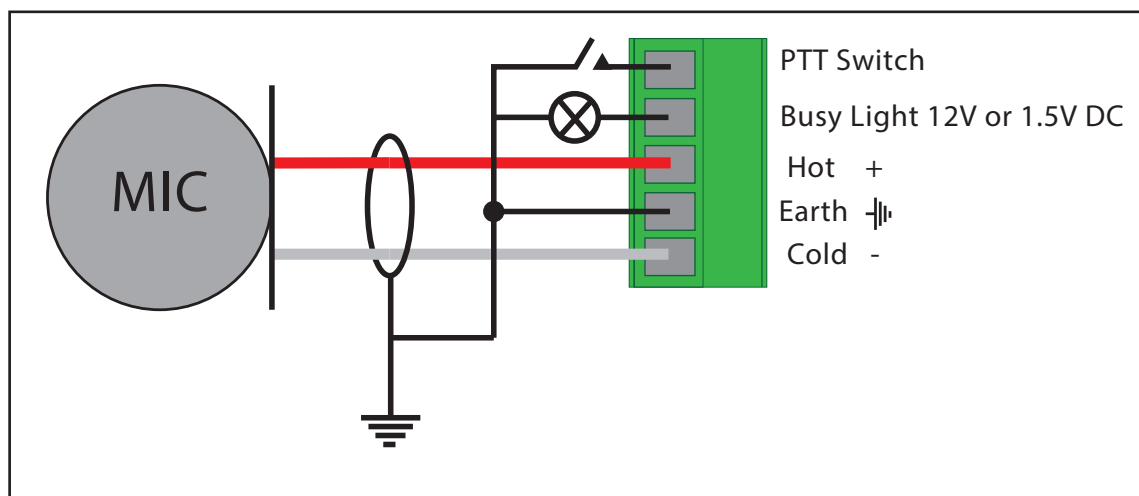

Fig 4

DIP Switch settings

The DIP switches on the rear of the unit configure the Priority mode, muting options and the Mic output sensitivity.

Switch 1 is set ON to enable muting and OFF to disable muting

Switch 2 is set ON to enable PTT muting and OFF to enable VOX muting

Switch 3 is set ON to enable Cascade priority and OFF to enable FIBD priority

Switch 4 is set ON to set the Mic Output Sensitivity to 3mV and OFF to set the Mic Output Sensitivity to 1V

Troubleshooting

NO Power (Power LED does not illuminate):

Check power supply DC jack is 2.1mm and not 2.5mm size.

Power supply voltage is 24-28VDC.

Power supply is a DC output, not AC.