



Operating Manual



User manual revision number: 1.0 04/11/2020

INTRODUCTION:

The Redback® Q 2012 Field strength Meter is absolutely essential for all installers setting up and commissioning hearing induction loop amplifier systems. It is ideally used in conjunction with the Redback® Q 2014 1kHz tone generator allowing an installer to test the signal generated in the actual 'loop' of the system. The resultant signal is 'induced' into the pickup of the Q 2012 tester and the strength of the signal is displayed on the LED display.

It is also ideal for measuring any electrical noise that may be present within the loop precinct, which should be done prior to the loop installation.

The signal strength and quality can also be monitored via headphones, which can be plugged directly into the Q 2012.

The meter has an internal Li-Ion battery which is recharged via a 5V Dc source such as a USB connection.

OPERATION:

Use the "Power" switch to turn the Redback® Q 2012 ON or OFF.

The Q 2012 is also equipped with an auto power off function. The unit will automatically power down after a period of about four minutes, saving precious battery life.

There are two modes of operation available, Field Strength and Background Noise, which are selected by the switch on the end of the Q 2012.

Testing The Field Strength:

Use this mode to determine the db levels of the active loop.

The field Strength is tested to Australian Standard AS60118.4 (2007), using a 1kHz sinusoidal input, with a variation of +/- 3dB. An extract of the standard is supplied on the next page.

In practical terms, the recommended field strength should be 100mAmps/metre with a long term average >60 secs. i.e. -12dB ref 400mA/m (rms). This is the "Field Strength Average" which is shown as the -12dB point on the LED scale on the front of the Q 2012. This is the average reading which needs to be achieved in the listening area.

The recommended field strength maximum should be 400mAmps/metre for 0.125secs. This becomes the 0dB reference. The "Field Strength Maximum" is shown as the 0dB point on the LED scale on the front of the Q 2012. The Field Strength in the listening area should not exceed this 0dB level.

When testing the Field Strength, we recommend connecting the Redback® Q 2014 Audio Generator which has a 1kHz sinusoidal output, to the input of the loop amplifier (as shown in figure 1). The output level of the amplifier is then adjusted to achieve the "Field Strength Average" as measured by the Redback® Q 2012 Field Strength meter.

(Note: When measuring the Field Strength, the Q 2012 should be held vertical for best results).

Redback® Q 2012 Field Strength Meter

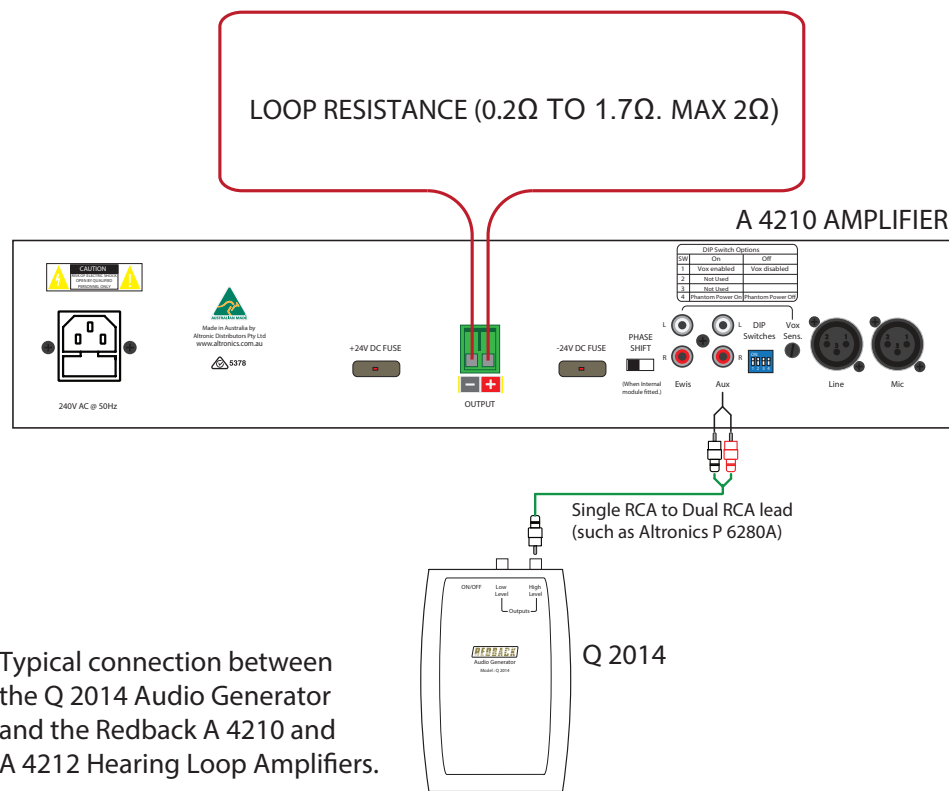

Typical connection between the Q 2014 Audio Generator and the Redback A 4210 and A 4212 Hearing Loop Amplifiers.

Fig 1

Testing The Background Noise:

Use this mode to determine the db levels of background noise, in and around the area the loop is to be installed. The loop must be inactive when testing in this mode.

Measure the environmental background electromagnetic noise with the loop system off.

The required figure is -32dB (re 400mA/m), but ideally a preferred figure is -47dB! A level of -22dB is useable but must be reported.

HEADPHONE SOCKET

The audio from the loop being tested, can be monitored by connecting a set of headphones to the 3.5mm socket on the end of the Q 2012. The Volume knob will adjust the level to the headphones.

BATTERY CHARGING

The "LOW BATTERY" LED will illuminate when the battery requires recharging.

To recharge the internal battery, connect the supplied USB lead to a 5VDC USB source, and connect the other end to the charging socket located on the end of the Q 2012. The blue "CHARGING" LED will illuminate when the unit is charging. When the battery is charged, the unit will stop charging and the LED will turn off. The charger can then be unplugged. The inbuilt charging circuit is a slow charger and may take up to 12 hours to charge a completely flat battery.

REPLACEMENT PARTS

The Redback® Q 2012 Field Strength Meter is supplied with a charging lead. If replacements or spares are required they are available from Altronics (www.altronics.com.au). The part number is P 6703 - USB Type A Male to 1.35mm DC Plug lead.

Extract from AS60118.4 (2007)

"Magnetic Field Strength in Audio-Frequency Induction Loops for Hearing Aid Purposes": The rigorous standard for Audio Induction Loop Systems, making Australia internationally compliant in regard to field strength and audio quality for the hearing impaired. This defines the performance criteria of an induction loop system. The key elements may be summarised:

- Field Strength in the specified listening area shall be -20dB re 1A/m average i.e. 100mA/metre long term average, using a 1kHz sinusoidal input, with a variation of +/-3dB.
- short term peaks up to 400mA/metre (0.125secs integration time)
- Environmental Magnetic Background noise shall be no higher than -40dB A-weighted (measured with the loop system off).
- Frequency Response of the system shall be from 100Hz to 5000Hz. The variation should be no more than +/-3dB from the value taken at 1kHz.

The international standard is IEC 60118.4 (also known as SN, EN or BS 60118.4)