

Ringskrue DIN 580 C15

Produkt info/
Bruksområder:

Elforsinket for bruk i service class 1, innendørs (ikke sertifisert) og varmforsinket service class 3 (med sertifikat).

For oppheng sammen med slaganker eller andre typer av anker med innvendig gjenge.



Materiale

Kvalitet:	Elforsinket eller varmforsinket
DIN standard:	DIN580
Korrosivitets klass:	Service class 1 eller 3

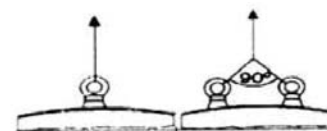
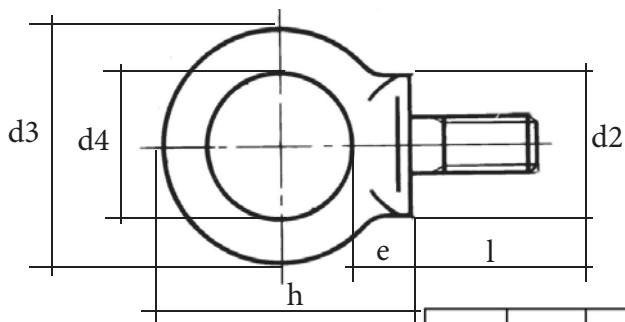

d1	d2	d3	d4	e	h	l	Tillatt * strekklast kg	Tillatt strekklast kg
M8	20	36	20	8,5	36	13	140	95
M10	25	45	25	10	45	17	230	170
M12	30	54	30	11	53	20,5	340	240
M16	35	63	35	13	62	27	700	500
M20	40	72	40	16	71	30	1200	830
M24	50	90	50	20	90	36	1800	1270
M30	65	108	60	25	109	45	3600	2600
M36	75	126	70	30	128	54	5100	3700
M42	85	144	80	35	147	63	7000	5000
M48	100	166	90	40	168	68	8600	6100
M56	110	184	100	45	187	78	11500	8300
M64	120	206	110	50	208	90	16000	11000
M72	150	260	140	60	260	100	21000	15000
M80	170	296	160	70	298	112	28000	20000
M100	190	330	180	80	330	130	38000	27000

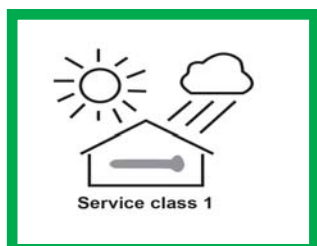

Elforsinket uten setrifikat

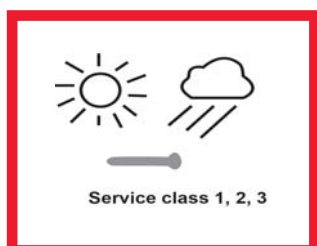

Varmforsinket uten sertifikat

*Alle laster med en sikkerhetsfaktor på 5