



User Manual

ArtGate DMX-Ethernet converters

RGS-X-DB-AC, RGS-X-2D2B-AC, RGS-X-DB-DC, RGS-X-2D2B-DC,
RGA-0-DB-AC, RGA-0-2D2B-AC, RGA-0-DB-DC, RGA-0-2D2B-DC,
RGS-X-4D2B-AC, RGS-X-4D2B-DC, RGA-0-4D2B-AC, RGA-0-4D2B-DC, GJP-5-8D5EF

Contents

Specifications	3
General information	4
Safe operation	4
Merging	5
Input processing	6
Standalone merger	6
Trigger inputs	6
Connection types	6
Web interface settings	8
Main settings	9
Advanced settings	10
Network settings	12
Profiles	13
Firmware update	13
Technical maintenance	14

Specifications

DMX512 interfaces	1, 2, 4, 8 or 16
Supported protocols	DMX512, RDM (E1.20), ArtNet (I,II,III,4), sACN (E1.31, draft and release), KiNet (v1 and v2) RTTrPL, HTTP, etc.
DMX data refresh rate	44 Hz default, may be changed if necessary
I/O connectors	Depends on the modification
Max current consumption	0.1 A
Setup	web interface, specialized software ArtGate, ArtNet standard tools
Power supply	~90-250 V, 50/60 Hz or Power-over-Ethernet (PoE)
Fuse	0.1 A

General information

ArtGate is the series of full-featured converters for converting network protocols ArtNet and sACN to light fixtures control protocol DMX512. Through their 1, 2, 4, 8, 12 or 16 DMX ports, LAN interface and Optical port (ArtJet Pro and GigaJet Pro), the devices transmit and receive DMX512 data streams via Ethernet LAN functioning in 10Base-T or 100Base-T mode (100Base-FX in ArtJet Pro, 1000Base-FX in GigaJet Pro).

Compatibility with ArtNet and sACN protocols enables the use of ArtGate devices in a network of heterogeneous devices from other manufacturers.

As well as the standard broadcast data transfer ArtNet, ArtGate devices also support point-to-point data transfer in the local network or via the Internet. Address settings of the device (name, SubNet, Universe) and network settings (IP address, subnet mask, UDP-port), standard software tools for ArtNet networks, such as DMX Workshop, as well as using the web based interface.

Web-interface allows changing advanced settings of ArtGate devices not covered by the ArtNet standard, such as:

- DMX signal direction and merge mode for each port
- physical characteristics (timing) of DMX512 signal
- data stream transmission and reception modes in ArtNet network

In addition, specialized utility software allows advanced users to assign custom MAC address to the Ethernet interface of the device and restore default settings of the device. ArtGate series is powered by AC ~90-250 V, 50/60 Hz, or from Ethernet using the Power-over-Ethernet technology (depends on modification).

Safe operation

In installation, operation, preventive maintenance and repairs of the device, the requirements of the safety rules must be followed.

To ensure safe and reliable operation of the devices, please observe the following requirements:

- Use the device only for its intended purpose;
 - Do not use devices that shows signs of malfunctioning;
 - Avoid strong physical impacts on the device;
 - Protect devices and cables from contact with corrosive liquids.
- Whenever a fault is detected in the device, please contact the manufacturer.

Warning!

The device uses hazardous voltage AC 90-250V

Merging

HTP: highest takes precedence

LTP: latest takes precedence

AUTO: last modified takes precedence - intelligent merging mode

PRIORITY: for sACN streams with priority tag

BACKUP: primary/secondary universe backup

TRIGGER and X-FADE: dedicated channel / dedicated universe controllable merging

Merging and other output ports procedures for different merge modes are shown in Pic2, Pic3, Pic4, Pic5.

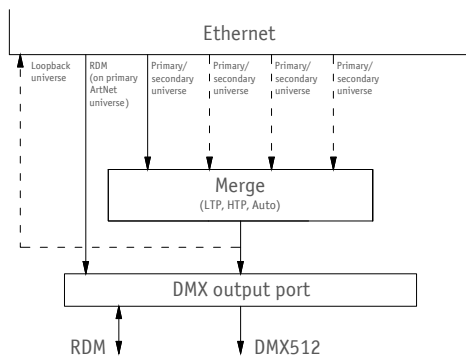

Pic.2 Output port procedures for LTP,HTP, Auto modes

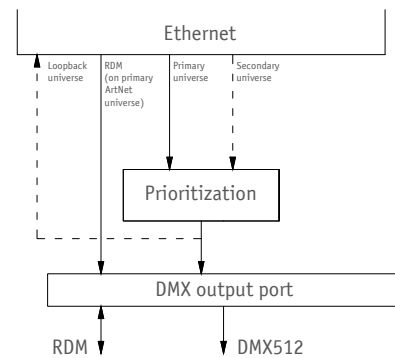

Pic.3 Output port procedures for Priority mode

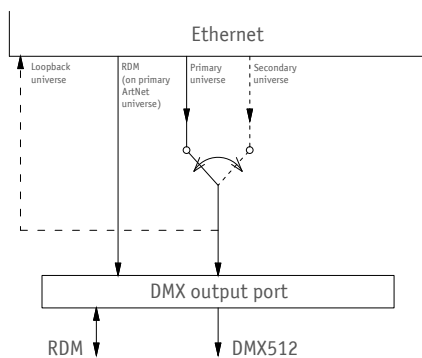

Pic.4 Output port procedures for Backup mode

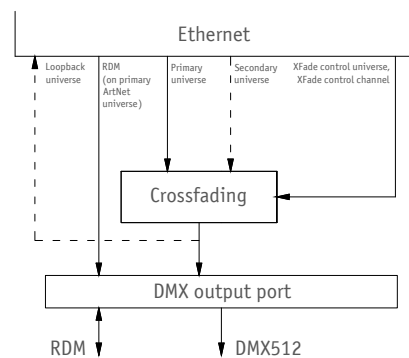

Pic.5 Output port procedures for Trigger and XFade modes

Input processing

When configured as input, DMX port of ArtGate can convert DMX512 signal to ArtNet, sACN or other type of universe. Universe type and protocol for input ports is always taken from primary universe settings. Input port can respond to RDM requests. Each port of one device has it's own RDM UID.

Standalone merger

ArtGate devices may be used as standalone (without permanent Ethernet connection) mergers. When 2 or more input ports are configured with the same universe protocol/number, DMX streams from them can be merged and outputted to another output port which must have the same protocol/number too to provide such feature. This configuration may work even if device is not connected to Ethernet.

Trigger inputs

Some ArtGate models have trigger feature. When trigger is activated, static scene stored in non-volatile memory is recalled and set for all DMX ports. Trigger is activated via "dry contact" inputs, which can be configured for working with normally opened and normally closed sensors (smoke sensors, buttons, etc). Each Trigger input can be also configured as alarm input. When alarm is activated, device returns to normal work only after power cycle or manual reset, not just input deactivation. By default, static scenes for all triggers are "all channels to 100%". User can set up the custom scene on all used DMX ports and then capture and save the scene for necessary trigger.

Connection types

Ethernet connection

Device is connected to the network via RJ-45. All ArtGate devices have two LEDs to indicate the status of the network connection.

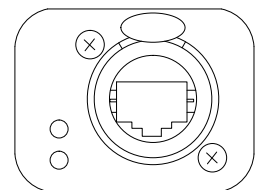

Pic.6 Ethernet connector

If there is no Ethernet connection, both LEDs are off, if network is connected, one LED is constantly on, the other one flashes when data are transmitted and received over the network. Each device has unique IP and MAC addresses. Device's IP address, subnet mask, and other network parameters can be changed, but even in this case, the device is still available on the original IP address (2.x.x.x) for ping and http requests. Thus, even in case of loss of the new IP address, the device can be access on the network using the original IP address through the web-interface.

Fiber optics connections

ArtJet devices are equipped with 100 Mbit fiber optics port (duplex SC connectors). Fiber optics port works as another network interface, with functionality similar to Ethernet port. When connected both to fiber optics and ethernet, device acts as a network switch/media converter.



Рис.7 Fiber optics connectors

DMX connections

XLR 5-pin connectors are used to connect external master and slave devices to DMX ports. If necessary, the device can be equipped with XLR three-pin connectors. Each port on the 2 and 4-port devices has 2 connectors — one M connector and one F connector, which allow the port to pass-through the DMX bus. On 8 and 16-port devices and ArtGate Compact, each port has single connector of type F. Each port is equipped with internal 120 ohms terminator which can be enabled via web interface.

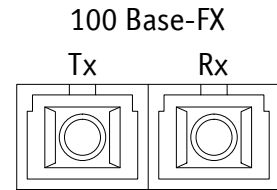

Рис.8 XLR(F) и XLR(M) DMX разъемы (5pins/3pins)

Web interface settings

ArtGate devices support configuring most of their parameters through the Web interface using HTTP protocol (TCP port 80).

Main settings

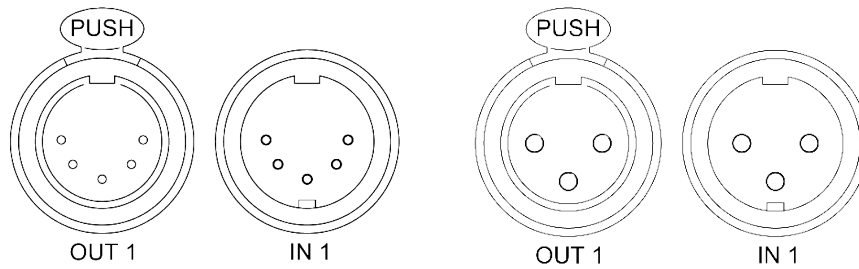
To access the settings page enter the IP address of the device to the browser. Main settings page of the ArtGate device will be displayed.

ArtGate Pro
Main settings

Indication: Normal Blink Off

Device name:

Device description:

Device status: Power-on tests successful

ArtNet4 Net address:

Port	Mode/merging	Pri. unv. protocol	Pri. unv. number	Sec. unv. protocol	Sec. unv. number	Status
DMX 1	Out/HTP	sACN	100	sACN	120	no new DMX data
DMX 2	Out/LTP	ArtNet	1	Disabled	0	transmitting DMX
DMX 3	Out/Auto	ArtNet	2	Disabled	0	no new DMX data
DMX 4	Out/Backup	ArtNet	3	ArtNet	23	transmitting DMX
DMX 5	In	ArtNet	85	Disabled	0	receiving DMX
DMX 6	Off	ArtNet	5	Disabled	0	-
DMX 7	Out/Trigger	ArtNet	78	sACN	1056	no new DMX data
DMX 8	Out/XFade	ArtNet	79	sACN	1053	no new DMX data

Save settings Set default Reset

www.sundrax.com

Pic.9
Main settings

Indication – switching LED indication modes:

- Normal** Indication depending on the current port status
- Blink** Search mode
- Off** LEDs are off

- Device name** Editable device name (up to 17 characters)
- Device description** Editable device description (up to 63 characters)
- Device status** Current state of the device
- ArtNet 4 Net address** Network number (0-127, only for ArtNet 4)

Ports – configuration and status for each DMX ports

- Mode/merging** Port direction and merge mode for output
- Pri. unv. protocol** Primary universe protocol
- Pri. unv. number** Primary universe number
- Sec. unv. protocol** Secondary universe protocol
- Sec. unv. number** Secondary universe number
- Status** Current state of the port

To save the changes in main settings, click **«Save settings»**.

To restore default values of main settings, click **«Set default»**.

To reset to the current saved values of main settings, click **«Reset»**.

Advanced settings

To edit the advanced settings of the device, click on the link **"Advanced"**.

ArtGate Pro

Advanced settings



Main
Advanced
Network
Profiles
Firmware

RDM devices:

```

DMX 1 - 1 devices found
           ManId: 29B7, DevId: A1153805
DMX 2 - 0 devices found
DMX 3 - 0 devices found
DMX 4 - 0 devices found
DMX 7 - 0 devices found
DMX 8 - 0 devices found
          
```

Start discovery
Refresh report

DMX signal timing:

Break, usec	MaB, usec	Data slots	Pause, usec
200	20	512	0

DMX line terminator:

Port	1	2	3	4	5	6	7	8
	<input checked="" type="checkbox"/>	<input checked="" type="checkbox"/>	<input type="checkbox"/>	<input type="checkbox"/>	<input type="checkbox"/>	<input type="checkbox"/>	<input checked="" type="checkbox"/>	<input checked="" type="checkbox"/>

Options:

Frame integrity mode	ArtNet Subnet-Unv. mode	ArtNet 4 support	sACN Release	KiNet v2
<input checked="" type="checkbox"/>	<input type="checkbox"/>	<input checked="" type="checkbox"/>	<input checked="" type="checkbox"/>	<input checked="" type="checkbox"/>

Advanced port settings:

Port	Src. timeout, sec	XFade unv. protocol	XFade unv. number	XFade unv. channel	Loop. unv. protocol	Loop. unv. number
DMX 1	30	Disabled ▼	0	512	ArtNet ▼	80
DMX 2	30	Disabled ▼	0	512	ArtNet ▼	81
DMX 3	10	Disabled ▼	0	512	Disabled ▼	0
DMX 4	10	Disabled ▼	0	512	Disabled ▼	0
DMX 5	10	Disabled ▼	0	512	Disabled ▼	0
DMX 6	10	Disabled ▼	0	512	Disabled ▼	0
DMX 7	10	ArtNet ▼	130	510	Disabled ▼	0
DMX 8	10	ArtNet ▼	130	511	Disabled ▼	0

Triggers/alarms:

Input	Mode	Delay, msec	Action	Status
Trigger 1	Alarm, N.O. ▼	0	Capture scene	open
Trigger 2	Trigger, N.O. ▼	5000	Capture scene	open

Save settings
Set default
Reset

www.sundrax.com

Pic.10

Advanced settings

RDM devices – RDM devices list, connected to DMX ports:

Start discovery

Searching connected devices

Refresh report

Refresh search/list state detected devices

DMX signal timing – sets the parameters of the output DMX signal for all ports:

Break	from 4 to 1000 μ s
MaB	from 4 to 1000 μ s
Data slots	1 to 512
Pause	from 0 to 10000 μ s

DMX line terminator – enables (selected) or disables (cleared) termination resistor between D+ and D- wires of DMX line on each port.

Options – enable/disable device features.

Advanced port settings – settings for advanced features for each port:

Src. timeout	Universe source timeout, in seconds
Trigger/XFade unv. protocol	XFade/Trigger control universe protocol
Trigger/XFade unv. number	XFade/Trigger control universe number
Trigger/XFade control channel	XFade/Trigger control channel
Loop. unv. protocol	Loop back universe protocol
Loop. unv. number	Loop back universe number

Triggers/alarms – (for ArtGates equipped with Trigger inputs)- setup the mode of Trigger inputs:

Input	Trigger/Sensor input
Mode	Operating mode (disabled, trigger/alarm sensor normally open/closed)
Delay, ms	Delay for triggering in milliseconds
Status	Current status of input (open, closed, active, alarm)
Action	Save the current state of all DMX ports as scene to recall on trigger activation

To save the changes in advanced settings, click **«Save settings»**.

To restore default values of advanced settings, click **«Set default»**.

To reset to the current saved values of advanced settings, click **«Reset»**.

Network settings

To edit the network settings of the device, click on the link "Network".

ArtGate Pro
Network settings

Pic. 11
Network settings

Main Advanced **Network** Profiles Firmware

MAC address: 00:02:8C:A6:15:3B (secondary IP: 2.161.21.59)

Main IP: 2.161.21.59

Subnetwork mask: 255.0.0.0

Gateway IP: 0.0.0.0

ArtNet UDP port: 6454

sACN UDP port: 5568

Access login: admin

Access password:

Save settings Set default Reset www.sundrax.com

MAC address	Hardware address and secondary (permanent) IP-address of the device
Main IP	Set the main network address of the device
Subnetwork mask	Set the mask of the IP-subnet
Gateway IP address	Set the network address of the gateway (if ability to operate via the Internet is required)
Art-Net UDP port	Set the UDP-port for ArtNet protocol
sACN UDP port	Set the UDP-port for sACN protocol
Access login/password	Login and password for access to web-interface of device. If password is empty, authentication is not performed

To save the changes in network settings, click «**Save settings**».

To restore default values of network settings, click «**Set default**».

To reset to the current saved values of network settings, click «**Reset**».

Profiles

For profile operations, click on the link «**Profiles**».

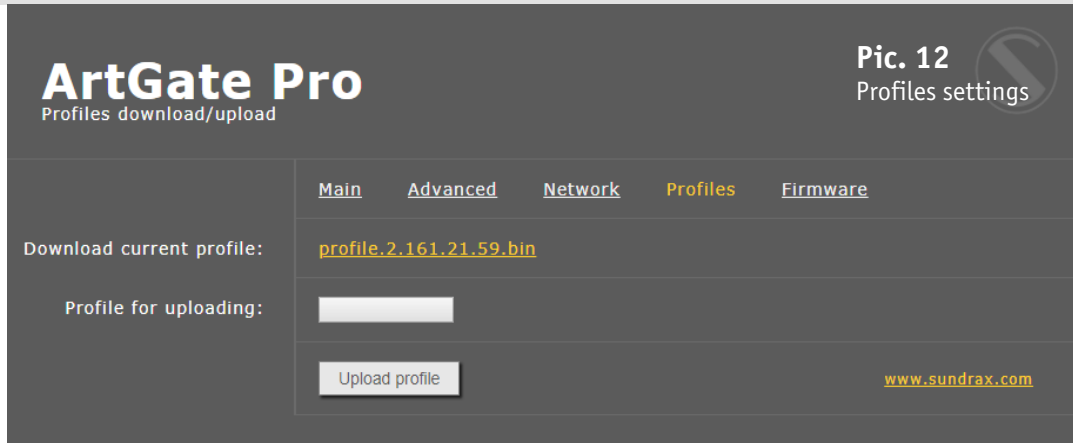

Pic. 12
Profiles settings

Download current profile
Profile for uploading
Upload profile

Download the current settings as a file
Select the file of previously saved profile
To upload the selected profile in the device

Firmware update

To update firmware of the device, click on the link «**Firmware**».

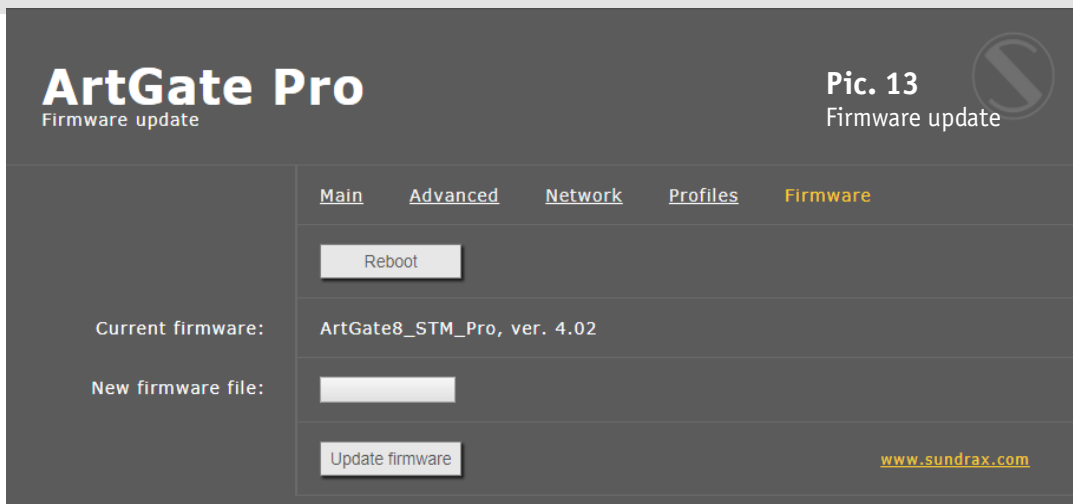

Pic. 13
Firmware update

Reboot
Current firmware
New firmware file
Update firmware

Device reboot button
Current firmware name and version
Select firmware file to upload to the device
Upload the selected firmware file

After software update downloading, need to accept updating by clicking button «**Reboot**».

Technical maintenance

Maintenance, search and troubleshooting should be performed by service personnel. The device should be free from dirt, dents, connecting cables and wires must be intact and securely fastened.

Notes



Sundrax Electronics
6008, First Central 200
2 Lakeside Drive, Park Royal, London
NW10 7FQ United Kingdom
+ 44 (0) 208 991 33 19
office@sundrax.com
www.sundrax.com

