



User Manual

LEDGate Compact

LGC-1-D4LED, LGCS-1-D4LED, WLGC-1-DC4LED,
LGB-1-D4LED, WLGB-1-DC4LED

Contents

Specifications	3
Safe operation	3
General information	3
Advantages	4
Modifications	4
Installation	4
Indication	5
Connection scheme	6
Technical maintenance	7
Notes	7

Specifications

Control interface	DMX512, BeDMX (optional)
Transmission range	100 m (standard antenna)
RF band	2.4 GHz
LED outputs	2 or 4
Wireless interface	depends on modification
DMX512 interfaces	1 or 2
Connectors	15 EDGV
Setup	DIP rotor switchers
Power supply	12/24 VDC
Max current per output	20 A
Operating Temperature	-40°C... +70°C
IP Rating	IP 20
Dimensions, mm	86 x 38 x 54 DMX version 110 x 38 x 54 DMX/BeDMX version

Safe operation

To ensure safe and reliable operation of the devices, please observe the following requirements

- Use the device only for its intended purpose
- Do not use devices that show signs of malfunctioning
- Avoid strong physical impacts on the device
- Protect devices and cables from contact with corrosive liquids
- Whenever a fault is detected in the device, please contact the manufacturer.

Warning!

The device uses hazardous voltage AC 90-250V

General information

Wireless LEDGate Compact is compact LED driver with DMX512 and BeDMX inputs. Powered from 12/24 VDC source, LEDGate is capable to control and dim 2 or 4 output lines for direct connection with LED equipment: duralight, driverless LED luminaires, etc, with independent short-circuit protection on each channel. The device is equipped with coaxial RP-SMA RF connector for antenna connection to work as BeDMX receiver. DMX512 input is also available. Thanks to innovative embedded algorithms, LEDGate provides a smooth, stepless regulation in full range of intensity.

Advantages

- Direct connection with LED equipment
- Smooth light regulation
- Independent short-circuit protection on each channel
- Wireless BeDMX connection (optional)
- Chain connection of the LEDGate Slave Compact (optional)

Modifications

Product code	LGC-1-D2LED	LGC-1-D4LED	LGC-1-DB2LED	LGC-1-DB4LED	LGCS-1-D2LED	LGCS-1-D4LED
Name	LEDGate Compact	LEDGate Compact	Wireless LEDGate Compact	Wireless LEDGate Compact	LEDGate Compact Slave	LEDGate Compact Slave
Outputs	2	4	2	4	2	4
Wireless interface	No	No	Yes	Yes	No	No
Address switchers	Yes	Yes	Yes	Yes	No	No

Installation

Before mounting and power up, it is necessary to verify protective earthing and cable connections.

1. Ensure the device has no damage due to transportation.
2. Fix the device on the surface. If you are using wireless modification, connect the antenna.
3. Connect the power cable, input DMX line and LED stripes. If you want connect slave devices, connect LEDGate Compact Slave to Slave Out connector. If you use Wireless LEDGate Compact and connect both DMX and BeDMX, priority has DMX. For connection via BeDMX, DMX line should be disabled.
4. Set device address using DIP rotor switchers. Range of valid addresses starts with 001, (default) and ends with 509. Starting with this address device will be controlled from an external remote. LEDGate Compact Slave modification not equipped with DIP rotor switchers, starting address for LEDGate Compact Slave devices equals the address of the previous device in the chain plus 4.

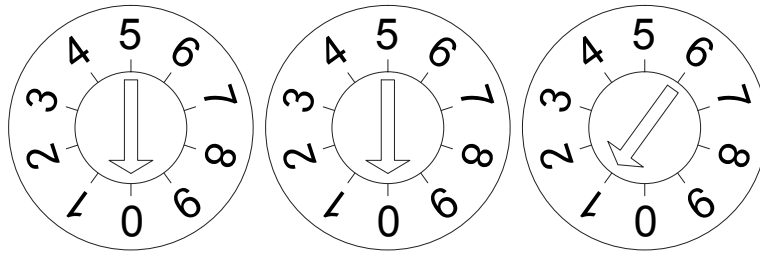

Pic.1 Default device address (001) (OEM version)

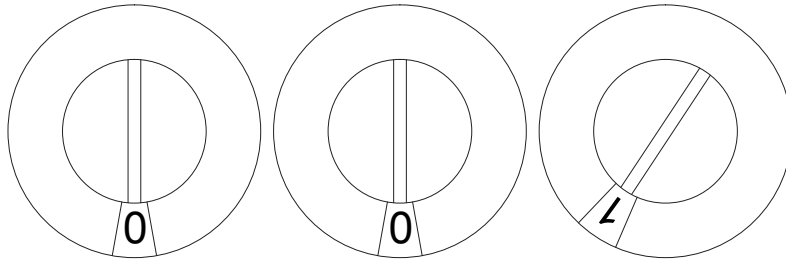

Pic.2 Default device address (001) (Retail version)

Indication

Red	lit	Address is correct, no DMX data.
	blinks	Address is not valid.
Green	lit	Address is correct, the data is coming from DMX.
	blins	Changed control value DMX.

Connection scheme

DMX, BeDMX and Slave connection

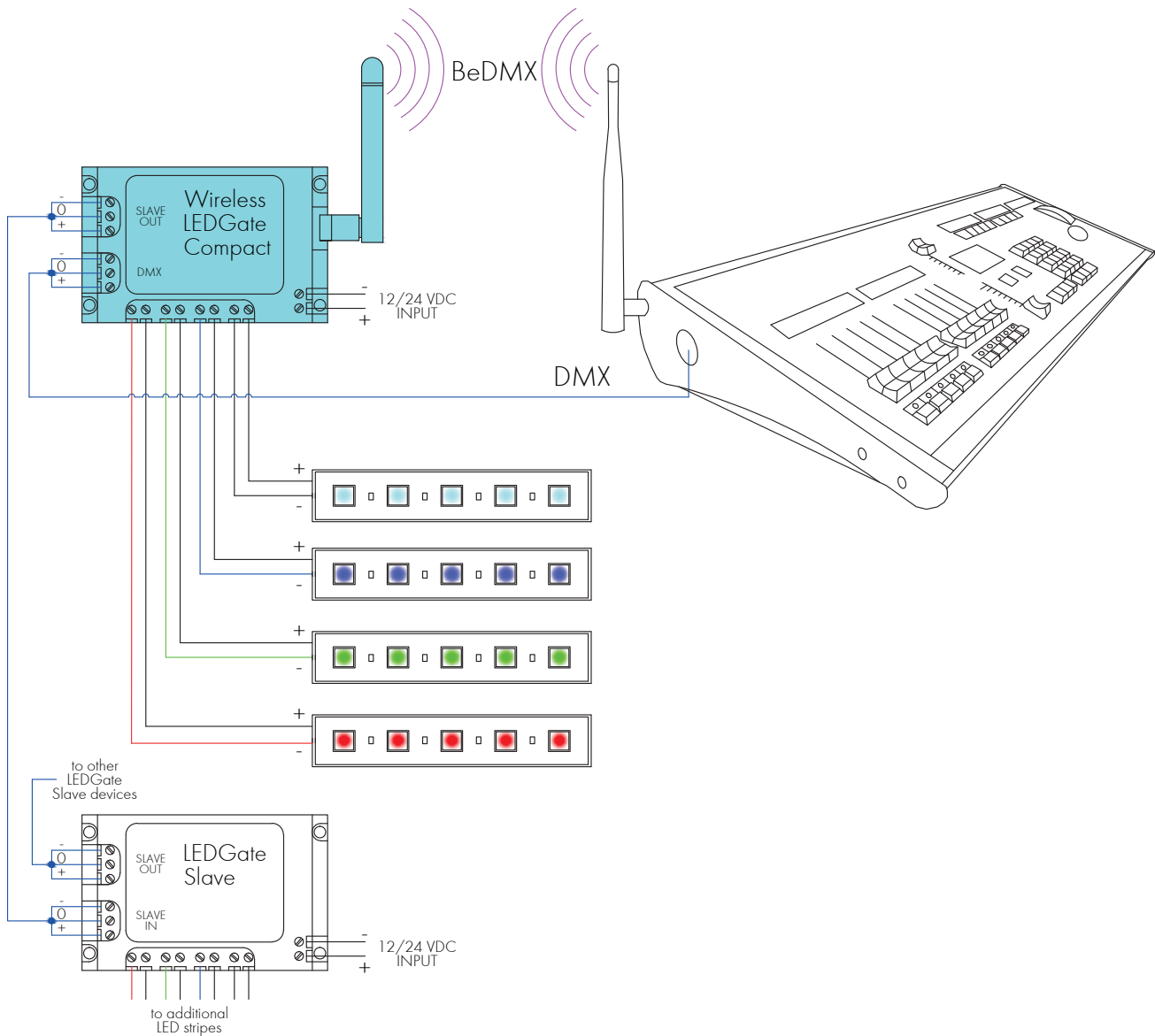

Mounting dimensions

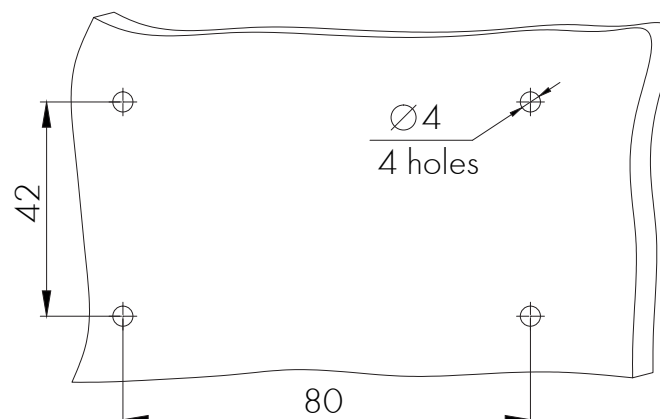

Technical maintenance

Maintenance, search and troubleshooting should be performed by service personnel. The device should be free from dirt, dents, connecting cables and wires must be intact and securely fastened.

Notes



Sundrax Electronics
6008, First Central 200
2 Lakeside Drive, Park Royal, London
NW10 7FQ United Kingdom
+ 44 (0) 208 991 33 19
office@sundrax.com
www.sundrax.com