



POWERED SPEAKER

DXR Series

DXR8 DXR10 DXR12 DXR15

POWERED SUBWOOFER

DXS Series

DXS12 DXS15

OWNER'S MANUAL

BEDIENUNGSANLEITUNG

MODE D'EMPLOI

MANUAL DE INSTRUCCIONES

MANUALE DI ISTRUZIONI

РУКОВОДСТВО ПОЛЬЗОВАТЕЛЯ

使用说明书

取扱説明書

EN
DE
FR
ES
IT
RU
ZH
JA

English

Deutsch

Français

Español

Italiano

Русский

中文

日本語

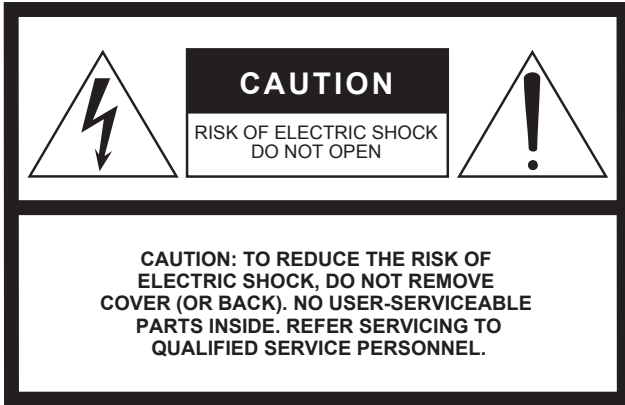

Explanation of Graphical Symbols

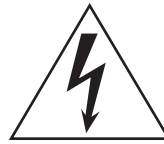

The lightning flash with arrowhead symbol within an equilateral triangle is intended to alert the user to the presence of uninsulated “dangerous voltage” within the product’s enclosure that may be of sufficient magnitude to constitute a risk of electric shock to persons.



The exclamation point within an equilateral triangle is intended to alert the user to the presence of important operating and maintenance (servicing) instructions in the literature accompanying the product.

The above warning is located on the rear of the unit.

IMPORTANT SAFETY INSTRUCTIONS

- 1 Read these instructions.
- 2 Keep these instructions.
- 3 Heed all warnings.
- 4 Follow all instructions.
- 5 Do not use this apparatus near water.
- 6 Clean only with dry cloth.
- 7 Do not block any ventilation openings. Install in accordance with the manufacturer’s instructions.
- 8 Do not install near any heat sources such as radiators, heat registers, stoves, or other apparatus (including amplifiers) that produce heat.
- 9 Do not defeat the safety purpose of the polarized or grounding-type plug. A polarized plug has two blades with one wider than the other. A grounding type plug has two blades and a third grounding prong. The wide blade or the third prong are provided for your safety. If the provided plug does not fit into your outlet, consult an electrician for replacement of the obsolete outlet.
- 10 Protect the power cord from being walked on or pinched particularly at plugs, convenience receptacles, and the point where they exit from the apparatus.
- 11 Only use attachments/accessories specified by the manufacturer.
- 12 Use only with the cart, stand, tripod, bracket, or table specified by the manufacturer, or sold with the apparatus. When a cart is used, use caution when moving the cart/apparatus combination to avoid injury from tip-over.
- 13 Unplug this apparatus during lightning storms or when unused for long periods of time.
- 14 Refer all servicing to qualified service personnel. Servicing is required when the apparatus has been damaged in any way, such as power-supply cord or plug is damaged, liquid has been spilled or objects have fallen into the apparatus, the apparatus has been exposed to rain or moisture, does not operate normally, or has been dropped.



WARNING

TO REDUCE THE RISK OF FIRE OR ELECTRIC SHOCK, DO NOT EXPOSE THIS APPARATUS TO RAIN OR MOISTURE.

(UL60065_03)

FCC INFORMATION (U.S.A.)

1. IMPORTANT NOTICE: DO NOT MODIFY THIS UNIT!

This product, when installed as indicated in the instructions contained in this manual, meets FCC requirements. Modifications not expressly approved by Yamaha may void your authority, granted by the FCC, to use the product.

2. IMPORTANT: When connecting this product to accessories and/or another product use only high quality shielded cables. Cable/s supplied with this product **MUST** be used. Follow all installation instructions. Failure to follow instructions could void your FCC authorization to use this product in the USA.

3. NOTE: This product has been tested and found to comply with the requirements listed in FCC Regulations, Part 15 for Class "B" digital devices. Compliance with these requirements provides a reasonable level of assurance that your use of this product in a residential environment will not result in harmful interference with other electronic devices. This equipment generates/uses radio frequencies and, if not installed and used according to the instructions found in the users manual, may cause interference harmful to the operation of other electronic devices. Compliance with FCC regulations does not guarantee that interference will not occur in

all installations. If this product is found to be the source of interference, which can be determined by turning the unit "OFF" and "ON", please try to eliminate the problem by using one of the following measures:

Relocate either this product or the device that is being affected by the interference.

Utilize power outlets that are on different branch (circuit breaker or fuse) circuits or install AC line filter/s.

In the case of radio or TV interference, relocate/reorient the antenna. If the antenna lead-in is 300 ohm ribbon lead, change the lead-in to co-axial type cable.

If these corrective measures do not produce satisfactory results, please contact the local retailer authorized to distribute this type of product. If you can not locate the appropriate retailer, please contact Yamaha Corporation of America, Electronic Service Division, 6600 Orangethorpe Ave, Buena Park, CA90620

The above statements apply **ONLY** to those products distributed by Yamaha Corporation of America or its subsidiaries.

* This applies only to products distributed by YAMAHA CORPORATION OF AMERICA.

(class B)

In Finland: Laitte on liitettävä suojamaadoituskoskettimilla varustettuun pistorasiaan.

In Norway: Apparatet må tilkoples jordet stikkontakt.

In Sweden: Apparaten skall anslutas till jordat uttag.

(class I hokuo)

IMPORTANT NOTICE FOR THE UNITED KINGDOM

Connecting the Plug and Cord

WARNING: THIS APPARATUS MUST BE EARTHED IMPORTANT. The wires in this mains lead are coloured in accordance with the following code:

GREEN-AND-YELLOW	: EARTH
BLUE	: NEUTRAL
BROWN	: LIVE

As the colours of the wires in the mains lead of this apparatus may not correspond with the coloured markings identifying the terminals in your plug proceed as follows:

The wire which is coloured GREEN-and-YELLOW must be connected to the terminal in the plug which is marked by the letter E or by the safety earth symbol  or colored GREEN or GREEN-and-YELLOW.

The wire which is coloured BLUE must be connected to the terminal which is marked with the letter N or coloured BLACK.

The wire which is coloured BROWN must be connected to the terminal which is marked with the letter L or coloured RED.

(3 wires)

THIS DEVICE COMPLIES WITH PART 15 OF THE FCC RULES. OPERATION IS SUBJECT TO THE FOLLOWING TWO CONDITIONS:

- (1) THIS DEVICE MAY NOT CAUSE HARMFUL INTERFERENCE, AND
- (2) THIS DEVICE MUST ACCEPT ANY INTERFERENCE RECEIVED, INCLUDING INTERFERENCE THAT MAY CAUSE UNDESIRE OPERATION.

* This applies only to products distributed by YAMAHA CORPORATION OF AMERICA.

* This information is located on the bottom of the unit.

THIS CLASS B DIGITAL APPARATUS COMPLIES WITH CANADIAN ICES-003.
CET APPAREIL NUMÉRIQUE DE LA CLASSE B EST CONFORME À LA NORME NMB-003 DU CANADA.

* This information is located on the bottom of the unit.

PRECAUTIONS

PLEASE READ CAREFULLY BEFORE PROCEEDING

* Please keep this manual in a safe place for future reference.



WARNING

Always follow the basic precautions listed below to avoid the possibility of serious injury or even death from electrical shock, short-circuiting, damages, fire or other hazards. These precautions include, but are not limited to, the following:

Power supply/Power cord

- Do not place the power cord near heat sources such as heaters or radiators, and do not excessively bend or otherwise damage the cord, place heavy objects on it, or place it in a position where anyone could walk on, trip over, or roll anything over it.
- Only use the voltage specified as correct for the device. The required voltage is printed on the name plate of the device.
- Use only the supplied power cord/plug.
If you intend to use the device in an area other than in the one you purchased, the included power cord may not be compatible. Please check with your Yamaha dealer.
- Check the electric plug periodically and remove any dirt or dust which may have accumulated on it.
- Be sure to connect to an appropriate outlet with a protective grounding connection. Improper grounding can result in electrical shock.

Do not open

- This device contains no user-serviceable parts. Do not open the device or attempt to disassemble the internal parts or modify them in any way. If it should appear to be malfunctioning, discontinue use immediately and have it inspected by qualified Yamaha service personnel.

Water warning

- Do not expose the device to rain, use it near water or in damp or wet conditions, or place on it any containers (such as vases, bottles or glasses) containing liquids which might spill into any openings. If any liquid such as water seeps into the device, turn off the power immediately and unplug the power cord from the AC outlet. Then have the device inspected by qualified Yamaha service personnel.
- Never insert or remove an electric plug with wet hands.

Fire warning

- Do not put burning items, such as candles, on the unit. A burning item may fall over and cause a fire.

If you notice any abnormality

- When one of the following problems occur, immediately turn off the power switch and disconnect the electric plug from the outlet. Then have the device inspected by Yamaha service personnel.
 - The power cord or plug becomes frayed or damaged.
 - It emits unusual smells or smoke.
 - Some object has been dropped into the instrument.
 - There is a sudden loss of sound during use of the device.
- If this device should be dropped or damaged, immediately turn off the power switch, disconnect the electric plug from the outlet, and have the device inspected by qualified Yamaha service personnel.



CAUTION

Always follow the basic precautions listed below to avoid the possibility of physical injury to you or others, or damage to the device or other property. These precautions include, but are not limited to, the following:

Power supply/Power cord

- When removing the electric plug from the device or an outlet, always hold the plug itself and not the cord. Pulling by the cord can damage it.
- Remove the electric plug from the outlet when the device is not to be used for extended periods of time, or during electrical storms.

Location

- Do not place the device in an unstable position where it might accidentally fall over.
- Unless the device is securely affixed, do not install it in a location where it might fall, even if the surface is level.
- Do not block the vents. This device has ventilation holes at the rear to prevent the internal temperature from becoming too high. Inadequate ventilation can result in overheating, possibly causing damage to the device(s), or even fire.

- Do not use the device in a confined, poorly-ventilated location. Make sure that there is adequate space between the device and surrounding walls or other devices: at least 30cm at the sides, 30cm behind and 30cm above. Inadequate ventilation can result in overheating, possibly causing damage to the device(s), or even fire.
- Do not use the speaker's handles for suspended installation. Doing so can result in damage or injury.
- Do not hold the bottom of the device when transporting or moving it. In doing so, you may pinch your hands under the device, and result in injury.
- Do not press the rear panel of the device against the wall. Doing so may cause the plug to come in contact with the wall and detach from the power cord, resulting in short circuiting, malfunction, or even fire.
- Do not place the device in a location where it may come into contact with corrosive gases or salt air. Doing so may result in malfunction.
- Before moving the device, remove all connected cables.

- When setting up the device, make sure that the AC outlet you are using is easily accessible. If some trouble or malfunction occurs, immediately turn off the power switch and disconnect the plug from the outlet. Even when the power switch is turned off, electricity is still flowing to the product at the minimum level. When you are not using the product for a long time, make sure to unplug the power cord from the wall AC outlet.
- When transporting or moving the DXS15, DXS12, or DXR15, always use two or more people. Attempting to lift the DXS15, DXS12, or DXR15, by yourself may damage your back, result in other injury, or cause damage to the device itself.
- If you use the pole socket on the DXS15 to mount a satellite speaker, use a speaker of 19.3kg (42.5lbs) or less in weight and 60.1cm (23-5/8") or less in height. If you use the pole socket on the DXS12 to mount a satellite speaker, use a speaker of 14.6kg (32.2lbs) or less in weight and 50.2cm (19-6/8") or less in height. Also, use a speaker pole no longer than 120cm (47.2") with an outer diameter of 35mm (1-3/8").
- Always consult qualified Yamaha service personnel if the device installation requires construction work, and make sure to observe the following precautions.
 - Choose mounting hardware and an installation location that can support the weight of the device.
 - Avoid locations that are exposed to constant vibration.
 - Use the required tools to install the device.
 - Inspect the device periodically.

Connections

- Before connecting the device to other devices, turn off the power for all devices. Before turning the power on or off for all devices, set all volume levels to minimum.

Maintenance

- Remove the power plug from the AC outlet when cleaning the device.

Handling caution

- Do not insert your fingers or hands in any gaps or openings on the device (panel).
- Avoid inserting or dropping foreign objects (paper, plastic, metal, etc.) into any gaps or openings on the device (panel). If this happens, turn off the power immediately and unplug the power cord from the AC outlet. Then have the device inspected by qualified Yamaha service personnel.
- Do not rest your weight on the device or place heavy objects on it, and avoid use excessive force on the buttons, switches or connectors.
- Do not use the device for a long period of time at a high or uncomfortable volume level, since this can cause permanent hearing loss. If you experience any hearing loss or ringing in the ears, consult a physician.
- Do not operate the device if the sound is distorting. Prolonged use in this condition could cause overheating and result in fire.
- Do not pull the cables connected to the microphones, etc.

XLR-type connectors are wired as follows (IEC60268 standard): pin 1: ground, pin 2: hot (+), and pin 3: cold (-).

Interference From Cell Phones

Using a cell phone near the speaker system can induce noise. If this occurs, move the cell phone further away from the speaker system.

Yamaha cannot be held responsible for damage caused by improper use or modifications to the device, or data that is lost or destroyed.

Always turn the power off when the device is not in use.

The performance of components with moving contacts, such as switches, volume controls, and connectors, deteriorates over time. Consult qualified Yamaha service personnel about replacing defective components.

- The company names and product names in this manual are the trademarks or registered trademarks of their respective companies.
- The illustrations as shown in this manual are for instructional purposes only, and may appear somewhat different from those on your instrument.
- Specifications and descriptions in this owner's manual are for information purposes only. Yamaha Corp. reserves the right to change or modify products or specifications at any time without prior notice. Since specifications, equipment or options may not be the same in every locale, please check with your Yamaha dealer.

Introduction

Thank you for purchasing the Yamaha DXR series powered speaker or DXS series powered subwoofer. Please read this manual thoroughly to ensure optimum use of the DXR/DXS series for the longest possible period of time. Keep the manual in a safe place for future reference.

Contents

Introduction.....	6	Setup Examples	10
Main Features of the DXR/DXS Series.....	6	Troubleshooting.....	12
Controls and Functions	7	References	80

Main Features of the DXR/DXS Series

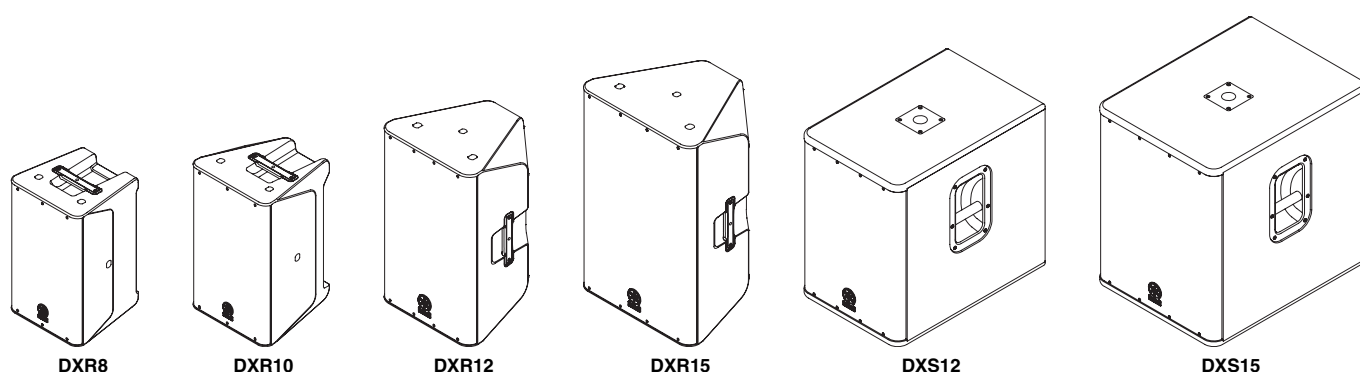

■ FIR-X tuning™(DXR series)

The advanced DSP processing featured in these series has been inherited from the high-end DSR series. Our proprietary sound-processing technology utilizing a linear-phase FIR filter delivers excellent sound quality at high resolution with a smooth frequency response that is unaffected by phase interference near the crossover point.

■ D-CONTOUR (Dynamic CONTOUR) (DXR series)

D-CONTOUR is a multiband compressor that dynamically controls the level of each frequency range according to the application and human hearing characteristics. It features a FOH/MAIN mode for using your DXR as a main speaker, and a MONITOR mode that has been optimized for use as a floor monitor. Select the mode that suits your application.

■ D-XSUB (DXS series)

D-XSUB is a newly-developed processing technology exclusively for subwoofers that dynamically controls the low frequency range. It features a BOOST mode that enhances and provides punch to the sound, and an XTENDED LF mode that extends the bottom of the low frequency range. You can select either mode in accordance with various applications and musical genres.

■ Mixing/LINK functionality (DXR series)

The DXR series features mixing functionality, enabling you to mix sounds by directly inputting three channel signals into the unit.

In addition, the LINK function enables you to easily configure a stereo or dual-mono SR (Sound Reinforcement) system using two DXRs.

■ DSP-controlled advanced protection system

Powerful protection circuits ensure secure protection in the speaker unit, amplifier unit, and power supply unit. This protection functionality promotes optimal performance of each component and optimum reliability without distortion even in challenging environments.

Included Accessories

- AC power cord
- Owner's manual (this book)

Optional accessories

U brackets for mounting the DXR series on the wall or ceiling are available as follows:

- UB-DXR15 (for DXR15)
- UB-DXR12 (for DXR12)
- UB-DXR10 (for DXR10)
- UB-DXR8 (for DXR8)

Controls and Functions

Rear panel

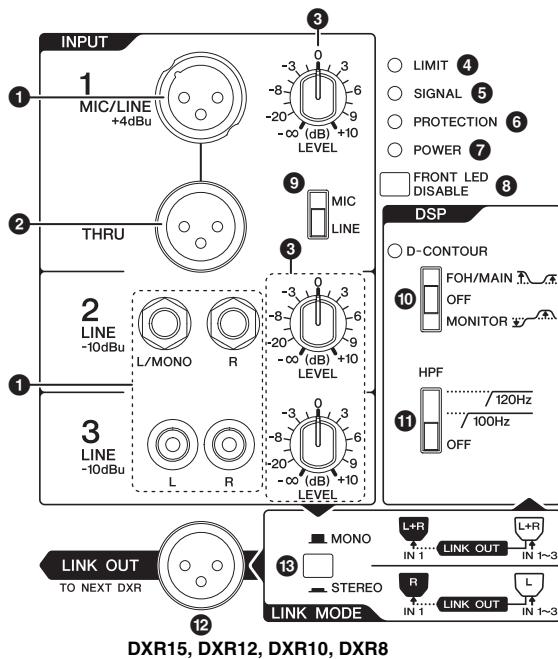

DXR15, DXR12, DXR10, DXR8

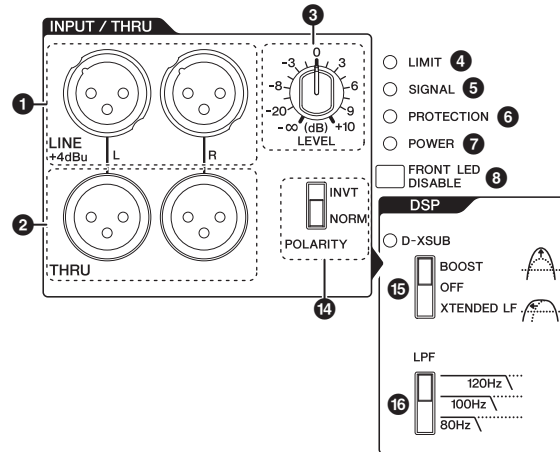

DXS15, DXS12

1 INPUT jacks

These are balanced XLR input jack(s) (INPUT 1), unbalanced phones (INPUT 2) and RCA pin input jacks (INPUT 3).

You can connect a mixing console or microphone to INPUT 1, a keyboard or electric-acoustic guitar to INPUT 2, and a portable audio player or CD player to INPUT 3. Signals from INPUT 1-3 are mixed inside the DXR unit.

The DXS series input features only balanced XLR input jacks (L, R). L and R signals are mixed inside the DXS unit.

2 THRU jack(s)

These are balanced XLR output jack(s). Input signals will be passed through unaffected, since these are parallel connected to the INPUT jacks.

3 LEVEL control

Adjusts the level of each INPUT signal. If you connect a device that features a nominal output level of +4dBu (such as a mixing console), set the MIC/LINE switch (9) on the DXR series to LINE, and adjust the LEVEL control using its 12 o'clock position as a reference.

4 LIMIT indicator

Lights when the output limiter is active. The output limiter will operate in order to protect the speaker and amp, attenuating the output signal to the amplifier. If this indicator stays lit, lower the level of the input signal.

NOTE

- If the output voltage of the amplifier has exceeded the maximum value, or if excessive integral power consumption is detected, the LIMIT indicator will light when the amount of attenuation is 3dB or higher.
- The integral power consumption refers to the sum of power consumption provided to the speaker driver per unit time.

5 SIGNAL indicator

Lights when an audio input signal is detected.

6 PROTECTION indicator

Lights when the protection system is active. The protection system will operate and the speaker output will be muted in the following situations.

- **If amplifier overheating is detected:**
- **If DC output is detected:**
- **If overcurrent is detected:**
- **When turning the power on:**
The protection system will be activated to prevent noise and the indicator will light for about two seconds. The indicator turns off when the power supply has started normally.
- **When turning the power off:**
Or if the power turns off due to an unexpected error, the protection system will be activated to prevent noise, and then the power will be shut down.

NOTE

If the protection system has engaged after the problem was detected, waiting until the amplifier cools down or powering off and on again will return to normal operation. If the unit does not return to normal operation, please contact your Yamaha dealer.

Controls and Functions

7 POWER indicator

Lights when the power switch (13) is set to on.

8 FRONT LED DISABLE switch

Selects turning on or off the FRONT LED at the left of the unit's front grille. The LED will light when this switch is set to off (■). Turn this switch on (▬) when you want to turn off the LED.

NOTE

When the limiter for protecting the amplifier operates, the LED will light brighter than usual in proportion to the amount of attenuation (3dB or higher).

9 MIC/LINE switch (DXR series)

Set this switch to MIC or LINE for INPUT1 jack, depending on the level of the input signal. For low-level signals (such as microphones), set the switch to the MIC position. For high level signals (such as mixer), set the switch to the LINE position.

10 D-CONTOUR switch (DXR series)

Selects one of the D-CONTOUR (Dynamic CONTOUR) presets. The FOH/MAIN setting will boost the high and low frequency components so that the frequency response will become suitable for a main speaker. The MONITOR setting also suppresses the low range, which could otherwise tend to be boomy if the speaker is set directly on the floor or used along with a main speaker. With the FOH/MAIN or MONITOR setting, the D-CONTOUR function is enabled and controls the boost and attenuation amounts dynamically in relation to the sound volume. When this switch is set to OFF, a generic frequency response setting will be used and the D-CONTOUR function will be turned off.

11 HPF switch (DXR series)

Specifies the HPF's cut-off frequency.

If the switch is set to 120Hz or 100Hz, the high-pass filter will cut the frequency components below that threshold. If you plan to use your DXR without a subwoofer, set this switch to OFF. If you plan to use the DXR along with a subwoofer, we recommend that you set this switch to 120Hz or 100Hz.

12 LINK OUT jack (DXR series)

This XLR jack outputs signals (routed from each INPUT jack) to a connected DXR series speaker. Connect this jack to the INPUT 1 (XLR) jack on the linked DXR series speaker.

Signals at the LINK OUT jack are line-level. Set the MIC/LINE switch on the linked DXR series speaker to LINE. For stereo signals, set the LEVEL control on the linked DXR to the 12 o'clock position to balance the levels between two DXRs.

13 LINK MODE switch (DXR series)

Enables you to select whether the mixed signal (on the original DXR) will be played in stereo or monaural on the original and linked DXRs. The following signals are mixed and output according to the switch setting.

LINK MODE	STEREO			MONO		
	INPUT1	INPUT2/3		INPUT1	INPUT2/3	
L		R	L		R	
Input of the original DXR						
Output of the original DXR	✓	✓	–	✓		
Output of the linked DXR	✓	–	✓	✓		

NOTE

If you use only a single, stand-alone DXR, set this switch to MONO (■). If you set the switch to STEREO (▬), audio signals input at the R channel of INPUT 2/3 will not be output.

14 POLARITY switch (DXS series)

Selects the subwoofer polarity.

In most cases, for example if the subwoofer and DXR series speaker are installed on a speaker pole, set this switch to NORM (NORMAL). However, an INVT (INVERTED) setting may improve low-range response, depending on the type and location of the speaker system. Try both settings and select the one that produces the best low-end sound.

15 D-XSUB switch (DXS series)

Selects one of the D-XSUB presets. The BOOST setting boosts the low frequency range to enhance and punch-up the frequency response. The XTENDED LF extends the bottom of the low frequency range to enhance broad low-range frequency response. With the BOOST or XTENDED LF setting, the D-XSUB function is enabled and controls the boost amount dynamically in relation to the sound volume. When this is set to OFF, a generic frequency response will be used and the D-XSUB function will be turned off.

16 LPF switch (DXS series)

Specifies the low-pass filter's cutoff frequency at 120Hz, 100Hz, or 80Hz. The filter will cut the frequency components above the specified threshold. If you are using the DXS along with a DXR, match this frequency to DXR's HPF switch setting.

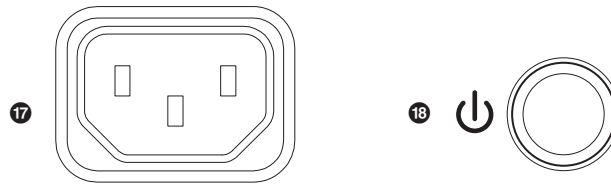

AC IN
DXR15, DXR12, DXR10, DXR8, DXS15, DXS12

17 AC IN socket

Connect the supplied AC power cord here. First, connect the power cord to the device, then insert the power cord plug into the AC outlet.

 Be sure to turn the power off before connecting or disconnecting the power cord.
CAUTION

18 Power switch

Turns the power supply on or off. Press the switch to the On position to turn the power on (⬆).

NOTE
If you are using multiple devices, turn on the power to each device individually. If you turn on the power to multiple devices simultaneously, a temporary drop in the power voltage may occur, possibly resulting in abnormal operation of the devices.

 Rapidly turning the unit on and off in succession can cause it to malfunction. After turning the unit off, wait for about 5 seconds before turning it on again.
CAUTION

Tiltable pole socket (DXR series)

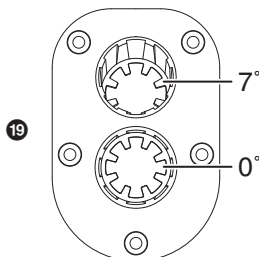

19 Tiltable pole socket (DXR series)

This mount has two pole sockets. You can choose the angle of the DXR (mounted on a speaker pole) so that the speaker will be horizontal to the floor or tilting toward the floor by 7 degrees.

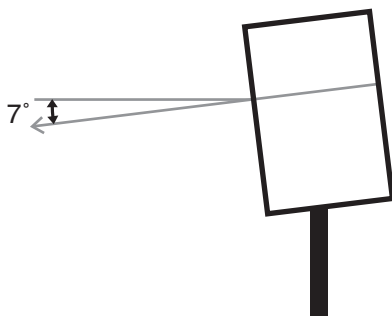

Suspended installation

If you plan to suspend your DXR series speaker, attach commercially-available eye bolts to the screw holes (which are sealed at the time of shipment) located on the top (two locations) and on the lower part of the rear (one location). The size of the screw holes on the DXR15 and DXR12 is M10 (for an eye bolt length of 18mm or less). The size of the screw holes on the DXR10 and DXR8 is M8 (for an eye bolt length of 15mm or less). Keep in mind that you will need three eye bolts to suspend it. Make sure to use the eye bolts according to the standards and safety regulations in your area.

 Before doing any installation or construction work, consult with an installation expert. When choosing the installation location, suspension wire and mounting hardware, make sure all are strong enough to support the weight of the speaker. Some fittings may deteriorate over extended periods of time due to wear and/or corrosion. For optimum safety, the installation should be checked thoroughly at regular intervals.

Yamaha cannot be held responsible for damage or injury caused by insufficient strength of the support structure or improper installation.

Setup Examples

English

1. Basic SR system

This example illustrates a basic SR system setup using two 2-way speakers. The system is suitable for a small-sized live space, a restaurant and a practice studio. As necessary, add a stage monitor system illustrated in no. 3.

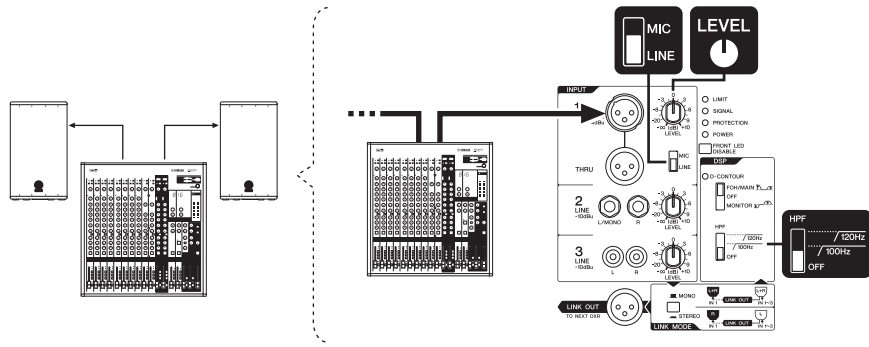

2. SR system with subwoofer

This example illustrates an SR system setup using two 2-way speakers and subwoofers with speaker poles. The system is suitable for a small-sized music venue, a house of worship and an event site. We recommend that the subwoofer's input LEVEL control is set to a 12 o'clock position. If you prefer, you can adjust the level as desired. As necessary, add a stage monitor system illustrated in no. 3.

NOTE

Pole sockets for mounting speaker poles are provided at the bottom of the DXR series, and at the top of the DXS series. Please refer to the "Precautions" (page 4).

If you use multiple subwoofers at the same time, set the POLARITY switch of adjacent subwoofers to the same position. Otherwise, the sounds from each speaker may cancel each other, resulting in diminished sound pressure.

Yamaha recommends that if you use the DSR118W as a subwoofer in combination with the DXR15 or DXR12. In this case, set HPF to 120Hz.

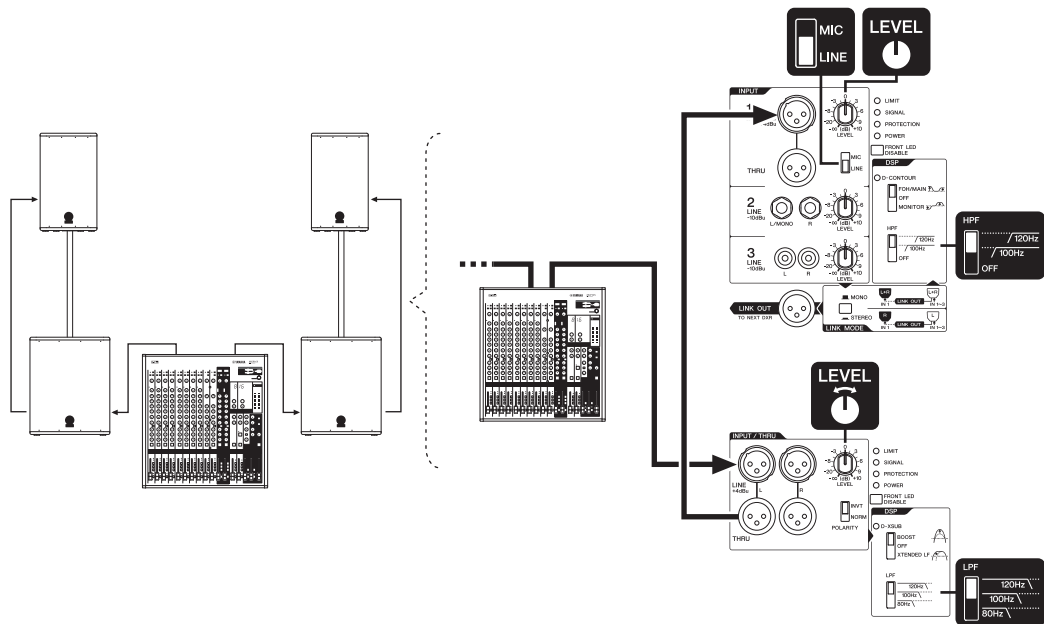

3. Stage monitor system

This SR system is suitable as a performer's monitoring system. For use as a vocal monitor, set D-CONTOUR to MONITOR. As necessary, connect speakers in parallel.

NOTE

Up to four speakers can be connected in parallel.

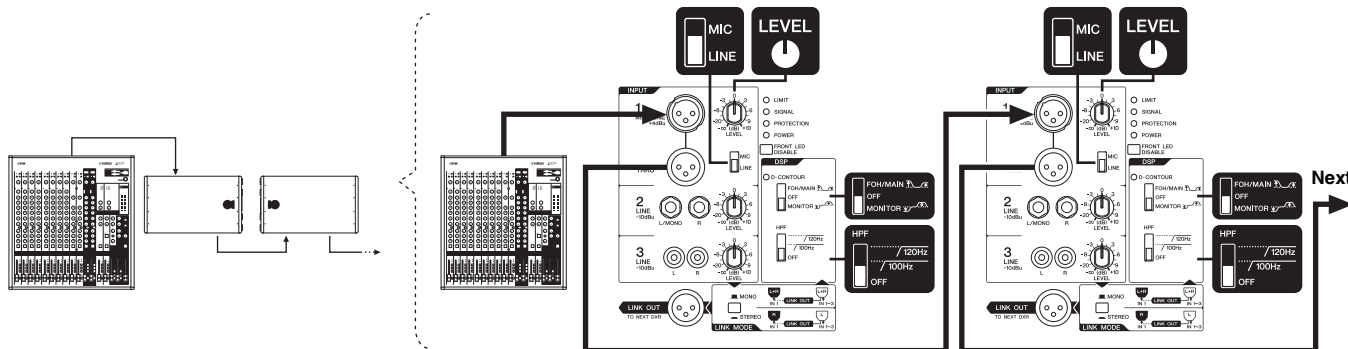

4. SR system with a single DXR

This example illustrates an SR system using one 2-way speaker connected directly to a microphone, musical instrument, or playback source. This system can be used in a wide range of places such as corporate events, presentations, and restaurants. Adjust the volume with the LEVEL control to prevent feedback.

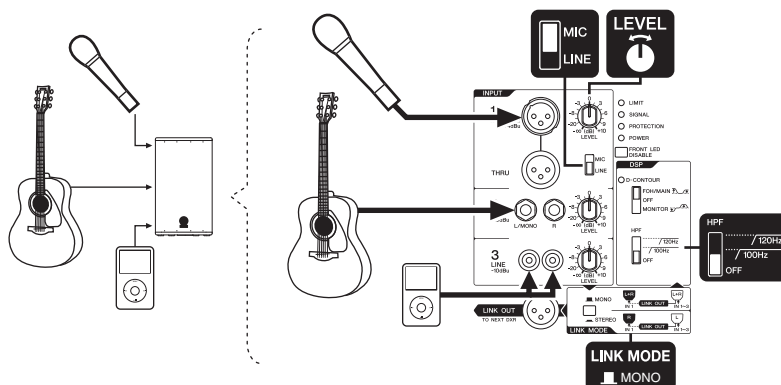

5. Simple SR system with two DXRs

This example illustrates a simple SR system using two 2-way speakers linked to each other. This system is suitable for a small-sized live venue. Audio can be output in stereo or monaural, by using one 2-way speaker connected directly to a microphone, musical instrument, or BGM sound source, then linking the speaker to another 2-way speaker via the LINK OUT jack. If you want to output in stereo, set the LINK MODE switch to the stereo position.

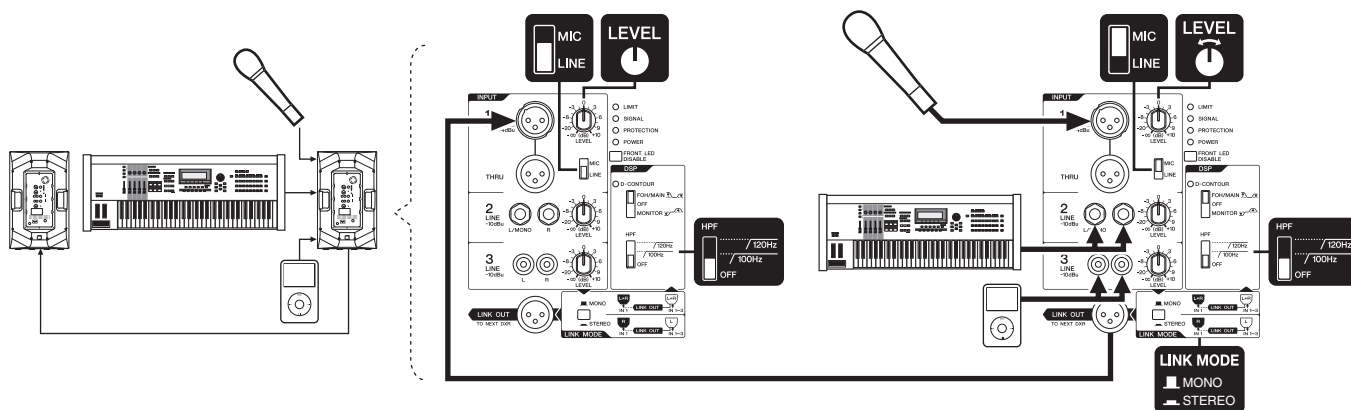

Troubleshooting

Symptom	Possible causes	Possible solution
Power does not turn on.	The power cord is not connected properly.	Connect the power cord properly.
Power suddenly went off.	The protection system has operated, shutting down the power supply.	Turn off the power, wait until the amplifier cools down, and then turn on again.
No sound.	The cable is not connected properly.	Connect to the INPUT jack properly.
	The LINK MODE switch is set incorrectly.	If you are using a single DXR, set the LINK MODE switch to MONO.
Sound is interrupted suddenly.	The protection system has operated, muting the output.	Wait until the amplifier cools down. If the device won't automatically reset itself, turn off the power, and then on again.
Sound howls (feedback)	A microphone is directed toward the speaker.	Keep the speaker away from the area where the microphone picks up sound.
	Sound is amplified too much.	Lower the volume of the input device and locate the microphone more closely to the sound source.
	The setting of the HPF switch is not appropriate.	Set the HPF switch on 120Hz or 100Hz if you get feedback in low frequency bands.
Each speaker sound differs (if multiple speakers are used)	Settings for each speaker differ.	<ul style="list-style-type: none"> • (DXR series) Set the HPF and D-CONTOUR switches of each speaker to the same positions. • (DXS series) Set the POLARITY switch, the LPF switch, and D-XSUB switch of each speaker to the same position.
Sound is distorted	Input volume is excessive.	<ul style="list-style-type: none"> • Lower the volume of the input device to a point no higher than where the LIMIT indicator lights occasionally. • If sound continues to be distorted even if you turn down the volume to the minimum, set the MIC/LINE switch to the LINE position (if the switch is set to MIC).
	Output volume is excessive.	Use the LEVEL control to lower the output level to a point no higher than where the LIMIT indicator lights occasionally.
The microphone volume is too low.	The MIC/LINE switch is set to LINE.	Set the MIC/LINE switch to the MIC position.
Low and high frequency are unbalanced.	The output limiter is active.	Lower the input level or the output level to a point no higher than where the LIMIT indicator lights occasionally.

*If any specific problem should persist, however, please contact your Yamaha dealer.

References

Specifications

General	DXR15	DXR12	DXR10	DXR8	DXS15	DXS12
System Type	2-way, Bi-amp Powered Speaker, Bass-reflex Type				Powered Subwoofer, Band-pass Type	
Frequency Range (-10dB)	49Hz – 20kHz	52Hz – 20kHz	56Hz – 20kHz	57Hz – 20kHz	45Hz – 160Hz	47Hz – 160Hz
Coverage Angle	H90° x V60° Constant Directivity Horn				–	
Crossover Type	FIR-X tuning™ (Linear Phase FIR Filter)				–	
Crossover Frequency	2.1kHz	2.1kHz	2.3kHz	2.4kHz	–	
Measured Maximum SPL (peak) IEC noise@1m	133dB SPL	132dB SPL	131dB SPL	129dB SPL	132dB SPL	131dB SPL

Transducer		DXR15	DXR12	DXR10	DXR8	DXS15	DXS12
LF	Diameter	15" Cone	12" Cone	10" Cone	8" Cone	15" Cone	12" Cone
	Voice coil	2.5"	2.5"	2"	2"	2.5"	2.5"
	Magnet	Ferrite					
HF	Diaphragm	1.4"				–	
	Type	1" Throat Compression Driver				–	
	Magnet	Ferrite				–	

Enclosure		DXR15	DXR12	DXR10	DXR8	DXS15	DXS12
Material, Finish, Color		ABS, Matte Black				Wood, Paint, Black	
Floor Monitor Angle		50° Symmetrical	50° Symmetrical	50°	–	–	
Dimensions (WxHxD, with rubber feet)		445x700x380 mm (17-1/2" x 27-1/2" x 15")	362x601x350 mm (14-1/4" x 23-5/8" x 13-3/4")	305x502x310 mm (12" x 19-3/4" x 12-1/4")	280x458x280 mm (11" x 18" x 11")	478x618x624 mm (18-7/8" x 24-3/8" x 24-1/2")	397x563x594 mm (15-5/8" x 22-1/8" x 23-3/8")
Net Weight		22.5kg (49.6lbs)	19.3kg (42.5lbs)	14.6kg (32.2lbs)	13.5kg (29.8lbs)	38.0kg (83.8lbs)	33.0kg (72.8lbs)
Handles		Aluminium die-cast (Side x 2)		Aluminium die-cast (Top x 1)		Metal (Side x 2)	
Pole Socket		35mm with 2-way feature (0 or 7 degree)				35mm (Top)	
Rigging points		Top x 2, Rear x 1 (Fits for M10 x 18mm eyebolts)		Top x 2, Rear x 1 (Fits for M8 x 15mm eyebolts)		–	
Optional Accessory (U-bracket)		UB-DXR15	UB-DXR12	UB-DXR10	UB-DXR8	–	

Amplifier		DXR15	DXR12	DXR10	DXR8	DXS15	DXS12
Amplifier Type		Class-D				Class-D	
Power Rating*1	Dynamic	1100W (LF: 950W, HF: 150W)				950W	
	Continuous	700W (LF: 600W, HF: 100W)				600W	
Cooling		Fan cooling, 4 speeds					
AD/DA		24bit 48kHz sampling					
Signal Processing		48bit (Accumulator: 76bit)					
HPF/LPF		OFF, 100, 120Hz 24dB/oct HPF				80, 100, 120Hz 24dB/oct LPF	
DSP preset		D-CONTOUR: FOH/MAIN, MONITOR, OFF				D-XSUB: BOOST, XTENDED-LF, OFF	
Protection	Speaker	Clip limiting, Integral Power Protection, DC-fault					
	Amplifier	Thermal, Output over current					
	Power supply	Thermal, Output over voltage, Output over current					
Connectors	Input	INPUT1: XLR3-31 x 1, INPUT2: Phone x 2 (Unbalanced), INPUT3: RCA PIN x 2 (Unbalanced)				INPUT: XLR3-31 x 2	
	Output	THRU: XLR3-32 x 1 (Parallel with INPUT1), LINK OUT: XLR x1				THRU: XLR3-32 x 2 (Parallel with INPUT)	
Input Impedance	INPUT1	LINE: 12kΩ, MIC: 8kΩ				10kΩ	
	INPUT2, 3	L, R: 40kΩ, MONO: 20kΩ				–	
Input Sensitivity (LEVEL: Maximum)	INPUT1	LINE: +1dBu, MIC: -32dBu				+1dBu	
	INPUT2, 3	-13dBu				–	

Amplifier		DXR15	DXR12	DXR10	DXR8	DXS15	DXS12
Input Sensitivity (LEVEL: Center)	INPUT1	LINE: +11dBu, MIC: -22dBu				+11dBu	
	INPUT2, 3	-3dBu				-	
Maximum Input Level	INPUT1	LINE: +24dBu, MIC: +20dBu				+24dBu	
	INPUT2, 3	+16dBu				-	
Controls		LEVEL x3, LINE/MIC, HPF, D-CONTOUR, FRONT LED DISABLE, LINK MODE, POWER				LEVEL, POLARITY, LPF, D-XSUB, FRONT LED DISABLE, POWER	
Idle Power Consumption		35W					
1/8 Power Consumption		110W		90W		120W	
Power Requirements		100V – 240V, 50Hz/60Hz					

0dBu is referenced to 0.775Vrms.

*1 Power rating (120V, 25°C). This is total value of individual output power.

English

Deutsch

Français

Español

Italiano

Русский

中文

日本語

Dimensions

DXR15

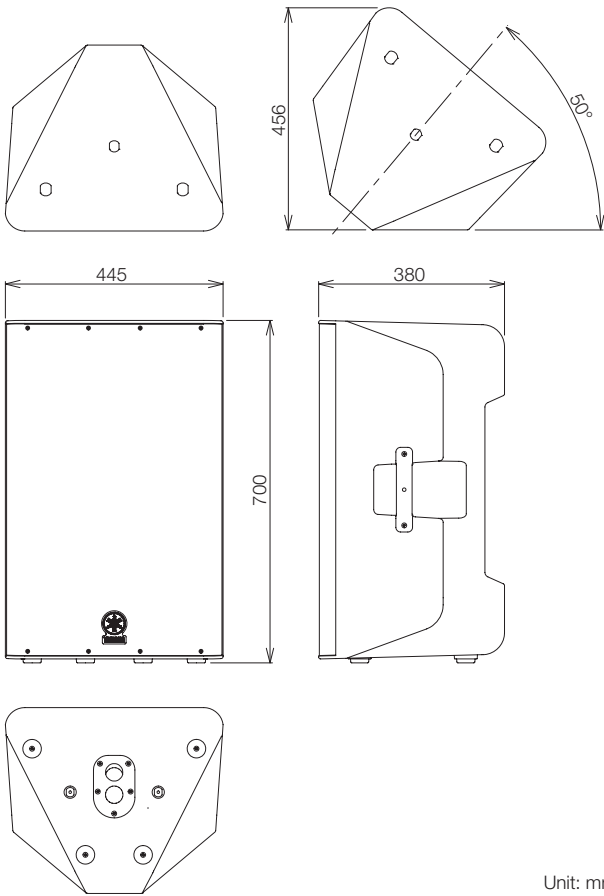

Unit: mm

DXR12

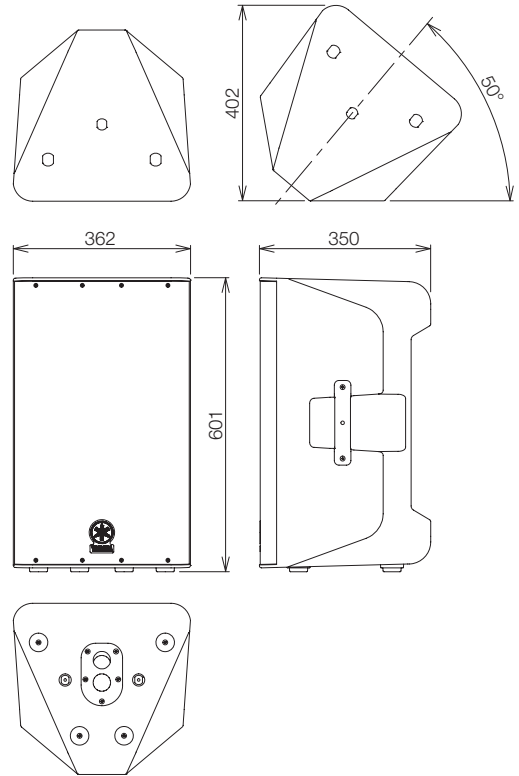

Unit: mm

DXR10

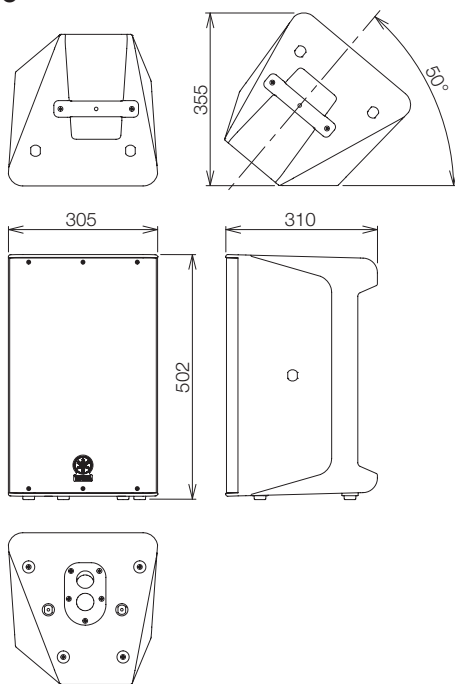

Unit: mm

DXR8

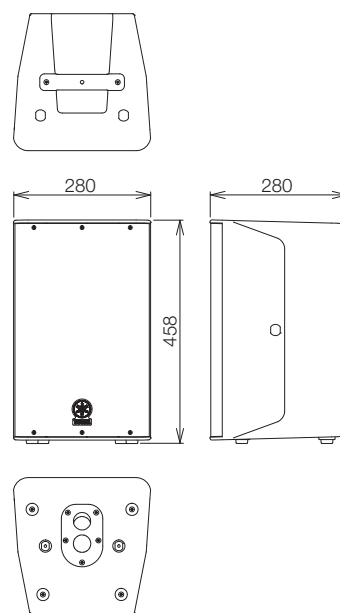

Unit: mm

- English
- Deutsch
- Français
- Español
- Italiano
- Русский
- 中文
- 日本語

DXS15

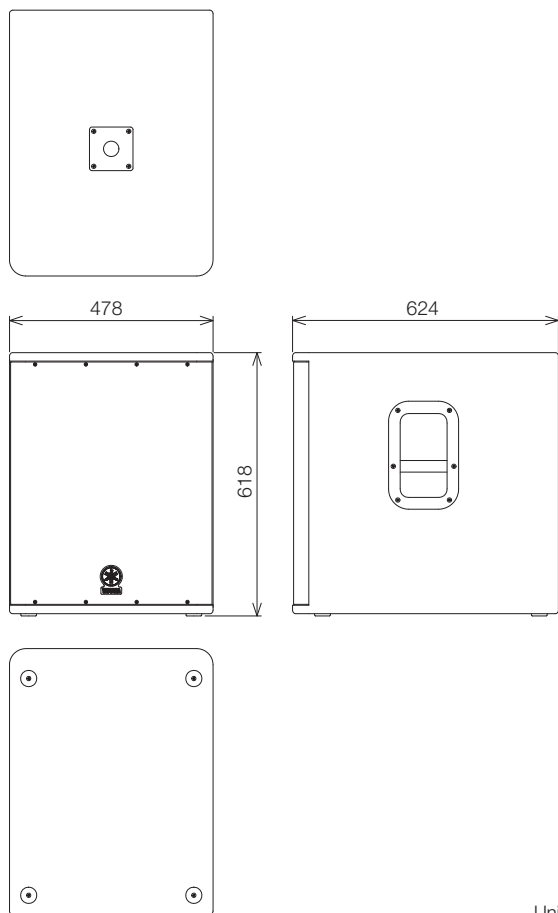

Unit: mm

DXS12

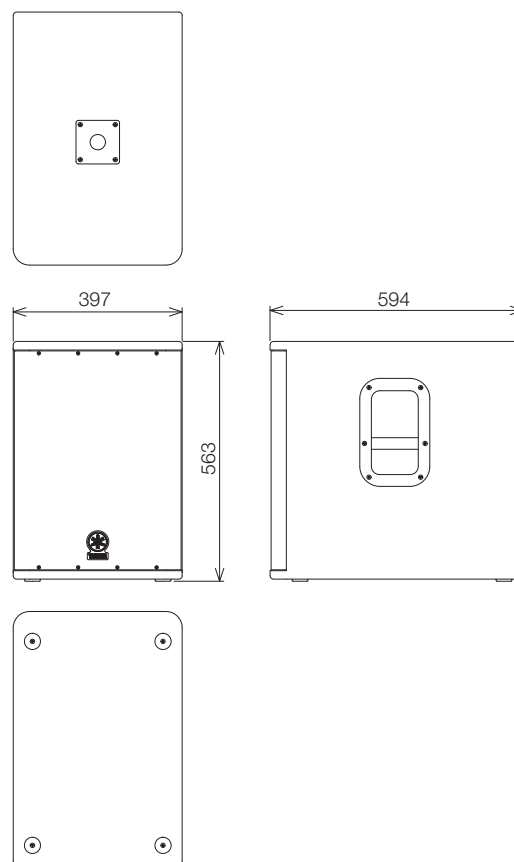

Unit: mm

English

Deutsch

Français

Español

Italiano

Русский

中文

日本語

Block Diagram

DXR block diagram

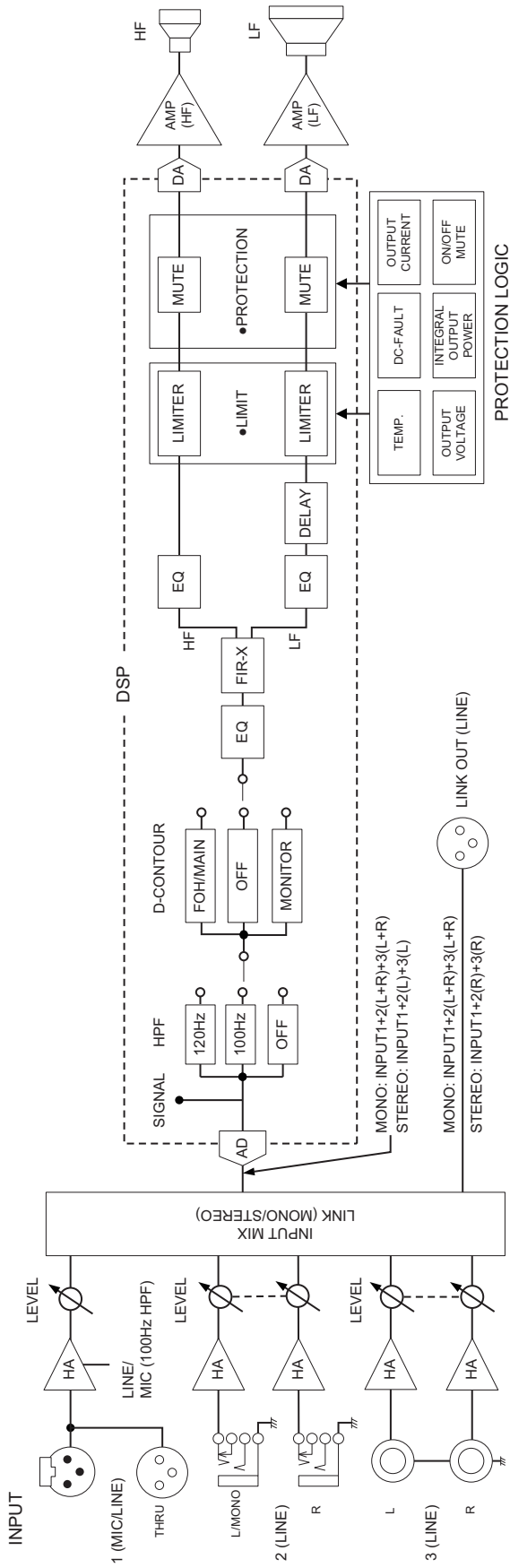

DXS block diagram

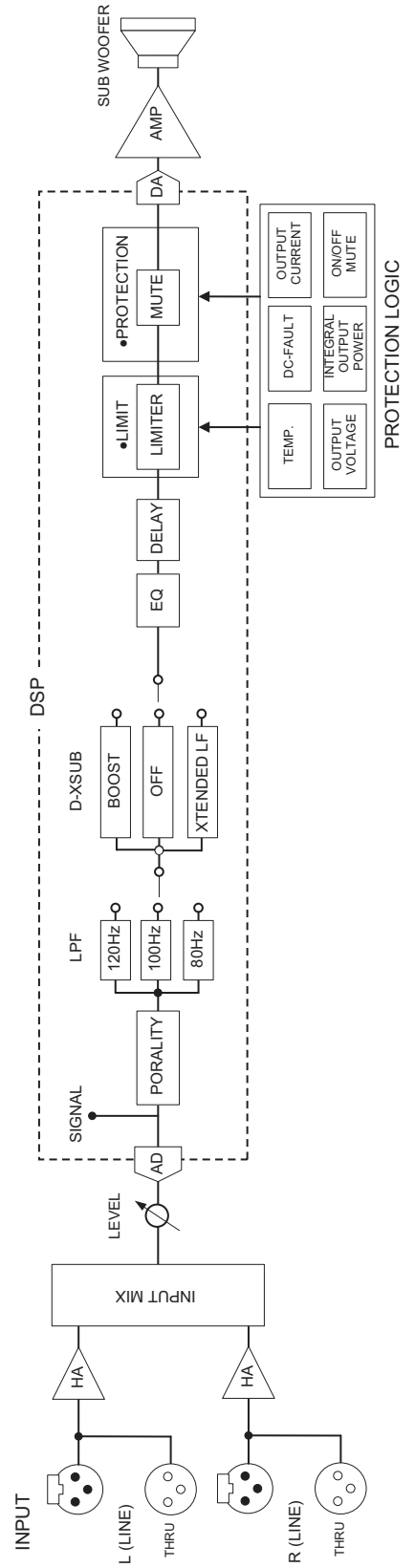

Information for Users on Collection and Disposal of Old Equipment



This symbol on the products, packaging, and/or accompanying documents means that used electrical and electronic products should not be mixed with general household waste.

For proper treatment, recovery and recycling of old products, please take them to applicable collection points, in accordance with your national legislation and the Directives 2002/96/EC.

By disposing of these products correctly, you will help to save valuable resources and prevent any potential negative effects on human health and the environment which could otherwise arise from inappropriate waste handling.

For more information about collection and recycling of old products, please contact your local municipality, your waste disposal service or the point of sale where you purchased the items.

[For business users in the European Union]

If you wish to discard electrical and electronic equipment, please contact your dealer or supplier for further information.

[Information on Disposal in other Countries outside the European Union]

This symbol is only valid in the European Union. If you wish to discard these items, please contact your local authorities or dealer and ask for the correct method of disposal.

Verbraucherinformation zur Sammlung und Entsorgung alter Elektrogeräte



Befindet sich dieses Symbol auf den Produkten, der Verpackung und/oder beiliegenden Unterlagen, so sollten benutzte elektrische Geräte nicht mit dem normalen Haushaltsabfall entsorgt werden.

In Übereinstimmung mit Ihren nationalen Bestimmungen und den Richtlinien 2002/96/EC, bringen Sie alte Geräte bitte zur fachgerechten Entsorgung, Wiederaufbereitung und Wiederverwendung zu den entsprechenden Sammelstellen.

Durch die fachgerechte Entsorgung der Elektrogeräte helfen Sie, wertvolle Ressourcen zu schützen und verhindern mögliche negative Auswirkungen auf die menschliche Gesundheit und die Umwelt, die andernfalls durch unsachgerechte Müllentsorgung auftreten könnten.

Für weitere Informationen zum Sammeln und Wiederaufbereiten alter Elektrogeräte, kontaktieren Sie bitte Ihre örtliche Stadt- oder Gemeindeverwaltung, Ihren Abfallentsorgungsdienst oder die Verkaufsstelle der Artikel.

[Information für geschäftliche Anwender in der Europäischen Union]

Wenn Sie Elektrogeräte ausrangieren möchten, kontaktieren Sie bitte Ihren Händler oder Zulieferer für weitere Informationen.

[Entsorgungsinformation für Länder außerhalb der Europäischen Union]

Dieses Symbol gilt nur innerhalb der Europäischen Union. Wenn Sie solche Artikel ausrangieren möchten, kontaktieren Sie bitte Ihre örtlichen Behörden oder Ihren Händler und fragen Sie nach der sachgerechten Entsorgungsmethode.

Information concernant la Collecte et le Traitement des déchets d'équipements électriques et électroniques.



Le symbole sur les produits, l'emballage et/ou les documents joints signifie que les produits électriques ou électroniques usagés ne doivent pas être mélangés avec les déchets domestiques habituels.

Pour un traitement, une récupération et un recyclage appropriés des déchets d'équipements électriques et électroniques, veuillez les déposer aux points de collecte prévus à cet effet, conformément à la réglementation nationale et aux Directives 2002/96/EC.

En vous débarrassant correctement des déchets d'équipements électriques et électroniques, vous contribuerez à la sauvegarde de précieuses ressources et à la prévention de potentiels effets négatifs sur la santé humaine qui pourraient advenir lors d'un traitement inapproprié des déchets.

Pour plus d'informations en propos de la collecte et du recyclage des déchets d'équipements électriques et électroniques, veuillez contacter votre municipalité, votre service de traitement des déchets ou le point de vente où vous avez acheté les produits.

[Pour les professionnels dans l'Union Européenne]

Si vous souhaitez vous débarrasser des déchets d'équipements électriques et électroniques veuillez contacter votre vendeur ou fournisseur pour plus d'informations.

[Information sur le traitement dans d'autres pays en dehors de l'Union Européenne]

Ce symbole est seulement valable dans l'Union Européenne. Si vous souhaitez vous débarrasser de déchets d'équipements électriques et électroniques, veuillez contacter les autorités locales ou votre fournisseur et demander la méthode de traitement appropriée.

Información para Usuarios sobre Recolección y Disposición de Equipamiento Viejo



Este símbolo en los productos, embalaje, y/o documentación que se acompañe significa que los productos electrónicos y eléctricos usados no deben ser mezclados con desechos hogareños corrientes.

Para el tratamiento, recuperación y reciclado apropiado de los productos viejos, por favor llévelos a puntos de recolección aplicables, de acuerdo a su legislación nacional y las directivas 2002/96/EC.

Al disponer de estos productos correctamente, ayudará a ahorrar recursos valiosos y a prevenir cualquier potencial efecto negativo sobre la salud humana y el medio ambiente, el cual podría surgir de un inapropiado manejo de los desechos.

Para mayor información sobre recolección y reciclado de productos viejos, por favor contacte a su municipio local, su servicio de gestión de residuos o el punto de venta en el cual usted adquirió los artículos.

[Para usuarios de negocios en la Unión Europea]

Si usted desea deshacerse de equipamiento eléctrico y electrónico, por favor contacte a su vendedor o proveedor para mayor información.

[Información sobre la Disposición en otros países fuera de la Unión Europea]

Este símbolo sólo es válido en la Unión Europea. Si desea deshacerse de estos artículos, por favor contacte a sus autoridades locales y pregunte por el método correcto de disposición.

Informazioni per gli utenti sulla raccolta e lo smaltimento di vecchia attrezzatura



Questo simbolo sui prodotti, sull'imballaggio, e/o sui documenti che li accompagnano significa che i prodotti elettriche e elettroniche non dovrebbero essere mischiati con i rifiuti domestici generici.

Per il trattamento, recupero e riciclaggio appropriati di vecchi prodotti, li porti, prego, ai punti di raccolta appropriati, in accordo con la Sua legislazione nazionale e le direttive 2002/96/CE.

Smaltendo correttamente questi prodotti, Lei aiuterà a salvare risorse preziose e a prevenire alcuni potenziali effetti negativi sulla salute umana e l'ambiente, che altrimenti potrebbero sorgere dal trattamento improprio dei rifiuti.

Per ulteriori informazioni sulla raccolta e il riciclaggio di vecchi prodotti, prego contatti la Sua amministrazione comunale locale, il Suo servizio di smaltimento dei rifiuti o il punto vendita dove Lei ha acquistato gli articoli.

[Per utenti imprenditori dell'Unione europea]

Se Lei desidera disfarsi di attrezzatura elettrica ed elettronica, prego contatti il Suo rivenditore o fornitore per ulteriori informazioni.

[Informazioni sullo smaltimento negli altri Paesi al di fuori dell'Unione europea]

Questo simbolo è valido solamente nell'Unione europea. Se Lei desidera disfarsi di questi articoli, prego contatti le Sue autorità locali o il rivenditore e richieda la corretta modalità di smaltimento.

Important Notice: Guarantee Information for customers in European Economic Area (EEA) and Switzerland

<p>Important Notice: Guarantee Information for customers in EEA* and Switzerland For detailed guarantee information about this Yamaha product, and Pan-EEA* and Switzerland warranty service, please either visit the website address below (Printable file is available at our website) or contact the Yamaha representative office for your country (next page). * EEA: European Economic Area</p>	<p>Suomi Tämään Yamaha-tuotteen sekä ETA-alueen ja Sveitsin takuuta koskevat yksityiskohtaiset tiedot saatte alla olevasta nettiosoitteesta. (Tuulostettava tiedosto saatavissa sivustollamme.)Voitte myös ottaa yhteyttä paikalliseen Yamaha-edustajaan (seuraavalla sivulla). *ETA: Euroopan talousalue</p>
<p>Wichtiger Hinweis: Garantie-Information für Kunden in der EWR* und der Schweiz Für nähere Garantie-Information über dieses Produkt von Yamaha, sowie über den Pan-EWR*- und Schweizer Garantieservice, besuchen Sie bitte entweder die folgende angegebene Internetadresse (eine druckfähige Version befindet sich auch auf unserer Webseite), oder wenden Sie sich an den für Ihr Land zuständigen Yamaha-Vertrieb (nächste Seite). *EWR: Europäischer Wirtschaftsraum</p>	<p>Polski Ważne: Warunki gwarancyjne obowiązujące w EOG* i Szwajcarii Aby dowiedzieć się więcej na temat warunków gwarancyjnych tego produktu firmy Yamaha i serwisu gwarancyjnego w całym EOG* i Szwajcarii, należy odwiedzić wskazaną poniżej stronę internetową (plik gotowy do wydruku do znajduje się na naszej stronie internetowej) lub skontaktować się z przedstawicielstwem firmy Yamaha w swoim kraju (następna strona). * EOG — Europejski Obszar Gospodarczy</p>
<p>Remarque importante: informations de garantie pour les clients de l'EEE et la Suisse Pour des informations plus détaillées sur la garantie de ce produit Yamaha et sur le service de garantie applicable dans l'ensemble de l'EEE ainsi qu'en Suisse, consultez notre site Web à l'adresse ci-dessous (le fichier imprimable est disponible sur notre site Web) ou contactez directement Yamaha dans votre pays de résidence (page suivante). * EEE : Espace Economique Européen</p>	<p>Česky Důležité oznámení: Záruční informace pro zákazníky v EHS* a ve Švýcarsku Podrobné záruční informace o tomto produktu Yamaha a záručním servisu v celém EHS* a ve Švýcarsku naleznete na níže uvedené webové adrese (soubor k tisku je dostupný na našich webových stránkách) nebo se můžete obrátit na zastoupení firmy Yamaha ve své zemi (další stránka). * EHS: Evropský hospodářský prostor</p>
<p>Belangrijke mededeling: Garantie-informatie voor klanten in de EER* en Zwitserland Voor gedetailleerde garantie-informatie over dit Yamaha-product en de garantieservice in heel de EER* en Zwitserland, gaat u naar de onderstaande website (u vindt een afdrukbaar bestand op onze website) of neemt u contact op met de vertegenwoordiging van Yamaha in uw land (volgende pagina). * EER: Europese Economische Ruimte</p>	<p>Magyar Fontos figyelmeztetés: Garancia-információk az EGT* területén és Svájcban élő vásárlók számára A jelen Yamaha termékre vonatkozó részletes garancia-információk, valamint az EGT*-re és Svájcra kiterjedő garanciális szolgáltatás tekintetében keresse fel webhelyünket az alábbi címen (a webhelyen nyomtatható fájl is talál), vagy pedig lépjen kapcsolatba az országában működő Yamaha képviselői irodával (következő oldal). * EGT: Európai Gazdasági Térség</p>
<p>Aviso importante: información sobre la garantía para los clientes del EEE* y Suiza Para una información detallada sobre este producto Yamaha y sobre el soporte de garantía en la zona EEE* y Suiza, visite la dirección web que se incluye mas abajo (la versión del archivo para imprimir esta disponible en nuestro sitio web) o póngase en contacto con el representante de Yamaha en su país (página siguiente). * EEE: Espacio Económico Europeo</p>	<p>Eesti keel Oluline märkus: Garantiteave Euroopa Majanduspiirkonna (EMP)* ja Šveitsi klientidele Täpsema teabe saamiseks selle Yamaha toote garantii ning kogu Euroopa Majanduspiirkonna ja Šveitsi garantiteeninduse kohta, külastage palun veebisaiti alljärgneval aadressil (meie saidil on saadaval printitav fail) või pöörduge Teie regioonil Yamaha esinduse poole (järgmine lehekülg). * EMP: Euroopa Majanduspiirkond</p>
<p>Aviso importante: informazioni sulla garanzia per i clienti residenti nell'EEA* e in Svizzera Per informazioni dettagliate sulla garanzia relativa a questo prodotto Yamaha e l'assistenza in garanzia nei paesi EEA* e in Svizzera, potete consultare il sito Web all'indirizzo riportato di seguito (è disponibile il file in formato stampabile) oppure contattate l'ufficio di rappresentanza locale della Yamaha (pagina seguente). * EEA: Area Economica Europea</p>	<p>Latviešu Svarīgs paziņojums: garantijas informācija klientiem EEZ* un Šveicā Lai saņemtu detalizētu garantijas informāciju par šo Yamaha produktu, kā arī garantijas apkalpošanu EEZ* un Šveicā, lūdzu, apmeklējiet zemāk norādīto tīmekļa vietnes adresi (tīmekļa vietnē ir pieejams drukājams fails) vai sazinieties ar jūsu valsti apkalpojošo Yamaha pārstāvniecību (nākamā lappuse). * EEZ: Eiropas Ekonomikas zona</p>
<p>Aviso importante: informações sobre as garantias para clientes da AEE* e da Suíça Para obter uma informação pormenorizada sobre este produto da Yamaha e sobre o serviço de garantia na AEE* e na Suíça, visite o site a seguir (o arquivo para impressão está disponível no nosso site) ou entre em contato com o escritório de representação da Yamaha no seu país (próxima página). * AEE: Área Económica Europeia</p>	<p>Lietuvių kalba Dėmesio: informacija dėl garantijos priekšams EEE* ir Šveicarijoje Jei reikia išsamios informacijos apie šį „Yamaha“ produktą ir jo techninę priežiūrą visoje EEE* ir Šveicarijoje, apsilankykite mūsų svetainėje toliau nurodytu adresu (svetainėje yra spausdintinas failas) arba kreipkitės į „Yamaha“ atstovybę savo šaliai (kitas puslapis). *EEE – Europos ekonominė erdvė</p>
<p>Σημαντική σημείωση: Πληροφορίες εγγύησης για τους πελάτες στον ΕΟΧ* και Ελβετία Για λεπτομερείς πληροφορίες εγγύησης σχετικά με το προϊόν της Yamaha και την κάλυψη εγγύησης σε όλες τις χώρες του ΕΟΧ* και την Ελβετία, επισκεφτείτε την παρακάτω ιστοσελίδα (Εκτυπώσιμη μορφή είναι διαθέσιμη στην ιστοσελίδα μας) ή απευθυνθείτε στην αντιπροσωπεία της Yamaha στη χώρα σας (επόμενη σελίδα). * ΕΟΧ: Ευρωπαϊκός Οικονομικός Χώρος</p>	<p>Slovenčina Dôležité upozornenie: Informácie o záruke pre zákazníkov v EHP* a Švajčiarsku Podrobne informácie o záruke týkajúce sa tohto produktu od spoločnosti Yamaha a garancnom servise v EHP* a Švajčiarsku nájdete na webovej stránke uvedenej nižšie (na našej webovej stránke je k dispozícii súbor na tlač) alebo sa obráťte na zástupcu spoločnosti Yamaha vo svojej krajine (nasledujúca strana). * EHP: Európsky hospodársky priestor</p>
<p>Viktigt: Garantinformasjon for kunder i EES-området* och Schweiz För detaljerad information om denna Yamahaprodukt samt Garantieservice i hela EES-området* och Schweiz kan du antingen besöka nedanstående webbadress (en utskriftsvänlig fil finns på webbplatsen) eller kontakta Yamahas officiella representant i ditt land (nästa sida). * EES: Europeiska Ekonomiska Samarbetsområdet</p>	<p>Slovenščina Pomembno obvestilo: Informacije o garanciji za kupce v EGP* in Švici Za podrobnejše informacije o tem Yamahini izdelku ter garancijskem servisu v celotnem EGP in Švici, obiščite spletno mesto, ki je navedeno spodaj (natisljiva datoteka je na voljo na našem spletnem mestu), ali se obrnite na Yamahinega predstavnik v svoji državi (naslednja stran). * EGP: Evropski gospodarski prostor</p>
<p>Viktig merknad: Garantinformasjon for kunder i EØS* og Sveits Detaljert garantinformasjon om dette Yamaha-produktet og garantieservice for hele EØS-området* og Sveits kan fås enten ved å besøke nettstedene nedenfor (utskriftsversjonen finnes på våre nettsider) eller kontakte kontakte Yamaha-kontoret i landet der du bor (neste side). * EØS: Det europeiske økonomiske samarbeidsområdet</p>	<p>Български език Важно съобщение: Информация за гаранцията за клиенти в ЕИП* и Швейцария За подробна информация за гаранцията за този продукт на Yamaha и гаранционното обслужване в паневропейската зона на ЕИП* и Швейцария или посетете посочения по-долу уеб сайт (на нашия уеб сайт има файл за печат), или се свържете с представителния офис на Yamaha във вашата страна (следваща страница). * ЕИП: Европейско икономическо пространство</p>
<p>Vigtig oplysning: Garantoplysninger til kunder i EØO* og Schweiz De kan finde detaljerede garantiplysninger om dette Yamaha-produkt og den fælles garantiserviceordning for EØO* (og Schweiz) ved at besøge det websted, der er angivet nedenfor (der findes en fil, som kan udskrives, på vores websted), eller ved at kontakte Yamahas nationale repræsentationskontor i det land, hvor De bor (næste side). * EØO: Det Europæiske Økonomiske Område</p>	<p>Limba română Notificare importantă: Informații despre garanție pentru clienții din SEE* și Elveția Pentru informații detaliate privind acest produs Yamaha și serviciul de garanție Pan-SEE* și Elveția, vizitați site-ul la adresa de mai jos (fișierul imprimabil este disponibil pe site-ul nostru) sau contactați biroul reprezentanței Yamaha din țara dumneavoastră (pagina următoare). * SEE: Spațiul Economic European</p>

<http://europe.yamaha.com/warranty/>

Yamaha Representative Offices in Europe

AUSTRIA

Yamaha Music Europe GmbH
Branch Austria
Schleiergasse 20, A-1100 Wien Austria
Tel: +43 (0)1 602 03900
Fax: +43 (0)1 602 039051

BELGIUM

Yamaha Music Europe
Branch Benelux
Clarissenhof 5b NL, 4133 AB. Vianen
The Netherlands
Tel: +31 (0)347 358040
Fax: +31 (0)347 358060

BULGARIA

Yamaha Music Europe GmbH
Branch Austria (Central and Eastern Europe)
Schleiergasse 20, A-1100 Wien Austria
Tel: +43 (0)1 602 03900
Fax: +43 (0)1 602 039051

CYPRUS

NAKAS Music Cyprus Ltd.
31C Nikis Ave., 1086 Nicosia
Tel: +357 (0)22 510 477
Fax: +357 (0)22 511 080

CZECH REPUBLIC

Yamaha Music Europe GmbH
Branch Austria (Central and Eastern Europe)
Schleiergasse 20, A-1100 Wien Austria
Tel: +43 (0)1 602 03900
Fax: +43 (0)1 602 039051

DENMARK

Y'S Copenhagen Liaison Office
(Yamaha Scandinavia AB Filial Denmark)
Generatorvej 6A, 2730 Herlev, Denmark
Tel: +45 44 92 49 00
Fax: +45 44 54 47 09

ESTONIA

Yamaha Music Europe GmbH
Sp. z o.o. Oddział w Polsce
(Branch Poland)
ul. 17 Stycznia 56
PL-02-146 Warszawa Poland
Tel: +48 (0)22 500 29 25
Fax: +48 (0)22 500 29 30

FINLAND

(For Musical Instrument)
F - Musiikki OY
Kaisaniemenkatu 7, PL260
00101 Helsinki, Finland
Tel: +358 (0)9 618511
Fax: +358 (0)9 61851385

(For Pro Audio)

Yamaha Scandinavia AB
Yamaha Scandinavia AB
J A Wettergrens gata 1
Västra Frölunda, Sweden
(Box 300 53, 400 43 Goteborg
Sweden - Postal Address)
Tel: +46 (0)31 893400
Fax: +46 (0)31 454026

FRANCE

Yamaha Musique France
Zone d'activité de Parifest
7, rue Ambroise Croizat
77183 Croissy-Beaubourg, France
(B.P. 70, 77312 Mame la Vallée Cedex 2
France-Adresse postale)
Tel: +33 (0)1 64 61 4000
Fax: +33 (0)1 64 61 4079

GERMANY

Yamaha Music Europe GmbH
Siemensstr 22-34
D-25462 Rellingen, b. Hamburg, Germany
Tel: +49 (0)4101 3030
Fax: +49 (0)4101 303 77702

GREECE

PH. Nakas S.A.Music House/Service
19 KM Leoforos Lavriou
19002 Peania / Attiki, Greece
Tel: +30 (0)210 6686260
Fax: +30 (0)210 6686269

HUNGARY

Yamaha Music Europe GmbH
Branch Austria (Central and Eastern Europe)
Schleiergasse 20, A-1100 Wien Austria
Tel: +43 (0)1 602 03900
Fax: +43 (0)1 602 039051

ICELAND

(For Musical Instrument)
HLJODFAERAHUSID EHF
Sidumula 20
108 Reykjavik, Iceland
Tel: +354 525 50 50
Fax: +354 568 65 14

(For Pro Audio)

Yamaha Scandinavia AB
Yamaha Scandinavia AB
J A Wettergrens gata 1
Västra Frölunda, Sweden
(Box 300 53, 400 43 Goteborg
Sweden - Postal Address)
Tel: +46 (0)31 893400
Fax: +46 (0)31 454026

IRELAND (REPUBLIC OF IRELAND)

Yamaha Music UK Ltd.
Sherbourne Drive
Tilbrook, Milton Keynes MK7 8BL
United Kingdom
Tel: +353 (0) 1526 2449
Fax: +44 (0) 1908 369278

ITALY

Yamaha Musica Italia s.p.a.
Viale Italia 88
20020, Lainate (Milano), Italy
Tel: +39 (0)02 93577 1
Fax: +39 (0)02 937 0956

LATVIA

Yamaha Music Europe GmbH
(Branch Poland)
ul. 17 Stycznia 56
PL-02-146 Warszawa Poland
Tel: +48 (0)22 500 29 25
Fax: +48 (0)22 500 29 30

LIECHTENSTEIN

Yamaha Music Europe GmbH, Rellingen,
Branch Switzerland in Zurich
Seefeldstrasse 94, CH-8008
Zürich, Switzerland
Tel: +41 (0)44 3878080
Fax: +41 (0)44 3833918

LITHUANIA

Yamaha Music Europe GmbH
Sp. z o.o. Oddział w Polsce
(Branch Poland)
ul. 17 Stycznia 56
PL-02-146 Warszawa Poland
Tel: +48 (0)22 500 29 25
Fax: +48 (0)22 500 29 30

LUXEMBOURG

Yamaha Music Europe
Branch Benelux
Clarissenhof 5b NL, 4133 AB. Vianen
The Netherlands
Tel: +31 (0)347 358040
Fax: +31 (0)347 358060

MALTA

Olimpus Music Ltd.
The Emporium, Level 3, St. Louis Street
Msida MSD06
Tel: +356 (0)2133 2093
Fax: +356 (0)2133 2144

NETHERLANDS

Yamaha Music Europe
Branch Benelux
Clarissenhof 5b NL, 4133 AB. Vianen
The Netherlands
Tel: +31 (0)347 358040
Fax: +31 (0)347 358060

NORWAY

Y'S Oslo Liaison Office
(Yamaha Scandinavia AB Filial Norway)
Grini Naeringspark 1
1361 Osteras, Norway
Tel: +47 67 16 77 70
Fax: +47 67 16 77 79

POLAND

YAMAHA Music Europe GmbH
Sp. z o.o. Oddział w Polsce
ul. 17 Stycznia 56
02-146 WARSZAWA/POLSKA
Tel: +48 (0)22 500 29 25
Fax: +48 (0)22 500 29 30

PORTUGAL

Yamaha Música Ibérica, S.A.U.
Sucursal Portuguesa
Rua Alfredo da Silva
2610-016 Amadora, Portugal
Tel: +351 214 704 330
Fax: +351 214 718 220

ROMANIA

Yamaha Music Europe GmbH
Branch Austria (Central and Eastern Europe)
Schleiergasse 20, A-1100 Wien Austria
Tel: +43 (0)1 602 03900
Fax: +43 (0)1 602 039051

SLOVAKIA

Yamaha Music Europe GmbH
Branch Austria (Central and Eastern Europe)
Schleiergasse 20, A-1100 Wien Austria
Tel: +43 (0)1 602 03900
Fax: +43 (0)1 602 039051

SLOVENIA

Yamaha Music Europe GmbH
Branch Austria (Central and Eastern Europe)
Schleiergasse 20, A-1100 Wien Austria
Tel: +43 (0)1 602 03900
Fax: +43 (0)1 602 039051

SPAIN

Yamaha Música Ibérica, S.A.U.
Ctra. de la Coruna km.17, 200
28230 Las Rozas de Madrid, Spain
Tel: +34 902 39 8888
Fax: +34 91 638 4660

SWEDEN

Yamaha Scandinavia AB
J A Wettergrens gata 1
Västra Frölunda, Sweden
(Box 300 53, 400 43 Goteborg
Sweden - Postal Address)
Tel: +46 (0)31 893400
Fax: +46 (0)31 454026

SWITZERLAND

Yamaha Music Europe GmbH, Rellingen,
Branch Switzerland in Zurich
Seefeldstrasse 94, CH-8008
Zürich, Switzerland
Tel: +41 (0)44 3878080
Fax: +41 (0)44 3833918

UNITED KINGDOM

Yamaha Music UK Ltd.
Sherbourne Drive
Tilbrook, Milton Keynes MK7 8BL
United Kingdom
Tel: +44 (0) 870 4445575
Fax: +44 (0) 1908 369278

For details of products, please contact your nearest Yamaha representative or the authorized distributor listed below.

Pour plus de détails sur les produits, veuillez-vous adresser à Yamaha ou au distributeur le plus proche de vous figurant dans la liste suivante.

Die Einzelheiten zu Produkten sind bei Ihrer unten aufgeführten Niederlassung und bei Yamaha Vertragshändlern in den jeweiligen Bestimmungsländern erhältlich.

Para detalles sobre productos, contacte su tienda Yamaha más cercana o el distribuidor autorizado que se lista debajo.

NORTH AMERICA

CANADA

Yamaha Canada Music Ltd.
135 Milner Avenue, Scarborough, Ontario,
M1S 3R1, Canada
Tel: 416-298-1311

U.S.A.

Yamaha Corporation of America
6600 Orangethorpe Ave., Buena Park, Calif. 90620,
U.S.A.
Tel: 714-522-9011

CENTRAL & SOUTH AMERICA

MEXICO

Yamaha de México S.A. de C.V.
Calz. Javier Rojo Gómez #1149,
Col. Guadalupe del Moral
C.P. 09300, México, D.F., México
Tel: 55-5804-0600

BRAZIL

Yamaha Musical do Brasil Ltda.
Rua Joaquim Floriano, 913 - 4º andar, Itaim Bibi,
CEP 04534-013 Sao Paulo, SP. BRAZIL
Tel: 011-3704-1377

ARGENTINA

**Yamaha Music Latin America, S.A.
Sucursal de Argentina**
Olga Cossetini 1553, Piso 4 Norte
Madero Este-C1107CEK
Buenos Aires, Argentina
Tel: 011-4119-7000

PANAMA AND OTHER LATIN AMERICAN COUNTRIES/ CARIBBEAN COUNTRIES

Yamaha Music Latin America, S.A.
Torre Banco General, Piso 7, Urbanización Marbella,
Calle 47 y Aquilino de la Guardia,
Ciudad de Panamá, Panamá
Tel: +507-269-5311

EUROPE

THE UNITED KINGDOM/IRELAND

Yamaha Music Europe GmbH (UK)
Sherbourne Drive, Tilbrook, Milton Keynes,
MK7 8BL, England
Tel: 01908-366700

GERMANY

Yamaha Music Europe GmbH
Siemensstraße 22-34, 25462 Rellingen, Germany
Tel: 04101-3030

SWITZERLAND/LIECHTENSTEIN

**Yamaha Music Europe GmbH
Branch Switzerland in Zürich**
Seefeldstrasse 94, 8008 Zürich, Switzerland
Tel: 044-387-8080

AUSTRIA/BULGARIA

Yamaha Music Europe GmbH Branch Austria
Schleiergasse 20, A-1100 Wien, Austria
Tel: 01-60203900

CZECH REPUBLIC/HUNGARY/ ROMANIA/SLOVAKIA/SLOVENIA

**Yamaha Music Europe GmbH
Branch Austria (Central Eastern Europe Office)**
Schleiergasse 20, A-1100 Wien, Austria
Tel: 01-602039025

POLAND/LITHUANIA/LATVIA/ESTONIA

**Yamaha Music Europe GmbH
Branch Sp.z o.o. Oddział w Polsce**
ul. 17 Stycznia 56, PL-02-146 Warszawa, Poland
Tel: 022-500-2925

MARTA

Olimpus Music Ltd.
The Emporium, Level 3, St. Louis Street Msida
MSD06
Tel: 02133-2144

THE NETHERLANDS/ BELGIUM/LUXEMBOURG

Yamaha Music Europe Branch Benelux
Clarissenhof 5-b, 4133 AB Vianen, The Netherlands
Tel: 0347-358 040

FRANCE

Yamaha Music Europe
BP 70-77312 Marne-la-Vallée Cedex 2, France
Tel: 01-64-61-4000

ITALY

Yamaha Music Europe GmbH, Branch Italy
Viale Italia 88, 20020 Lainate (Milano), Italy
Tel: 02-935-771

SPAIN/PORTUGAL

**Yamaha Music Europe GmbH Ibérica, Sucursal
en España**
Ctra. de la Coruna km. 17, 200, 28230
Las Rozas (Madrid), Spain
Tel: +34-902-39-8888

GREECE

Philippos Nakas S.A. The Music House
147 Skiathou Street, 112-55 Athens, Greece
Tel: 01-228 2160

SWEDEN/FINLAND/ICELAND

**Yamaha Music Europe GmbH Germany filial
Scandinavia**
J. A. Wettergrens Gata 1, Box 30053
S-400 43 Göteborg, Sweden
Tel: 031 89 34 00

DENMARK

**Yamaha Music Europe GmbH, Tyskland – filial
Denmark**
Generatorvej 6A, DK-2730 Herlev, Denmark
Tel: 44 92 49 00

NORWAY

**Yamaha Music Europe GmbH Germany -
Norwegian Branch**
Grini Næringspark 1, N-1345 Østerås, Norway
Tel: 67 16 77 70

RUSSIA

Yamaha Music (Russia)
Room 37, bld. 7, Kievskaya street, Moscow,
121059, Russia
Tel: 495 626 5005

OTHER EUROPEAN COUNTRIES

Yamaha Music Europe GmbH
Siemensstraße 22-34, 25462 Rellingen, Germany
Tel: +49-4101-3030

AFRICA

**Yamaha Corporation,
Asia-Pacific Sales & Marketing Group**
Nakazawa-cho 10-1, Naka-ku, Hamamatsu,
Japan 430-8650
Tel: +81-53-460-2303

MIDDLE EAST

TURKEY/CYPRUS

Yamaha Music Europe GmbH
Siemensstraße 22-34, 25462 Rellingen, Germany
Tel: 04101-3030

OTHER COUNTRIES

Yamaha Music Gulf FZE
LOB 16-513, P.O.Box 17328, Jubel Ali,
Dubai, United Arab Emirates
Tel: +971-4-881-5868

ASIA

THE PEOPLE'S REPUBLIC OF CHINA

Yamaha Music & Electronics (China) Co., Ltd.
2F, Yunhedasha, 1818 Xinzha-lu, Jingan-qu,
Shanghai, China
Tel: 021-6247-2211

INDIA

Yamaha Music India Pvt. Ltd.
5F Ambience Corporate Tower Ambience Mall Complex
Ambience Island, NH-8, Gurgaon-122001, Haryana, India
Tel: 0124-466-5551

INDONESIA

PT. Yamaha Musik Indonesia (Distributor)

PT. Nusantara
Gedung Yamaha Music Center, Jalan Jend. Gatot
Subroto Kav. 4, Jakarta 12930, Indonesia
Tel: 021-520-2577

KOREA

Yamaha Music Korea Ltd.
8F, 9F, Dongsung Bldg. 158-9 Samsung-Dong,
Kangnam-Gu, Seoul, Korea
Tel: 02-3467-3300

MALAYSIA

Yamaha Music (Malaysia) Sdn., Bhd.
Lot 8, Jalan Perbandaran, 47301 Kelana Jaya,
Petaling Jaya, Selangor, Malaysia
Tel: 03-78030900

SINGAPORE

Yamaha Music (Asia) Pte., Ltd.
#03-11 A-Z Building
140 Paya Lebor Road, Singapore 409015
Tel: 6747-4374

TAIWAN

Yamaha KHS Music Co., Ltd.
3F, #6, Sec.2, Nan Jing E. Rd. Taipei.
Taiwan 104, R.O.C.
Tel: 02-2511-8688

THAILAND

Siam Music Yamaha Co., Ltd.
4, 6, 15 and 16th floor, Siam Motors Building,
891/1 Rama 1 Road, Wangmai,
Pathumwan, Bangkok 10330, Thailand
Tel: 02-215-2622

OTHER ASIAN COUNTRIES

**Yamaha Corporation,
Asia-Pacific Sales & Marketing Group**
Nakazawa-cho 10-1, Naka-ku, Hamamatsu,
Japan 430-8650
Tel: +81-53-460-2303

OCEANIA

AUSTRALIA

Yamaha Music Australia Pty. Ltd.
Level 1, 99 Queensbridge Street, Southbank,
Victoria 3006, Australia
Tel: 3-9693-5111

COUNTRIES AND TRUST TERRITORIES IN PACIFIC OCEAN

**Yamaha Corporation,
Asia-Pacific Sales & Marketing Group**
Nakazawa-cho 10-1, Naka-ku, Hamamatsu,
Japan 430-8650
Tel: +81-53-460-2303



Yamaha Pro Audio global website
<http://www.yamahaproaudio.com/>

Yamaha Manual Library
<http://www.yamaha.co.jp/manual/>

C.S.G., Pro Audio Division
© 2011 Yamaha Corporation
111MWCR*. *-**B0
Printed in China

ZA97860