

## Overview

---

Low-profile ceiling speakers designed for superior music reproduction



## Features

---

- Series offers different woofer sizes in either black or white.
- Engineered for optimum BGM reproduction.
- Wide coverage allows a single speaker to cover a wide area.
- Designed with optimized bass-reflex tuning to offer a firm, tight low-end.
- Low-profile design facilitates installation in limited ceiling spaces: A back can with only 76mm (3.0") depth.
- Equipped with internal transformers that allow both high and low impedance drive, which can be selected by simply switching the tap on the baffle.
- A flexible carrying band makes the speakers very portable and allows carrying multiple speakers at once.
- Overload protection circuit provided to protect speaker components.
- Comes with paintable speaker grilles for flexible design ideas.

## Specifications

### General Specifications

Speaker Type		Full range, Bass reflex
Frequency Range (-10dB)		67 Hz - 20 kHz (Half-space 2 $\pi$ )
Nominal Coverage		160°conical (Half-space 2 $\pi$ )
Components	LF-HF	2.5" Full range unit
Power Rating	NOISE	15 W
	PGM	30 W
	PEAK	60 W
Nominal Impedance		8 $\Omega$
Transformer Taps	100V	15 W, 7.5 W, 3.8 W, 1.9 W
	70V	15 W, 7.5 W, 3.8 W, 1.9 W, 1 W
SPL	Sensitivity (1W; 1m on axis)	86 dB SPL (Half-space 2 $\pi$ )
	Peak (Calculated)	104 dB SPL (Calculated, 1m)
I/O Connectors		Euroblock (4 pin) $\times$ 1 (input: +/-, loop-thru: +/-)
Protection Circuit	Load Protection	Full-range power limiting to protect network and transducers
Finish		VXC2FB: Black (approx. Munsell N3), VXC2FW: White (approx. Munsell N9.3)
Dimensions	Diameter	225 mm (8-7/8")
	D	89 mm (3-1/2")
Net Weight		1.7 kg (3.7 lbs)
Cutout Size		$\varnothing$ 186 mm ( $\varnothing$ 7-5/16")
Required Ceiling Board Thickness		5 mm – 37 mm
Accessories		Cutout Template
Packaging		Single package
Certificate		UL1480, UL2043, NFPA70, CE, EAC, RoHS
EN54-24 Compliance		-
Others		Conduit tube: $\varnothing$ 15.4 mm - $\varnothing$ 21.3 mm
Options		PK-C4B / PK-C4W: Pendant-mount kit, AB-C2: C-ring + Tile Rail kit

**Dimensions**

Unit: mm (inch)

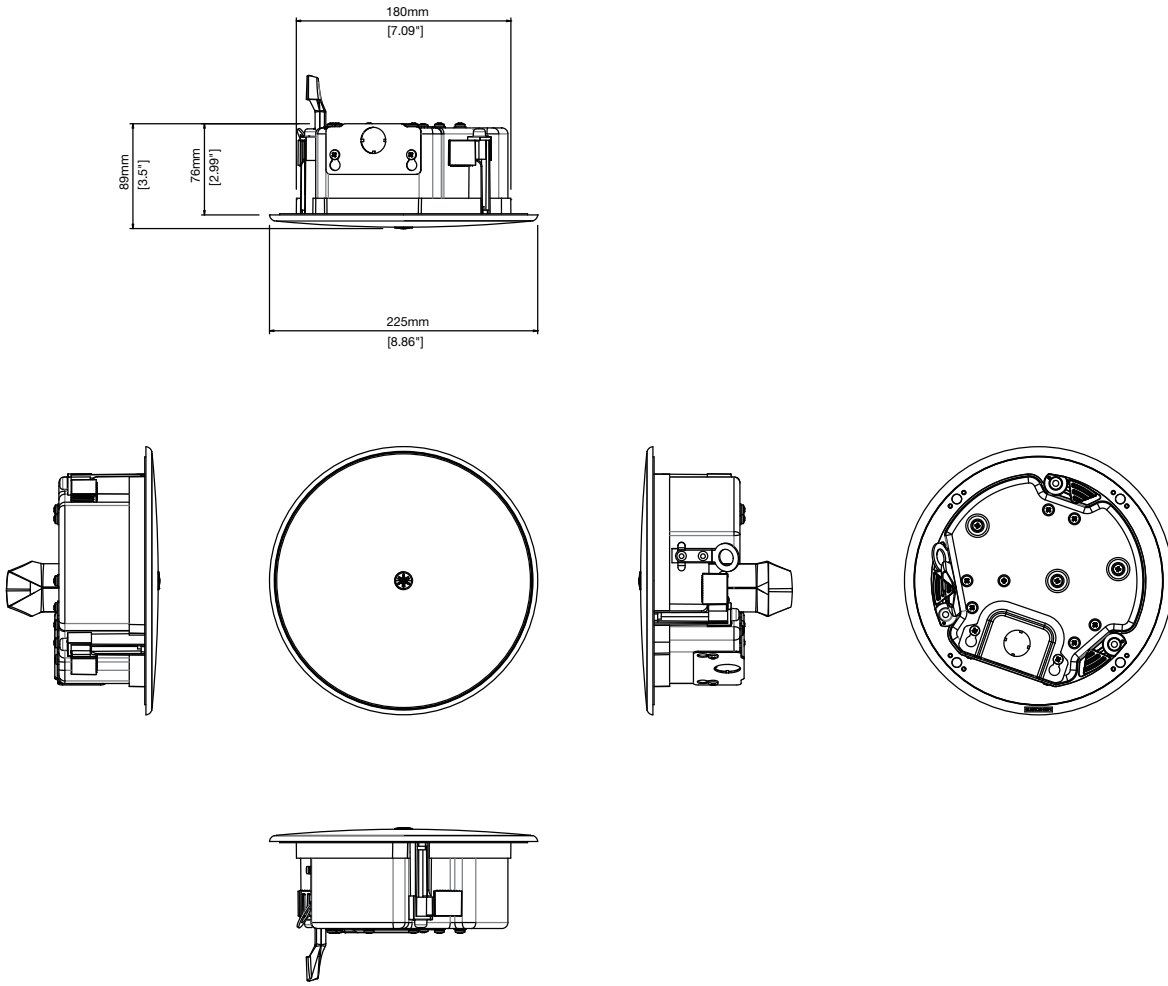

**Option : AB-C2**

**Tile Rail**

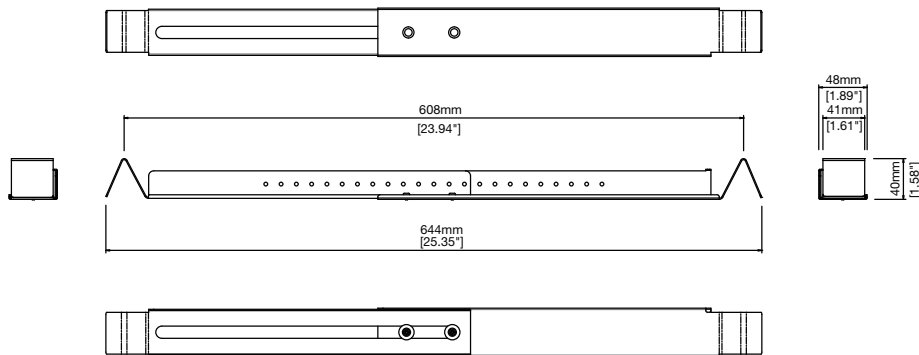

**C-ring**

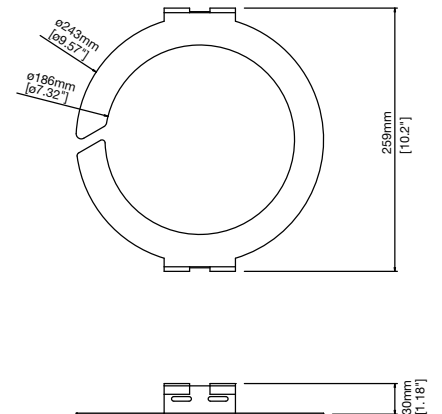

## Architectural and Engineering Specifications

---

The loudspeaker shall be of in-ceiling design, a full-range bass-reflex type and shall have a back can. The loudspeaker shall consist of a 2.5" (6.35cm) cone driver. The loudspeaker shall be equipped with internal transformers that allow both high-impedance and low-impedance drive. The flexible carrying band shall be provided for improved portability. The power rating shall be set by switching a transformer tap on the baffle as follows: 15W/7.5W/3.8W/1.9W in 100V line; 15W/7.5W/3.8W/1.9W/1W in 70V line; and 30W into 8 ohms. The loudspeaker shall be capable of meeting the following performance criteria: The measured sensitivity shall be 86dB SPL (at 1W, 1m, in half-space); The maximum SPL shall be 104dB SPL (at 1m); The frequency range shall be 67Hz-20kHz (10dB below rated sensitivity, in half-space); The nominal coverage angle shall be 160° polar conical. The loudspeaker shall be provided for an overload protection circuit to protect network and transducers. The 4-pin Euroblock connector shall be provided for an input and a loop-thru. The grille shall have the following color variation: black-painted (VXC2FB) or white-painted (VXC2FW). Overall front face diameter of the loudspeaker shall not exceed 225mm (8.85"), overall depth from the bottom of the ceiling shall not exceed 89mm (3.5"), a back can depth shall not exceed 76mm (3.0"), and shall weigh no more than 1.7kg (3.7lbs). The loudspeaker shall have optional accessories as follows: The O-rings and the tile rails shall be prepared for safer and smoother installation. The loudspeaker shall be the Yamaha VXC2FB or VXC2FW.

## Sensitivity

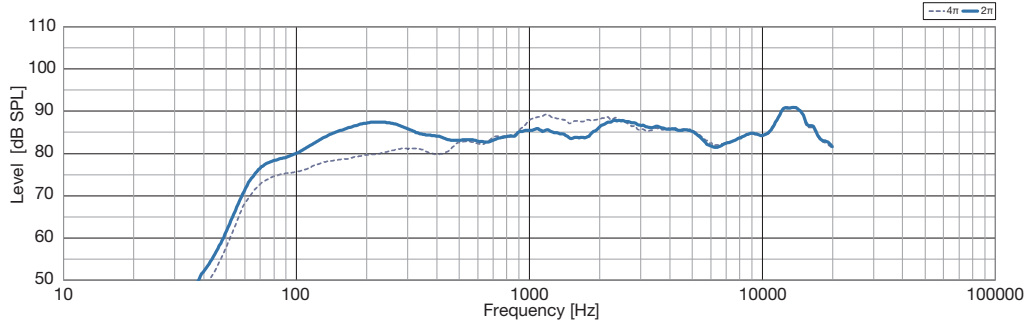

## Beamwidth

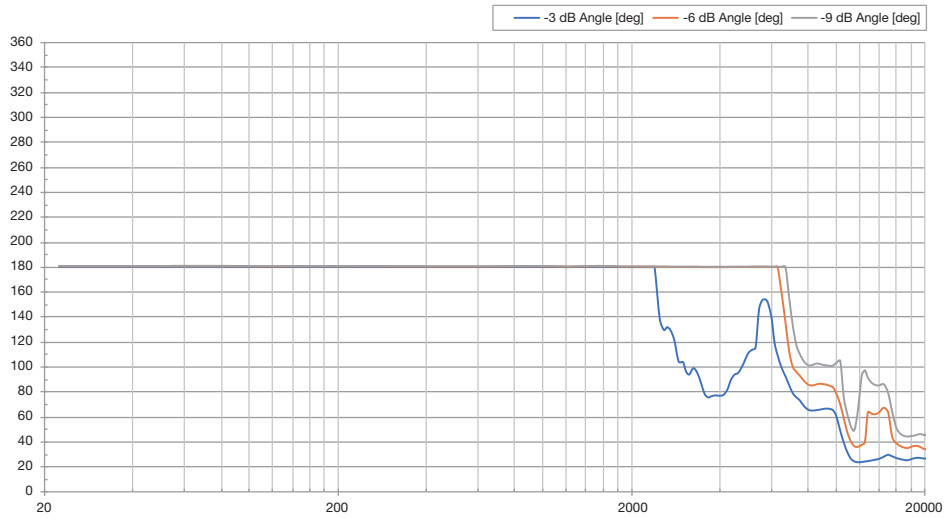

## Directivity Index

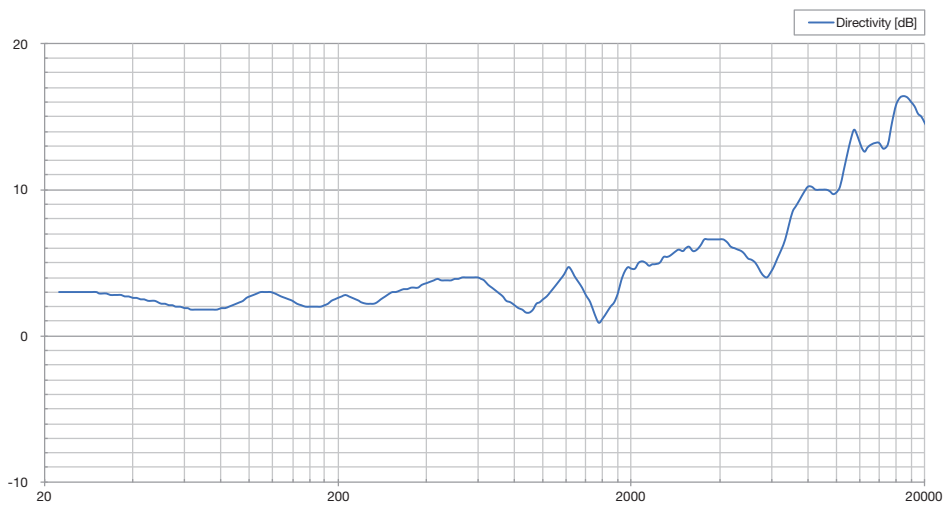

## Polar Plots

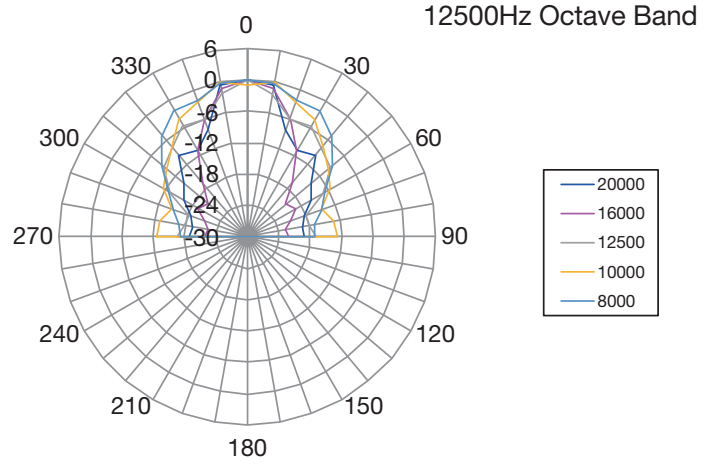
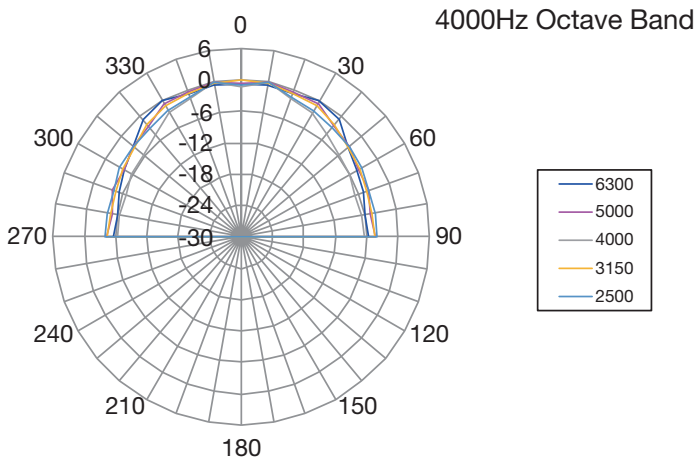
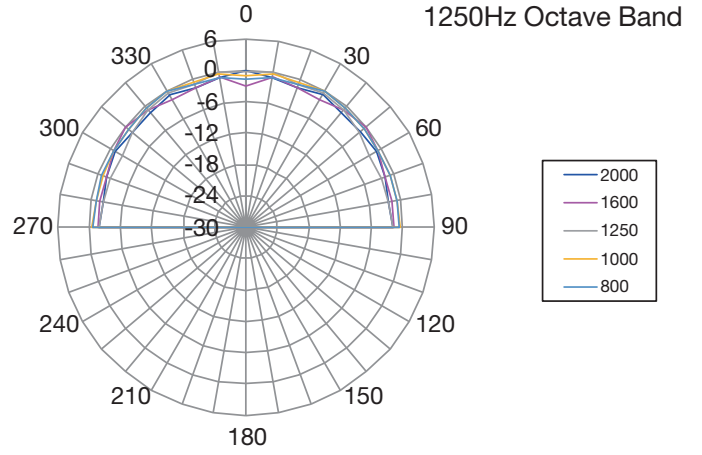
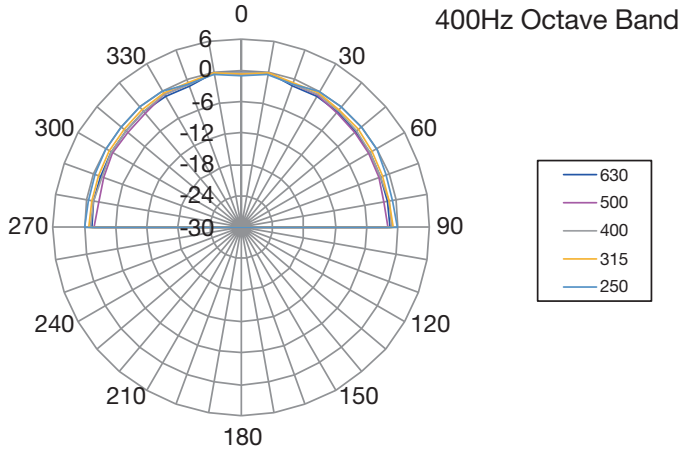

\*All information subject to change without notice.

\*All trademarks and registered trademarks are property of their respective owners.

Created in December, 2019